



Aakash

Medical | IIT-JEE | Foundations

(Divisions of Aakash Educational Services Pvt. Ltd.)

Regd. Office : Aakash Tower, 8, Pusa Road, New Delhi-110005 Ph.: 011-47623456

MOCK TEST for JEE (Advanced)-2018

Time : 3 Hrs.

Paper - I (Code-A)

MM : 183

INSTRUCTIONS FOR CANDIDATE

- Read each question carefully.
- It is mandatory to use blue/black ballpoint pen to darken the appropriate circle in the answer sheet.
- Mark should be dark and should completely fill the circle.
- Rough work must not be done on the answer sheet.
- Do not use white-fluid or any other rubbing material on answer sheet.
- Student cannot use log table and calculator or any other material in the examination hall.
- Before attempting the question paper, student should ensure that the test paper contains all pages and no page is missing.
- Before handing over the answer sheet to the invigilator, candidate should check that Roll No., Centre Code and Date of Birth have been filled and marked correctly.
- Immediately after the prescribed examination time is over, the answer sheet to be returned to the invigilator.
- Pattern of the questions are as under:**
 - The question paper consists of three parts (Physics, Chemistry and Mathematics). Each part has **three sections**.
 - Section-1:** This section contains 7 multiple choice questions which have one or more correct answer(s). Each question carries **+4 marks** for correct answer and **-2 mark** for wrong answer. **Partial +1 mark** is given for darkening a bubble corresponding to each correct option, provided **NO** incorrect option is darkened.
 - Section-2:** This section contains 5 questions. The answers to each of the questions is a single digit integer, ranging from 0 to 9 (both inclusive) without being given any option. Each question carries **+3 marks** for correct answer. There is no negative mark for wrong answer.
 - Section-3:** This section contains **SIX** questions of matching type. This section contains **TWO** tables (each having 3 columns and 4 rows). For each entry in Column I you will be awarded **+3 marks** if only the bubble(s) corresponding to all the correct match(es) is (are) darkened, and **zero mark** if none of the bubbles is darkened, minus one **(-1) mark** in all other cases.

PART - I : PHYSICS

SECTION - 1

One or More than One Option Correct Type

This section contains **SEVEN** questions. Each question has **FOUR** options [A], [B], [C] and [D]. **ONE OR MORE THAN ONE** of these four option(s) is(are) correct.

- A hydrogen-like atom (described by Bohr model) is observed to emit six wavelengths, originating from all possible transitions between a group of levels. These levels have energies between -30.60 eV and -4.896 eV. (including both these values). Which of the following statement(s) is(are) true? [Take $hc = 1240$ eV-nm, ground state energy of hydrogen atom = -13.6 eV]
 - Atomic number of the atom is 3
 - Energy level of energy state -30.60 eV is 3
 - Energy level of energy state -4.896 eV is 6
 - Smallest wavelength emitted in these transitions is 482 \AA
- A square ground of side $a = \frac{10}{\sqrt{2}}$ m has a circular running track of radius $\frac{a}{2}$ with its centre coinciding the centre of the ground. A man is running on the track with an angular velocity $\omega = 22$ rad/s while a car is moving on a road adjacent to ground as shown. The car moves in such a way that the car, the man and the centre of the ground always lie on the same straight line. A source of sound of frequency $n = 300$ Hz is being placed at the center of the ground. The speed of sound in air is 330 m/s. Which of the following statement(s) is(are) true regarding the sound received by the man in the car? [θ is measured between the line joining car and center with vertical OA]
 - The minimum frequency received by the man in the car is 250 Hz
 - The minimum frequency received by the man in the car is 200 Hz
 - At $\theta = 45^\circ$, minimum frequency is received by the man in the car
 - At $\theta = 30^\circ$, minimum frequency is received by the man in the car

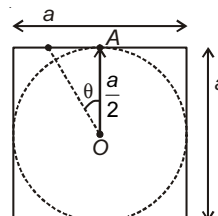

3. A large number of identical rods are arranged as shown. Each rod has length l , cross-sectional area A and thermal conductivity of material is k . Ends X and Y are maintained at temperatures θ_1 and θ_2 ($< \theta_1$) respectively. If lateral surface of each rod is thermally insulated, then which of the following statement(s) is(are) true at steady state?

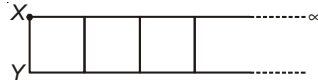

- (A) Equivalent thermal resistance between X and $Y = \frac{l(\sqrt{3}-1)}{kA}$
- (B) Equivalent thermal resistance between X and $Y = \frac{l(\sqrt{3}+1)}{kA}$
- (C) Rate of heat flow between X and $Y = \frac{kA(\theta_1 - \theta_2)}{l(\sqrt{3}+1)}$
- (D) Rate of heat flow between X and $Y = \frac{kA(\theta_1 - \theta_2)}{l(\sqrt{3}-1)}$
4. The image of an object, formed by a plano-convex lens at a distance of 8 m behind the lens, is real and is one-third the size of the object. The wavelength of light inside the lens is $\frac{2}{3}$ times the wavelength in free space. Which of the following statement(s) is(are) true?
- (A) The refractive index of the lens is 1.5
- (B) The distance of object from the lens is 12 m
- (C) The focal length of the lens is 6 m
- (D) The radius of curvature of the convex surface is 3 m
5. A flexible circular loop 10 cm in diameter lies in a magnetic field of 1.2 T, directed into the plane of paper as shown. The loop is pulled at the points indicated by the arrows, forming a loop of zero area in 0.2 s. If the resistance of external circuit $R = 10 \Omega$ and the resistance of the loop is negligible, then which of the following statement(s) is(are) correct?

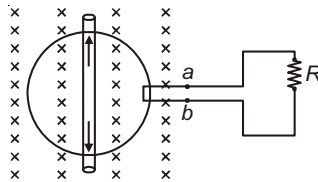

- (A) Average induced emf in the circuit is 0.047 volt
- (B) Direction of current in R is anticlockwise
- (C) Induced charge flowing through R during 0.2 s is equal to 9.42×10^{-4} C
- (D) Induced charge flowing through R during 0.2 s is equal to 4.7×10^{-3} C
6. A conductor (shown in the figure) carrying constant current I is kept in the x - y plane in a uniform magnetic field \vec{B} . If F is the magnitude of the total magnetic force acting on the conductor, then the correct statement(s) is(are)

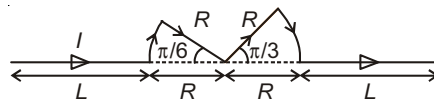

- (A) If \vec{B} is along \hat{z} , $F \propto (L + R)$
- (B) If \vec{B} is along \hat{x} , $F = 0$
- (C) If \vec{B} is along \hat{y} , $F \propto (L + R)$
- (D) If \vec{B} is along \hat{z} , $F = 0$
7. A container of fixed volume, has a mixture of one mole of oxygen and one mole of helium in equilibrium at temperature T . Assuming the gases are ideal, the correct statement(s) is(are)
- (A) The average energy per mole of the gas mixture is $2RT$
- (B) The ratio of speed of sound in the gas mixture to that in helium gas is $\frac{1}{\sqrt{5}}$
- (C) The ratio of rms speed of helium atoms to that of oxygen molecules is $\frac{1}{\sqrt{2}}$
- (D) The ratio of the rms speed of helium atoms to that of oxygen molecules is $2\sqrt{2}$

SECTION - 2

Integer Value Type

This section contains 5 questions. The answer to each of the questions is a **single-digit integer**, ranging from 0 to 9, (both inclusive). The answer will have to be appropriately bubbled in the ORS as per the instructions as follows. **Examples-** If the correct answer to question numbers X, Y and Z (say) are 6, 0 and 9 respectively, then mark 6, 0 and 9 in ORS respectively.

X	① ② ③ ④ ⑤ ● ⑦ ⑧ ⑨
Y	● ① ② ③ ④ ⑤ ⑥ ⑦ ⑧ ⑨
Z	① ② ③ ④ ⑤ ⑥ ⑦ ⑧ ●

8. Find the quantum number n corresponding to excited state of He^+ ion, if on de-excitation to the ground state, the ion emits two photons in succession with wavelengths 108.72 nm and 30.44 nm. The ionisation energy of H-atom is 13.6 eV. Take $hc = 1242 \text{ eV}\cdot\text{nm}$.

9.

	$A \xrightarrow{\lambda} B \xrightarrow{2\lambda} C$
No. of active nuclei at $t = 0$	$N_0 \quad 0 \quad 0$
No. of active nuclei at time t	$N_1 \quad N_2 \quad N_3$

The ratio of N_1 to N_2 when N_2 is maximum, is

10. Two spherical stars A and B emit black body radiations. The radius of A is 900 times that of B and A emits 10^4 times the power emitted from B. The ratio $\left(\frac{\lambda_A}{\lambda_B}\right)$ of their wavelengths λ_A and λ_B at which the peak occur in their respective radiation curves is

11. Consider two solid spheres A and B each of density 9 gm/cc and diameters 2 cm and 1 cm respectively. Sphere A is dropped into a liquid of density 1.8 gm/cc and viscosity $\eta = 3$ poiseuilles. Sphere B is dropped into a liquid of density 2.6 gm/cc and viscosity $\eta = 2$ poiseuilles. The ratio of terminal velocities of A and B is

12. Two capacitors $C_1 = 1 \mu\text{F}$ and $C_2 = 2 \mu\text{F}$ are arranged in given electrical circuit as shown across a battery of 10 volt. The circuit is switched on at time $t = 0$. The ratio of the maximum to the minimum current ($I_{\text{max}}/I_{\text{min}}$) drawn from the battery is

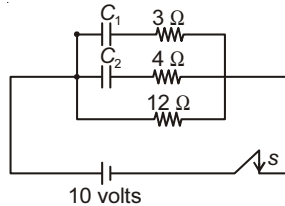

SECTION - 3

Matching Type

This section contains **SIX** questions of matching type. This section contains **TWO** tables (each having 3 columns and 4 rows). Based on each table, there are **THREE** questions. Each question has **FOUR** options [A], [B], [C] and [D]. **ONLY ONE** of these four options is correct. For each question, darken the bubble corresponding to the correct option in the ORS.

Answer Q.13, Q.14 and Q.15 by appropriately matching the information given in the three columns of the following table.

A uniform sphere of mass M and radius R is lying at rest on a horizontal surface. The coefficient of friction between the sphere and the surface is μ . A constant horizontal force F starts acting on the sphere at $t = 0$. The distance between the line of F and the horizontal line through centre is h . The values of F , h and μ are given in column I, II and III respectively.

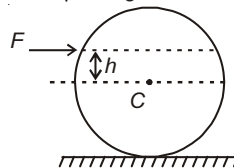

Column I	Column II	Column III
(I) $F = Mg$	(i) $h = 0.2 R$	(P) $\mu = 0$
(II) $F = 0.6 Mg$	(ii) $h = 0.4 R$	(Q) $\mu = \frac{9}{35}$
(III) $F = 0.4 Mg$	(iii) $h = 0.3 R$	(R) $\mu = \frac{1}{14}$
(IV) $F = 0.2 Mg$	(iv) $h = R$	(S) $\mu = \frac{3}{14}$

13. For which of the following combinations the sphere rolls without slipping without any frictional force acting on the sphere?
- (A) (I) (i) (P) (B) (II) (ii) (R)
 (C) (III) (iii) (Q) (D) (IV) (iv) (S)
14. For which of the following combinations the frictional force acting on the sphere equals limiting friction in the right direction?
- (A) (I) (i) (Q) (B) (I) (iv) (Q)
 (C) (II) (iv) (Q) (D) (II) (iv) (S)
15. For which of the following combinations the frictional force acting on the sphere is limiting and towards left ?
- (A) (I) (i) (Q) (B) (II) (ii) (R)
 (C) (III) (i) (Q) (D) (I) (iii) (R)

Answer Q.16, Q.17 and Q.18 by appropriately matching the information given in the three columns of the following table.

One mole of an ideal monatomic gas is undergoing a cyclic thermodynamic process in different ways as shown in the corresponding indicator diagram in column III of the matrix. Consider only the path from state 1 to state 2. W denotes the corresponding work done by the system. The equations and plots in the table have standard notations as used in thermodynamic processes.

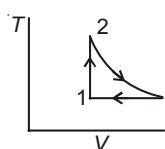
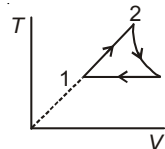
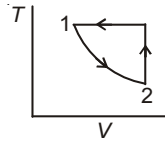
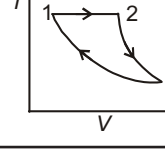
Column I	Column II	Column III
(I) $W_{1 \rightarrow 2} = RT \ln \frac{V_2}{V_1}$	(i) $PV^2 = \text{Constant}$	(P) 
(II) $W_{1 \rightarrow 2} = P_1 V_1 - P_2 V_2$	(ii) Isochoric	(Q) 
(III) $W_{1 \rightarrow 2} = P(V_2 - V_1)$	(iii) Isothermal	(R) 
(IV) $W_{1 \rightarrow 2} = 0$	(iv) Isobaric	(S) 

16. Which of the following options is the correct representation of the process in which $\Delta U = 0$?
- (A) (II) (i) (R) (B) (I) (ii) (Q)
 (C) (I) (iii) (S) (D) (III) (iii) (S)
17. Which one of the following options correctly represents a thermodynamic process for which molar specific heat is equal to $\frac{R}{2}$?
- (A) (I) (i) P (B) (II) (i) (R)
 (C) (III) (iii) (Q) (D) (IV) (iv) (S)
18. Which one of the following options is the correct combination ?
- (A) (III) (iv) (Q) (B) (IV) (iii) (P)
 (C) (I) (ii) (Q) (D) (II) (i) (S)

PART - II : CHEMISTRY

SECTION - 1

One or More than One Option Correct Type

This section contains **SEVEN** questions. Each question has **FOUR** options [A], [B], [C] and [D]. **ONE OR MORE THAN ONE** of these four option(s) is(are) correct.

19. A stationary Li^{+2} ion emits a photon corresponding to first line of Lyman series. Photon thus emitted hit on electron of H-atom in ground state. Assume one photon ejects one electron. Kinetic energy of emitted electron will be (E_1 for hydrogen = 2.18×10^{-18} J/atom)
- (A) 12.535×10^{-18} J (B) 14.715×10^{-18} J
 (C) 2.18×10^{-18} J (D) No electron is ejected

20. Which of the following is most basic in nature?

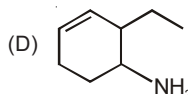
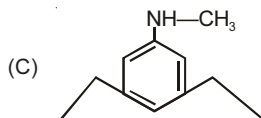
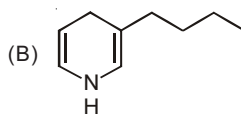
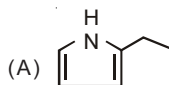

21. The sublimation energy of metal is 80 kJ/mole. Its first and second ionization energies are 300 and 700 kJ/mole respectively. The hydration energy of M^+ is -400 kJ/mole and M^{2+} is -1200 kJ/mole. Then, which of the following is applicable to stability of two ions in water?
- (A) M^+ and M^{2+} are equally stable in aqueous medium
 (B) M^{2+} is more stable than M^+ in aqueous medium
 (C) M^+ is more stable than M^{2+} in aqueous medium
 (D) Lesser is hydration energy released, more is stability

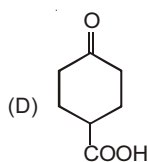
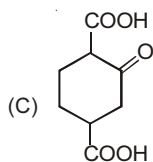
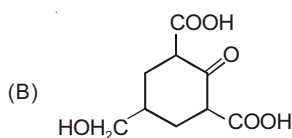
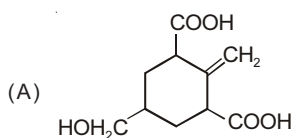
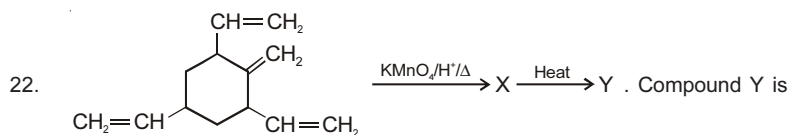

23. A 200 mL flask and a 150 mL flask are separated by a stopcock. At 300 K, the nitric oxide exerts pressure of 1.5 atm in larger flask and smaller one contains oxygen at 0.5 atm. At room temperature gases completely react according to the following reaction.

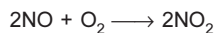

Dimer N_2O_4 solidify at 262 K. The gases are mixed by opening stopcock and after the end of reaction the flasks are cooled to 220 K. Find the pressure of the mixture after reaction at 220 K (neglect V.P. of solid) assume gases to behave ideally.

- (A) 4 atm (B) 0.214 atm
 (C) 0.31 atm (D) 0.15 atm

24. Which of the following will provide precipitate with H_2S in the presence of acid?
- (A) Mn^{2+} (B) Ni^{2+}
 (C) Co^{2+} (D) Cd^{2+}
25. In a lead storage battery, which option is incorrect for the discharging of battery?
- (A) The reaction at anode is $\text{Pb} \rightarrow \text{Pb}^{2+} + 2\text{e}^-$
 (B) The reaction taking place at cathode is $2\text{PbSO}_4 + 2\text{H}_2\text{O} \rightarrow \text{Pb} + \text{PbO}_2 + 2\text{H}_2\text{SO}_4$
 (C) The overall reaction is $\text{Pb} + \text{PbO}_2 + 4\text{H}^+ + 2\text{SO}_4^{2-} \rightarrow 2\text{PbSO}_4 + 2\text{H}_2\text{O}$
 (D) $\text{PbO}_2 + 4\text{H}^+ + 2\text{e}^- \rightarrow \text{Pb}^{2+} + 2\text{H}_2\text{O}$ is the reaction taking place at cathode

SECTION - 2

Integer Value Type

This section contains 5 questions. The answer to each of the questions is a **single-digit integer**, ranging from 0 to 9, (both inclusive). The answer will have to be appropriately bubbled in the ORS as per the instructions as follows. **Examples-** If the correct answer to question numbers X, Y and Z (say) are 6, 0 and 9 respectively, then mark 6, 0 and 9 in ORS respectively.

X	① ② ③ ④ ⑤ ● ⑦ ⑧ ⑨
Y	● ① ② ③ ④ ⑤ ⑥ ⑦ ⑧ ⑨
Z	① ② ③ ④ ⑤ ⑥ ⑦ ⑧ ●

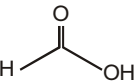
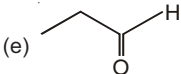
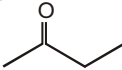
26. How many compounds can give positive test with ammoniacal silver nitrate?
- (a) Glucose (b) Sucrose (c) Fructose
- (d)  (e)  (f) 
27. Identify number of complexes/compounds, which are expected to be coloured.
- (a) $\text{K}_3[\text{VF}_6]$ (b) $[\text{Cu}(\text{NH}_2\text{CH}_3)]^+\text{BF}_4^-$ (c) KMnO_4
 (d) $\text{Ti}(\text{NO}_3)_4$ (e) $[\text{Cr}(\text{NH}_3)_6]\text{Cl}_3$ (f) PbCrO_4
 (g) CrO_2Cl_2
28. How many statements are correct out of following for a given amount of a gas at constant temperature?
- (i) For ideal gas $\frac{d(\text{PV})}{dP} \neq 0$
 (ii) For ideal gas $\frac{d(\text{PV})}{dP} = 0$
 (iii) For real gas $\frac{d(\text{PV})}{dP}$ can be less than zero
 (iv) For real gas $\frac{d(\text{PV})}{dP}$ can be equal to zero when $z < 1$
 (v) For real gas $\frac{d(\text{PV})}{dP}$ can be more than zero when $z < 1$
 (vi) For real gas $\frac{d(\text{PV})}{dP} > 0$ when $z > 1$
29. A given sample of Ferrous oxalate weighing 14.4 gm will require what volume in litres of 0.02 M KMnO_4 in acidic medium to get oxidised completely? ($M_{\text{FeC}_2\text{O}_4} = 144$ g/mole)
30. How many compounds/salts give basic solution when 0.1 mole of each is dissolved in 1000 ml of water?
- (a) NaCl (b) NaClO_4 (c) Na_2O (d) KNO_2
 (e) NaI (f) Sodium propanoate (g) NH_4Cl

SECTION - 3

Matching Type

This section contains **SIX** questions of matching type. This section contains **TWO** tables (each having 3 columns and 4 rows). Based on each table, there are **THREE** questions. Each question has **FOUR** options [A], [B], [C] and [D]. **ONLY ONE** of these four options is correct. For each question, darken the bubble corresponding to the correct option in the ORS.

Answer Q.31, Q.32 and Q.33 by appropriately matching the information given in the three columns of the following table.

Column I (Compound)	Column II (Preparation method)	Column III (Properties or use)
(I) Washing soda	(i) Heating of litharge (PbO) in air	(P) More than one type of oxidation
(II) Lime stone	(ii) Neutralization product of slaked lime and CO ₂	(Q) Used for preparation of burnt lime
(III) Borazine	(iii) Diborane and ammonia	(R) Used for manufacture of glass
(IV) Sindur or minium	(iv) Solvay process	(S) Pure sample is explosive

31. Identify the correct match for Column I, II and III.
- (A) (I) (iii) (S) (B) (II) (i) (Q)
 (C) (III) (iii) (S) (D) (IV) (ii) (R)
32. Crystalline compound X given in Column-I shows efflorescence while pure compound is hygroscopic. It used as water softener. When CO₂ is passed through its aqueous colourless solution it turns milky. Identify the correct match for compound X.
- (A) (IV) (ii) (Q) (B) (II) (ii) (S)
 (C) (I) (iv) (R) (D) Both (A) & (B)
33. Which is correct match for red coloured compound Y given in Column I?
- (A) (II) (ii) (Q) (B) (I) (iv) (R)
 (C) (IV) (ii) (Q) (D) (IV) (i) (P)

Answer Q.34, Q.35 and Q.36 by appropriately matching the information given in the three columns of the following table.

Column I	Column II	Column III
(I) $\begin{array}{c} \text{CH}_3 \\ \diagdown \\ \text{C}=\text{C} \\ \diagup \\ \text{H} \end{array} + \text{H}_2\text{O} \xrightarrow{\text{H}^+}$	(i) $\Delta G = -ve$ at lower temperature	(P) Markovnikov's addition
(II) $\text{CO} + \frac{1}{2}\text{O}_2 \rightarrow \text{CO}_2$	(ii) $\Delta G = +ve$ at higher temperature	(Q) High pressure favour the forward reaction
(III) $\text{PCl}_5(\text{g}) \rightleftharpoons \text{PCl}_3(\text{g}) + \text{Cl}_2(\text{g})$	(iii) $\Delta G = -ve$ at higher temperature	(R) Low pressure favour the forward reaction
(IV) $\text{N}_2(\text{g}) + 3\text{H}_2(\text{g}) \rightleftharpoons 2\text{NH}_3(\text{g})$	(iv) $\Delta G = +ve$ at lower temperature	(S) High temperature is favourable for forward reaction

34. Identify the correct match for the organic addition reaction given in above matrix.
- (A) (I) (iii) (Q) (B) (IV) (iv) (R)
 (C) (I) (i) (P) (D) (I) (i) (S)
35. Identify the correct match of Column I, II and III for an entropy driven reaction.
- (A) (I) (iii) (Q) (B) (IV) (ii) (Q)
 (C) (III) (iii) (R) (D) (II) (ii) (P)
36. Identify the incorrect statement about the ΔH , ΔS of reactions given in Column I.
- (A) For (I), $\Delta H = -ve$, $\Delta S = -ve$ (B) For (II), $\Delta H = -ve$, $\Delta S = +ve$
 (C) For (III), $\Delta H = +ve$, $\Delta S = +ve$ (D) For (IV), $\Delta H = -ve$, $\Delta S = -ve$

PART - III : MATHEMATICS

SECTION - 1

One or More than One Option Correct Type

This section contains **SEVEN** questions. Each question has **FOUR** options [A], [B], [C] and [D]. **ONE OR MORE THAN ONE** of these four option(s) is(are) correct.

37. The locus of the middle points of the chords of the hyperbola $\frac{x^2}{16} - \frac{y^2}{9} = 1$, which pass through a fixed point $(4, 2)$, is a curve C . Then
- (A) Centre of the curve C is $(2, 1)$ (B) Foci of the curve C are $\left(\frac{43}{9}, 1\right)$ and $\left(-\frac{7}{9}, 1\right)$
- (C) Eccentricity of the curve C is $\frac{5}{4}$ (D) Eccentricity of the curve C is $\frac{4}{3}$
38. Let $A = [a_{ij}]$ be 3×3 matrix and let $B = [b_{ij}]$ where $b_{ij} = 5^{i-j} a_{ij} \forall i, j \in \{1, 2, 3\}$. If $|A| = 600$ and $|B| = \lambda$, then
- (A) Number of odd divisors of λ is 6
 (B) Number of divisors of λ which are perfect square is 4
 (C) Number of divisors of λ which are even is 20
 (D) Number of divisors of λ which are divisible by 24 is 3
39. A ray of light is coming from the point $P(3, 5, 7)$ and it get reflected by a plane mirror $2x + y - z = 10$ and reflected ray passes through the point $R(1, 4, 9)$. Then
- (A) Equation of the reflected ray is $\frac{x-1}{3} = \frac{y-4}{6} = \frac{z-9}{-4}$
 (B) Equation of the reflected ray is $\frac{x-1}{6} = \frac{y-4}{3} = \frac{z-9}{-4}$
 (C) Point of incident of incident ray on the plane mirror is $\left(\frac{97}{19}, \frac{115}{19}, \frac{119}{19}\right)$
 (D) Point of incident of incident ray on the plane mirror is $\left(\frac{97}{17}, \frac{95}{17}, \frac{105}{17}\right)$
40. The tangent at a point $P(x, y)$ of a curve $y = f(x)$ meets the axis of y at point N , a perpendicular drawn from P to x -axis meets the axis of x at point M ; O is the origin and curve $y = f(x)$ passes through the point $(1, 1)$. If the area of the triangle MON is 2 sq. units, then
- (A) Eccentricity of the curve $y = f(x)$ is less than 1 (B) Eccentricity of the curve $y = f(x)$ is greater than 1
 (C) $y = f(x)$ passes through the point $(2, 5)$ (D) $y = f(x)$ passes through the point $(-1, -1)$
41. A function $f(x)$ defined on $[-1, 4]$ as follows
- $$f(x) = \begin{cases} \max\{-x, x^2\}; & -1 \leq x < 0 \\ \min\{x^2, (x-2)^2\}; & 0 \leq x \leq 2 \\ \max\{4-x, 6x-x^2-8\}; & 2 < x \leq 4 \end{cases}$$
- Then
- (A) $f(x)$ is discontinuous at exactly one point in $[-1, 4]$ (B) $f(x)$ is non-differentiable at four points in $(-1, 4)$
 (C) Number of local maxima of $f(x)$ are two in $(-1, 4)$ (D) Number of local minima of $f(x)$ are two in $(-1, 4)$

42. If $z^3 + (3+2i)z + (-1+i\lambda) = 0$; where $i = \sqrt{-1}$, has one real root, then the value of λ does not belong to the interval (λ is a real number)
- (A) (0, 1)
 (B) (-2, -1)
 (C) (2, 3)
 (D) (-5, -1)
43. If $E_1, E_2, E_3, \dots, E_{1008}$ be 1008 independent events such that $P(E_i) = \frac{i}{2i+1}$; ($i = 1, 2, \dots, 1008$) and probability that none of the events occurs be $\frac{2^b(b!)(c!)}{(d!)}$; (where $b, c, d \in N$ and $b < c < d$), then
- (A) $b + c = d$
 (B) $2b + 1 = d$
 (C) $2c + 1 = d$
 (D) $2c - 1 = d$

SECTION - 2

Integer Value Type

This section contains 5 questions. The answer to each of the questions is a **single-digit integer**, ranging from 0 to 9, (both inclusive). The answer will have to be appropriately bubbled in the ORS as per the instructions as follows. **Examples-** If the correct answer to question numbers X, Y and Z (say) are 6, 0 and 9 respectively, then mark 6, 0 and 9 in ORS respectively.

X	① ② ③ ④ ⑤ ● ⑦ ⑧ ⑨
Y	● ① ② ③ ④ ⑤ ⑥ ⑦ ⑧ ⑨
Z	① ② ③ ④ ⑤ ⑥ ⑦ ⑧ ●

44. $\lim_{x \rightarrow \infty} \left(\frac{x^3 + 4x^2 + 3x + 5}{x^2 + 2x + 3} + lx + m \right) = 10$, where $l, m \in R$, then the value of $l^2 + m$ is
45. Let $f(x)$ be a differentiable function such that $f(x) = 1 + \frac{x^3}{3} + \int_0^x e^{-t} f(x-t) dt$, if $\int_0^1 f(x) dx = p$, then the value of $5p$ is
46. Let $S = (a_6 - a_5) \left(\frac{1}{\sqrt{a_1} + \sqrt{a_2}} + \frac{1}{\sqrt{a_2} + \sqrt{a_3}} + \dots + \frac{1}{\sqrt{a_{n-1}} + \sqrt{a_n}} \right)$ where a_1, a_2, \dots, a_n are terms of an A.P. and $a_i > 0 \forall i$. If $a_1 = 100$ and $a_n = 900$, then the value of $S - 20$ is
47. If vectors $\lambda x^2 \hat{i} + \hat{j} + 5\hat{k}$ and $\hat{i} + \lambda x \hat{j} + 5\hat{k}$ make an acute angle with each other for all real x , then the number of value(s) of λ which are perfect cube, is
48. If x and y are satisfying $x^2 + y^2 - 6x - 8y = 0$ and $a = \max\{x + y\}$ and $b = \min\{x - y\}$, then the value of $a + b$ is

SECTION - 3

Matching Type

This section contains **SIX** questions of matching type. This section contains **TWO** tables (each having 3 columns and 4 rows). Based on each table, there are **THREE** questions. Each question has **FOUR** options [A], [B], [C] and [D]. **ONLY ONE** of these four options is correct. For each question, darken the bubble corresponding to the correct option in the ORS.

Answer Q.49, Q.50 and Q.51 by appropriately matching the information given in the three columns of the following table.

Column I : A trigonometrical expression is given.

Column II : Sum of maximum and minimum values of the expression is given.

Column III : If $x \in (0, 2\pi)$, then the number of roots of $f(x) = 1$ is given.

Column I	Column II	Column III
(I) $f(x) = \frac{1 - \tan^2\left(\frac{\pi}{4} - x\right)}{1 + \tan^2\left(\frac{\pi}{4} - x\right)}$	(i) 0	(P) 1
(II) $f(x) = \log_3\left(\frac{5 \sin x - 12 \cos x + 26}{13}\right)$	(ii) 1	(Q) 2
(III) $f(x) = -2 \sin^2 x + \cos x + 3$	(iii) 5	(R) 3
(IV) $f(x) = 4 \sin^2 x + 4 \sin x \cos x + \cos^2 x$	(iv) $\frac{39}{8}$	(S) 4

49. Which of the following is the only correct combination?
 (A) (I) (ii) (S) (B) (II) (ii) (P)
 (C) (III) (i) (Q) (D) (IV) (iii) (P)
50. Which of the following is the only incorrect combination?
 (A) (I) (i) (Q) (B) (III) (iv) (S)
 (C) (IV) (iii) (R) (D) (II) (i) (P)
51. Which of the following is the only correct combination?
 (A) (I) (i) (P) (B) (II) (iii) (S)
 (C) (III) (iv) (S) (D) (IV) (ii) (Q)

Answer Q.52, Q.53 and Q.54 by appropriately matching the information given in the three columns of the following table. Column I, II and III contains conics, equation of tangents to conics and equation of normals, respectively.

Column I	Column II	Column III
(I) $x^2 + y^2 + 4y - 1 = 0$	(i) $2x - y - 1 = 0$	(P) $x + 2y - 8 = 0$
(II) $x^2 + y^2 - 4x - 4y + 7 = 0$	(ii) $x - 2y - 9 = 0$	(Q) $4x - 4y - 27 = 0$
(III) $3x^2 - y^2 = 3$	(iii) $x - 3 = 0$	(R) $x - y - 2 = 0$
(IV) $y^2 - 16x - 4y - 48 = 0$	(iv) $4x - y + 16 = 0$	(S) $x - y = 0$

52. Which of the following is the only correct combination?
 (A) (I) (ii) (R) (B) (II) (i) (S)
 (C) (III) (i) (Q) (D) (IV) (iii) (Q)
53. Which of the following is the only incorrect combination?
 (A) (II) (iii) (S) (B) (III) (i) (P)
 (C) (IV) (iii) (Q) (D) (IV) (iv) (Q)
54. Which of the following is the only correct combination?
 (A) (I) (iii) (R) (B) (II) (iv) (S)
 (C) (III) (i) (P) (D) (IV) (ii) (P)



QR Code



To get quick video Solution of Mock Test Paper (Paper-1), follow the steps below:

1. Scan QR Code
2. Don't have QR reader? Download Aakash i-Tutor app from Google play or App Store and scan the QR Code.



Aakash

Medical | IIT-JEE | Foundations

(Divisions of Aakash Educational Services Pvt. Ltd.)

Regd. Office : Aakash Tower, 8, Pusa Road, New Delhi-110005 Ph.: 011-47623456

MOCK TEST for JEE (Advanced)-2018

Time : 3 Hrs.

Paper - II (Code-B)

MM : 183

INSTRUCTIONS FOR CANDIDATE

1. Read each question carefully.
 2. It is mandatory to use blue/black ballpoint pen to darken the appropriate circle in the answer sheet.
 3. Mark should be dark and should completely fill the circle.
 4. Rough work must not be done on the answer sheet.
 5. Do not use white-fluid or any other rubbing material on answer sheet.
 6. Student cannot use log table and calculator or any other material in the examination hall.
 7. Before attempting the question paper, student should ensure that the test paper contains all pages and no page is missing.
 8. Before handing over the answer sheet to the invigilator, candidate should check that Roll No., Centre Code and Date of Birth have been filled and marked correctly.
 9. Immediately after the prescribed examination time is over, the answer sheet to be returned to the invigilator.
- 10. Pattern of the questions are as under:**
- (i) The question paper consists of three parts (Physics, Chemistry and Mathematics). Each part has **three sections**.
 - (ii) **Section-1:** This section contains 7 multiple choice questions which have only one correct answer. Each question carries **+3 marks** for correct answer and **-1 mark** for wrong answer.
 - (iii) **Section-2:** This section contains 7 multiple choice questions which have one or more answers are correct. Each question carries **+4 marks** each for correct answer and **-2 mark** for wrong answer. Partial **+1 mark** is given for darkening a bubble corresponding to each correct option, provided NO incorrect option is darkened.
 - (iv) **Section-3:** This section contains 2 paragraphs. Based upon each paragraph, 2 multiple choice questions have to be answered. Each question has only one correct answer and carries **+3 marks** for correct answer. There is no negative marking.

PART - I : PHYSICS

SECTION - 1

Only One Option Correct Type

This section contains 7 multiple choice questions. Each question has 4 choices (A), (B), (C) and (D) out of which **ONLY ONE** is correct.

1. A rod of length l and cross section area A has a variable thermal conductivity given by $k = \alpha T$, where α is a positive constant and T is temperature in kelvin. Two ends of the rod are maintained at temperature T_1 and T_2 ($T_1 > T_2$). Heat current flowing through the rod will be
 - (A) $\frac{A\alpha(T_1^2 - T_2^2)}{l}$
 - (B) $\frac{A\alpha(T_1^2 + T_2^2)}{l}$
 - (C) $\frac{A\alpha(T_1^2 + T_2^2)}{3l}$
 - (D) $\frac{A\alpha(T_1^2 - T_2^2)}{2l}$
2. The surface of lithium is irradiated with electromagnetic radiation whose magnetic component varies with time as $B = \alpha(1 + \sin \omega t) \sin \omega_0 t$ where α is a constant and $\omega = 12\pi \times 10^{14} \text{ s}^{-1}$ and $\omega_0 = 8\pi \times 10^{14} \text{ s}^{-1}$. Then the maximum KE of photoelectron ejected is (Given work function of lithium $\phi_{\text{Li}} = 2.39 \text{ eV}$)
 - (A) 1.75 eV
 - (B) 3.5 eV
 - (C) 7 eV
 - (D) 5.25 eV

3. The diameter of a cylinder is measured using a vernier calliper with no zero error. It is found that the zero of the vernier scale lies between 5.10 cm and 5.15 cm of the main scale. The vernier scale has 50 divisions equivalent to 2.45 cm. The 24th division of the vernier scale exactly coincides with one of the main scale divisions. The diameter of the cylinder is
- (A) 5.112 cm (B) 5.124 cm
 (C) 5.136 cm (D) 5.148 cm
4. In an aluminium (Al) bar of circular cross-section, a circular hole is drilled and is filled with iron (Fe) as shown in the figure.

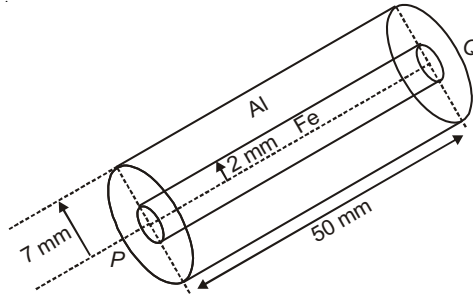

The electrical resistivities of Al and Fe are $2.7\pi \times 10^{-8} \Omega\text{m}$ and $1.0\pi \times 10^{-7} \Omega\text{m}$ respectively. The electrical resistance between the two faces P and Q of composite bar is

- (A) $\frac{2475}{64} \mu\Omega$ (B) $\frac{1875}{64} \mu\Omega$
 (C) $\frac{1875}{49} \mu\Omega$ (D) $\frac{2475}{132} \mu\Omega$
5. The figures below depict two situations in which two infinitely long static line charges of constant negative line charge density $-\lambda$ are kept parallel to each other. In their resulting electric field, point charges q and $-q$ are kept in equilibrium between them. The point charges are confined to move in the x direction only. If they are given a small displacement about their equilibrium positions, then the correct statement(s) is(are)



- (A) Both charges execute simple harmonic motion
 (B) Both charges will continue moving in the direction of their displacement
 (C) Charge $+q$ executes simple harmonic motion while charge $-q$ continues moving in the direction of its displacement
 (D) Charge $-q$ executes simple harmonic motion while charge $+q$ continues moving in the direction of its displacement
6. An interference is observed due to two coherent sources S_1 placed at origin and S_2 placed at $(0, 2\lambda, 0)$. Here λ is the wavelength of source. Then x coordinates on the positive x-axis (excluding $x = 0$ and $x = \infty$) where maximum intensity is observed is
- (A) 1.5λ (B) 3λ
 (C) 4.5λ (D) 6λ
7. A uniform ladder of length 5 m is placed against the wall as shown. If coefficient of friction μ is the same for both the walls, then the minimum value of μ for it not to slip, is

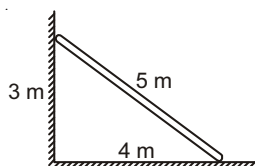

- (A) $\mu = \frac{1}{2}$ (B) $\mu = \frac{1}{4}$
 (C) $\mu = \frac{1}{3}$ (D) $\mu = \frac{1}{5}$

SECTION - 2

One or More Options Correct Type

This section contains 7 multiple choice questions. Each question has 4 choices (A), (B), (C) and (D) out of which **ONE OR MORE** is/are correct.

8. Suppose the potential energy between electron and proton at a distance r is given by $-\frac{ke^2}{4r^4}$ where $k = \frac{1}{4\pi\epsilon_0}$. Then according to Bohr's theory for this hypothetical atom, which of the following statement(s) is/are true for n^{th} state of electron?
- (A) The radius of orbit for revolving electron is given by $r = \frac{e}{nh} \sqrt{\frac{\pi m}{\epsilon_0}}$
- (B) The kinetic energy of electron is given by $\text{KE} = \frac{n^4 h^4 \epsilon_0}{8\pi^3 m^2 e^2}$
- (C) The potential energy of electron is given by $\text{PE} = \frac{n^4 h^4 \epsilon_0}{16\pi^3 m^2 e^2}$
- (D) The total energy of electron is $\text{TE} = n^4 h^4 \left(\frac{\pi \epsilon_0}{m^2 e^2} \right)$
9. A certain radioactive nuclide is being manufactured in a cyclotron at a constant rate R . It is also decaying with disintegration constant λ . Assume that the production process has been going on for a time that is much longer than the half life of the radioactive nuclide. Which of the following statement(s) is/are correct?
- (A) The number of radioactive nuclei present after such time remains constant and is given by $N = \frac{R}{\lambda}$
- (B) The number of radioactive nuclei present after such time (t) is given by $N = N_0 e^{-\lambda t}$, where $N_0 =$ Number of radioactive nuclide present initially
- (C) The number of radioactive nuclei present after such time is independent of radioactive nuclei present initially
- (D) The number of radioactive nuclei present after such time is dependent of radioactive nuclei present initially
10. A small body P (of mass m) is fixed to the inside of a rigid thin hollow cylinder of radius R and mass equal to that of the body P . The cylinder rolls without slipping over the horizontal plane. When the body P gets into the lower position, the centre of cylinder moves with velocity u . Which of the following statement(s) is/are correct?

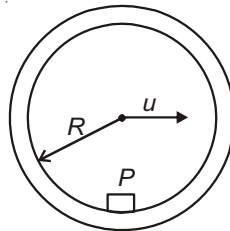

- (A) The velocity of center of cylinder when body P is at the highest point should be less than or equal to $\sqrt{2gR}$ for the cylinder to move without bouncing
- (B) The velocity of center of cylinder when body P is at the lowest point should be less than or equal to $\sqrt{8gR}$ for the cylinder to move without bouncing
- (C) It is not possible for cylinder to move without bouncing
- (D) The velocity of center of cylinder when body P is at the highest point should be greater than or equal to $\sqrt{4gR}$ for the cylinder to move without bouncing
11. A partition divides a container having insulated walls into two compartments I and II. The same gas fills the two compartments whose initial parameters are given. The partition is a conducting wall which can move freely without friction. Which of the following statement(s) is/are correct with reference to the final equilibrium position?

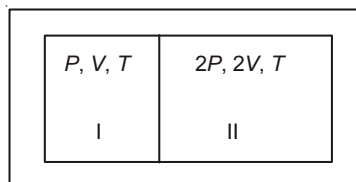

- (A) Final pressure in the two compartments are equal
- (B) Final volume of compartment I is $\frac{3V}{5}$
- (C) Final volume of compartment II is $\frac{12V}{5}$
- (D) Final temperature in the two compartments are equal

12. During an experiment an ideal gas is found to obey a condition $\frac{P^2}{\rho} = \text{constant}$ ($\rho = \text{density of gas}$). The gas initially at temperature T , pressure P and density ρ . The gas expands such that density changes to $\frac{\rho}{2}$. Which of the following statement(s) is/are correct?
- (A) The pressure of gas changes to $\sqrt{2}P$
 (B) The temperature of gas changes to $\sqrt{2}T$
 (C) The graph of the above process on the P - T diagram is parabola
 (D) The graph of the above process on the P - T diagram is rectangular hyperbola
13. An equiconvex lens is placed on a plane mirror. An object coincides with its image when it is at height of 24 cm from the lens. The gap between the lens ($\mu_g = 1.5$) and mirror is filled with water ($\mu_w = \frac{4}{3}$). Select the correct option(s).
- (A) The focal length of equiconvex lens is 30 cm
 (B) The equivalent focal length of combination of glass lens, water lens and plane mirror is equal to -18 cm
 (C) The equivalent focal length of lens-mirror combination without water is 10 cm
 (D) The distance by which the object must be shifted after filling water so that it again coincides with its image is 12 cm, upward
14. A block is executing SHM on a horizontal smooth surface having angular frequency (ω) and amplitude (A). When the block is at $x = \frac{A}{2}$ and moving away from mean position, it receives an impulse in the direction of its velocity by which its kinetic energy becomes 4 times. Which of the following statement(s) is/are correct?

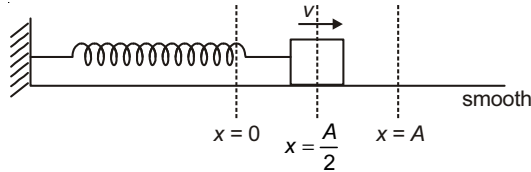

- (A) Time period of SHM is independent of impulse
 (B) The amplitude of SHM after impulse is equal to $\frac{\sqrt{13} A}{2}$
 (C) Minimum time taken by the block to cross the same position is equal to $\left(\frac{2 \cos^{-1} \frac{1}{\sqrt{13}}}{\omega} \right)$
 (D) Minimum time taken by the block to cross the same position is equal to $\left(\frac{\cos^{-1} \frac{1}{\sqrt{13}}}{\omega} \right)$

SECTION - 3

Paragraph Type

This section contains 2 paragraphs. Based on each paragraph, there are 2 questions. Each question has 4 choices (A), (B), (C) and (D) out of which **ONLY ONE** is correct.

Paragraph - 1 (Q. Nos. 15 & 16)

A uniform rod is hanging from the ceiling by the two threads as shown.

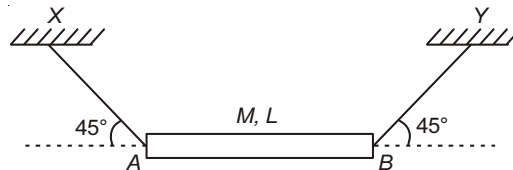

Now the string at B breaks.

15. The horizontal acceleration of centre of mass a_x , vertical acceleration of centre of mass a_y and angular acceleration of rod about centre of mass α are related as
- (A) $(a_x - a_y) + \alpha l = 0$ (B) $2a_x - a_y + \alpha l = 0$
 (C) $2(a_x - a_y) + \alpha l = 0$ (D) $a_x + a_y + 2\alpha l = 0$

16. The tension in the string XA immediately after string BY breaks is

- (A) $\frac{2mg}{5}$ (B) $\frac{mg}{5}$
 (C) $\frac{\sqrt{3}}{2}mg$ (D) $\frac{mg}{\sqrt{2}}$

Paragraph - 2 (Q. Nos. 17 & 18)

Two conducting spheres of radii r_1 and r_2 having charge Q_1 and Q_2 are placed at a large distance being connected by a conducting wire of resistance R .

17. The variation of charge flow q , as function of time t is (where $k = \frac{1}{4\pi\epsilon_0}$)

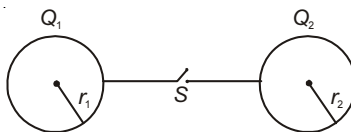

- (A) $q = \frac{Q_1 - Q_2}{\frac{1}{r_1} - \frac{1}{r_2}} \left(1 - e^{-\frac{kt\left(\frac{1}{r_1} + \frac{1}{r_2}\right)}{R}} \right)$ (B) $q = \frac{Q_1 + Q_2}{\frac{1}{r_1} + \frac{1}{r_2}} \left(1 - e^{-\frac{kt\left(\frac{1}{r_1} - \frac{1}{r_2}\right)}{R}} \right)$
 (C) $q = \frac{Q_1 - Q_2}{\frac{1}{r_1} + \frac{1}{r_2}} \left(1 - e^{-\frac{kt\left(\frac{1}{r_1} + \frac{1}{r_2}\right)}{R}} \right)$ (D) $q = \frac{Q_1 - Q_2}{\frac{1}{r_1} + \frac{1}{r_2}} \left(1 - e^{-\frac{kt\left(\frac{1}{r_1} - \frac{1}{r_2}\right)}{R}} \right)$

18. The heat dissipated H , in the circuit is given by

- (A) $H = \frac{r_1 r_2}{8\pi\epsilon_0(r_1 + r_2)} \left(\frac{Q_1}{r_1} - \frac{Q_2}{r_2} \right)^2$ (B) $H = \frac{r_1 r_2}{8\pi\epsilon_0(r_1 + r_2)} \left(\frac{Q_1}{r_1} + \frac{Q_2}{r_2} \right)^2$
 (C) $H = \frac{r_1 r_2}{\pi\epsilon_0(r_1 + r_2)} \left(\frac{Q_1}{r_1} - \frac{Q_2}{r_2} \right)^2$ (D) $H = \frac{r_1 r_2}{\pi\epsilon_0(r_1 + r_2)} \left(\frac{Q_1}{r_1} + \frac{Q_2}{r_2} \right)^2$

PART - II : CHEMISTRY

SECTION - 1

Only One Option Correct Type

This section contains 7 multiple choice questions. Each question has 4 choices (A), (B), (C) and (D) out of which **ONLY ONE** is correct.

19. A solid consisting of only X atoms has a close packing structure with X-X distance of 160 pm. Assuming it to be a closed packed structure of hard sphere with radius equal to half of the X-X bond length, the number of atoms in 1 cm^3 would be

- (A) 6.023×10^{27} (B) 3.45×10^{23}
 (C) 6.02×10^{21} (D) 3.8×10^{21}

20. Structure of $\text{Sb}(\text{Ph})_5$ and $\text{P}(\text{Ph})_5$ respectively is

- (A) Trigonal bipyramidal, square pyramidal (B) Square pyramidal, trigonal bipyramidal
 (C) Trigonal bipyramidal, trigonal bipyramidal (D) Square pyramidal, square pyramidal

21. At a given temperature consider

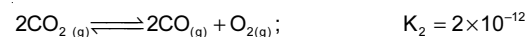
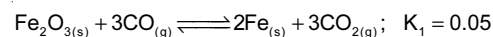

The equilibrium constant for the reaction

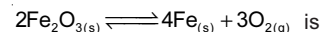

- (A) 1×10^{-13} (B) 2×10^{-38}
 (C) 4×10^{-15} (D) 2×10^{-24}

22. In a certain polluted area of Delhi in month of December atmosphere contain O_3 at a steady concentration of 4.0×10^{-8} mol/L, the hourly production of O_3 by all sources was estimated as 8.2×10^{-15} mol/L. The rate constant for the destruction reaction of ozone.
- $$2O_3 \rightarrow 3O_2$$
- (A) 1.4×10^{-3} L mol⁻¹s⁻¹ (B) 14.0×10^{-3} L mol⁻¹s⁻¹
 (C) 140×10^{-3} L mol⁻¹s⁻¹ (D) 0.14×10^{-3} L mol⁻¹s⁻¹
23. Following given Diels-Alder adduct can be obtained heating the appropriate diene and dienophile

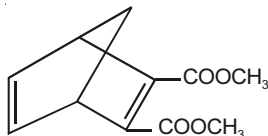

- The adduct shown above can be obtain from
- (A) Cyclopenta-1, 3-diene and dimethyl maleate (B) Cyclopenta-1, 3-diene and dimethyl fumarate
 (C) Cyclohexa-1, 2 diene and dimethyl maleate (D) Cyclopenta-1,3-diene and dimethyl acetylene dicarboxylate
24. The equilibrium constants K_{p1} and K_{p2} for reaction $X \rightleftharpoons 2Y$ and $Z \rightleftharpoons P+Q$ respectively are in the ratio of 1 : 9. If the degree of dissociation of X and Z be equal then ratio of total pressure at these equilibria is
- (A) 1 : 9 (B) 1 : 36
 (C) 1 : 1 (D) 1 : 3
25. The reactivity order of substituted phenols towards $R-\overset{\overset{O}{||}}{C}-Cl$ for
- (i) Electrophilic substitution reaction
 (ii) Phenyl ester formation

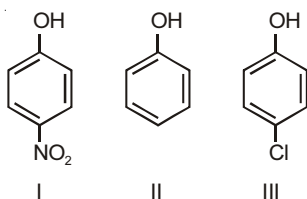

- (A) I > II > III for (ii) (B) I > III > II for (ii)
 (C) II > III > I for (i) (D) II > I > III for (i)

SECTION - 2

One or More Options Correct Type

This section contains 7 multiple choice questions. Each question has 4 choices (A), (B), (C) and (D) out of which **ONE OR MORE** is/are correct.

26. Consider the following vapour pressure composition graph

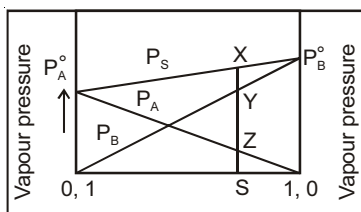

Hence, which is correct?

- (A) Vapour pressure of A = SZ (B) Vapour pressure of B = ZY
 (C) Vapour pressure of B = SY (D) Vapour pressure of solution at X = SZ + SY
27. Which of the following statements is/are correct about Cu^{2+} and Cu^+ in aqueous state?
- (A) Cu^{2+} is more stable than Cu^+ (B) Cu^{2+} is paramagnetic, Cu^+ is diamagnetic
 (C) Cu^{2+} is mostly blue, whereas Cu^+ is colourless (D) Cu^+ is more stable than Cu^{2+}

28. $K_4[Fe(CN)_6]$ is used to detect
- (A) Cu^{2+} (B) As^{3+}
(C) Zn^{2+} (D) Fe^{3+}
29. Which of the following statements is correct for s-block metals?
- (A) On descending down the group hydration energy decrease for metal cations
(B) Only BeF_2 is soluble whereas MgF_2 , CaF_2 , SrF_2 and BaF_2 are insoluble in water
(C) For the halides of alkaline earth metals, tendency to form hydrates gradually decrease down the group?
(D) $BeSO_4$ is soluble whereas $BaSO_4$ is insoluble
30. Lactose is found in milk and is also known as milk sugar. Which of the following is/are correct about lactose? (Molecular formula of lactose is $C_{12}H_{22}O_{11}$)
- (A) Reducing sugar
(B) Hydrolysis product of lactose is galactose + glucose
(C) Hydrolysis product of lactose is glucose + fructose
(D) β -1 \rightarrow 4 glycosidic linkage
31. Glycerol changes to acrolein in presence of
- (A) Conc. H_2SO_4 (B) HNO_3
(C) $KHSO_4$ (D) Anhy. $CaCl_2$
32. Cyclohexene is heated with acidified $KMnO_4$ to form P.
- $$P \xrightarrow{NH_3, \Delta} Q \xrightarrow{LiAlH_4} R$$
- Product R is made to react with more of P to give product G then
- (A) Product P will give Lucas test
(B) Product R may dissolve in HCl
(C) Product Q can give Hoffmann Bromamide reaction
(D) Product G is a polyamide

SECTION - 3

Paragraph Type

This section contains 2 paragraphs. Based on each paragraph, there are 2 questions. Each question has 4 choices (A), (B), (C) and (D) out of which **ONLY ONE** is correct.

Paragraph - 1 (Q. Nos. 33 & 34)

The specific test for Fe^{3+} even in presence of Fe^{2+}

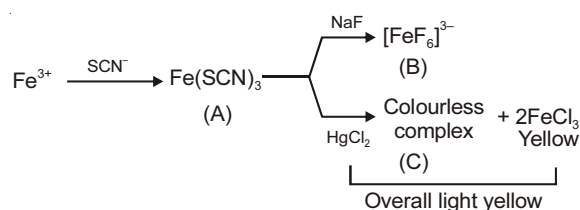

33. Colour of complex (A) in reaction
- (A) Black ppt.
(B) Yellow ppt.
(C) Blood red ppt.
(D) Colourless complex
34. Complex C is
- (A) $Hg[Cl_2]$
(B) $Fe[F_4]^{3-}$
(C) $Hg(SCN)_2$
(D) Both (B) & (C)

Paragraph - 2 (Q. Nos. 35 & 36)

A solution of alanine hydrochloride $[\text{H}_3\text{N}-\text{CH}(\text{CH}_3)-\text{COOH}]^+\text{Cl}^-$ is titrated with a solution of NaOH to produce a curve as follows :
 K_1 and K_2 of alanine hydrochloride are 4.6×10^{-3} and 2.0×10^{-10} respectively,

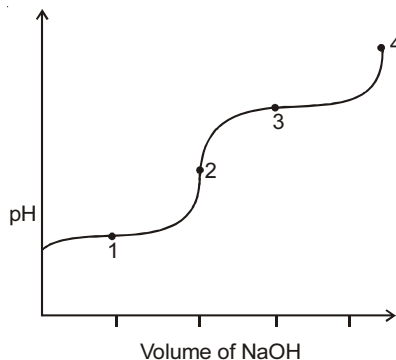

35. The pH at point 3 is
 (A) 2.34 (B) 6.02
 (C) 9.7 (D) 11.2
36. In the curve, at point 4 which of the molecule is found?
 (A) $\text{H}_3\text{N}^+ - \text{CH}(\text{CH}_3) - \text{COOH}$ (B) $\text{H}_3\text{N}^+ - \text{CH}(\text{CH}_3) - \text{COO}^-$
 (C) $\text{H}_2\text{N} - \text{CH}(\text{CH}_3) - \text{COOH}$ (D) $\text{H}_2\text{N} - \text{CH}(\text{CH}_3) - \text{COO}^-$

PART - III : MATHEMATICS

SECTION - 1

Only One Option Correct Type

This section contains 7 multiple choice questions. Each question has 4 choices (A), (B), (C) and (D) out of which **ONLY ONE** is correct.

37. If $\sigma(n) = \sum_{r=1}^n (r^2 \binom{n}{r} - n \binom{n}{r-1}) + (2r+1) \binom{n}{r}$, then $\sigma(50)$ is equal to
 (A) 2400 (B) 2500
 (C) 2600 (D) 2700
38. $px + qy = 40$ is a chord (which is not a tangent) of minimum length of the circle $(x - 10)^2 + (y - 20)^2 = 729$. If the chord passes through $(5, 15)$, then $(p^{2017} + q^{2017})$ is equal to
 (A) Zero (B) 1
 (C) 2^{2017} (D) 2^{2018}
39. The shortest distance between the lines $2x + y + z - 1 = 0 = 3x + y + 2z - 2$ and $x = y = z$, is
 (A) $\frac{1}{\sqrt{2}}$ (B) $\frac{1}{\sqrt{3}}$
 (C) $\frac{\sqrt{3}}{2}$ (D) $\frac{1}{2}$
40. $\int \frac{x^7 - x^5 + x^3 - x}{x^{10} + 1} dx$ is equal to
 (A) $\frac{1}{10} \ln \left(\frac{x^{10} + 1}{(x^2 + 1)^5} \right) + C$ (B) $\frac{1}{5} \ln \left(\frac{x^{10} + 1}{(x^3 + 1)^4} \right) + C$
 (C) $\frac{1}{5} \ln \left(\frac{x^8 + 1}{(x^2 + 1)^4} \right) + C$ (D) $\frac{1}{10} \ln \left(\frac{x^8 + 1}{(x^2 + 1)^4} \right) + C$

41. The function $f(x) = [x] (x^2 - 25)^n ((x^2 + 3)(x^2 + 3x + 4)^3)^m$, $m, n \in N$ attains a local minima at $x = 5$. ([.] denotes the greatest integer function), then
- (A) $m = 10, n = 5$ (B) $m = 5, n = 10$
 (C) $m = 20, n = 5$ (D) $m = 10, n = 3$
42. The number of integers belonging to $[-15, 15]$ but not belonging to the range of the function $f(x) = x\{x\} - x[-x]$. (Where $[]$ and $\{ \}$ denote the greatest integer function and fractional part function respectively.)
- (A) 18 (B) 17
 (C) 16 (D) 15
43. A continuous, even periodic function f with period 8, is such that $f(0) = 0, f(1) = -2, f(2) = 1, f(3) = 2$ and $f(4) = 3$. If $k = (f(-5) + f(20) + f(17))$, then a function, $g : R \rightarrow R$ given by $g(x) = x^k + |\sin x|$, is
- (A) One-one (B) Onto
 (C) Bijective (D) Into

SECTION - 2

One or More Options Correct Type

This section contains 7 multiple choice questions. Each question has 4 choices (A), (B), (C) and (D) out of which **ONE OR MORE** is/are correct.

44. If ABC is a triangle in which $\sqrt{3} \sin C + \tan A = 2 \sec A$ and the longest side is of length 4 units, then (notations used here have their usual meanings in triangle ABC)
- (A) $s = 2 + \sqrt{3}$ (B) $r = \sqrt{3} - 1$
 (C) $R = 2$ (D) $B = \frac{\pi}{3}$
45. Let f be a differentiable function in (m, n) . If $f(x) f'(x) \geq x \sqrt{(f(x))^8 - (f(x))^4}$, and $\lim_{x \rightarrow m^+} (f(x))^2 = 1$ and $\lim_{x \rightarrow n^-} (f(x))^2 = 2$, then $|m^2 - n^2|$ cannot be equal to
- (A) $\frac{2}{3}$ (B) 1
 (C) $\frac{4}{3}$ (D) $\frac{5}{3}$
46. Let $\langle a_i \rangle, i = 1, 2, \dots, 100$ be a given sequence. It is given that a_i is i less than the sum of other 99 numbers for $i = 1, 2, \dots, 100$. If $S = \sum_{i=1}^{100} a_i$, then which of the following assume integral value?
- (A) $7S$ (B) $21S$
 (C) $35S$ (D) $49S$
47. The maximum and minimum value of $x_1^2 + x_2^2 - 12x_1 - 4x_2 + 36$ if $4x_1^2 + 9x_2^2 + 4 = 8x_1 + 36x_2$ (where x_1, x_2 are real numbers), are m and n respectively, then
- (A) $\sqrt{m} + \sqrt{n} = 15$ (B) $\sqrt{m} - \sqrt{n} = 4$
 (C) $m + n = 60$ (D) $m - n = 60$
48. Virat tosses a coin. There is one point for throwing a tail and 2 points for throwing a head. He repeatedly tosses the coin till he gets a sum of points equal to 7. If p be the probability of getting a sum equal to 7, then
- (A) $p > \frac{1}{2}$ (B) $p > \frac{3}{5}$
 (C) $p > 0.65$ (D) $p > 0.7$

49. If the equation $|x^2 - 7x + 10| - mx + 10m = 0$ has k distinct solutions, then
- (A) If $k = 3$, then $m = \{-13 - 4\sqrt{10}\}$ (B) If $k = 4$, then $m \in (-13 + 4\sqrt{10}, 0)$
- (C) If $k = 2$, then $m \in (-13 + 4\sqrt{10}, 0)$ (D) If $k = 3$, then $m = \{-13 + 4\sqrt{10}\}$
50. A line given by $y = \alpha$, intersects the curve $y = x - 4x^3$ at the points $A(x_1, \alpha)$ and $B(x_2, \alpha)$ (where $x_1 < x_2$) in first quadrant. If the area bounded by y -axis, the curve and the line $y = \alpha$ is equal to the area bounded by the line $y = \alpha$ and the curve in first quadrant, then
- (A) $3\alpha - x_2 = 1$ (B) $3\alpha - x_2 = 0$
- (C) $\alpha^2 + x_2^2 = \frac{5}{27}$ (D) $\alpha x_2 = \frac{1}{18}$

SECTION - 3

Paragraph Type

This section contains 2 paragraphs. Based on each paragraph, there are 2 questions. Each question has 4 choices (A), (B), (C) and (D) out of which **ONLY ONE** is correct.

Paragraph - 1 (Q. Nos. 51 & 52)

A hyperbola $H \equiv 2x^2 - 2y^2 = 1$ intersects an ellipse $E \equiv \frac{x^2}{p^2} + \frac{y^2}{q^2} = 1$ orthogonally. The eccentricity of the ellipse E is half that of the hyperbola H .

51. The equation of E is given by

- (A) $\frac{x^2}{4} + \frac{y^2}{2} = 1$ (B) $\frac{x^2}{9} + \frac{y^2}{4} = 1$
- (C) $\frac{x^2}{2} + \frac{y^2}{4} = 1$ (D) $\frac{x^2}{2} + \frac{y^2}{1} = 1$

52. The coordinates of the point from where two mutually perpendicular tangents to E can be drawn, are

- (A) (1, 2) (B) (2, 1)
- (C) $(\sqrt{2}, 1)$ (D) $(-1, 2)$

Paragraph - 2 (Q. Nos. 53 & 54)

z_1, z_2 and z_3 are complex numbers such that $|z_1| = |z_2| = |z_3| = 1$ and $\frac{z_1^2}{z_2 z_3} + \frac{z_2^2}{z_3 z_1} + \frac{z_3^2}{z_1 z_2} + 1 = 0$

53. Sum of all the integral values of $|z_1 + z_2 + z_3|$ is equal to

- (A) Zero (B) 1
- (C) 2 (D) 3

54. If $|z_1 + z_2 + z_3| = k$ where k , is the greatest integral value of $|z_1 + z_2 + z_3|$, then $\text{Re}(z_1 \bar{z}_2 + z_2 \bar{z}_3 + z_3 \bar{z}_1)$ equals

- (A) $\frac{1}{\sqrt{2}}$ (B) $\frac{1}{2}$
- (C) 1 (D) 2



QR Code



To get quick video Solution of Mock Test Paper (Paper-2), follow the steps below:

1. Scan QR Code

2. Don't have QR reader? Download Aakash i-Tutor app from Google play or App Store and scan the QR Code.

Time : 3 Hrs.

MM : 183

Mock Test

for JEE(Advanced)-2018

Paper - I (Code-A)

ANSWERS

PHYSICS

1. (A, D)
2. (B, C)
3. (A, D)
4. (A, C, D)
5. (A, C)
6. (A, B, C)
7. (A, B, D)
8. (5)
9. (2)
10. (3)
11. (3)
12. (8)
13. (B)
14. (C)
15. (D)
16. (C)
17. (B)
18. (A)

CHEMISTRY

19. (A)
20. (D)
21. (B)
22. (D)
23. (C)
24. (D)
25. (B)
26. (4)
27. (5)
28. (5)
29. (3)
30. (3)
31. (C)
32. (C)
33. (D)
34. (C)
35. (C)
36. (B)

MATHEMATICS

37. (A, C)
38. (A, B, D)
39. (B, C)
40. (B, D)
41. (A, B, D)
42. (A, B, C, D)
43. (A, B, D)
44. (9)
45. (8)
46. (0)
47. (4)
48. (6)
49. (B)
50. (D)
51. (C)
52. (A)
53. (C)
54. (C)



ANSWERS & HINTS

PART - I (PHYSICS)

1. Answer (A, D)

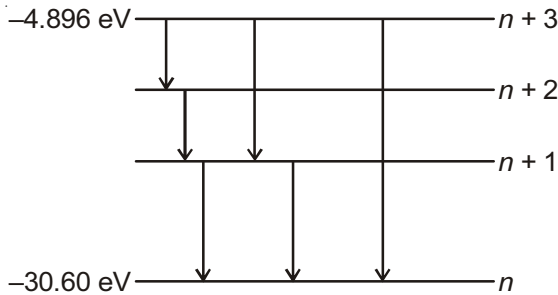

For the emission of six spectral lines, there must be four energy levels.

Thus two more levels are in between -30.6 eV and -4.896 eV.

If n represents the energy level of energy -30.60 eV, then $(n + 3)$ represent the energy level of energy -4.896 eV.

$$\therefore -13.6 \frac{Z^2}{n^2} = -30.6 \text{ eV} \quad \dots(i)$$

$$-13.6 \frac{Z^2}{(n+3)^2} = -4.896 \text{ eV} \quad \dots(ii)$$

Solving equations (i) & (ii)

$$Z = 3, n = 2$$

The smallest wavelength corresponding to maximum energy difference transition.

$$\therefore \lambda_{\min} = \frac{1240 \text{ eV-nm}}{[-4.896 - (-30.60)]\text{eV}} = 482 \text{ \AA}$$

2. Answer (B, C)

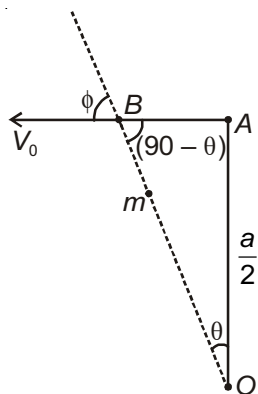

Let the line joining running man, car and centre makes an angle θ with vertical OA , at any time t .

$$AB = \frac{a}{2} \tan \theta$$

Velocity of observer (man) in the car at time t .

$$(V_0)_{\text{car}} = \frac{d}{dt}(AB)$$

$$= \frac{a}{2} \sec^2 \theta \cdot \frac{d\theta}{dt} \text{ but } \frac{d\theta}{dt} = \omega = 22 \text{ rad/s}$$

$$\therefore (V_0)_{\text{car}} = 11a \sec^2 \theta$$

Now, apparent frequency heard by observer(man) in the car at time t .

$$n' = \left[\frac{V - V_0 \cos \phi}{V} \right] n$$

where V = velocity of sound in air

and ϕ = angle between velocity vector of observer car and the line joining man in car and centre.

$$\therefore n' = \left[\frac{V - 11a \sec^2 \theta \sin \theta}{V} \right] n$$

But $\sec^2 \theta \sin \theta$ is a increasing function in the range

$$0 \leq \theta \leq \frac{\pi}{2}$$

n' will be minimum when $\sec^2 \theta \sin \theta$ is maximum, which occurs at $\theta = 45^\circ$, because after that direction of velocity of car will alter.

$$\therefore (n')_{\min} = \left(\frac{V - 11a\sqrt{2}}{V} \right) n = \frac{330 - 110}{330} \times 300 = 200 \text{ Hz}$$

3. Answer (A, D)

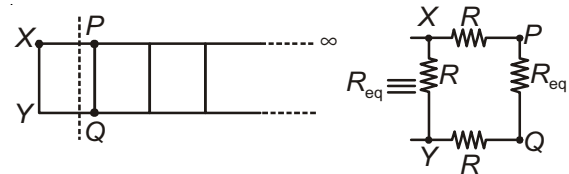

Equivalent thermal resistance between X & Y .

$$\frac{1}{R_{\text{eq}}} = \frac{1}{(R + R_{\text{eq}} + R)} + \frac{1}{R} \text{ where } R = \frac{l}{kA}$$

$$\text{On solving } R_{\text{eq}} = R(\sqrt{3} - 1) = \frac{l(\sqrt{3} - 1)}{kA}$$

$$\therefore \text{Rate of heat flow between } X \text{ \& } Y = \frac{\theta_1 - \theta_2}{R_{\text{eq}}}$$

$$= \frac{kA(\theta_1 - \theta_2)}{l(\sqrt{3} - 1)}$$

4. Answer (A, C, D)

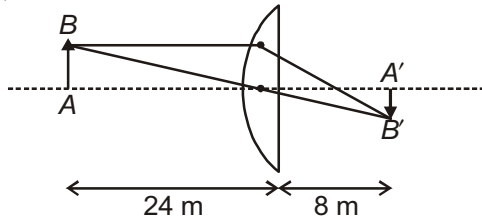

$$\mu = \frac{\lambda_a}{\lambda_m} = \frac{3}{2}$$

$$\frac{1}{f} = \frac{(\mu - 1)}{R} = \frac{\left(\frac{3}{2} - 1\right)}{R}$$

$$\Rightarrow \frac{1}{f} = \frac{1}{2R}$$

From thin lens formula

$$\Rightarrow \frac{1}{f} = \frac{1}{v} - \frac{1}{u}$$

$$\Rightarrow \frac{1}{2R} = \frac{1}{8} - \frac{1}{(-24)}$$

$$\Rightarrow R = 3 \text{ m}$$

$$f = 6 \text{ m}$$

5. Answer (A, C)

$$\phi_i = BA \cos 0 = BA$$

$$\phi_f = 0$$

$$|\Delta\phi| = |\phi_f - \phi_i| = BA$$

$$\text{Average induced emf} = \frac{BA}{t}$$

$$= \frac{1.2 \times \pi [0.05]^2}{0.2}$$

$$= 0.047 \text{ volts}$$

$$\Rightarrow \text{Charge} = \frac{|\Delta\phi|}{R} = 9.42 \times 10^{-4} \text{ C}$$

∴ Direction of current in R is clockwise as the flux decreases, induced field must support the existing field

6. Answer (A, B, C)

If \vec{B} is uniform then L_{eq} for whole wire

$$|\vec{L}_{eq}| = 2(L + R)$$

Net force on wire will be $\vec{F} = I(\vec{L}_{eq} \times \vec{B})$

If $\vec{L}_{eq} \perp \vec{B}$ then $|\vec{F}| = I|\vec{L}_{eq}||\vec{B}|$

$$= 2I(L + R)B$$

If $\vec{L}_{eq} \parallel \vec{B}$ then $\vec{F} = 0$

7. Answer (A, B, D)

$$E_{mix} = \frac{1 \times \frac{3RT}{2} + 1 \times \frac{5RT}{2}}{1+1} = 2RT$$

$$\gamma_{mix} = \frac{3}{2}$$

$$M_{mix} = \frac{1 \times 4 + 1 \times 32}{1+1} = 18$$

$$V_S = \sqrt{\frac{\gamma RT}{M}}$$

$$\frac{V_{mix}}{V_{He}} = \sqrt{\frac{\gamma_{mix} \cdot M_{He}}{\gamma_{He} \cdot M_{mix}}} = \frac{1}{\sqrt{5}}$$

$$V_{rms} \propto \frac{1}{\sqrt{M}}$$

$$\frac{V_{He}}{V_{O_2}} = \sqrt{\frac{M_{O_2}}{M_{He}}} = 2\sqrt{2}$$

8. Answer (5)

$$E = \frac{1242 \text{ eV-nm}}{\lambda(\text{nm})}$$

$$E[\lambda = 108.72 \text{ nm}] = \frac{1242}{108.72} = 11.424 \text{ eV}$$

$$E[\lambda = 30.44 \text{ nm}] = \frac{1242}{30.44} = 40.80 \text{ eV}$$

$$\therefore \text{Total energy emitted } (\Delta E) = (11.424 + 40.80) \text{ eV} = 52.224 \text{ eV}$$

$$\therefore \Delta E = 13.6Z^2 \left[\frac{1}{n_1^2} - \frac{1}{n_2^2} \right]$$

$$52.224 = 13.6 \times 4 \left[\frac{1}{1^2} - \frac{1}{n^2} \right]$$

$$\Rightarrow 1 - \frac{1}{n^2} = 0.96$$

$$\Rightarrow \frac{1}{n^2} = 0.04 = \frac{4}{100}$$

$$\therefore n = 5 \text{ (i.e., 4}^{\text{th}} \text{ excited state)}$$



9. Answer (2)

When B is maximum then rate of disintegration of $A =$ Rate of disintegration of B

$$\therefore \lambda N_1 = (2\lambda) \cdot N_2$$

$$\therefore \frac{N_1}{N_2} = 2$$

10. Answer (3)

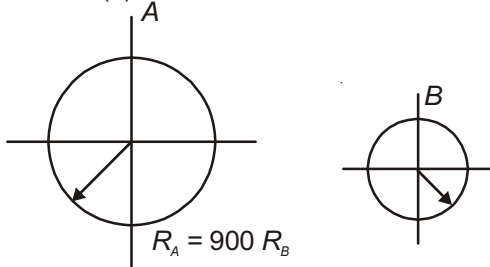

From Wien's displacement law

$$\frac{\lambda_A}{\lambda_B} = \frac{T_B}{T_A}$$

From Stefan's law

$$P = \sigma eAT^4$$

$$\therefore P_A = \sigma e 4\pi [900 R]^2 \times T_A^4$$

$$P_B = \sigma e 4\pi R^2 \times T_B^4$$

$$\text{Given } P_A = 10^4 P_B$$

$$\Rightarrow (900)^2 \times T_A^4 = 10^4 \times T_B^4$$

$$\Rightarrow \frac{T_B}{T_A} = 3$$

11. Answer (3)

$$V_T = \frac{2}{9} r^2 \frac{(\sigma - \rho) g}{\eta}$$

$$\therefore \frac{V_A}{V_B} = \left(\frac{r_A}{r_B}\right)^2 \cdot \left(\frac{\sigma_A - \rho_1}{\sigma_B - \rho_2}\right) \left(\frac{\eta_2}{\eta_1}\right)$$

$$= \left(\frac{2}{1}\right)^2 \left(\frac{9 - 1.8}{9 - 2.6}\right) \left(\frac{2}{3}\right) = 4 \times \frac{7.2}{6.4} \times \frac{2}{3} = 3$$

12. Answer (8)

$$I_{\max} = \frac{10}{\left(\frac{3}{2}\right)} \text{ A}$$

$$I_{\min} = \frac{10}{12} \text{ A}$$

$$\frac{I_{\max}}{I_{\min}} = \frac{12 \times 2}{3} = 8$$

13. Answer (B)

14. Answer (C)

$$FR - fR = \frac{2}{5} M \frac{a}{R}$$

$$F - f = \frac{2}{5} Ma$$

$$F + f = Ma$$

$$2F = \frac{7}{5} Ma$$

$$\Rightarrow Ma = \frac{10F}{7}$$

$$\Rightarrow a = \frac{10F}{7M}$$

$$\Rightarrow f = F - \frac{4F}{7} = \frac{3F}{7} \quad (F = 0.6 Mg)$$

$$f = \frac{3}{7} \times 0.6Mg = \frac{1.8}{7} Mg$$

$$\Rightarrow \mu = \frac{1.8}{7} = \frac{9}{35}$$

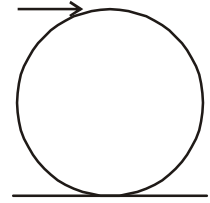

15. Answer (D)

$$F - f = Ma$$

$$F 0.3 R + fR = \frac{2}{5} MR^2 \cdot \frac{a}{R}$$

$$0.3 F + f = \frac{2}{5} Ma$$

$$1.3 F = \frac{7}{5} Ma$$

$$\Rightarrow Ma = \frac{6.5 F}{7}$$

$$f = \frac{0.5 F}{7} = \frac{F}{14}$$

16. Answer (C)

17. Answer (B)

18. Answer (A)

PART - II (CHEMISTRY)

19. Answer (A)

Energy of photon = ΔE

$$\begin{aligned}\Delta E &= 2.18 \times 10^{-18} \left[\frac{1}{n_1^2} - \frac{1}{n_2^2} \right] Z^2 \\ &= 2.18 \times 10^{-18} \left[\frac{1}{(1)^2} - \frac{1}{(2)^2} \right] (3)^2 \\ &= 2.18 \times 9 \times \frac{3}{4} \times 10^{-18} \\ &= 14.715 \times 10^{-18} \text{ J}\end{aligned}$$

Ionisation energy of hydrogen = $2.18 \times 10^{-18} \text{ J}$ $E = E_0 + \text{kinetic energy of electron}$ K.E. = $E - E_0$ K.E. = $(14.715 - 2.18) \times 10^{-18}$ K.E. = $12.535 \times 10^{-18} \text{ J}$

20. Answer (D)

Availability of electrons is more due to absence of resonance.

21. Answer (B)



Now

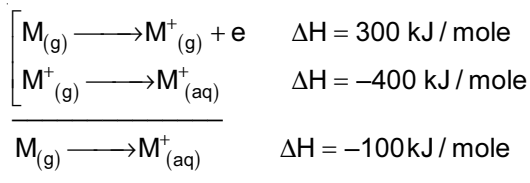

Similarly

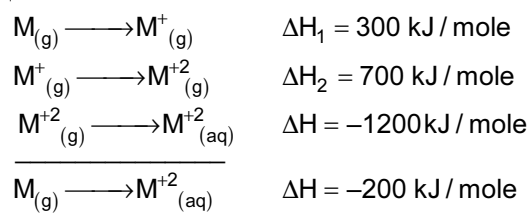
 $M^{2+}_{(aq)}$ is more stable than $M^+_{(aq)}$ since ΔH is more negative hence more stability of ion.

22. Answer (D)

23. Answer (C)

$$\begin{aligned}n_{(\text{NO})} &= \frac{1.5 \times 0.2}{300 \times 0.0821} \\ &= 0.012\end{aligned}$$

$$\begin{aligned}n_{(\text{O}_2)} &= \frac{0.5 \times 0.15}{300 \times 0.0821} \\ &= 3.045 \times 10^{-3}\end{aligned}$$

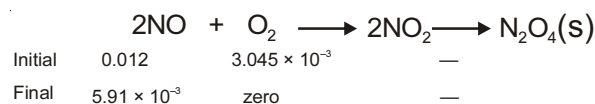
Now, gases react, here O_2 act as limiting reagent[Since N_2O_4 is solidified so only NO exert pressure]

24. Answer (D)

 Mn^{+2} , CO^{+2} , Ni^{+2} ions are precipitated as sulphide in alkaline medium. Their K_{sp} is high

25. Answer (B)

26. Answer (4)

Glucose, Fructose, HCOOH , $\text{CH}_3\text{CH}_2\text{CHO}$

27. Answer (5)

(a), (c), (e), (f) and (g) are coloured

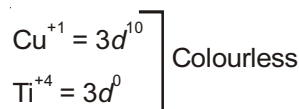
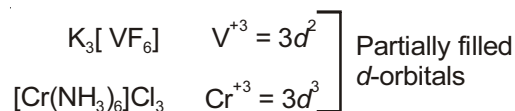

28. Answer (5)

Statement (i) is false



29. Answer (3)

Gram equivalent of KMnO_4 = gram equivalent of FeC_2O_4

$$N_1 V_1 = \frac{w}{\text{Eq.wt.}}$$

$$0.1 \times V_1 = \frac{14.4}{144} \times 3$$

$$V_1 = 3 \text{ litres}$$

$$n \text{ factor of } \text{KMnO}_4 = 5$$

$$n \text{ factor of } \text{FeC}_2\text{O}_4 = 3$$

30. Answer (3)

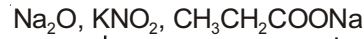

Salt of strong base and weak acid

31. Answer (C)

32. Answer (C)

33. Answer (D)

34. Answer (C)

35. Answer (C)

36. Answer (B)

PART - III (MATHEMATICS)

37. Answer (A, C)

Equation of chord of hyperbola $\frac{x^2}{16} - \frac{y^2}{9} = 1$

Whose middle point be (h, k) is

$$\frac{xh}{16} - \frac{ky}{9} = \frac{h^2}{16} - \frac{k^2}{9}; \text{ (Using } T = S_1\text{)}$$

It passes through $(4, 2)$

$$\therefore \frac{4h}{16} - \frac{2k}{9} = \frac{h^2}{16} - \frac{k^2}{9}$$

$$\Rightarrow 36h - 32k = 9h^2 - 16k^2$$

$$\Rightarrow 9h^2 - 36h - 16k^2 + 32k = 0$$

$$\Rightarrow 9(h^2 - 4h) - 16(k^2 - 2k) = 0$$

$$\Rightarrow 9(h^2 - 4h + 4) - 16(k^2 - 2k + 1) = 36 - 16$$

$$\Rightarrow \frac{(h-2)^2}{\frac{20}{9}} - \frac{(k-1)^2}{\frac{20}{16}} = 1$$

$$\boxed{\frac{(x-2)^2}{\frac{20}{9}} - \frac{(y-1)^2}{\frac{20}{16}} = 1}$$

Clearly centre be $(2, 1)$ and eccentricity be $\frac{5}{4}$.

38. Answer (A, B, D)

Let $A = \begin{bmatrix} a_{11} & a_{12} & a_{13} \\ a_{21} & a_{22} & a_{23} \\ a_{31} & a_{32} & a_{33} \end{bmatrix}$, Then $B = \begin{bmatrix} a_{11} & \frac{a_{12}}{5} & \frac{a_{13}}{5^2} \\ 5a_{21} & a_{22} & \frac{a_{23}}{5} \\ 5^2 a_{31} & 5a_{32} & a_{33} \end{bmatrix}$,

$$\Rightarrow |B| = \begin{vmatrix} a_{11} & a_{12} & a_{13} \\ a_{21} & a_{22} & a_{23} \\ a_{31} & a_{32} & a_{33} \end{vmatrix} = |A|.$$

$$\Rightarrow |B| = 600 = 2^3 \times 3^1 \times 5^2$$

$$\Rightarrow \lambda = 2^3 \cdot 3^1 \cdot 5^2$$

Number of odd divisors of λ is $(1+1)(2+1) = 2 \times 3 = 6$

Number of divisors of λ which are perfect square we consider $2^0, 2^2$ and $5^0, 5^2$

\therefore The number of such divisors is $2 \times 2 = 4$

Number of divisors of λ which are even is

$$3 \times 2 \times 3 = 18$$

Number of divisors of λ which are divisible by 24 is $2 + 1 = 3$

39. Answer (B, C)

Let image of $P(3, 5, 7)$ w.r.t the plane mirror $2x + y - z = 10$, is $Q(\alpha, \beta, \gamma)$

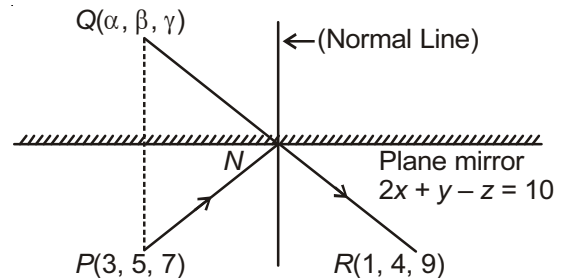

$$\therefore \frac{\alpha-3}{2} = \frac{\beta-5}{1} = \frac{\gamma-7}{-1}$$

$$= \frac{-2[(2)(3) + (1)(5) + (-1)(7) - 10]}{2^2 + 1^2 + (-1)^2}$$

$$\Rightarrow \frac{\alpha-3}{2} = \frac{\beta-5}{1} = \frac{\gamma-7}{-1} = \frac{12}{6} = 2$$

$$\Rightarrow \alpha = 7, \beta = 7, \gamma = 5$$

$$\Rightarrow Q = (7, 7, 5)$$

Now equation of QR is $\frac{x-1}{6} = \frac{y-4}{3} = \frac{z-9}{-4}$

which intersect the plane at $N = \left(\frac{97}{19}, \frac{115}{19}, \frac{119}{19}\right)$.

40. Answer (B, D)

Equation of tangent

$$Y - y = \frac{dy}{dx}(X - x)$$

We get, coordinate of $N = \left(0, y - x \frac{dy}{dx}\right)$

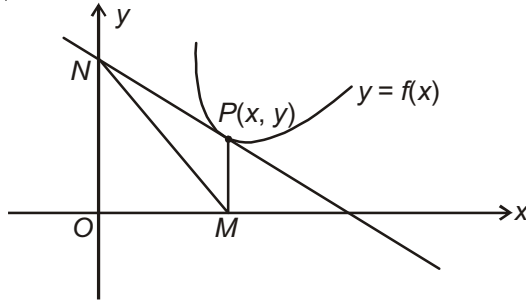

$$\Rightarrow ON = y - x \frac{dy}{dx}$$

and $OM = x$.

$$\text{Given area of } \triangle MON = \frac{1}{2}OM \times ON = 2$$

$$\Rightarrow x \left(y - x \frac{dy}{dx} \right) = 4$$

$$\Rightarrow \frac{dy}{dx} - \frac{1}{x}y = \frac{-4}{x^2}$$

$$\therefore \text{I.F. } e^{-\int \frac{dx}{x}} = e^{-\log x} = \frac{1}{x}$$

$$\therefore \text{Solution is } y \cdot \frac{1}{x} = -\int \frac{4}{x^3} dx + C$$

$$\frac{y}{x} = \frac{2}{x^2} + C, \text{ which passes through } (1, 1)$$

$$\therefore C = -1$$

$$\therefore \text{Equation of curve is } x^2 + xy - 2 = 0$$

which is hyperbola.

41. Answer (A, B, D)

$$f(x) = \begin{cases} \max \{-x, x^2\}; & -1 \leq x < 0 \\ \min \{x^2, (x-2)^2\}; & 0 \leq x \leq 2 \\ \max \{4-x, 6x-x^2-8\}; & 2 < x \leq 4 \end{cases}$$

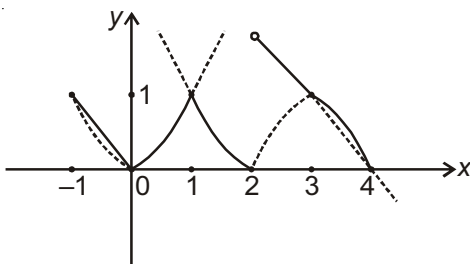

From the graph we clearly see $f(x)$ is discontinuous at $x = 2$ and non-differentiable at $x = 0, 1, 2$ and 3 .

$f(x)$ has local maxima at $x = 1$, i.e., at one point

$f(x)$ has local minima at $x = 0$ & $x = 2$ i.e., at two points.

42. Answer (A, B, C, D)

Let ' α ' be the real root of given equation then

$$\alpha^3 + (3 + 2i)\alpha + (-1 + i\lambda) = 0 \quad \dots(1)$$

$$\overline{\alpha^3 + (3 + 2i)\alpha + (-1 + i\lambda)} = 0$$

$$\Rightarrow \alpha^3 + (3 - 2i)\alpha + (-1 - i\lambda) = 0 \quad \dots(2)$$

$$(1) - (2), \Rightarrow 4i\alpha + 2i\lambda = 0$$

$$\Rightarrow \alpha = -\frac{\lambda}{2} \text{ substitute in (1)}$$

$$-\frac{\lambda^3}{8} + (3 + 2i)\left(-\frac{\lambda}{2}\right) + (-1 + i\lambda) = 0$$

$$-\lambda^3 + 4(3 + 2i)(-\lambda) + 8(-1 + i\lambda) = 0$$

$$\Rightarrow -\lambda^3 - 12\lambda - 8i\lambda - 8 + 8i\lambda = 0$$

$$\Rightarrow \lambda^3 + 12\lambda + 8 = 0$$

Now we discuss location of roots of $f(\lambda) = 0$;

$$\text{when } f(\lambda) = \lambda^3 + 12\lambda + 8$$

$$f'(\lambda) = 3\lambda^2 + 12 > 0, \forall \lambda \in \mathbb{R}$$

$$\text{Now } f(-1) = -ve, f(0) = +ve$$

$$\therefore \lambda \in (-1, 0)$$

43. Answer (A, B, D)

Given that $E_1, E_2, \dots, E_{1008}$ are independent events.

Therefore $E'_1, E'_2, \dots, E'_{1008}$ are also independent events.

$$\text{Given that } P(E_i) = \frac{i}{2i+1}; (i = 1, 2, \dots, 1008)$$

Then the probability that none of the events occurs

$$= (1 - P(E_1))(1 - P(E_2)) \dots (1 - P(E_{1008}))$$

$$= \left(1 - \frac{1}{3}\right)\left(1 - \frac{2}{5}\right)\left(1 - \frac{3}{7}\right)\left(1 - \frac{4}{9}\right) \dots \left(1 - \frac{1008}{2017}\right)$$

$$= \frac{2}{3} \cdot \frac{3}{5} \cdot \frac{4}{7} \cdot \frac{5}{9} \dots \frac{1009}{2017}$$

$$= \frac{(1009!)2.4.6 \dots 2016}{2.3.4.5.6.7 \dots 2016.2017}$$

$$= \frac{(1009!)2^{1008} \cdot (1.2.3 \dots 1008)}{2017!}$$

$$= \frac{(1008!)(1009!) \cdot 2^{1008}}{2017!}$$

$$\therefore b = 1008, c = 1009 \text{ and } d = 2017$$

44. Answer (9)

$$\lim_{x \rightarrow \infty} \left(\frac{x^3 + 4x^2 + 3x + 5}{x^2 + 2x + 3} + lx + m \right) = 10$$

$$\Rightarrow \lim_{x \rightarrow \infty} \left(\frac{x^3 + 4x^2 + 3x + 5 + lx^3 + (2l + m)x^2 + (3l + 2m)x + 3m}{x^2 + 2x + 3} \right) = 10$$

$$\Rightarrow \lim_{x \rightarrow \infty} \frac{(l+1)x^3 + (2l+m+4)x^2 + (3l+2m+3)x + 3m+5}{x^2 + 2x + 3} = 10$$

$$\Rightarrow l + 1 = 0, \quad 2l + m + 4 = 10$$

$$\therefore l = -1, \quad m = 8$$

Then value of $l^2 + m = 9$

45. Answer (8)

$$\text{Given that } f(x) = 1 + \frac{x^3}{3} + \int_0^x e^{-t} f(x-t) dt,$$

Replace t by $x - t$, we get

$$f(x) = 1 + \frac{x^3}{3} + \int_0^x e^{-x+t} f(t) dt$$

$$f(x) = 1 + \frac{x^3}{3} + e^{-x} \int_0^x e^t f(t) dt \quad \dots(1)$$

Now differentiate both sides w.r.t. x , we get

$$f'(x) = x^2 + e^{-x} e^x f(x) - e^{-x} \int_0^x e^t f(t) dt \quad \dots(2)$$

Now (1) + (2), we get

$$f'(x) + f(x) = 1 + x^2 + \frac{x^3}{3} + f(x)$$

$$\Rightarrow f'(x) = 1 + x^2 + \frac{x^3}{3}$$

$$\Rightarrow f(x) = x + \frac{x^3}{3} + \frac{x^4}{12} + C$$

But from (1) we have $f(0) = 1$

$$\Rightarrow C = 1$$

$$\therefore f(x) = x + \frac{x^3}{3} + \frac{x^4}{12} + 1$$

Now,

$$\int_0^1 f(x) dx = x + \frac{x^2}{2} + \frac{x^4}{12} + \frac{x^5}{60} \Big|_0^1 = 1 + \frac{1}{2} + \frac{1}{12} + \frac{1}{60}$$

$$= \frac{60 + 30 + 5 + 1}{60} = \frac{96}{60} = \frac{8}{5}$$

$$\Rightarrow p = \frac{8}{5} \Rightarrow 5p = 8$$

46. Answer (0)

 $\therefore a_1, a_2, \dots, a_n$ are in AP

$$\Rightarrow a_2 - a_1 = a_3 - a_2 = \dots = a_n - a_{n-1} = 'd'$$

$$\therefore S = d \left(\frac{1}{\sqrt{a_1} + \sqrt{a_2}} + \frac{1}{\sqrt{a_2} + \sqrt{a_3}} + \dots + \frac{1}{\sqrt{a_{n-1}} + \sqrt{a_n}} \right)$$

$$= - \left(\frac{a_1 - a_2}{\sqrt{a_1} + \sqrt{a_2}} + \frac{a_2 - a_3}{\sqrt{a_2} + \sqrt{a_3}} + \dots + \frac{a_{n-1} - a_n}{\sqrt{a_{n-1}} + \sqrt{a_n}} \right)$$

$$= -(\sqrt{a_1} - \sqrt{a_2} + \sqrt{a_2} - \sqrt{a_3} + \dots + \sqrt{a_{n-1}} - \sqrt{a_n})$$

$$= -(\sqrt{a_1} - \sqrt{a_n}) = -(\sqrt{100} - \sqrt{900})$$

$$= -(10 - 30)$$

$$S = 20$$

$$\boxed{S - 20 = 0}$$

47. Answer (4)

$$\text{Let } \vec{a} = \lambda x^2 \hat{i} + \hat{j} + 5\hat{k} \text{ and } \vec{b} = \hat{i} + \lambda x \hat{j} + 5\hat{k}$$

According to given condition $\vec{a} \cdot \vec{b} > 0$

$$\Rightarrow \lambda x^2 + \lambda x + 25 > 0, \quad \forall x \in \mathbb{R}$$

$$\text{i.e., } \lambda^2 - 100\lambda < 0 \text{ \& } \lambda > 0$$

$$\Rightarrow \lambda(\lambda - 10) < 0 \text{ \& } \lambda > 0$$

$$\Rightarrow \lambda \in (0, 10)$$

 $\lambda = 1, 8, 27$ & 64 are perfect cube

48. Answer (6)

$$\text{Given that } x^2 + y^2 - 6x - 8y = 0$$

$$(x - 3)^2 + (y - 4)^2 = 5^2$$

$$\text{i.e., } x = 3 + 5\cos\theta, y = 4 + 5\sin\theta$$

$$\begin{aligned} \therefore a &= \max\{x + y\} = \max\{7 + 5\cos\theta + 5\sin\theta\} \\ &= 7 + 5\sqrt{2} \end{aligned}$$

$$\begin{aligned} b &= \min\{x - y\} = \min\{-1 + 5\cos\theta - 5\sin\theta\} \\ &= -1 - 5\sqrt{2} \end{aligned}$$

$$\therefore a + b = 6$$

49. Answer (B)

50. Answer (D)

51. Answer (C)

52. Answer (A)

53. Answer (C)

54. Answer (C)

Solution for Question Nos. 52. to 54.

Equation of tangent to curve $x^2 + y^2 + 4y - 1 = 0$ at point (1, -4) is: $x - 2y - 9 = 0$

Equation of normal to circle is: $x - y - 2 = 0$

Equation of tangent to curve $x^2 + y^2 - 4x - 4y + 7 = 0$ at point (3, 2) is: $x - 3 = 0$

Equation of normal to circle is: $x - y = 0$

Equation of tangent to $3x^2 - y^2 = 3$ at point (2,3) is: $2x - y - 1 = 0$

Equation of normal to hyperbola is $x + 2y - 8 = 0$

Equation of tangent to $y^2 - 16x - 4y - 48 = 0$ at the point (-3, 4) is: $4x - y + 16 = 0$

Equation of normal to parabola is: $4x - 4y - 27 = 0$



Time : 3 Hrs.

MM : 183

Mock Test

for JEE(Advanced)-2018

Paper - 2 (Code-B)

ANSWERS

PHYSICS

1. (D)
2. (A)
3. (B)
4. (B)
5. (D)
6. (A)
7. (A)
8. (A, B)
9. (A, C)
10. (A, B)
11. (A, B, C, D)
12. (B, D)
13. (B, D)
14. (A, B, C)
15. (C)
16. (B)
17. (C)
18. (A)

CHEMISTRY

19. (B)
20. (B)
21. (B)
22. (A)
23. (D)
24. (B)
25. (C)
26. (A, C, D)
27. (A, B, C)
28. (A, C, D)
29. (A, B, C, D)
30. (A, B, D)
31. (A, C)
32. (B, C, D)
33. (C)
34. (C)
35. (C)
36. (D)

MATHEMATICS

37. (C)
38. (D)
39. (A)
40. (A)
41. (B)
42. (A)
43. (C)
44. (B, C, D)
45. (C, D)
46. (D)
47. (C, D)
48. (A, B, C)
49. (B, D)
50. (B, C, D)
51. (D)
52. (C)
53. (D)
54. (B)



ANSWERS & HINTS

PART - I (PHYSICS)

1. Answer (D)

$$\text{Heat current } i = -kA \frac{dT}{dx}$$

$$i dx = -kAdT$$

$$\Rightarrow \int_0^l dx = -A\alpha \int_{T_1}^{T_2} TdT$$

$$\Rightarrow il = -\frac{A\alpha}{2}(T_2^2 - T_1^2) = \frac{A\alpha}{2}(T_1^2 - T_2^2)$$

2. Answer (A)

$$B = \alpha(1 + \sin \omega t) \sin \omega_0 t$$

$$B = \alpha\{\sin \omega_0 t + \sin \omega t \sin \omega_0 t\}$$

$$= \alpha\left\{\sin \omega_0 t + \frac{1}{2}\cos(\omega - \omega_0)t - \frac{1}{2}\cos(\omega + \omega_0)t\right\}$$

This light has 3 frequencies and maximum frequency is $\omega_0 + \omega$

Thus maximum KE will be

$$h(\omega + \omega_0) - \phi_{Li}$$

$$= 4.14 \times 10^{-15} \times 10 \times 10^{14} \text{ eV} - 2.39 \text{ eV}$$

$$= 4.14 \text{ eV} - 2.39 \text{ eV} = 1.75 \text{ eV}$$

3. Answer (B)

$$\text{MSD} = 0.05 \text{ cm}$$

$$\text{VSD} = \frac{49}{1000} = 0.049 \text{ cm}$$

$$\text{LC} = 0.05 - 0.049 = 0.001 \text{ cm}$$

$$\text{Diameter} = 5.10 + 24 \times 0.001 = 5.124 \text{ cm}$$

4. Answer (B)

$$R_{Al} = \frac{\rho l}{A} = 3 \times 10^{-5} \Omega = 30 \mu\Omega$$

$$R_{Fe} = \frac{\rho' l'}{A'} = \frac{25}{2} \times 10^{-4} \Omega = 1250 \mu\Omega$$

Given connection is in parallel

$$R = \frac{R_{Al} R_{Fe}}{R_{Al} + R_{Fe}} = \frac{1875}{64} \mu\Omega$$

5. Answer (D)

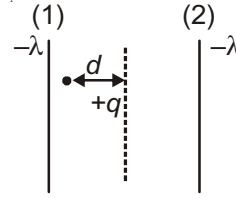

As q is displaced towards wire (1), attractive force due to (1) increases and due to (2) decreases. Thus F_{net} is leftward. \therefore no SHM

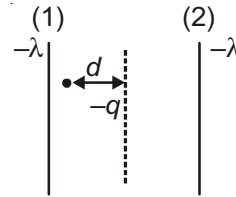

As $-q$ is displaced towards wire (1), repulsive force due to (1) increases and due to (2) decreases. Thus F_{net} is rightward. \therefore SHM

6. Answer (A)

$$x = 0, \text{ path difference } 2\lambda$$

Hence 2nd order maxima obtained

First order

$$S_2 P - S_1 P = \lambda$$

$$\sqrt{x^2 + 4\lambda^2} - x = \lambda$$

$$\text{So } x^2 + 4\lambda^2 = \lambda^2 + x^2 + 2\lambda x$$

$$x = \frac{3}{2}\lambda$$

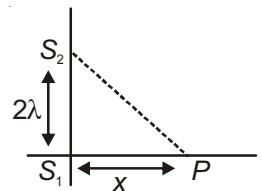

7. Answer (A)

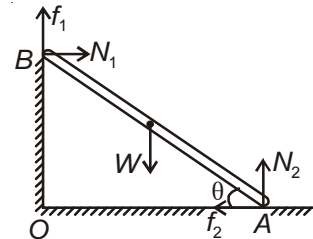

For equilibrium of rod considering limiting friction, we use.

$$N_1 = f_2$$

$$f_1 + N_2 = W$$

$$(f_1)_{\text{max}} = \mu N_1$$

$$(f_2)_{\max} = \mu N_2$$

$$\Rightarrow N_1 = \mu N_2 \text{ \& } \left(\mu N_1 + \frac{N_1}{\mu} \right) = W$$

$$\Rightarrow N_1 \left[\frac{\mu^2 + 1}{\mu} \right] = W$$

Balancing all torques about point A, we use.

$$W \left[\frac{5}{2} \cdot \frac{4}{5} \right] - N_1(3) - f_1(4) = 0$$

$$\Rightarrow 2W - 3N_1 - 4f_1 = 0$$

$$\Rightarrow 2 \cdot \left[\frac{(\mu^2 + 1)}{\mu} N_1 \right] - 3N_1 - 4[\mu N_1] = 0$$

$$\Rightarrow (\mu + 2)(2\mu - 1) = 0$$

$$\therefore \mu = \frac{1}{2} \text{ [as } \mu \neq -2]$$

8. Answer (A, B)

$$U = -\frac{ke^2}{4r^4}$$

$$\text{Force } F = -\frac{dU}{dr} = +\frac{ke^2}{4r^5}(-4) = \frac{-ke^2}{r^5}$$

According to Bohr theory

$$\text{Centripetal force } \frac{ke^2}{r^5} = \frac{mv^2}{r} \quad \dots(i)$$

$$\text{Also } mvr = \frac{nh}{2\pi}$$

$$\Rightarrow v = \frac{nh}{2\pi m r}$$

Substituting v in (i) we get

$$\frac{ke^2}{r^5} = \frac{m}{r} \frac{n^2 h^2}{4\pi^2 r^2 m^2}$$

$$r^2 = \frac{ke^2 4\pi^2 m}{n^2 h^2} = \frac{1}{4\pi\epsilon_0} \frac{e^2 4\pi^2 m}{n^2 h^2}$$

$$r = \left(\frac{\pi e^2 m}{\epsilon_0 n^2 h^2} \right)^{1/2} = \frac{e}{nh} \sqrt{\frac{\pi m}{\epsilon_0}}$$

$$\text{Now } v = \frac{nh}{2\pi m r}$$

$$= \frac{nh}{2\pi m \frac{e}{nh} \sqrt{\frac{\pi m}{\epsilon_0}}}$$

$$= \frac{n^2 h^2}{2\pi m e} \sqrt{\frac{\epsilon_0}{\pi m}}$$

$$\text{KE} = \frac{1}{2} m v^2 = \frac{1}{2} m \frac{n^4 h^4}{4\pi^2 m^2 e^2} \frac{\epsilon_0}{\pi m}$$

$$= \frac{n^4 h^4 \epsilon_0}{8\pi^3 m^2 e^2}$$

$$\text{PE} = -\frac{ke^2}{4r^4} = -\frac{1}{4\pi\epsilon_0} \frac{e^2}{4 \frac{e^4}{n^4 h^4} \frac{\pi^2 m^2}{\epsilon_0^2}}$$

$$= -\frac{n^4 h^4 \epsilon_0}{16\pi^3 m^2 e^2}$$

$$\text{TE} = \text{KE} + \text{PE}$$

$$= \frac{n^4 h^4 \epsilon_0}{\pi^3 m^2 e^2} \left\{ \frac{1}{8} - \frac{1}{16} \right\}$$

$$= n^4 \pi \left(\frac{h^4}{16\pi^4} \right) \frac{\epsilon_0}{m^2 e^2}$$

$$= n^4 h^4 \frac{\pi \epsilon_0}{m^2 e^2}$$

9. Answer (A, C)

$$dN = -N\lambda dt + R dt$$

$$\int_{N_0}^N dN = -\int_0^t \left(N - \frac{R}{\lambda} \right) \lambda dt$$

$$\left(N - \frac{R}{\lambda} \right)_{N_0 - \frac{R}{\lambda}} = e^{-\lambda t}$$

$$N - \frac{R}{\lambda} = \left(N_0 - \frac{R}{\lambda} \right) e^{-\lambda t}$$

$$t \rightarrow \infty$$

$$N = \frac{R}{\lambda} \text{ irrespective of value of } N_0$$



10. Answer (A, B)

The tendency of bouncing of cylinder will be maximum when P is at the highest point of cylinder during rolling motion.

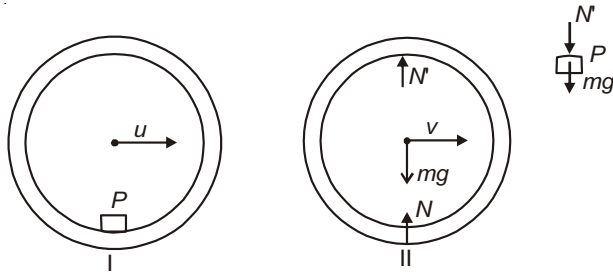

Law of conservation of energy

$$\frac{1}{2}mu^2 + \frac{1}{2}(mR^2)\left(\frac{u}{R}\right)^2 - mgR = \frac{1}{2}m(2v)^2 + \frac{1}{2}mv^2 + \frac{1}{2}(mR^2)\left(\frac{v}{R}\right)^2 + mgR$$

$$mu^2 = 3mv^2 + 2mgR$$

$$\Rightarrow 3v^2 = u^2 - 2gR$$

Now at final position

$$N' + mg = \frac{mv^2}{R} \text{ (for body } P\text{)}$$

Also $N + N' = mg$ (for cylinder)

$$\Rightarrow 2mg - \frac{mv^2}{R} = N$$

If cylinder does not bounce

$$N \geq 0 \Rightarrow 2g \geq \frac{v^2}{R}$$

$$v \leq \sqrt{2gR} \quad \frac{u^2 - 2gR}{3} \leq 2gR$$

$$\text{or } u \leq \sqrt{8gR}$$

11. Answer (A, B, C, D)

In equilibrium position net force on partition will be zero. Hence pressure on both side are same

$$PV = nRT$$

$$n_1 = \frac{PV}{RT}$$

$$n_2 = \frac{(2P)(2V)}{RT} = \frac{4PV}{RT} \Rightarrow n_2 = 4n_1$$

moles remain conserved.

at equilibrium, $P_1V_1 = n_1RT_1$ & $P_2V_2 = n_2RT_2$

$$P_1 = P_2 \text{ and } T_1 = T_2$$

$$\frac{V_1}{V_2} = \frac{n_1}{n_2} = \frac{1}{4} \quad V_2 = 4V_1 \text{ and } V_1 + V_2 = 3V$$

$$\Rightarrow V_1 = \frac{3}{5}V$$

$$V_2 = \frac{12}{5}V$$

Hence (B), (C) are correct.

12. Answer (B, D)

$$\frac{P^2}{\rho} = \text{constant} \quad \frac{P^2RT}{PM} = \text{constant}$$

$$PT = \text{constant}$$

$$\frac{P^2}{\rho} = \frac{P'^2}{\rho/2} \Rightarrow P' = \frac{P}{\sqrt{2}}$$

$$\text{also } T' = T\sqrt{2}$$

$$PT = \text{constant.}$$

$\therefore P-T$ curve is a rectangular hyperbola.

13. Answer (B, D)

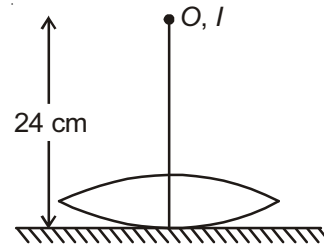

Let F_1 be equivalent focal length of the lens mirror combination

$$\therefore 2F_1 = 24 \text{ cm}$$

$$F_1 = 12 \text{ cm}$$

$$\Rightarrow \frac{1}{F_1} = \frac{2}{f_l} + \frac{1}{\infty}$$

$$f_l = 24 \text{ cm} = \text{focal length of lens.}$$

When filled with water combination of glass lens, water lens and a plane mirror

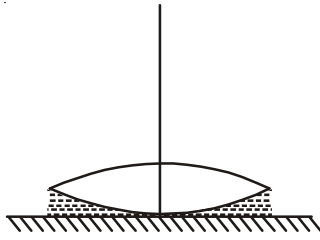

F_2 = equivalent focal length of new combination

$$\frac{1}{F_2} = \frac{-2}{f_1} + \frac{-2}{f_w} + \frac{1}{\infty}$$

$$\frac{1}{F_2} = \frac{-2}{f_1} + \frac{-2}{f_w} \quad \dots(i)$$

Applying lens maker formula on glass lens and water lens

$$\frac{1}{f_1} = (15 - 1) \left(\frac{1}{x} - \frac{1}{-x} \right)$$

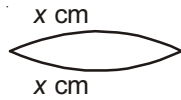

$$x = 24 \text{ cm}$$

$$\frac{1}{f_w} = \left(\frac{4}{3} - 1 \right) \left(\frac{1}{-x} - \frac{1}{\infty} \right)$$

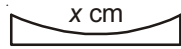

$$f_w = -72 \text{ cm}$$

Substituting in (i) we get

$$\frac{1}{F_2} = \frac{-2}{24} + \frac{-2}{-72}$$

$$F_2 = -18 \text{ cm}$$

$$2F_2 = -36 \text{ cm}$$

Shift = (36 - 24) = 12 cm upward.

14. Answer (A, B, C)

$$KE_f = 4 KE_i$$

$$\Rightarrow v_f = 2 v_i$$

$$v_i = \omega \sqrt{A^2 - \left(\frac{A}{2}\right)^2}$$

$$v_f = \omega \sqrt{A^2 - \left(\frac{A}{2}\right)^2} \Rightarrow v_i = \frac{\omega\sqrt{3}}{2} A$$

By applying conservation of energy after impulse

$$\frac{1}{2} m v_f^2 + \frac{1}{2} k \left[\frac{A}{2} \right]^2 = \frac{1}{2} k A_f^2 \Rightarrow A_f = \frac{\sqrt{13}}{2} A$$

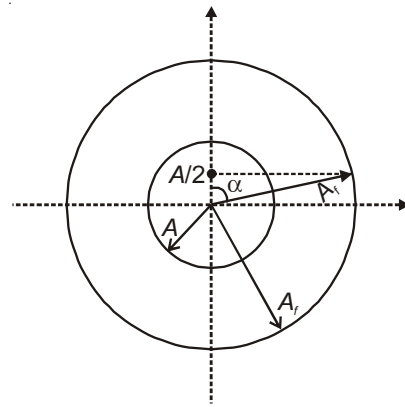

Minimum time taken by particle to cross the same position again

$$\cos \alpha = \frac{A/2}{A} = \frac{1}{\sqrt{13}}$$

$$\alpha = \cos^{-1} \frac{1}{\sqrt{13}}$$

$$2\alpha = \omega t_{\min} \Rightarrow t_{\min} = \frac{2 \cos^{-1} \frac{1}{\sqrt{13}}}{\omega}$$

15. Answer (C)

16. Answer (B)

Point A will undergo circular motion about X

$$\text{Torque about COM} = (T \sin 45^\circ) \frac{l}{2} = \frac{ml^2}{12} \alpha$$

COM acceleration

$$a_x = \frac{T \cos 45^\circ}{m}$$

$$a_y = \frac{mg - T \sin 45^\circ}{m}$$

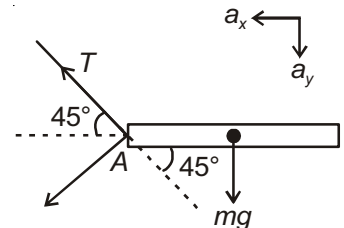

Immediately after cutting of string, the speed of point A is zero, hence its centripetal acceleration towards point X must be zero.

$$a_x \cos 45^\circ - a_y \cos 45^\circ + \alpha \frac{l}{2} \cos 45^\circ = 0$$

$$2(a_x - a_y) + \alpha l = 0$$

$$2 \left\{ \frac{T}{\sqrt{2}m} - g + \frac{T}{\sqrt{2}m} \right\} + \frac{6T}{\sqrt{2}m} = 0$$

$$\left(\frac{2T}{m} - g + \frac{3T}{m} \right) = 0$$

$$T = \frac{mg}{5}$$

17. Answer (C)

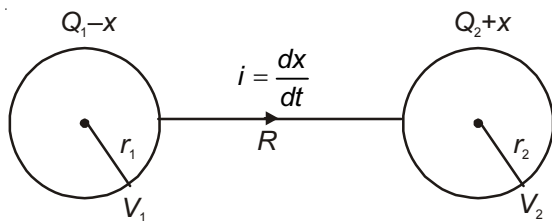

Applying KVL

$$V_1 - \left(\frac{dx}{dt}\right)R = V_2$$

$$\frac{k(Q_1 - x)}{r_1} - \frac{dx}{dt}R = k \frac{(Q_2 + x)}{r_2} \quad \text{where } k = \frac{1}{4\pi\epsilon_0}$$

$$R \frac{dx}{dt} = \frac{kQ_1}{r_1} - \frac{kQ_2}{r_2} - k \left(\frac{1}{r_1} + \frac{1}{r_2}\right)x$$

$$R \int_0^x \frac{dx}{k \left(\frac{Q_1}{r_1} - \frac{Q_2}{r_2}\right) - k \left(\frac{1}{r_1} + \frac{1}{r_2}\right)x} = \int_0^t dt$$

$$\frac{R}{-k \left(\frac{1}{r_1} + \frac{1}{r_2}\right)} \ln \left[\frac{k \left(\frac{Q_1}{r_1} - \frac{Q_2}{r_2}\right) - k \left(\frac{1}{r_1} + \frac{1}{r_2}\right)x}{k \left(\frac{Q_1}{r_1} - \frac{Q_2}{r_2}\right)} \right] = t$$

$$1 - \frac{\left(\frac{1}{r_1} + \frac{1}{r_2}\right)x}{\frac{Q_1}{r_1} - \frac{Q_2}{r_2}} = e^{-\frac{tk \left(\frac{1}{r_1} + \frac{1}{r_2}\right)x}{R}}$$

$$\text{or } x = \frac{\frac{Q_1}{r_1} - \frac{Q_2}{r_2}}{\frac{1}{r_1} + \frac{1}{r_2}} \left\{ 1 - e^{-\frac{tk \left(\frac{1}{r_1} + \frac{1}{r_2}\right)x}{R}} \right\}$$

18. Answer (A)

$$H = \frac{C_1 C_2}{2(C_1 + C_2)} |V_1 - V_2|^2 \quad C_1 = 4\pi\epsilon_0 r_1$$

$$C_2 = 4\pi\epsilon_0 r_2$$

$$V_1 = \frac{Q_1}{4\pi\epsilon_0 r_1}$$

$$V_2 = \frac{Q_2}{4\pi\epsilon_0 r_2}$$

$$\therefore H = \frac{r_1 r_2}{8\pi\epsilon_0 (r_1 + r_2)} \left(\frac{Q_1}{r_1} - \frac{Q_2}{r_2}\right)^2$$

PART - II (CHEMISTRY)

19. Answer (B)

CCP refers to FCC crystal structure.

X-X bond length = 160 pm

For FCC $a\sqrt{2} = 4r$

$$a \text{ (edge length)} = \frac{4r}{\sqrt{2}} = 160\sqrt{2} = 226$$

Volume of unit cell = $a^3 = (226 \times 10^{-10})^3$

Number of atoms in FCC = 4

$$\text{Number of atoms in } 1 \text{ cm}^3 = \frac{4}{(226 \times 10^{-10})^3}$$

$$= 3.45 \times 10^{23}$$

20. Answer (B)

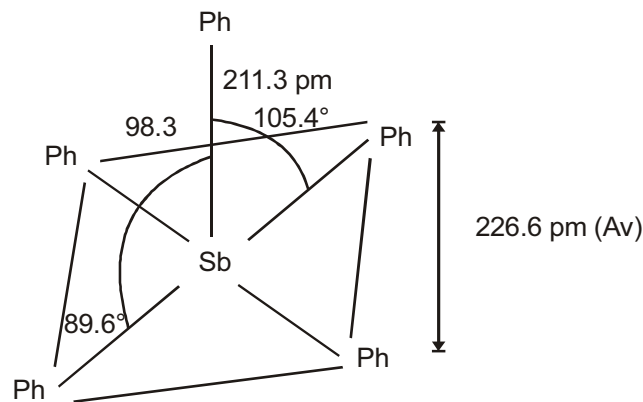
→ Sb(Ph)₅ - Slightly distorted square pyramidal→ P(Ph)₅ Trigonal bipyramidal

21. Answer (B)

$$\begin{aligned} K &= (k_1)^2 \cdot (k_2)^3 \\ &= (0.05)^2 \cdot (2 \times 10^{-12})^3 \\ &= 2 \times 10^{-38} \end{aligned}$$

22. Answer (A)

Rate of destruction of O_3 must equal to rate of formation



$$\text{Rate of destruction of } O_3 = \frac{-\Delta[O_3]}{\Delta t} = K[O_3]^2$$

$$K = \frac{-\Delta[O_3]}{\Delta t} \times \frac{1}{[O_3]^2}$$

$$= \frac{8.2 \times 10^{-15} \text{ mol L}^{-1} \text{ h}^{-1}}{3600 \text{ s} \cdot \text{h}^{-1}} \times \frac{1}{(4.0 \times 10^{-8} \text{ mol L}^{-1})^2}$$

$$= 1.42 \times 10^{-3}$$

23. Answer (D)

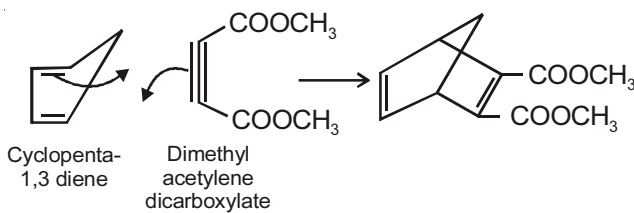

24. Answer (B)

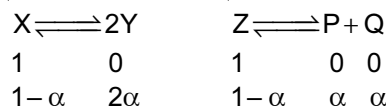

$$K_{P1} = \frac{P_y^2}{P_x} = \frac{\left(\frac{2\alpha}{1+\alpha} \cdot P_1\right)^2}{\left(\frac{1-\alpha}{1+\alpha} \cdot P_1\right)} = \frac{4\alpha^2 P_1}{1-\alpha^2}$$

Also

$$K_{P2} = \frac{P_p \cdot P_q}{P_z} = \frac{\left(\frac{\alpha}{1+\alpha} \cdot P_2\right) \left(\frac{\alpha}{1+\alpha} \cdot P_2\right)}{\left(\frac{1-\alpha}{1+\alpha} \cdot P_2\right)} = \frac{\alpha^2 P_2}{1-\alpha^2}$$

$$\frac{K_{P1}}{K_{P2}} = \frac{1}{9} \Rightarrow \frac{4\alpha^2 P_1}{\alpha^2 P_2} = \frac{1}{9}$$

$$\therefore \frac{P_1}{P_2} = \frac{1}{36}$$

$$P_1 : P_2 = 1 : 36$$

25. Answer (C)

26. Answer (A, C, D)

27. Answer (A, B, C)

$Cu^{2+} > Cu^+$ stable due to higher hydration energy.

Cu^{2+} paramagnetic $-4s^0 3d^9$ (unpaired electron) and coloured.

28. Answer (A, C, D)

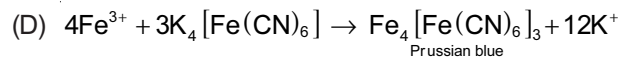
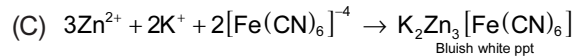
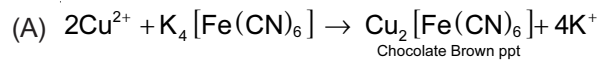

29. Answer (A, B, C, D)

(A) Is correct—lattice and hydration energy decrease down the group

(B) Is correct — BeF_2 having high hydration energy

(D) Also is correct — $BeSO_4$ is soluble due to high hydration energy.

30. Answer (A, B, D)

31. Answer (A, C)

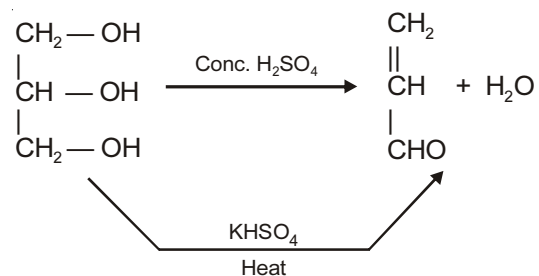

(D) Not possible

32. Answer (B, C, D)

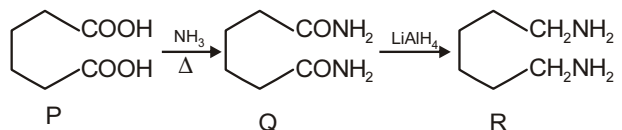
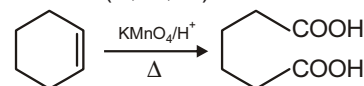

Adipic acid

Now, P and R react

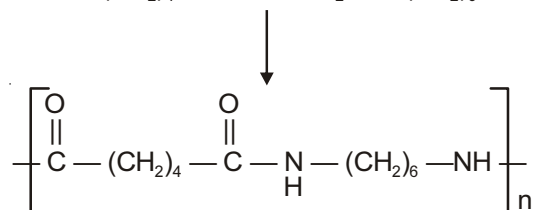

Nylon-66



33. Answer (C)

34. Answer (C)

35. Answer (C)

At point 3, both species will remain.

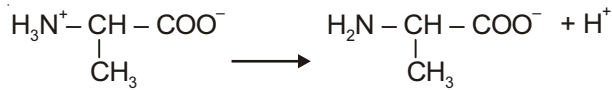

$$[\text{H}^+] \text{ At point 3} = K_2 = 2 \times 10^{-10}$$

$$\text{pH} = \text{p}K_a$$

$$\text{pH} = 10 - \log 2 \quad (\because \log 2 = 0.3010)$$

$$\text{pH} = 9.7$$

36. Answer (D)

PART - III (MATHEMATICS)

37. Answer (C)

$$\begin{aligned} \sigma(n) &= \sum_{r=1}^n \{r^2 ({}^n C_r - {}^n C_{r-1}) + 2r {}^n C_r + {}^n C_r\} \\ &= \sum_{r=1}^n \{(r^2 + 2r + 1) {}^n C_r - r^2 \cdot {}^n C_{r-1}\} \\ &= \sum_{r=1}^n \{(r+1)^2 {}^n C_r - r^2 \cdot {}^n C_{r-1}\} \\ &= \sum_{r=1}^n (V_{r+1} - V_r) \\ &= (V_2 - V_1) + (V_3 - V_2) + \dots + (V_{n+1} - V_n) \\ &= V_{n+1} - V_1 \\ &= (n+1)^2 {}^n C_n - 1 = n^2 + 2n \end{aligned}$$

$$\text{so, } \sigma(50) = 2600$$

38. Answer (D)

(5, 15) lies inside the circle and (5, 15) should be the mid-point of the chord.

$$\therefore \frac{-p}{q} = -1 \quad \Rightarrow \quad p = q$$

$$\text{Now, } 5p + 15q = 40 \quad \Rightarrow \quad p + 3q = 8 \quad \Rightarrow \quad p = q = 2$$

39. Answer (A)

Equation of plane through first two planes is

$$2x + y + z - 1 + \lambda(3x + y + 2z - 2) = 0$$

If it is parallel to second line, then

$$(2 + 3\lambda)1 + (1 + \lambda)1 + (1 + 2\lambda) \cdot 1 = 0$$

$$\Rightarrow \lambda = \frac{-2}{3}$$

$$\therefore \text{Equation of the plane is } y - z + 1 = 0$$

$$\text{Distance from } (0, 0, 0) = \frac{1}{\sqrt{2}}$$

40. Answer (A)

$$I = \int \frac{x^6 - x^4 + x^2 - 1}{x^{10} + 1} x \, dx$$

$$\text{Let } x^2 = t$$

$$\therefore 2x \, dx = dt$$

$$I = \frac{1}{2} \int \frac{t^3 - t^2 + t - 1}{t^5 + 1} dt$$

$$= \frac{1}{2} \int \frac{(t^2 + 1)(t - 1)}{t^5 + 1} dt$$

$$= \frac{1}{2} \int \frac{t^4 - 1}{(t^5 + 1)(t + 1)} dt$$

$$= \frac{1}{2} \int \left(\frac{t^4}{t^5 + 1} - \frac{1}{t + 1} \right) dt$$

$$= \frac{1}{2} \left[\frac{1}{5} \ln(t^5 + 1) - \ln(t + 1) \right] + C$$

$$= \frac{1}{2} \left[\frac{1}{5} \ln(t^5 + 1) - \frac{1}{5} \ln(t + 1)^5 \right] + C$$

$$= \frac{1}{10} \ln \left(\frac{x^{10} + 1}{(x^2 + 1)^5} \right) + C$$

41. Answer (B)

$$f(x) = [x] (x^2 - 25)^n (x^2 + 3)^m (x^2 + 3x + 4)^{3m}$$

$$f(5) = 0, f(5^-) = 4 (\text{negative})^n (+) (+)$$

$$\text{For a local minima at } x = 5, f(5^-) > 0$$

$$\text{For this } n \text{ must be even, } m \in R$$

42. Answer (A)

$$f(x) = x\{x\} - x[-x]$$

$$= \begin{cases} x^2, & x \in I \\ x^2 + x, & x \notin I \end{cases}$$

The integers not belonging to the range of $f(x)$ are 1, 2, 2-3, 3-4 i.e., 2, 6, 12.

$$\text{Further } x^2 + x \geq -\frac{1}{4} \text{ so } \{-15, -14, \dots, -1\} \notin R_f.$$

$$\text{So required number of elements} = 3 + 15 = 18.$$

43. Answer (C)

$$f(-5) = 2, f(20) = f(4) = 3, f(17) = -2$$

$$\therefore k = 2 + 3 - 2 = 3$$

$$\text{Now } g(x) = x^3 + |\sin x|$$

$$\lim_{x \rightarrow -\infty} g(x) = -\infty \text{ and } \lim_{x \rightarrow +\infty} g(x) = \infty$$

$g(0) = 0$, $g(x)$ is neither increasing nor decreasing on R

$\therefore g(x)$ is many-one and onto.

44. Answer (B, C, D)

$$\sqrt{3} \sin C = \frac{2}{\cos A} - \frac{\sin A}{\cos A}$$

$$\Rightarrow \sqrt{3} \sin C \cos A = 2 - \sin A$$

$$\Rightarrow \sqrt{3} \sin C \cdot \cos A > 0, \text{ as } 2 - \sin A > 0$$

$\Rightarrow A$ is an acute angle.

Now, $\sin C \leq 1$

$$\therefore \sqrt{3} \sin C \cdot \cos A \leq \sqrt{3} \cos A$$

$$\Rightarrow 2 - \sin A \leq \sqrt{3} \cos A$$

$$\Rightarrow \sqrt{3} \cos A + \sin A \geq 2$$

But, $\sqrt{3} \cos A + \sin A \leq 2$

$$\Rightarrow \sqrt{3} \cos A + \sin A = 2$$

$$\Rightarrow 2 \sin\left(\frac{\pi}{3} + A\right) = 2$$

$$\Rightarrow \sin\left(\frac{\pi}{3} + A\right) = \sin \frac{\pi}{2}$$

$$\Rightarrow \frac{\pi}{3} + A = \frac{\pi}{2}$$

$$\Rightarrow \boxed{A = \frac{\pi}{6}}$$

$$\therefore \sqrt{3} \sin C \cos \frac{\pi}{6} = 2 - \sin \frac{\pi}{6}$$

$$\Rightarrow \frac{3}{2} \sin C = \frac{3}{2}$$

$$\Rightarrow \sin C = 1 \Rightarrow \boxed{C = \frac{\pi}{2}}$$

$$\therefore \boxed{B = \frac{\pi}{3}}$$

Consequently $c = 4$

$$\text{Now, } \frac{a}{\sin A} = \frac{b}{\sin B} = \frac{c}{\sin C}$$

$$\Rightarrow \frac{a}{\frac{1}{2}} = \frac{b}{\frac{\sqrt{3}}{2}} = \frac{c}{1} = \frac{a+b+c}{\frac{1}{2} + \frac{\sqrt{3}}{2} + 1}$$

$$\Rightarrow 4 = \frac{2s}{\left(\frac{1+\sqrt{3}+2}{2}\right)} \Rightarrow 2s = 4 \left(\frac{3+\sqrt{3}}{2}\right)$$

$$\Rightarrow s = 3 + \sqrt{3}$$

$$\text{Also, } a = 4 \cdot \frac{1}{2} = 2, b = 4 \cdot \frac{\sqrt{3}}{2} = 2\sqrt{3}$$

$$\therefore \Delta = \frac{1}{2} ab = \frac{1}{2} \cdot 2 \cdot 2\sqrt{3} = 2\sqrt{3}$$

$$r = \frac{\Delta}{S} = \frac{2\sqrt{3}}{3+\sqrt{3}} = \frac{2}{1+\sqrt{3}} \times \frac{\sqrt{3}-1}{\sqrt{3}-1} = \frac{2(\sqrt{3}-1)}{2}$$

$$R = \frac{c}{2 \sin C} = \frac{4}{2} = 2$$

45. Answer (C, D)

$$f(x)f'(x) \geq x(f(x))^2 \sqrt{(f(x))^4 - 1}$$

$$\Rightarrow \frac{2f(x)f'(x)}{(f(x))^2 \sqrt{(f(x))^4 - 1}} \geq 2x$$

$$\Rightarrow \frac{d}{dx} (\sec^{-1}(f(x))^2 - x^2) \geq 0$$

$\therefore g(x) = \sec^{-1}(f(x))^2 - x^2$ is a non-decreasing function.

$$\Rightarrow \lim_{x \rightarrow m^+} g(x) \leq \lim_{x \rightarrow n^-} g(x)$$

$$\Rightarrow 0 - m^2 \leq \frac{\pi}{3} - n^2$$

$$\Rightarrow n^2 - m^2 \leq \frac{\pi}{3}$$

46. Answer (D)

It is given that $a_i + i = S - a_i$

Putting $i = 1, 2, 3, \dots, 100$ and adding

$$2S + \frac{100 \times 101}{2} = 100S$$

$$\Rightarrow S = \frac{25 \times 101}{49} \Rightarrow 49S = 25 \times 101$$

47. Answer (C, D)

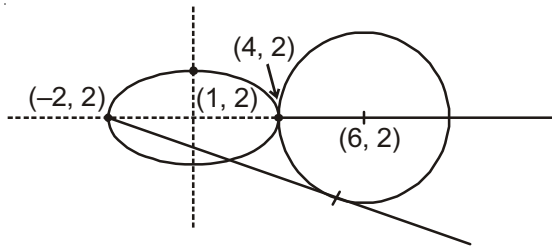

m and n are the powers of the points lying on the ellipse
 $\frac{(x-1)^2}{9} + \frac{(y-2)^2}{4} = 1$ w.r.t. the circle $x^2 + y^2 - 12x - 4y + 36 = 0$

Clearly, $m = 60, n = 0$

48. Answer (A, B, C)

If $p(k)$ denote the probability of getting a score k , then

$$p(1) = P(T) = \frac{1}{2}, p(2) = P(TT \text{ or } H) = \frac{1}{4} + \frac{1}{2} = \frac{3}{4}$$

A score of k can be obtained either by

- (i) Throwing a tail, when the score is $k-1$ or
- (ii) By throwing a head when the score is $k-2$

$$\begin{aligned} \text{Now, } P(k) &= \frac{1}{2}P(k-1) + \frac{1}{2}P(k-2) \\ &= \frac{1}{2}[P(k-1) + P(k-2)] \end{aligned}$$

$$\text{So, } p = P(7) = \frac{85}{128} \sim 0.66406$$

49. Answer (B, D)

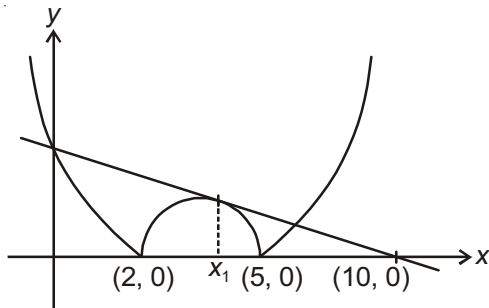

For 3 distinct real solutions, $y = m(x-10)$ will be a tangent to $y = -x^2 + 7x - 10$ and $2 < x_1 < 5$

$$\begin{aligned} \Rightarrow \text{Discriminant of } \{x^2 - (m-7)x + (10-10m) = 0\} &= 0 \\ \Rightarrow (m-7)^2 - 4(10-10m) &= 0 \\ \Rightarrow m^2 + 26m + 9 &= 0 \\ \Rightarrow m &= -13 \pm 4\sqrt{10} \end{aligned}$$

$$\text{and } 2 < \frac{7-m}{2} < 5 \Rightarrow m \in (-3, 3)$$

50. Answer (B, C, D)

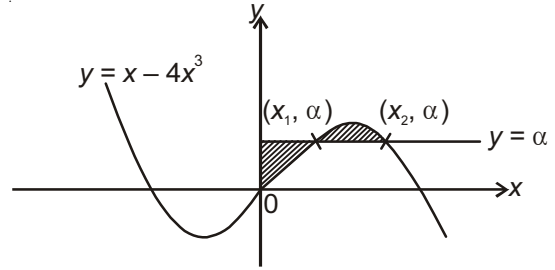

$$\text{Given that } \int_0^{x_2} (x - 4x^3) dx = \int_0^{x_2} \alpha \cdot dx$$

$$\Rightarrow \left(\frac{x^2}{2} - x^4 \right)_0^{x_2} = \alpha x_2$$

$$\Rightarrow \frac{x_2^2}{2} - x_2^4 = \alpha x_2$$

$$\Rightarrow \frac{x_2}{2} - x_2^3 = \alpha, \text{ also } \boxed{\alpha = x_2 - 4x_2^3}$$

$$\Rightarrow \frac{x_2}{2} - x_2^3 = x_2 - 4x_2^3$$

$$\Rightarrow 3x_2^3 = \frac{x_2}{2}$$

$$\Rightarrow 6x_2^3 - x_2 = 0$$

$$\Rightarrow x_2(6x_2^2 - 1) = 0 \Rightarrow \boxed{x_2 = \frac{1}{\sqrt{6}}}$$

$$\therefore \alpha = \frac{1}{\sqrt{6}} - \frac{4}{6\sqrt{6}}$$

$$= \frac{1}{\sqrt{6}} \left(1 - \frac{2}{3} \right)$$

$$\boxed{\alpha = \frac{1}{3\sqrt{6}}}$$

51. Answer (D)

As E and H are orthogonal.

\therefore They are confocal.

\therefore Coordinates of the foci are $(\pm ae, 0) = (\pm 1, 0)$

Eccentricity e of $E = \frac{1}{\sqrt{2}}; p = \sqrt{2}, q = 1$

\therefore Equation of ellipse E is $\frac{x^2}{2} + \frac{y^2}{1} = 1$

52. Answer (C)

The point must lie on the director circle of E i.e., $x^2 + y^2 = 3$

Solutions of Q.Nos 53 and 54

$$\text{As } z_1^3 + z_2^3 + z_3^3 + z_1 z_2 z_3 = 0$$

$$\Rightarrow (z_1 + z_2 + z_3)\{(z_1 + z_2 + z_3)^2 - 3z_1 z_2 - 3z_2 z_3 - 3z_3 z_1\} = -4z_1 z_2 z_3$$

$$\Rightarrow (z_1 + z_2 + z_3)^3 - 3((z_1 + z_2 + z_3)(z_1 z_2 + z_2 z_3 + z_3 z_1) + 4z_1 z_2 z_3) = 0$$

$$\Rightarrow (z_1 + z_2 + z_3)^3 - z_1 z_2 z_3$$

$$\left\{ 3(z_1 + z_2 + z_3) \left(\frac{1}{z_3} + \frac{1}{z_2} + \frac{1}{z_1} \right) - 4 \right\} = 0$$

$$\Rightarrow (z_1 + z_2 + z_3)^3 = z_1 z_2 z_3$$

$$\left\{ 3(z_1 + z_2 + z_3)(\bar{z}_3 + \bar{z}_2 + \bar{z}_1) - 4 \right\}$$

$$\Rightarrow |z_1 + z_2 + z_3|^3 = 1 |3(z_1 + z_2 + z_3)(\overline{z_1 + z_2 + z_3}) - 4|$$

$$\text{Let } |z_1 + z_2 + z_3| = m, \text{ then}$$

$$m^3 = |3m^2 - 4| \Rightarrow m = 1, 2$$

53. Answer (D)

$$\text{Sum of all the integral values of } |z_1 + z_2 + z_3| = 1+2=3$$

54. Answer (B)

$$\text{Given that, } |z_1 + z_2 + z_3| = 2$$

$$\text{Now, } |z_1 + z_2 + z_3|^2 = 4$$

$$\Rightarrow (z_1 + z_2 + z_3)(\bar{z}_1 + \bar{z}_2 + \bar{z}_3) = 4$$

$$\Rightarrow 3 + z_1 \bar{z}_2 + z_1 \bar{z}_3 + z_2 \bar{z}_1 + z_2 \bar{z}_3 + z_3 \bar{z}_1 + z_3 \bar{z}_2 = 4$$

$$\Rightarrow (z_1 \bar{z}_2 + z_2 \bar{z}_1) + (z_1 \bar{z}_3 + z_3 \bar{z}_1) + (z_2 \bar{z}_3 + z_3 \bar{z}_2) = 1$$

$$\Rightarrow 2\{\text{Re}(z_1 \bar{z}_2) + \text{Re}(z_3 \bar{z}_1) + \text{Re}(z_2 \bar{z}_3)\} = 1$$

$$\Rightarrow \text{Re}(z_1 \bar{z}_2 + z_1 \bar{z}_3 + z_2 \bar{z}_3) = \frac{1}{2}$$