

DATE : 20/05/2018



Aakash

Medical | IIT-JEE | Foundations

(Divisions of Aakash Educational Services Pvt. Ltd.)

Regd. Office : Aakash Tower, 8, Pusa Road, New Delhi-110005

Ph.: 011-47623456 Fax : 011-47623472

Time : 3 hrs.

Answers & Solutions

Max. Marks: 180

for

JEE (Advanced)-2018

PAPER - 2

PART-I : PHYSICS

SECTION - 1 (Maximum Marks : 24)

- This section contains **SIX (06)** questions.
- Each question has **FOUR** options for correct answer(s). **ONE OR MORE THAN ONE** of these four option(s) is (are) correct option(s).
- For each question, choose the correct option(s) to answer the question.
- Answer to each question will be evaluated according to the following marking scheme:

Full Marks : +4 If only (all) the correct option(s) is (are) chosen.

Partial Marks : +3 If all the four options are correct but **ONLY** three options are chosen.

Partial Marks : +2 If three or more options are correct but **ONLY** two options are chosen, both of which are correct options.

Partial Marks : +1 If two or more options are correct but **ONLY** one option is chosen and it is a correct option.

Zero Marks : 0 If none of the options is chosen (i.e. the question is unanswered).

Negative Marks : -2 In all other cases.

For Example: If first, third and fourth are the **ONLY** three correct options for a question with second option being an incorrect option; selecting only all the three correct options will result in +4 marks. Selecting only two of the three correct options (e.g. the first and fourth options), without selecting any incorrect option (second option in this case), will result in +2 marks. Selecting only one of the three correct options (either first or third or fourth option), without selecting any incorrect option (second option in this case), will result in +1 marks. Selecting any incorrect option(s) (second option in this case), with or without selection of any correct option(s) will result in -2 marks.

1. A particle of mass m is initially at rest at the origin. It is subjected to a force and starts moving along the x -axis. Its kinetic energy K changes with time as $dK/dt = \gamma t$, where γ is a positive constant of appropriate dimensions. Which of the following statements is (are) true?

- (A) The force applied on the particle is constant
- (B) The speed of the particle is proportional to time
- (C) The distance of the particle from the origin increases linearly with time
- (D) The force is conservative

Answer (A, B, D)

Sol. $K = \frac{1}{2}mv^2 \Rightarrow \frac{dK}{dt} = mv \frac{dv}{dt} = \gamma t$

given, $\frac{dK}{dt} = \gamma t \Rightarrow mv \frac{dv}{dt} = \gamma t$

$\Rightarrow \int_0^v v dv = \int_0^t \frac{\gamma}{m} t dt \Rightarrow \frac{v^2}{2} = \frac{\gamma}{m} \frac{t^2}{2}$

$\Rightarrow v = \sqrt{\frac{\gamma}{m} t} \Rightarrow a = \frac{dv}{dt} = \sqrt{\frac{\gamma}{m}}$

$F = ma = \sqrt{\gamma m} = \text{constant}$

$\frac{dS}{dt} = \sqrt{\frac{\gamma}{m} t} \Rightarrow S = \sqrt{\frac{\gamma}{m}} \frac{t^2}{2}$

2. Consider a thin square plate floating on a viscous liquid in a large tank. The height h of the liquid in the tank is much less than the width of the tank. The floating plate is pulled horizontally with a constant velocity u_0 . Which of the following statements is (are) true?

- (A) The resistive force of liquid on the plate is inversely proportional to h
- (B) The resistive force of liquid on the plate is independent of the area of the plate
- (C) The tangential (shear) stress on the floor of the tank increases with u_0
- (D) The tangential (shear) stress on the plate varies linearly with the viscosity η of the liquid

Answer (A, C, D)

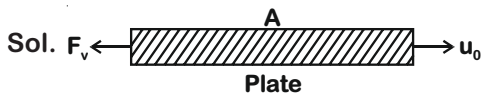

$F_v = \eta A \left(\frac{dv}{dz} \right)$

Since height h of the liquid in tank is very small $\Rightarrow \frac{dv}{dz} = \frac{\Delta v}{\Delta z} = \left(\frac{u_0}{h} \right)$

$F_v = (\eta) A \left(\frac{u_0}{h} \right)$

$F_v \propto \left(\frac{1}{h} \right), F_v \propto u_0, F_v \propto A, F_v \propto \eta$

3. An infinitely long thin non-conducting wire is parallel to the z-axis and carries a uniform line charge density λ . It pierces a thin non-conducting spherical shell of radius R in such a way that the arc PQ subtends an angle 120° at the centre O of the spherical shell, as shown in the figure. The permittivity of free space is ϵ_0 . Which of the following statements is (are) true?

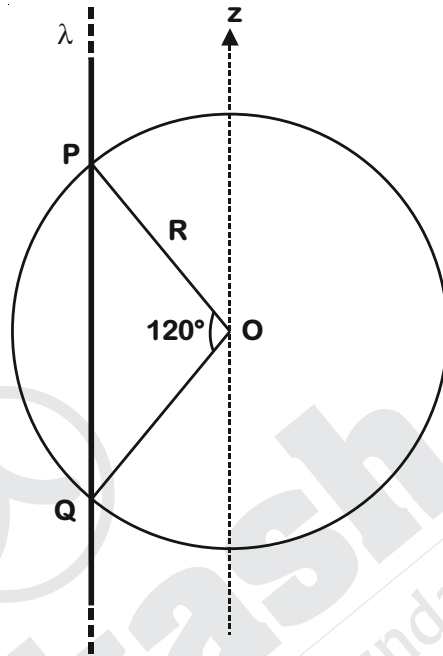

- (A) The electric flux through the shell is $\frac{\sqrt{3}R\lambda}{\epsilon_0}$
- (B) The z-component of the electric field is zero at all the points on the surface of the shell
- (C) The electric flux through the shell is $\frac{\sqrt{2}R\lambda}{\epsilon_0}$
- (D) The electric field is normal to the surface of the shell at all points

Answer (A, B)

Sol. $PQ = (2) R \sin 60^\circ$

$$= (2R) \frac{\sqrt{3}}{2} = (\sqrt{3}R)$$

$$Q_{\text{enclosed}} = \lambda(\sqrt{3}R)$$

$$\text{We have } \phi = \frac{q_{\text{enclosed}}}{\epsilon_0}$$

$$\Rightarrow \phi = \left(\frac{\sqrt{3}\lambda R}{\epsilon_0} \right)$$

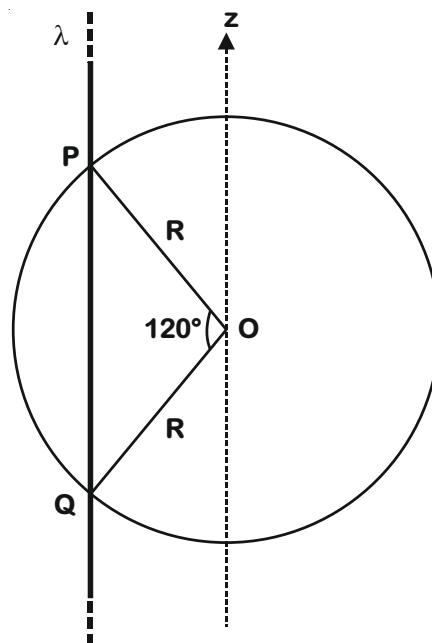

Also electric field is perpendicular to wire so Z-component will be zero.

4. A wire is bent in the shape of a right angled triangle and is placed in front of a concave mirror of focal length f , as shown in the figure. Which of the figures shown in the four options qualitatively represent (s) the shape of the image of the bent wire? (These figures are not to scale).

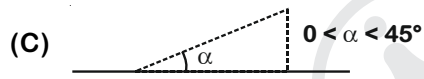
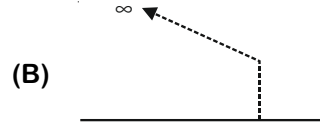
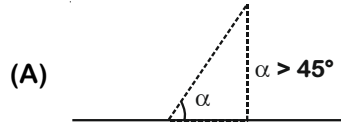
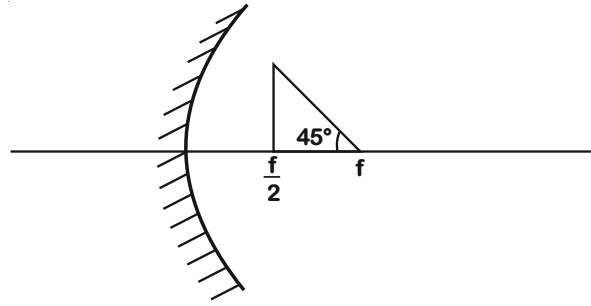

Answer (D)

Sol. Image of point A

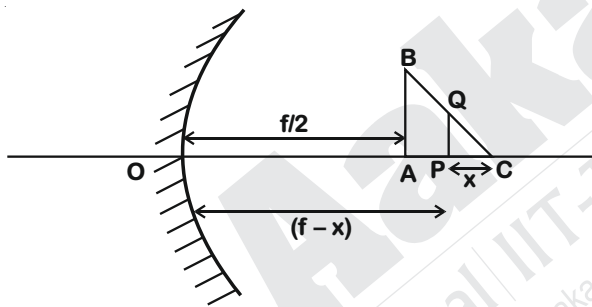

$$\frac{1}{v} + \frac{1}{-\left(\frac{f}{2}\right)} = \frac{1}{-f} \Rightarrow v = f$$

$$\Rightarrow \frac{l_{AB}}{AB} = -\frac{f}{-\frac{f}{2}} \Rightarrow l_{AB} = 2AB$$

For Height of PQ

$$\frac{1}{v} + \frac{1}{-(f-x)} = \frac{1}{-f} \Rightarrow \frac{1}{v} = \frac{1}{(f-x)} - \frac{1}{f} \Rightarrow v = \frac{f(f-x)}{x}$$

$$\Rightarrow \frac{l_{PQ}}{PQ} = -\frac{f(f-x)}{x\{-(f-x)\}} = \left(\frac{f}{x}\right)$$

$$\Rightarrow l_{PQ} = \frac{f}{x} PQ = \left(\frac{f}{x}\right) \left(\frac{2(AB)x}{f}\right) \quad \left[\because PQ = \frac{2(AB)x}{f} \right]$$

$$l_{PQ} = 2AB$$

(Size of image is independent of x . So, final image will be of same height terminating at infinity)

5. In a radioactive decay chain, ${}_{90}^{232}\text{Th}$ nucleus decays to ${}_{82}^{212}\text{Pb}$ nucleus. Let N_α and N_β be the number of α and β^- particles, respectively, emitted in this decay process. Which of the following statements is (are) true?
- (A) $N_\alpha = 5$
- (B) $N_\alpha = 6$
- (C) $N_\beta = 2$
- (D) $N_\beta = 4$

Answer (A, C)

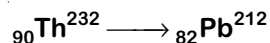
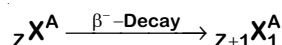
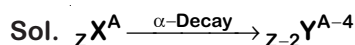

No. of α -particles emitted = $\frac{232 - 212}{4} = 5$

Since Z decreases by $(90 - 82) = 8$ only

Hence no. of β^- decay = 2

6. In an experiment to measure the speed of sound by a resonating air column, a tuning fork of frequency 500 Hz is used. The length of the air column is varied by changing the level of water in the resonance tube. Two successive resonances are heard at air columns of length 50.7 cm and 83.9 cm. Which of the following statements is (are) true?
- (A) The speed of sound determined from this experiment is 332 ms^{-1}
- (B) The end correction in this experiment is 0.9 cm
- (C) The wavelength of the sound wave is 66.4 cm
- (D) The resonance at 50.7 cm corresponds to the fundamental harmonic

Answer (A, B, C)

Sol. $(2n-1)\frac{\lambda}{4} = 50.7 + e$

$[2(n+1)-1]\frac{\lambda}{4} = 83.9 + e$

$\Rightarrow \frac{\lambda}{2} = 83.9 - 50.7 = 33.2 \text{ cm}$

$\therefore \lambda = 66.4 \text{ cm}$

$v = \lambda f = 66.4 \times 500 \times 10^{-2} \text{ m/s} = 332 \text{ m/s}$

For, $n = 2$, $e = -0.9 \text{ cm}$

SECTION 2 (Maximum Marks: 24)

- This section contains EIGHT (08) questions. The answer to each question is a NUMERICAL VALUE.
- For each question, enter the correct numerical value (in decimal notation, truncated/rounded-off to the second decimal place; e.g. 6.25, 7.00, -0.33, -.30, 30.27, -127.30) using the mouse and the on-screen virtual numeric keypad in the place designated to enter the answer.
- Answer to each question will be evaluated according to the following marking scheme:
 Full Marks : +3 If ONLY the correct numerical value is entered as answer.
 Zero Marks : 0 In all other cases.

7. A solid horizontal surface is covered with a thin layer of oil. A rectangular block of mass $m = 0.4$ kg is at rest on this surface. An impulse of 1.0 Ns is applied to the block at time $t = 0$ so that it starts moving along the x -axis with a velocity $v(t) = v_0 e^{-t/\tau}$, where v_0 is a constant and $\tau = 4$ s. The displacement of the block, in metres, at $t = \tau$ is _____. Take $e^{-1} = 0.37$.

Answer (6.30)

Sol. $v_0 = \frac{1}{0.4} = 2.5$ m/s

$$\frac{ds}{dt} = 2.5e^{-t/\tau}$$

$$\Rightarrow \int_0^s ds = \int_0^t 2.5e^{-t/\tau} dt$$

$$s = \left(\frac{-1}{\tau}\right) [e^{-t/\tau}]_0^t = \tau \times 2.5 [1 - e^{-t/\tau}]$$

At $t = \tau$, $s = 10[1 - e^{-1}] = 10 \times 0.63 = 6.30$ m

8. A ball is projected from the ground at an angle of 45° with the horizontal surface. It reaches a maximum height of 120 m and returns to the ground. Upon hitting the ground for the first time, it loses half of its kinetic energy. Immediately after the bounce, the velocity of the ball makes an angle of 30° with the horizontal surface. The maximum height it reaches after the bounce, in metres, is _____.

Answer (30.00)

Sol. $\therefore \frac{u^2 \sin^2 45^\circ}{2g} = 120$

$$\Rightarrow \frac{u^2}{4g} = 120$$

If speed is v after the first collision then

$$\frac{v^2}{4g} = 60 \text{ as } v = \frac{u}{\sqrt{2}}$$

$$\therefore h_{\max} = \frac{v^2 \sin^2 30^\circ}{2g} = \frac{v^2}{8g} = 30 \text{ m} = 30.00 \text{ m}$$

9. A particle, of mass 10^{-3} kg and charge 1.0 C, is initially at rest. At time $t = 0$, the particle comes under the influence of an electric field $\vec{E}(t) = E_0 \sin \omega t \hat{i}$, where $E_0 = 1.0$ NC $^{-1}$ and $\omega = 10^3$ rad s $^{-1}$. Consider the effect of only the electrical force on the particle. Then the maximum speed, in ms $^{-1}$, attained by the particle at subsequent times is _____.

Answer (2.00)

$$\text{Sol. } \vec{F} = q\vec{E} = 1.0 \text{ N} \sin(10^3 t) \hat{i}$$

$$a = \frac{F}{m} = 10^3 \sin(10^3 t)$$

$$\frac{dv}{dt} = 10^3 \sin(10^3 t)$$

$$\Rightarrow \int_0^v dv = \int_0^t 10^3 \sin(10^3 t) dt$$

$$v = \frac{10^3}{10^3} [1 - \cos(10^3 t)]$$

$$\Rightarrow v_{\max} = 2 \text{ m/s} = 2.00 \text{ m/s}$$

10. A moving coil galvanometer has 50 turns and each turn has an area $2 \times 10^{-4} \text{ m}^2$. The magnetic field produced by the magnet inside the galvanometer is 0.02 T . The torsional constant of the suspension wire is $10^{-4} \text{ N m rad}^{-1}$. When a current flows through the galvanometer, a full scale deflection occurs if the coil rotates by 0.2 rad . The resistance of the coil of the galvanometer is 50Ω . This galvanometer is to be converted into an ammeter capable of measuring current in the range $0 - 1.0 \text{ A}$. For this purpose, a shunt resistance is to be added in parallel to the galvanometer. The value of this shunt resistance, in ohms, is _____.

Answer (5.56)

$$\text{Sol. } \tau = BANi_m = K\theta$$

$$i_m = \frac{K\theta}{BAN} = \frac{10^{-4} \times 0.2}{0.02 \times 2 \times 10^{-4} \times 50}$$

$$= \frac{0.2}{2} = 0.1 \text{ A}$$

$$0.1 \times 50 = 0.9 \text{ S}$$

$$\Rightarrow S = \frac{50}{9} \Omega = 5.56 \Omega$$

11. A steel wire of diameter 0.5 mm and Young's modulus $2 \times 10^{11} \text{ Nm}^{-2}$ carries a load of mass M . The length of the wire with the load is 1.0 m . A vernier scale with 10 divisions is attached to the end of this wire. Next to the steel wire is a reference wire to which a main scale, of least count 1.0 mm , is attached. The 10 divisions of the vernier scale correspond to 9 divisions of the main scale. Initially, the zero of vernier scale coincides with the zero of main scale. If the load on the steel wire is increased by 1.2 kg , the vernier scale division which coincides with a main scale division is _____. Take $g = 10 \text{ ms}^{-2}$ and $\pi = 3.2$.

Answer (3.00)

$$\text{Sol. } \Delta L = \frac{W}{\left(\frac{YA}{L}\right)}$$

$$= \frac{1.2 \times 10 \times 4 \times 1}{2 \times 10^{11} \times \pi \times (0.5)^2 \times (10^{-6})}$$

$$= 0.3 \text{ mm}$$

$$\text{L.C. of vernier} = \left(1 - \frac{9}{10}\right) \text{ mm} = 0.1 \text{ mm}$$

$$\therefore \text{ Vernier reading} = 3$$

12. One mole of a monatomic ideal gas undergoes an adiabatic expansion in which its volume becomes eight times its initial value. If the initial temperature of the gas is 100 K and the universal gas constant $R = 8.0 \text{ J mol}^{-1} \text{ K}^{-1}$, the decrease in its internal energy, in Joule, is ____.

Answer (900.00)

Sol. $n = 1, \gamma = \frac{5}{3}$

$$T_1 V_1^{\gamma-1} = T_2 V_2^{\gamma-1}$$

$$\Rightarrow T_2 = T_1 \left(\frac{V_1}{V_2} \right)^{\gamma-1} = 100 \times \left(\frac{1}{8} \right)^{\frac{2}{3}}$$

$$\Rightarrow T_2 = 25 \text{ K}$$

$$\therefore \Delta U = n \times \left(\frac{3R}{2} \right) (T_2 - T_1)$$

$$= 1 \times \frac{3}{2} \times 8 \times (25 - 100)$$

$$= -900 \text{ J}$$

$$\therefore \text{Decrease in internal energy} = 900 \text{ J}$$

13. In a photoelectric experiment a parallel beam of monochromatic light with power of 200 W is incident on a perfectly absorbing cathode of work function 6.25 eV. The frequency of light is just above the threshold frequency so that the photoelectrons are emitted with negligible kinetic energy. Assume that the photoelectron emission efficiency is 100%. A potential difference of 500 V is applied between the cathode and the anode. All the emitted electrons are incident normally on the anode and are absorbed. The anode experiences a force $F = n \times 10^{-4} \text{ N}$ due to the impact of the electrons. The value of n is _____. Mass of the electron $m_e = 9 \times 10^{-31} \text{ kg}$ and $1.0 \text{ eV} = 1.6 \times 10^{-19} \text{ J}$.

Answer (24.00)

Sol. $P = 200 \text{ J/s}$

$$\text{No. of photons per second (N)} = \frac{200}{(6.25 \times 1.6 \times 10^{-19})}$$

$$= 2 \times 10^{20}$$

$$\Delta p = \sqrt{2m(\text{KE})} = \sqrt{2m(\text{eV})}$$

$$= \sqrt{2 \times 9 \times 10^{-31} \times 1.6 \times 10^{-19} \times 500}$$

$$= 12 \times 10^{-24}$$

$$\therefore F = \Delta p \times N = 12 \times 10^{-24} \times 2 \times 10^{20}$$

$$= 24 \times 10^{-4} \text{ N}$$

14. Consider a hydrogen-like ionized atom with atomic number Z with a single electron. In the emission spectrum of this atom, the photon emitted in the $n = 2$ to $n = 1$ transition has energy 74.8 eV higher than the photon emitted in the $n = 3$ to $n = 2$ transition. The ionization energy of the hydrogen atom is 13.6 eV. The value of Z is ____.

Answer (3.00)

Sol. $13.6 \left(\frac{1}{1} - \frac{1}{4} \right) Z^2 = 74.8 + 13.6 \times \left(\frac{1}{4} - \frac{1}{9} \right) Z^2$

$$\Rightarrow 13.6 Z^2 \left(\frac{3}{4} - \frac{5}{36} \right) = 74.8$$

$$\Rightarrow Z^2 = 9$$

$$\Rightarrow Z = 3$$

SECTION 3 (Maximum Marks: 12)

- This section contains **FOUR (04)** questions.
- Each question has **TWO (02)** matching lists: **LIST-I** and **LIST-II**.
- **FOUR** options are given representing matching of elements from **LIST-I** and **LIST-II**. **ONLY ONE** of these four options corresponds to a correct matching.
- For each question, choose the option corresponding to the correct matching.
- For each question, marks will be awarded according to the following marking scheme:
Full Marks : +3 If **ONLY** the option corresponding to the correct matching is chosen.
Zero Marks : 0 If none of the options is chosen (i.e. the question is unanswered).
Negative Marks : -1 In all other cases.

15. The electric field E is measured at a point $P(0, 0, d)$ generated due to various charge distributions and the dependence of E on d is found to be different for different charge distributions. List-I contains different relations between E and d . List-II describes different electric charge distributions, along with their locations. Match the functions in List-I with the related charge distributions in List-II.

LIST-I

P. E is independent of d

Q. $E \propto \frac{1}{d}$

R. $E \propto \frac{1}{d^2}$

S. $E \propto \frac{1}{d^3}$

LIST-II

1. A point charge Q at the origin
2. A small dipole with point charges Q at $(0, 0, l)$ and $-Q$ at $(0, 0, -l)$. Take $2l \ll d$
3. An infinite line charge coincident with the x -axis, with uniform linear charge density λ
4. Two infinite wires carrying uniform linear charge density parallel to the x -axis. The one along $(y = 0, z = l)$ has a charge density $+\lambda$ and the one along $(y = 0, z = -l)$ has a charge density $-\lambda$. Take $2l \ll d$.
5. Infinite plane charge coincident with the xy -plane with uniform surface charge density

- (A) $P \rightarrow 5; Q \rightarrow 3, 4; R \rightarrow 1; S \rightarrow 2$
 (C) $P \rightarrow 5; Q \rightarrow 3; R \rightarrow 1, 2; S \rightarrow 4$

- (B) $P \rightarrow 5; Q \rightarrow 3; R \rightarrow 1, 4; S \rightarrow 2$
 (D) $P \rightarrow 4; Q \rightarrow 2, 3; R \rightarrow 1; S \rightarrow 5$

Answer (B)

Sol. List-II

(1) $E = \frac{1}{4\pi\epsilon_0} \frac{Q}{d^2} \Rightarrow E \propto \frac{1}{d^2}$

(2) $E_{\text{axis}} = \frac{1}{4\pi\epsilon_0} \frac{2Q(2l)}{d^3} \Rightarrow E \propto \frac{1}{d^3}$

(3) $E = \frac{\lambda}{2\pi\epsilon_0 d} \Rightarrow E \propto \frac{1}{d}$

(4) $E = \frac{\lambda}{2\pi\epsilon_0(d-l)} - \frac{\lambda}{2\pi\epsilon_0(d+l)} = \frac{\lambda(2l)}{2\pi\epsilon_0 d^2} \Rightarrow E \propto \frac{1}{d^2}$

(5) $E = \frac{\sigma}{2\epsilon_0} \Rightarrow E$ is independent of d

16. A planet of mass M , has two natural satellites with masses m_1 and m_2 . The radii of their circular orbits are R_1 and R_2 respectively. Ignore the gravitational force between the satellites. Define v_1 , L_1 , K_1 and T_1 to be, respectively, the orbital speed, angular momentum, kinetic energy and time period of revolution of satellite 1; and v_2 , L_2 , K_2 and T_2 to be the corresponding quantities of satellite 2. Given $m_1/m_2 = 2$ and $R_1/R_2 = 1/4$, match the ratios in List-I to the numbers in List-II.

LIST-I

P. $\frac{v_1}{v_2}$

Q. $\frac{L_1}{L_2}$

R. $\frac{K_1}{K_2}$

S. $\frac{T_1}{T_2}$

(A) $P \rightarrow 4; Q \rightarrow 2; R \rightarrow 1; S \rightarrow 3$

(C) $P \rightarrow 2; Q \rightarrow 3; R \rightarrow 1; S \rightarrow 4$

LIST-II

1. $\frac{1}{8}$

2. 1

3. 2

4. 8

(B) $P \rightarrow 3; Q \rightarrow 2; R \rightarrow 4; S \rightarrow 1$

(D) $P \rightarrow 2; Q \rightarrow 3; R \rightarrow 4; S \rightarrow 1$

Answer (B)

Sol. $\frac{GMm}{R^2} = \frac{mv^2}{R} \Rightarrow v = \sqrt{\frac{GM}{R}}$

Let $R_1 = R \Rightarrow R_2 = 4R$

$m_2 = m \Rightarrow m_1 = 2m$

List-I

(P) $\frac{v_1}{v_2} = \sqrt{\frac{R_2}{R_1}} = \sqrt{\frac{4R}{R}} = 2:1$

(Q) $L = mvR$

$\frac{L_1}{L_2} = \frac{R(2m)v_1}{4R(m)v_2} = \frac{1}{2}(2) = 1:1$

(R) $\frac{K_1}{K_2} = \frac{\frac{1}{2}(2m)v_1^2}{\frac{1}{2}(m)v_2^2} = 2(4) = 8:1$

(S) $\frac{T_1}{T_2} = \left(\frac{R_1}{R_2}\right)^{3/2} = \left(\frac{1}{4}\right)^{3/2} = 1:8$

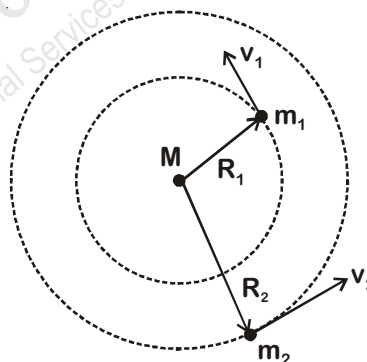

17. One mole of a monatomic ideal gas undergoes four thermodynamic processes as shown schematically in the PV-diagram below. Among these four processes, one is isobaric, one is isochoric, one is isothermal and one is adiabatic. Match the processes mentioned in List-I with the corresponding statements in List-II.

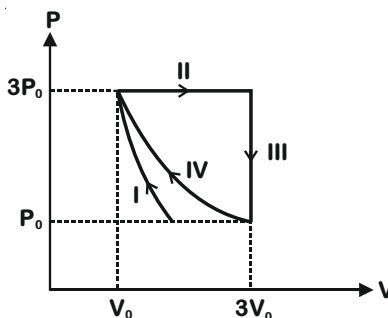

LIST-I

- P. In process I
- Q. In process II
- R. In process III

S. In process IV

- (A) P → 4; Q → 3; R → 1; S → 2
- (B) P → 1; Q → 3; R → 2; S → 4
- (C) P → 3; Q → 4; R → 1; S → 2
- (D) P → 3; Q → 4; R → 2; S → 1

LIST-II

- 1. Work done by the gas is zero
- 2. Temperature of the gas remains unchanged
- 3. No heat is exchanged between the gas and its surroundings
- 4. Work done by the gas is $6P_0V_0$

Answer (C)

Sol. $\left(\frac{dP}{dV}\right)_{\text{adiabatic}} = \gamma \left(\frac{dP}{dV}\right)_{\text{isothermal}}$

List-I

(P) Process I ⇒ Adiabatic ⇒ Q = 0

(Q) Process II ⇒ Isobaric

$$W = P\Delta V = 3P_0 [3V_0 - V_0] = 6P_0V_0$$

(R) Process III ⇒ Isochoric ⇒ W = 0

(S) Process (IV) ⇒ Isothermal ⇒ Temperature = Constant

18. In the List-I below, four different paths of a particle are given as functions of time. In these functions, α and β are positive constants of appropriate dimensions and $\alpha \neq \beta$. In each case, the force acting on the particle is either zero or conservative. In List-II, five physical quantities of the particle are mentioned : \vec{p} is the linear momentum, \vec{L} is the angular momentum about the origin, K is the kinetic energy, U is the potential energy and E is the total energy. Match each path in List-I with those quantities in List-II, which are conserved for that path.

LIST-I

P. $\vec{r}(t) = \alpha t \hat{i} + \beta t \hat{j}$

Q. $\vec{r}(t) = \alpha \cos \omega t \hat{i} + \beta \sin \omega t \hat{j}$

R. $\vec{r}(t) = \alpha(\cos \omega t \hat{i} + \sin \omega t \hat{j})$

S. $\vec{r}(t) = \alpha t \hat{i} + \frac{\beta}{2} t^2 \hat{j}$

LIST-II

1. \vec{p}

2. \vec{L}

3. K

4. U

5. E

- (A) P → 1, 2, 3, 4, 5; Q → 2, 5; R → 2, 3, 4, 5; S → 5
- (B) P → 1, 2, 3, 4, 5; Q → 3, 5; R → 2, 3, 4, 5; S → 2, 5
- (C) P → 2, 3, 4; Q → 5; R → 1, 2, 4; S → 2, 5
- (D) P → 1, 2, 3, 5; Q → 2, 5; R → 2, 3, 4, 5; S → 2, 5

Answer (A)

Sol. When force F = 0 ⇒ potential energy U = constant

F ≠ 0 ⇒ force is conservative ⇒ Total energy E = constant

List-I

(P) $\vec{r}(t) = \alpha t \hat{i} + \beta t \hat{j}$

$$\frac{d\vec{r}}{dt} = \vec{v} = \alpha \hat{i} + \beta \hat{j} = \text{constant} \Rightarrow \vec{p} = \text{constant}$$

$$|\vec{v}| = \sqrt{\alpha^2 + \beta^2} = \text{constant} \Rightarrow K = \text{constant}$$

$$\frac{d\vec{v}}{dt} = \vec{a} = 0 \Rightarrow F = 0 \Rightarrow U = \text{constant}$$

$$E = U + K = \text{constant}$$

$$\vec{L} = m(\vec{r} \times \vec{v}) = 0$$

$$\vec{L} = \text{constant}$$

$$P \rightarrow 1, 2, 3, 4, 5$$

(Q) $\vec{r}(t) = \alpha \cos \omega t \hat{i} + \beta \sin \omega t \hat{j}$

$$\frac{d\vec{r}}{dt} = \vec{v} = \alpha \omega \sin \omega t (-\hat{i}) + \beta \omega \cos \omega t \hat{j} \neq \text{constant} \Rightarrow \vec{p} \neq \text{constant}$$

$$|\vec{v}| = \omega \sqrt{(\alpha \sin \omega t)^2 + (\beta \cos \omega t)^2} \neq \text{constant} \Rightarrow K \neq \text{constant}$$

$$\vec{a} = \frac{d\vec{v}}{dt} = -\omega^2 \vec{r} \neq 0$$

$$\Rightarrow E = \text{constant} = K + U$$

$$\text{But } K \neq \text{constant} \Rightarrow U \neq \text{constant}$$

$$\vec{L} = m(\vec{r} \times \vec{v}) = m\omega\alpha\beta(\hat{k}) = \text{constant}$$

$$Q \rightarrow 2, 5$$

(R) $\vec{r}(t) = \alpha(\cos \omega t \hat{i} + \sin \omega t \hat{j})$

$$\frac{d\vec{r}}{dt} = \vec{v} = \alpha\omega[\sin \omega t (-\hat{i}) + \cos \omega t \hat{j}] \neq \text{constant} \Rightarrow \vec{p} \neq \text{constant}$$

$$|\vec{v}| = \alpha\omega = \text{constant} \Rightarrow K = \text{constant}$$

$$\vec{a} = \frac{d\vec{v}}{dt} = -\omega^2 \vec{r} \neq 0 \Rightarrow E = \text{constant}, U = \text{constant}$$

$$\vec{L} = m(\vec{r} \times \vec{v}) = m\omega\alpha^2 \hat{k} = \text{constant}$$

$$R \rightarrow 2, 3, 4, 5$$

(S) $\vec{r}(t) = \alpha t \hat{i} + \frac{\beta}{2} t^2 \hat{j}$

$$\frac{d\vec{r}}{dt} = \vec{v} = \alpha \hat{i} + \beta t \hat{j} \neq \text{constant} \Rightarrow \vec{p} \neq \text{constant}$$

$$|\vec{v}| = \sqrt{\alpha^2 + (\beta t)^2} \neq \text{constant} \Rightarrow K \neq \text{constant}$$

$$\vec{a} = \frac{d\vec{v}}{dt} = \beta \hat{j} \neq 0 \Rightarrow E = \text{constant} = K + U$$

$$\text{But } K \neq \text{constant}$$

$$\therefore U \neq \text{constant}$$

$$\vec{L} = m(\vec{r} \times \vec{v}) = \frac{1}{2} \alpha \beta t^2 \hat{k} \neq \text{constant}$$

$$S \rightarrow 5$$

PART-II : CHEMISTRY

SECTION - 1 (Maximum Marks : 24)

- This section contains SIX (06) questions.
- Each question has FOUR options for correct answer(s). ONE OR MORE THAN ONE of these four option(s) is (are) correct option(s).
- For each question, choose the correct option(s) to answer the question.
- Answer to each question will be evaluated according to the following marking scheme:

Full Marks : +4 If only (all) the correct option(s) is (are) chosen.

Partial Marks : +3 If all the four options are correct but ONLY three options are chosen.

Partial Marks : +2 If three or more options are correct but ONLY two options are chosen, both of which are correct options.

Partial Marks : +1 If two or more options are correct but ONLY one option is chosen and it is a correct option.

Zero Marks : 0 If none of the options is chosen (i.e. the question is unanswered).

Negative Marks : -2 In all other cases.

For Example: If first, third and fourth are the ONLY three correct options for a question with second option being an incorrect option; selecting only all the three correct options will result in +4 marks. Selecting only two of the three correct options (e.g. the first and fourth options), without selecting any incorrect option (second option in this case), will result in +2 marks. Selecting only one of the three correct options (either first or third or fourth option), without selecting any incorrect option (second option in this case), will result in +1 marks. Selecting any incorrect option(s) (second option in this case), with or without selection of any correct option(s) will result in -2 marks.

1. The correct option(s) regarding the complex $[\text{Co}(\text{en})(\text{NH}_3)_3(\text{H}_2\text{O})]^{3+}$ ($\text{en} = \text{H}_2\text{NCH}_2\text{CH}_2\text{NH}_2$) is (are)
- It has two geometrical isomers
 - It will have three geometrical isomers if bidentate 'en' is replaced by two cyanide ligands
 - It is paramagnetic
 - It absorbs light at longer wavelength as compared to $[\text{Co}(\text{en})(\text{NH}_3)_4]^{3+}$

Answer (A, B, D)

Sol. (A) $[\text{Co}(\text{en})(\text{NH}_3)_3(\text{H}_2\text{O})]^{3+}$

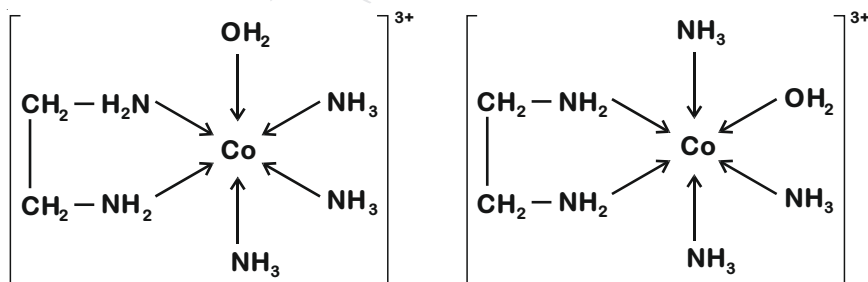

(B) $[\text{Co}(\text{CN})_2(\text{NH}_3)_3(\text{H}_2\text{O})]^{1+}$

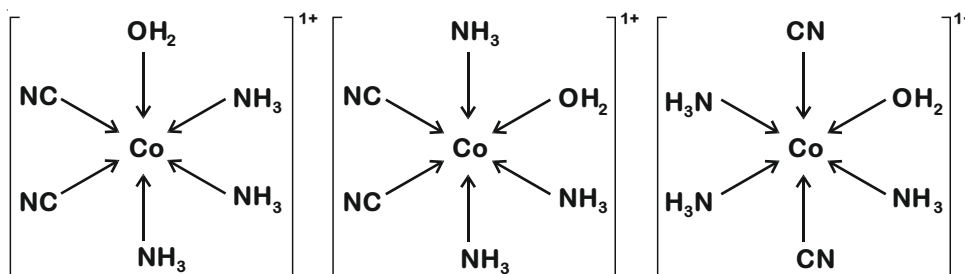

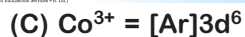

in presence of en and NH_3 it form low spin complex.

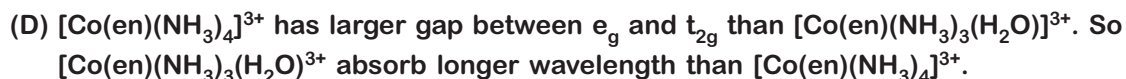

2. The correct option(s) to distinguish nitrate salts of Mn^{2+} and Cu^{2+} taken separately is (are)
- (A) Mn^{2+} shows the characteristic green colour in the flame test
 (B) Only Cu^{2+} shows the formation of precipitate by passing H_2S in acidic medium
 (C) Only Mn^{2+} shows the formation of precipitate by passing H_2S in faintly basic medium
 (D) Cu^{2+}/Cu has higher reduction potential than Mn^{2+}/Mn (measured under similar conditions)

Answer (B, D)

Sol. (A) Manganese show pale purple colour in flame test.

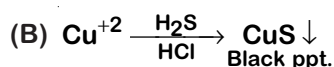

(C) Both Cu^{+2} and Mn^{+2} form precipitate with H_2S in basic medium.

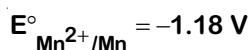
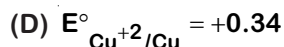

3. Aniline reacts with mixed acid (conc. HNO_3 and conc. H_2SO_4) at 288 K to give P (51 %), Q (47%) and R (2%). The major product(s) of the following reaction sequence is (are)

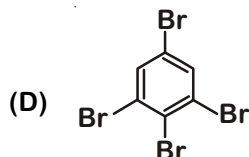
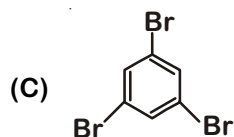
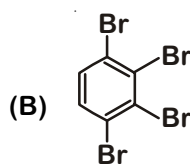
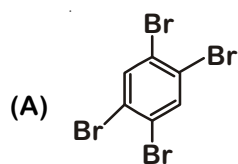
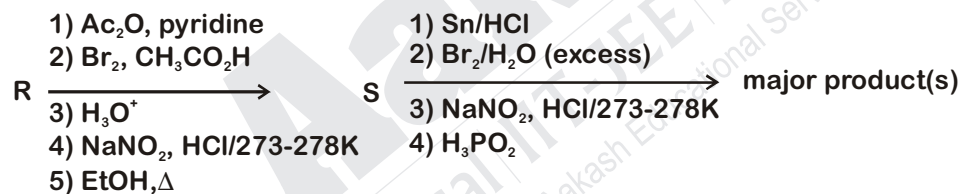

Answer (D)

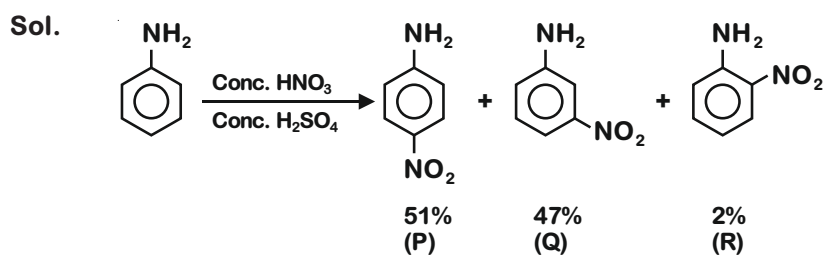

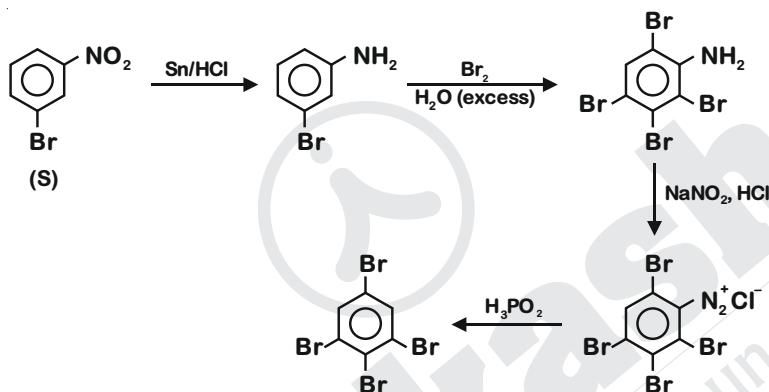
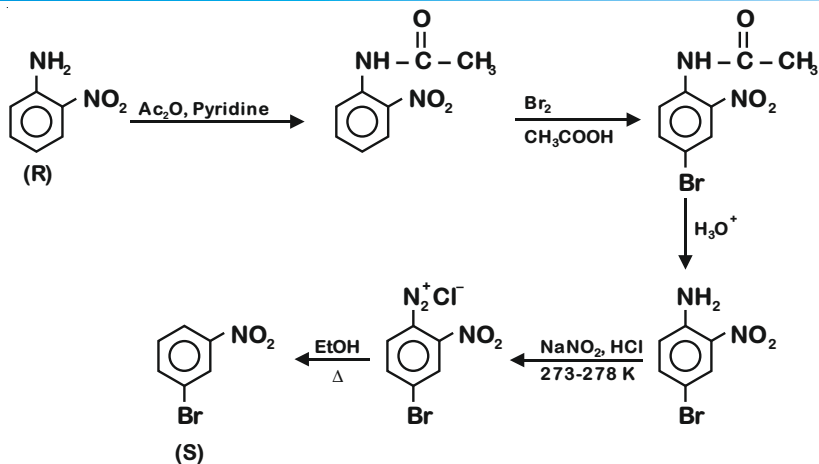

4. The Fischer presentation of D-glucose is given below.

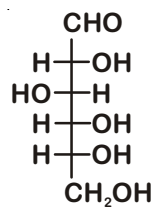

D-glucose

The correct structure(s) of β -L-glucopyranose is (are)

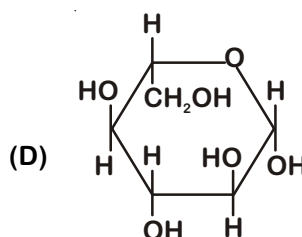
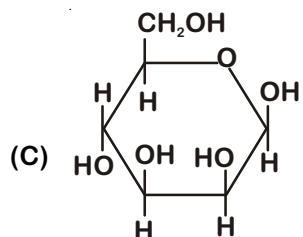
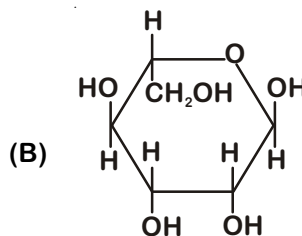
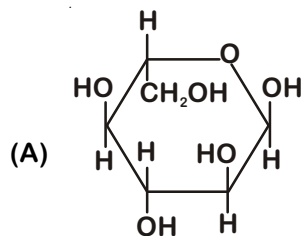

Answer (D)

Sol. Structure of β -L-Glucopyranose is

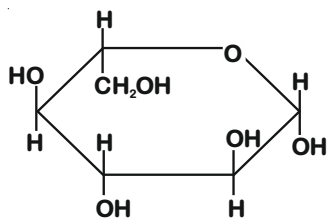

5. For a first order reaction $A(g) \rightarrow 2B(g) + C(g)$ at constant volume and 300 K, the total pressure at the beginning ($t = 0$) and at time t are P_0 and P_t , respectively. Initially, only A is present with concentration $[A]_0$, and $t_{1/3}$ is the time required for the partial pressure of A to reach $1/3^{\text{rd}}$ of its initial value. The correct option(s) is (are)

(Assume that all these gases behave as ideal gases)

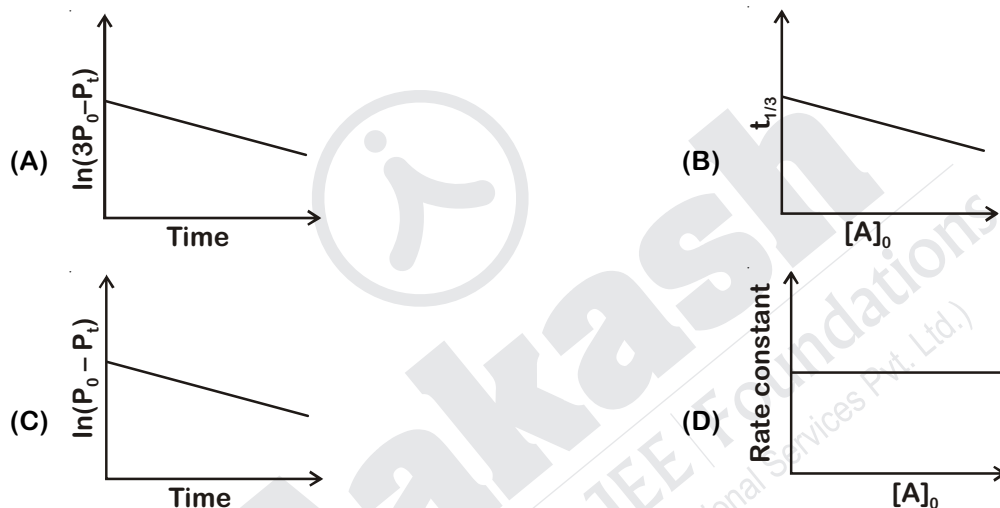

Answer (A, D)



$$\begin{array}{ccc} P_0 & - & - \\ P_0 - P & 2P & P \end{array}$$

$$P_t = P_0 + 2P$$

$$P = \frac{P_t - P_0}{2}$$

$$Kt = \ln \left[\frac{P_0}{P_0 - \left(\frac{P_t - P_0}{2} \right)} \right] = \ln \frac{2P_0}{3P_0 - P_t}$$

$$Kt = \ln 2P_0 - \ln(3P_0 - P_t)$$

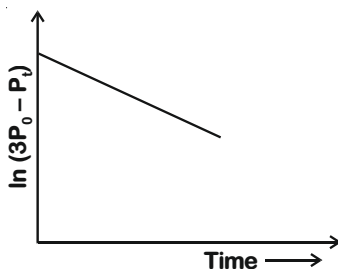

Rate constant of reaction is independent of initial concentration.

6. For a reaction, $A \rightleftharpoons P$, the plots of $[A]$ and $[P]$ with time at temperatures T_1 and T_2 are given below.

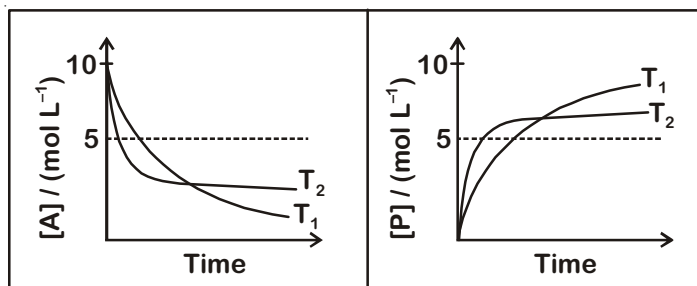

If $T_2 > T_1$, the correct statement(s) is (are)

(Assume ΔH^\ominus and ΔS^\ominus are independent of temperature and ratio of $\ln K$ at T_1 to $\ln K$ at T_2 is greater than T_2/T_1 . Here H, S, G and K are enthalpy, entropy, Gibbs energy and equilibrium constant, respectively.)

- (A) $\Delta H^\ominus < 0, \Delta S^\ominus < 0$ (B) $\Delta G^\ominus < 0, \Delta H^\ominus > 0$
 (C) $\Delta G^\ominus < 0, \Delta S^\ominus < 0$ (D) $\Delta G^\ominus < 0, \Delta S^\ominus > 0$

Answer (A, C)

Sol. $\frac{\ln K_1}{\ln K_2} > \frac{T_2}{T_1}$

\Rightarrow On increasing temperature, K decreases.

$\therefore \Delta H^\ominus < 0$

From graph $K > 1 \Rightarrow \Delta G^\ominus < 0$

$$\frac{\ln K_1}{\ln K_2} = \frac{\frac{-\Delta H^\ominus}{T_1 R} + \frac{\Delta S^\ominus}{R}}{\frac{-\Delta H^\ominus}{T_2 R} + \frac{\Delta S^\ominus}{R}} > \frac{T_2}{T_1}$$

$$\frac{(-\Delta H^\ominus + T_1 \Delta S^\ominus)}{(-\Delta H^\ominus + T_2 \Delta S^\ominus)} \frac{T_2}{T_1} > \frac{T_2}{T_1}$$

$$-\Delta H^\ominus + T_1 \Delta S^\ominus > -\Delta H^\ominus + T_2 \Delta S^\ominus$$

$\Rightarrow \Delta S^\ominus < 0$

SECTION 2 (Maximum Marks: 24)

- This section contains EIGHT (08) questions. The answer to each question is a NUMERICAL VALUE.
- For each question, enter the correct numerical value (in decimal notation, truncated/rounded-off to the second decimal place; e.g. 6.25, 7.00, -0.33, -.30, 30.27, -127.30) using the mouse and the on-screen virtual numeric keypad in the place designated to enter the answer.
- Answer to each question will be evaluated according to the following marking scheme:
 Full Marks : +3 If ONLY the correct numerical value is entered as answer.
 Zero Marks : 0 In all other cases.

7. The total number of compounds having at least one bridging oxo group among the molecules given below is _____.

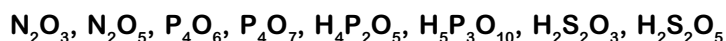

Answer (5.00)

Sol.

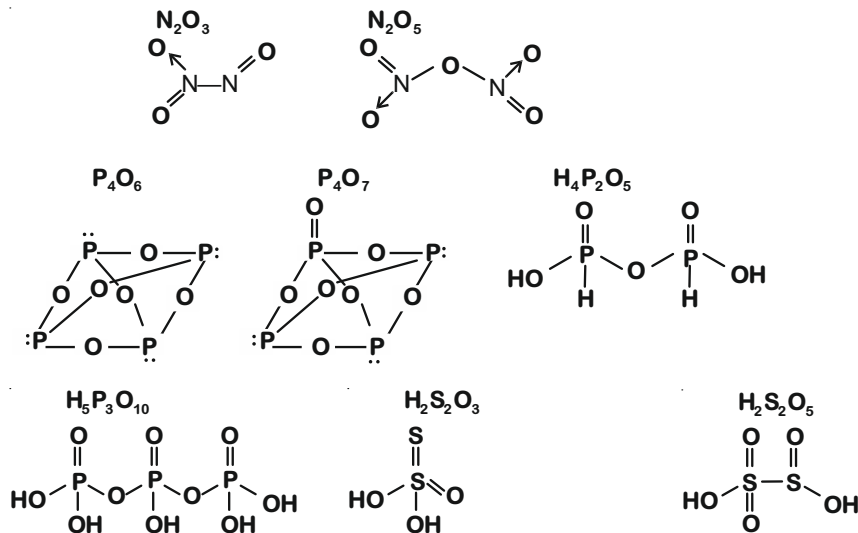

8. Galena (an ore) is partially oxidized by passing air through it at high temperature. After some time, the passage of air is stopped, but the heating is continued in a closed furnace such that the contents undergo self-reduction. The weight (in kg) of Pb produced per kg of O_2 consumed is _____.

(Atomic weights in $g\ mol^{-1}$: O = 16, S = 32, Pb = 207)

Answer (6.47)

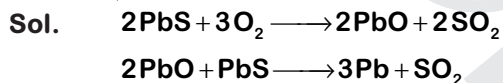

3 moles of O_2 produce 3 moles of lead

96 kg of oxygen produce 621 kg of lead.

1 kg of oxygen produce $\frac{621}{96} = 6.468 = 6.47\ kg$

9. To measure the quantity of $MnCl_2$ dissolved in an aqueous solution, it was completely converted to $KMnO_4$ using the reaction,



Few drops of concentrated HCl were added to this solution and gently warmed. Further, oxalic acid (225 mg) was added in portions till the colour of the permanganate ion disappeared. The quantity of $MnCl_2$ (in mg) present in the initial solution is _____.

(Atomic weights in $g\ mol^{-1}$: Mn = 55, Cl = 35.5)

Answer (126.00)

Sol. From POAC,

m moles of $MnCl_2 = m$ moles of $KMnO_4 = x$ (let)

and, meq of $KMnO_4 =$ meq of oxalic acid

$$x \times 5 = \left(\frac{225}{90} \right) \times 2$$

$$x = 1$$

\therefore m moles of $MnCl_2 = 1$

mg of $MnCl_2 = (55 + 71) = 126\ mg$

10. For the given compound X, the total number of optically active stereoisomers is _____.

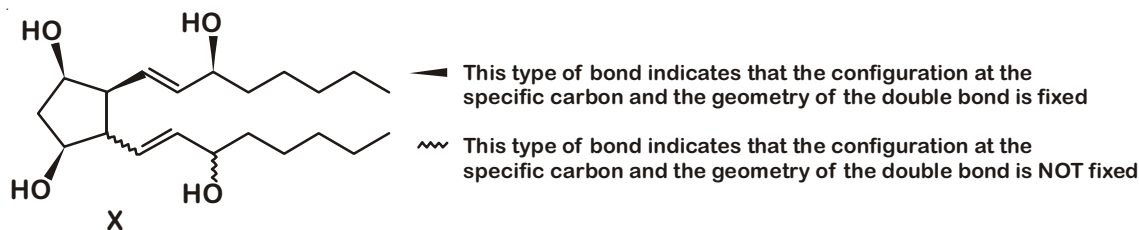

Answer (7.00)

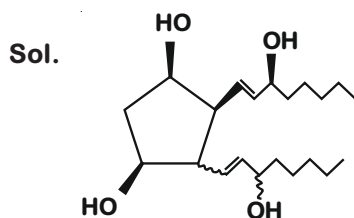

Only three stereocenters are present.

$$\therefore \text{Total isomer} = 2^3 = 8$$

But one is optically inactive.

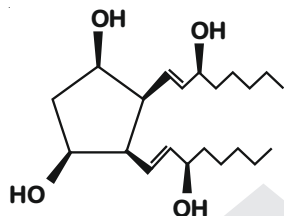

11. In the following reaction sequence, the amount of D (in g) formed from 10 moles of acetophenone is _____.

(Atomic weights in g mol^{-1} : H = 1, C = 12, N = 14, O = 16, Br = 80. The yield (%) corresponding to the product in each step is given in the parenthesis)

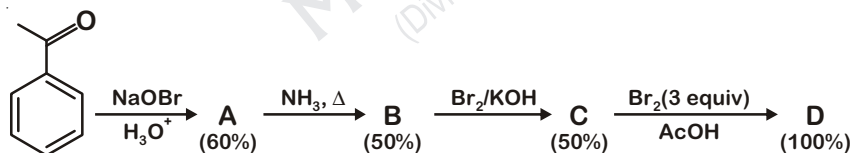

Answer (495.00)

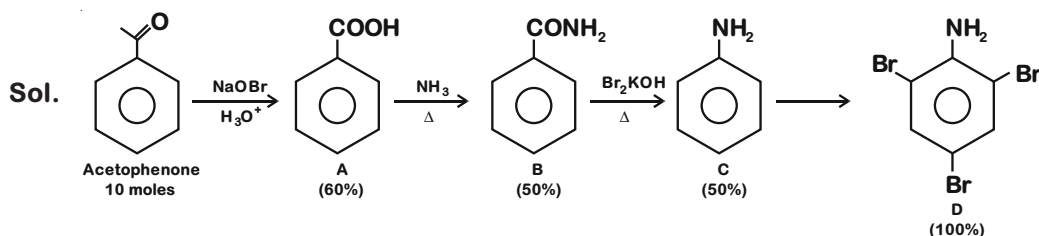

$$\text{Yield of D in moles} = 10 \times \frac{60}{100} \times \frac{50}{100} \times \frac{50}{100} = 1.5 \text{ moles}$$

$$\text{Amount of D} = 1.5 \times 330 = 495.00$$

12. The surface of copper gets tarnished by the formation of copper oxide. N_2 gas was passed to prevent the oxide formation during heating of copper at 1250 K. However, the N_2 gas contains 1 mole % of water vapour as impurity. The water vapour oxidises copper as per the reaction given below:

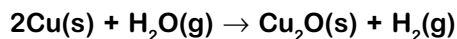

P_{H_2} is the minimum partial pressure of H_2 (in bar) needed to prevent the oxidation at 1250 K. The value of $\ln(P_{H_2})$ is _____.

(Given: total pressure = 1 bar, R (universal gas constant) = $8 \text{ J K}^{-1} \text{ mol}^{-1}$, $\ln(10) = 2.3$. $Cu(s)$ and $Cu_2O(s)$ are mutually immiscible.)

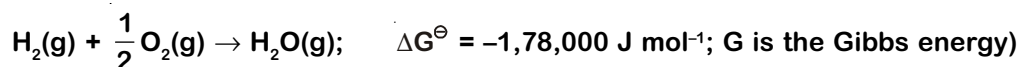
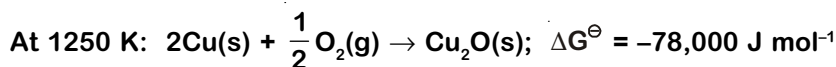

Answer (-14.60)

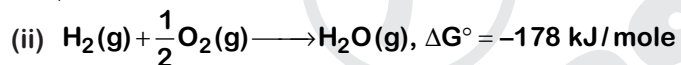
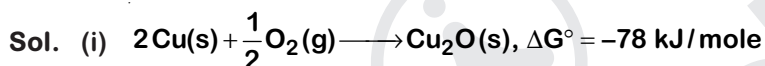

(i) - (ii)

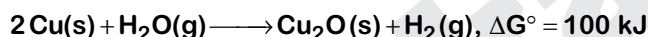

$$\Delta G = \Delta G^\ominus + RT \ln K \geq 0$$

$$\Rightarrow 10^5 + 8 \times 1250 \ln \left(\frac{P_{H_2}}{P_{H_2O}} \right) \geq 0$$

$$10^4 \ln \left(\frac{P_{H_2}}{P_{H_2O}} \right) + 10^5 \geq 0$$

$$\ln P_{H_2} - \ln P_{H_2O} \geq -10$$

$$\text{Now, } P_{H_2O} = X_{H_2O} \times P_{\text{Total}} = 0.01 \times 1 = 10^{-2}$$

$$\therefore \ln P_{H_2} + 2 \ln 10 \geq -10$$

$$\ln P_{H_2} + 4.6 \geq -10$$

$$\ln P_{H_2} \geq -14.60$$

13. Consider the following reversible reaction,

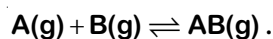

The activation energy of the backward reaction exceeds that of the forward reaction by $2RT$ (in J mol^{-1}). If the pre-exponential factor of the forward reaction is 4 times that of the reverse reaction, the absolute value of ΔG^\ominus (in J mol^{-1}) for the reaction at 300 K is _____.

(Given; $\ln(2) = 0.7$, $RT = 2500 \text{ J mol}^{-1}$ at 300 K and G is the Gibbs energy)

Answer (8500.00)

Sol. $A(g) + B(g) \rightleftharpoons AB(g)$

$$E_{a_b} - E_{a_f} = 2RT$$

$$\frac{A_f}{A_b} = 4$$

$$K = \frac{K_f}{K_b}$$

$$K_f = A_f e^{-E_{a_f}/RT}$$

$$K_b = A_b e^{-E_{a_b}/RT}$$

$$\frac{K_f}{K_b} = \frac{A_f}{A_b} e^{(E_{a_b} - E_{a_f})/RT}$$

$$\Rightarrow K = 4e^{2RT/RT}$$

$$K = 4e^2$$

$$\Delta G^\circ = -RT \ln K$$

$$= -RT (2 + \ln 4)$$

$$= -2500 (2 + 2 \times 0.7)$$

$$= -8500 \text{ J mol}^{-1}$$

Absolute value is 8500.00

14. Consider an electrochemical cell: $A(s) | A^{n+}(\text{aq}, 2 \text{ M}) || B^{2n+}(\text{aq}, 1 \text{ M}) | B(s)$. The value of ΔH^\ominus for the cell reaction is twice that of ΔG^\ominus at 300 K. If the emf of the cell is zero, the ΔS^\ominus (in $\text{J K}^{-1} \text{ mol}^{-1}$) of the cell reaction per mole of B formed at 300 K is .

(Given: $\ln(2) = 0.7$, R (universal gas constant) = $8.3 \text{ J K}^{-1} \text{ mol}^{-1}$. H, S and G are enthalpy, entropy and Gibbs energy, respectively.)

Answer (-11.62)

Sol. $A \longrightarrow A^{n+} + ne^-$

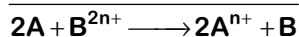

$$\Delta H^\circ = 2\Delta G^\circ, E_{\text{cell}} = 0$$

$$\Delta G^\circ = \Delta H^\circ - T\Delta S^\circ$$

$$\Rightarrow \Delta G^\circ = T\Delta S^\circ \Rightarrow \Delta S^\circ = \frac{\Delta G^\circ}{T}$$

$$\Delta S^\circ = \frac{-RT \ln K}{T} = -R \ln \frac{[A^{n+}]^2}{[B^{2n+}]}$$

$$= -8.3 \times \ln \frac{2^2}{1}$$

$$\Rightarrow \Delta S^\circ = -11.62 \text{ JK}^{-1} \text{ mol}^{-1}$$

SECTION 3 (Maximum Marks: 12)

- This section contains **FOUR (04)** questions.
- Each question has **TWO (02)** matching lists: **LIST-I** and **LIST-II**.
- **FOUR** options are given representing matching of elements from **LIST-I** and **LIST-II**. **ONLY ONE** of these four options corresponds to a correct matching.
- For each question, choose the option corresponding to the correct matching.
- For each question, marks will be awarded according to the following marking scheme:
Full Marks : +3 If **ONLY** the option corresponding to the correct matching is chosen.
Zero Marks : 0 If none of the options is chosen (i.e. the question is unanswered).
Negative Marks : -1 In all other cases.

15. Match each set of hybrid orbitals from LIST-I with complex(es) given in LIST-II.

List-I	List-II
P. dsp^2	1. $[FeF_6]^{4-}$
Q. sp^3	2. $[Ti(H_2O)_3Cl_3]$
R. sp^3d^2	3. $[Cr(NH_3)_6]^{3+}$
S. d^2sp^3	4. $[FeCl_4]^{2-}$
	5. $Ni(CO)_4$
	6. $[Ni(CN)_4]^{2-}$

The correct option is

- (A) P → 5; Q → 4,6; R → 2,3; S → 1
 (B) P → 5,6; Q → 4; R → 3; S → 1,2
 (C) P → 6; Q → 4,5; R → 1; S → 2,3
 (D) P → 4,6; Q → 5,6; R → 1,2; S → 3

Answer (C)

Sol. 1. $[FeF_6]^{4-}$



High spin complex because F^- is weak field ligand.

sp^3d^2

2. $[Ti(H_2O)_3Cl_3]$

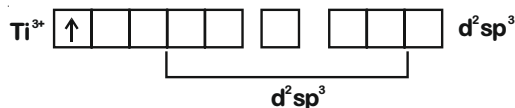

3. $[Cr(NH_3)_6]^{3+}$

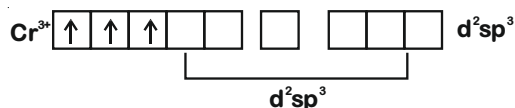

4. $[FeCl_4]^{2-}$

Fe^{+2} : $3d^6$, Cl^- is weak field ligand.

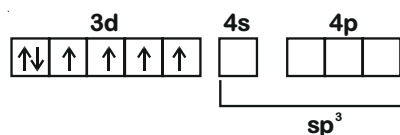

5. $\text{Ni}(\text{CO})_4$

$\text{Ni}^0 - 3d^8 4s^2$, CO is strong field ligand

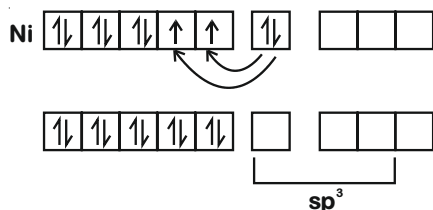

6. $[\text{Ni}(\text{CN})_4]^{2-}$

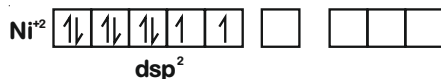

CN⁻ is strong field ligand.

16. The desired product X can be prepared by reacting the major product of the reactions in LIST-I with one or more appropriate reagents in LIST-II.

(given, order of migratory aptitude: aryl > alkyl > hydrogen)

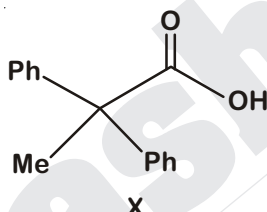

List-I

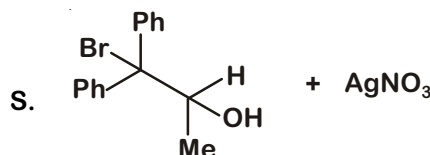
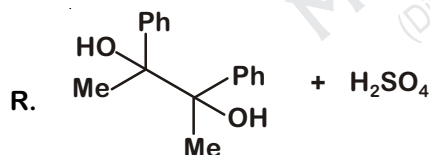
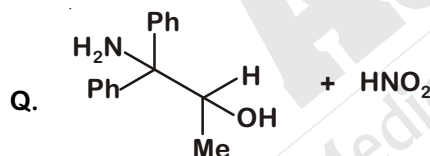
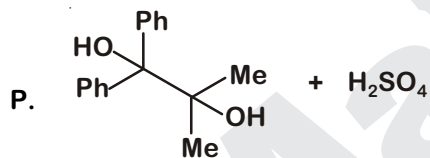

List-II

1. I_2, NaOH

2. $[\text{Ag}(\text{NH}_3)_2]\text{OH}$

3. Fehling solution

4. HCHO, NaOH

5. NaOBr

The correct option is

(A) $\text{P} \rightarrow 1; \text{Q} \rightarrow 2,3; \text{R} \rightarrow 1,4; \text{S} \rightarrow 2,4$

(B) $\text{P} \rightarrow 1,5; \text{Q} \rightarrow 3,4; \text{R} \rightarrow 4,5; \text{S} \rightarrow 3$

(C) $\text{P} \rightarrow 1,5; \text{Q} \rightarrow 3,4; \text{R} \rightarrow 5; \text{S} \rightarrow 2,4$

(D) $\text{P} \rightarrow 1,5; \text{Q} \rightarrow 2,3; \text{R} \rightarrow 1,5; \text{S} \rightarrow 2,3$

Answer (D)

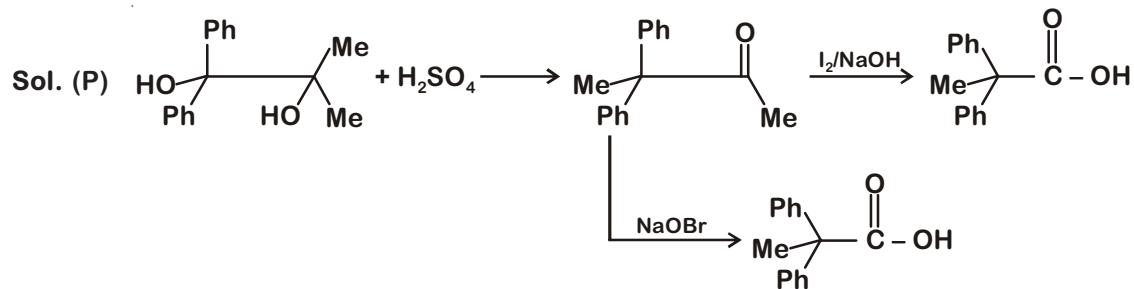

P → 1, 5

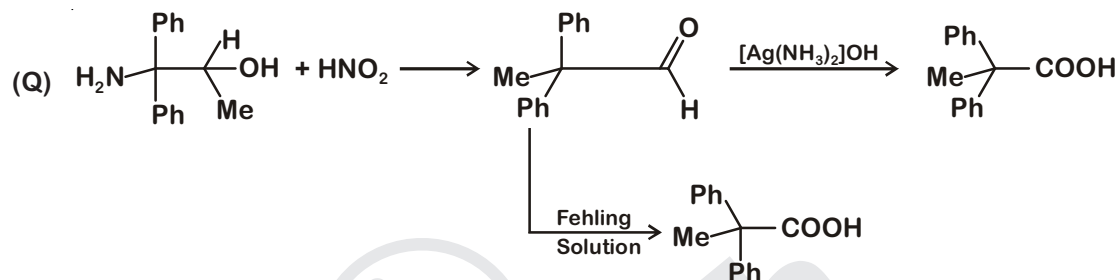

Q → 2, 3

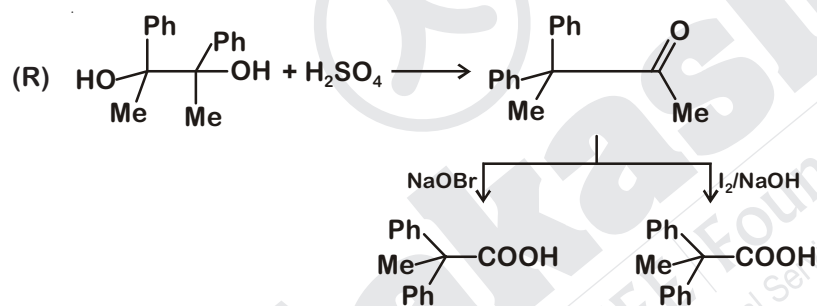

R → 1, 5

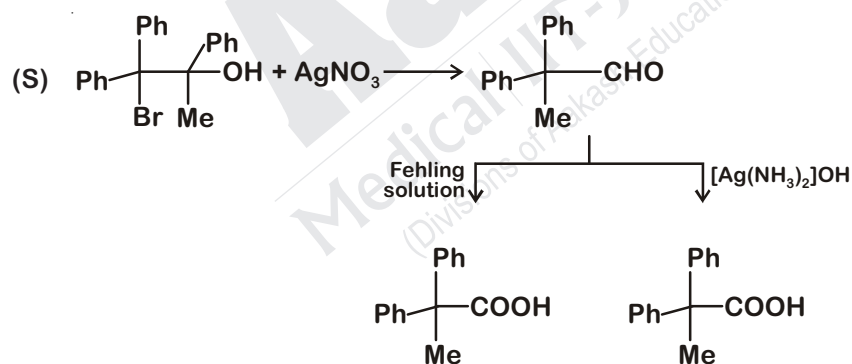

S → 2, 3

17. LIST-I contains reactions and LIST-II contains major products.

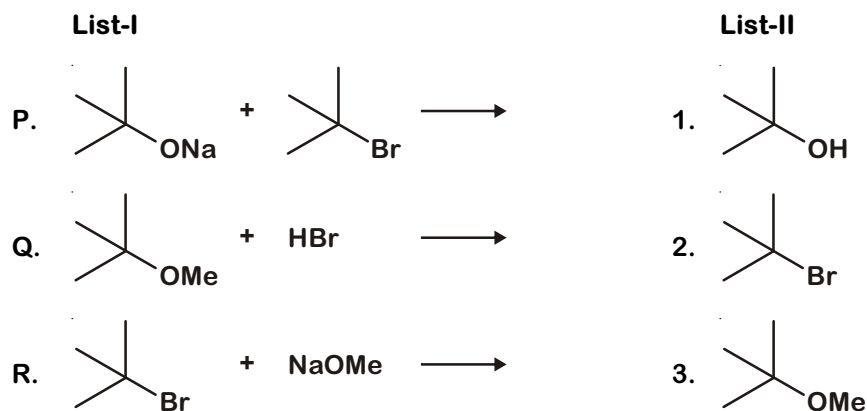

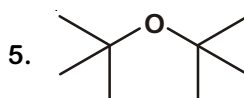
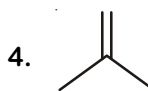
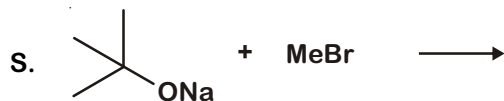

Match each reaction in LIST-I with one or more products in LIST-II and choose the correct option.

- (A) P \rightarrow 1,5; Q \rightarrow 2; R \rightarrow 3; S \rightarrow 4
 (B) P \rightarrow 1,4; Q \rightarrow 2; R \rightarrow 4; S \rightarrow 3
 (C) P \rightarrow 1,4; Q \rightarrow 1,2; R \rightarrow 3,4; S \rightarrow 4
 (D) P \rightarrow 4,5; Q \rightarrow 4; R \rightarrow 4; S \rightarrow 3,4

Answer (B)

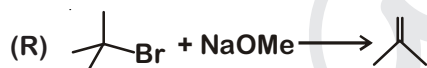
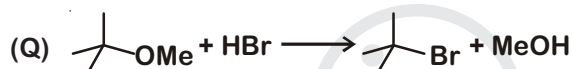
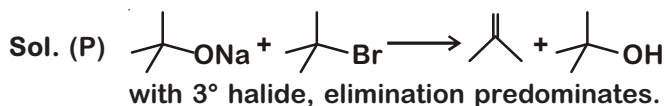

P \rightarrow 1, 4; Q \rightarrow 2; R \rightarrow 4; S \rightarrow 3.

18. Dilution processes of different aqueous solutions, with water, are given in LIST-I. The effects of dilution of the solutions on $[H^+]$ are given in LIST-II.

(Note: Degree of dissociation (α) of weak acid and weak base is $\ll 1$; degree of hydrolysis of salt $\ll 1$; $[H^+]$ represents the concentration of H^+ ions)

List-I

- P. (10 mL of 0.1 M NaOH + 20 mL of 0.1 M acetic acid) diluted to 60 mL
 Q. (20 mL of 0.1 M NaOH + 20 mL of 0.1 M acetic acid) diluted to 80 mL
 R. (20 mL of 0.1 M HCl + 20 mL of 0.1 M ammonia solution) diluted to 80 mL
 S. 10 mL saturated solution of $Ni(OH)_2$ in equilibrium with excess solid $Ni(OH)_2$ is diluted to 20 mL (solid $Ni(OH)_2$ is still present after dilution).

List-II

1. the value of $[H^+]$ does not change on dilution
 2. the value of $[H^+]$ changes to half of its initial value on dilution
 3. the value of $[H^+]$ changes to two times of its initial value on dilution
 4. the value of $[H^+]$ changes to $\frac{1}{\sqrt{2}}$ times of its initial value on dilution
 5. the value of $[H^+]$ changes to $\sqrt{2}$ times of its initial value on dilution

Match each process given in LIST-I with one or more effect(s) in LIST-II. The correct option is

- (A) P \rightarrow 4; Q \rightarrow 2; R \rightarrow 3; S \rightarrow 1
 (B) P \rightarrow 4; Q \rightarrow 3; R \rightarrow 2; S \rightarrow 3
 (C) P \rightarrow 1; Q \rightarrow 4; R \rightarrow 5; S \rightarrow 3
 (D) P \rightarrow 1; Q \rightarrow 5; R \rightarrow 4; S \rightarrow 1

Answer (D)

Sol. (P) $[\text{CH}_3\text{COOH}]_{\text{old}} = \frac{20 \times 0.1 - 10 \times 0.1}{30} = \frac{1}{30}$

$$[\text{CH}_3\text{COO}^-]_{\text{old}} = \frac{1}{30}$$

Buffer with [Salt] = [Acid]

pH does not change on dilution (P) \rightarrow (1)

(Q) $[\text{CH}_3\text{COO}^-]_{\text{old}} = \frac{20 \times 0.1}{40} = \frac{2}{40}$

$$[\text{CH}_3\text{COO}^-]_{\text{new}} = \frac{2}{80}$$

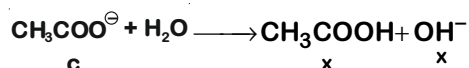

$$K_h = \frac{x^2}{c} = \frac{[\text{OH}^-]_{\text{old}}^2}{2/40} = \frac{[\text{OH}^-]_{\text{new}}^2}{2/80}$$

$$\Rightarrow [\text{OH}^-]_{\text{new}}^2 = \frac{[\text{OH}^-]_{\text{old}}^2}{2}$$

$$\Rightarrow [\text{OH}^-]_{\text{new}} = \frac{[\text{OH}^-]_{\text{old}}}{\sqrt{2}}$$

$$\therefore [\text{H}^+]_{\text{new}} = \sqrt{2}[\text{H}^+]_{\text{old}}$$

(Q) \rightarrow (5)

(R) $[\text{NH}_4^+]_{\text{old}} = \frac{20 \times 0.1}{40} = \frac{2}{40}$

$$[\text{NH}_4^+]_{\text{new}} = \frac{2}{80}$$

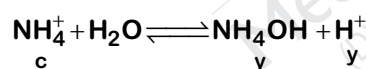

$$K_h = \frac{y^2}{c} = \frac{[\text{H}^+]_{\text{old}}^2}{(2/40)} = \frac{[\text{H}^+]_{\text{new}}^2}{(2/80)}$$

$$\Rightarrow [\text{H}^+]_{\text{new}}^2 = \frac{[\text{H}^+]_{\text{old}}^2}{2}$$

$$[\text{H}^+]_{\text{new}} = \frac{[\text{H}^+]_{\text{old}}}{\sqrt{2}}$$

(R) \rightarrow (4)

(S) For a saturated solution, $[\text{OH}^-] = \sqrt[3]{2K_{\text{sp}}}$

irrespective of volume of solution. $[\text{H}^+]$ remains constant.

(S) \rightarrow (1)

END OF CHEMISTRY

PART-III : MATHEMATICS

SECTION 1 (Maximum Marks : 24)

- This section contains **SIX (06)** questions.
- Each question has **FOUR** options for correct answer(s). **ONE OR MORE THAN ONE** of these four option(s) is (are) correct option(s).
- For each question, choose the correct option(s) to answer the question.
- Answer to each question will be evaluated according to the following marking scheme:

Full Marks : +4 If only (all) the correct option(s) is (are) chosen.

Partial Marks : +3 If all the four options are correct but **ONLY** three options are chosen.

Partial Marks : +2 If three or more options are correct but **ONLY** two options are chosen, both of which are correct options.

Partial Marks : +1 If two or more options are correct but **ONLY** one option is chosen and it is a correct option.

Zero Marks : 0 If none of the options is chosen (i.e. the question is unanswered).

Negative Marks : -2 In all other cases.

For Example: If first, third and fourth are the **ONLY** three correct options for a question with second option being an incorrect option; selecting only all the three correct options will result in +4 marks. Selecting only two of the three correct options (e.g. the first and fourth options), without selecting any incorrect option (second option in this case), will result in +2 marks. Selecting only one of the three correct options (either first or third or fourth option), without selecting any incorrect option (second option in this case), will result in +1 marks. Selecting any incorrect option(s) (second option in this case), with or without selection of any correct option(s) will result in -2 marks.

1. For any positive integer n , define $f_n : (0, \infty) \rightarrow \mathbb{R}$ as

$$f_n(x) = \sum_{j=1}^n \tan^{-1} \left(\frac{1}{1+(x+j)(x+j-1)} \right) \text{ for all } x \in (0, \infty)$$

(Here, the inverse trigonometric function $\tan^{-1}x$ assumes values in $\left(-\frac{\pi}{2}, \frac{\pi}{2}\right)$.)

Then, which of the following statement(s) is (are) TRUE?

(A) $\sum_{j=1}^5 \tan^2(f_j(0)) = 55$

(B) $\sum_{j=1}^{10} (1+f'_j(0)) \sec^2(f_j(0)) = 10$

(C) For any fixed positive integer n , $\lim_{x \rightarrow \infty} \tan(f_n(x)) = \frac{1}{n}$

(D) For any fixed positive integer n , $\lim_{x \rightarrow \infty} \sec^2(f_n(x)) = 1$

Answer (D)

Sol. $f_n(x) = \tan^{-1}(n+x) - \tan^{-1}(x) = \tan^{-1} \left(\frac{n}{1+(n+x)x} \right)$

$$f'_n(x) = \frac{1}{1+(n+x)^2} - \frac{1}{1+x^2}$$

- (A) $x = 0$ is not in domain
 (B) $x = 0$ is not in domain
 (C) $\lim_{x \rightarrow \infty} \tan(f_n(x)) = \lim_{x \rightarrow \infty} \frac{n}{1+(n+x)x} = 0$
 (D) $\lim_{x \rightarrow \infty} (1 + \tan^2(f_n(x))) = 1 + 0 = 1$

2. Let T be the line passing through the points $P(-2, 7)$ and $Q(2, -5)$. Let F_1 be the set of all pairs of circles (S_1, S_2) such that T is tangent to S_1 at P and tangent to S_2 at Q , and also such that S_1 and S_2 touch each other at a point, say, M . Let E_1 be the set representing the locus of M as the pair (S_1, S_2) varies in F_1 . Let the set of all straight line segments joining a pair of distinct points of E_1 and passing through the point $R(1, 1)$ be F_2 . Let E_2 be the set of the mid-points of the line segments in the set F_2 . Then, which of the following statement(s) is (are) TRUE?
- (A) The point $(-2, 7)$ lies in E_1
 (B) The point $(\frac{4}{5}, \frac{7}{5})$ does NOT lie in E_2
 (C) The point $(\frac{1}{2}, 1)$ lies in E_2
 (D) The point $(0, \frac{3}{2})$ does NOT lie in E_1

Answer (B, D)

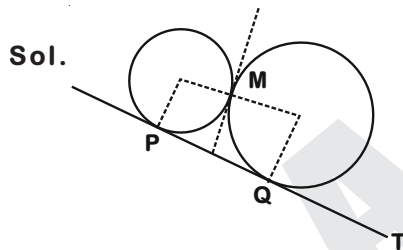

$\angle PMQ = 90^\circ$
 $\Rightarrow \frac{\beta+5}{\alpha-2} \times \frac{\beta-7}{\alpha+2} = -1$

Locus of M

$x^2 + y^2 - 2y - 39 = 0$... (1)

Equation of chord of circle whose midpoint is (α, β) is

$S_1 = T$
 $\Rightarrow x\alpha + y\beta - (y + \beta) - 39 = \alpha^2 + \beta^2 - 2\beta - 39$

It passes through $(1, 1)$
 $\Rightarrow \alpha^2 + \beta^2 - 2\beta - \alpha + 1 = 0$

Locus : $x^2 + y^2 - x - 2y + 1 = 0$... (2)

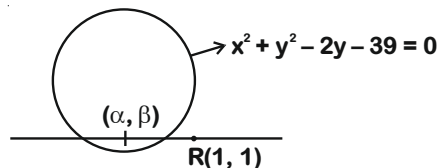

Option (A) is incorrect although it satisfies eq. (1) otherwise the line T would touch the second circle on two points. Also $(\frac{4}{5}, \frac{7}{5})$ satisfies eq. (2) but again in this case one end of the chord would be

$(-2, 7)$ which is not included in E_1 . Therefore $(\frac{4}{5}, \frac{7}{5})$ does not lie in E_2 . $(\frac{1}{2}, 1)$ does not satisfy equation (2), therefore it does not lie in E_2 . $(0, \frac{3}{2})$ does not satisfy (1), so does not lie in E_1 .

3. Let S be the set of all column matrices $\begin{bmatrix} b_1 \\ b_2 \\ b_3 \end{bmatrix}$ such that $b_1, b_2, b_3 \in \mathbb{R}$ and the system of equations (in real variables)

$$-x + 2y + 5z = b_1$$

$$2x - 4y + 3z = b_2$$

$$x - 2y + 2z = b_3$$

has at least one solution. Then, which of the following system(s) (in real variables) has (have) at least

one solution for each $\begin{bmatrix} b_1 \\ b_2 \\ b_3 \end{bmatrix} \in S$?

- (A) $x + 2y + 3z = b_1, 4y + 5z = b_2$ and $x + 2y + 6z = b_3$
- (B) $x + y + 3z = b_1, 5x + 2y + 6z = b_2$ and $-2x - y - 3z = b_3$
- (C) $-x + 2y - 5z = b_1, 2x - 4y + 10z = b_2$ and $x - 2y + 5z = b_3$
- (D) $x + 2y + 5z = b_1, 2x + 3z = b_2$ and $x + 4y - 5z = b_3$

Answer (A, D)

Sol. Given system of equations can be written as

$$\begin{bmatrix} -1 & 2 & 5 \\ 2 & -4 & 3 \\ 1 & -2 & 2 \end{bmatrix} \begin{bmatrix} x \\ y \\ z \end{bmatrix} = \begin{bmatrix} b_1 \\ b_2 \\ b_3 \end{bmatrix} \Rightarrow AX = B$$

$$[A|B] = \left[\begin{array}{ccc|c} -1 & 2 & 5 & b_1 \\ 2 & -4 & 3 & b_2 \\ 1 & -2 & 2 & b_3 \end{array} \right] \sim \left[\begin{array}{ccc|c} -1 & 2 & 5 & b_1 \\ 0 & 0 & 6 & b_1 + b_2 - b_3 \\ 0 & 0 & 7 & b_1 + b_3 \end{array} \right] \sim \left[\begin{array}{ccc|c} -1 & 2 & 5 & b_1 \\ 0 & 0 & 0 & \frac{1}{7}b_1 + b_2 - \frac{13}{7}b_3 \\ 0 & 0 & 7 & b_1 + b_3 \end{array} \right]$$

For solution of this system, $\frac{b_1}{7} + b_2 - \frac{13b_3}{7} = 0$

$$\Rightarrow b_1 + 7b_2 - 13b_3 = 0 \Rightarrow (b_1, b_2, b_3) = (-7K_2 + 13K_3, K_2, K_3) \text{ where } K_2, K_3 \in \mathbb{R} \quad \dots(i)$$

(A) $\Delta \neq 0 \Rightarrow$ any possible set of (b_1, b_2, b_3) would give a solution.

\Rightarrow every set of values of (i) provides atleast a solution of system of option (A).

$$(B) \left[\begin{array}{ccc|c} 1 & 1 & 3 & b_1 \\ 5 & 2 & 6 & b_2 \\ -2 & -1 & -3 & b_3 \end{array} \right] \sim \left[\begin{array}{ccc|c} 1 & 1 & 3 & b_1 \\ 3 & 0 & 0 & -2b_1 + b_2 \\ -1 & 0 & 0 & b_1 + b_3 \end{array} \right] \sim \left[\begin{array}{ccc|c} 1 & 1 & 3 & b_1 \\ 0 & 0 & 0 & b_1 + b_2 + 3b_3 \\ -1 & 0 & 0 & b_1 + b_3 \end{array} \right]$$

For solution of this system, $b_1 + b_2 + 3b_3 = 0$

$$\Rightarrow (b_1, b_2, b_3) = (-K_2 - 3K_3, K_2, K_3), K_2, K_3 \in \mathbb{R} \dots(ii)$$

Obviously, the set represented by (i) is not contained in (ii).

\Rightarrow This system doesn't have solution for every set of (b_1, b_2, b_3) of (i).

(C) Equations are of parallel planes or identical planes. For solution, these planes should be identical for that, $(b_1, b_2, b_3) = (-K_3, 2K_3, K_3) \dots(iii)$

Every such value of (b_1, b_2, b_3) is contained in (i) but not every value of (b_1, b_2, b_3) of (i) is present in (iii).

\Rightarrow Not every (b_1, b_2, b_3) of (i) gives solution to the system of equations of option (C).

(D) $\Delta \neq 0 \Rightarrow$ every set of values of (i) provides atleast a solution of system of option (D).

4. Consider two straight lines, each of which is tangent to both the circle $x^2 + y^2 = \frac{1}{2}$ and the parabola $y^2 = 4x$. Let these lines intersect at the point Q. Consider the ellipse whose center is at the origin O(0,0) and whose semi-major axis is OQ. If the length of the minor axis of this ellipse is $\sqrt{2}$, then which of the following statement(s) is (are) TRUE?

(A) For the ellipse, the eccentricity is $\frac{1}{\sqrt{2}}$ and the length of the latus rectum is 1

(B) For the ellipse, the eccentricity is $\frac{1}{2}$ and the length of the latus rectum is $\frac{1}{2}$

(C) The area of the region bounded by the ellipse between the lines $x = \frac{1}{\sqrt{2}}$ and $x = 1$ is $\frac{1}{4\sqrt{2}}(\pi - 2)$

(D) The area of the region bounded by the ellipse between the lines $x = \frac{1}{\sqrt{2}}$ and $x = 1$ is $\frac{1}{16}(\pi - 2)$

Answer (A, C)

Sol. $y = mx + \frac{1}{m}$ is also tangent to $x^2 + y^2 = \frac{1}{2}$

$$\Rightarrow \frac{\left| \frac{1}{m} \right|}{\sqrt{1+m^2}} = \frac{1}{\sqrt{2}} \Rightarrow m = \pm 1$$

Common tangents are $y = x + 1$ and $y = -x - 1 \Rightarrow Q(-1, 0)$

Equation of ellipse is $\frac{x^2}{1^2} + \frac{y^2}{\left(\frac{1}{\sqrt{2}}\right)^2} = 1$

$$b^2 = a^2(1 - e^2)$$

$$\Rightarrow \frac{1}{2} = 1(1 - e^2) \Rightarrow e = \frac{1}{\sqrt{2}}$$

$$\text{Length of latus rectum} = \frac{2b^2}{a} = \frac{2 \times \frac{1}{2}}{1} = 1$$

$$y = \pm \frac{1}{\sqrt{2}} \sqrt{1 - x^2}$$

$$A = 2 \times \frac{1}{\sqrt{2}} \int_{\frac{1}{\sqrt{2}}}^1 \sqrt{1 - x^2} dx$$

$$= \sqrt{2} \left[\frac{1}{2} x \sqrt{1 - x^2} + \frac{1}{2} \sin^{-1} x \right]_{\frac{1}{\sqrt{2}}}^1$$

$$= \frac{\pi - 2}{4\sqrt{2}} \text{ sq. units}$$

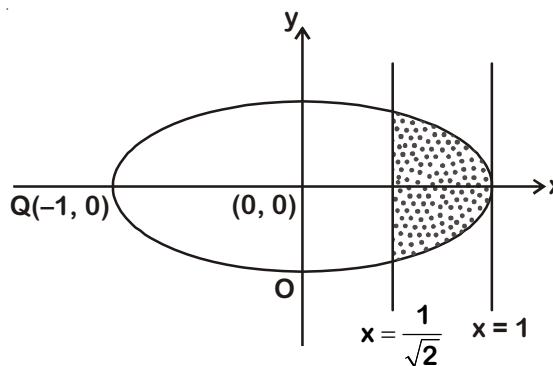

5. Let s, t, r be non-zero complex numbers and L be the set of solutions $z = x + iy$ ($x, y \in \mathbb{R}, i = \sqrt{-1}$) of the equation $sz + t\bar{z} + r = 0$, where $\bar{z} = x - iy$. Then, which of the following statement(s) is (are) TRUE?
- (A) If L has exactly one element, then $|s| \neq |t|$
 (B) If $|s| = |t|$, then L has infinitely many elements
 (C) The number of elements in $L \cap \{z : |z - 1 + i| = 5\}$ is at most 2
 (D) If L has more than one element, then L has infinitely many elements

Answer (A, C, D)

Sol. $sz + t\bar{z} + r = 0 \quad \dots(i)$

Taking conjugate of (i)

$$\bar{s}\bar{z} + \bar{t}z + \bar{r} = 0 \quad \dots(ii)$$

Eliminating \bar{z} from (i) and (ii)

$$(s\bar{s}z + t\bar{s}\bar{z} + \bar{s}r) - (t\bar{s}\bar{z} + \bar{t}tz + t\bar{r}) = 0$$

$$z(|s|^2 - |t|^2) = t\bar{r} - r\bar{s}$$

- (A) If $|s| \neq |t|$, then z has unique value
 (B) If $|s| = |t|$ and $\bar{r}t - r\bar{s} = 0$, then z has infinitely many values
 If $|s| = |t|$ and $\bar{r}t - r\bar{s} \neq 0$, then z has no value
 $\Rightarrow L$ may be empty set or infinite set
 (C) Locus of z is null set or singleton set or a line in all cases. It will intersect given circle at most two points.
 (D) If L has more than one element, then L has infinite elements.
6. Let $f : (0, \pi) \rightarrow \mathbb{R}$ be a twice differentiable function such that

$$\lim_{t \rightarrow x} \frac{f(x)\sin t - f(t)\sin x}{t - x} = \sin^2 x \text{ for } x \in (0, \pi).$$

If $f\left(\frac{\pi}{6}\right) = -\frac{\pi}{12}$, then which of the following statement(s) is (are) TRUE?

- (A) $f\left(\frac{\pi}{4}\right) = \frac{\pi}{4\sqrt{2}}$
 (B) $f(x) < \frac{x^4}{6} - x^2$ for all $x \in (0, \pi)$
 (C) There exists $\alpha \in (0, \pi)$ such that $f'(\alpha) = 0$
 (D) $f''\left(\frac{\pi}{2}\right) + f\left(\frac{\pi}{2}\right) = 0$

Answer (B, C, D)

Sol. $\lim_{t \rightarrow x} \frac{f(x)\sin t - f(t)\sin x}{t - x} = \sin^2 x$

Using L.H. rule and N.L. theorem,

$$f(x)\cos x - f'(x)\sin x = \sin^2 x$$

$$f(x) \cdot \frac{1}{\sin x} = -x + c \quad \dots(i)$$

$$\therefore f\left(\frac{\pi}{6}\right) = -\frac{\pi}{12} \Rightarrow c = 0 \Rightarrow f(x) = -x \sin x$$

$$(A) f\left(\frac{\pi}{4}\right) = -\frac{\pi}{4\sqrt{2}}$$

$$(B) \text{ As } \sin x > x - \frac{x^3}{6}$$

$$\Rightarrow -x \sin x < -x^2 + \frac{x^4}{6}$$

$$\Rightarrow f(x) < -x^2 + \frac{x^4}{6}$$

$$(C) \because f(x) \text{ is continuous in } [0, \pi] \text{ and differentiable in } (0, \pi) \text{ and } f(0) = f(\pi) = 0$$

$$\Rightarrow f'(\alpha) = 0, \alpha \in (0, \pi)$$

$$(D) f'(x) = -x \cos x - \sin x, f''(x) = x \sin x - 2 \cos x$$

$$f''\left(\frac{\pi}{2}\right) + f\left(\frac{\pi}{2}\right) = \frac{\pi}{2} - \frac{\pi}{2} = 0$$

SECTION 2 (Maximum Marks : 24)

- This section contains **EIGHT (08)** questions. The answer to each question is a **NUMERICAL VALUE**.
- For each question, enter the correct numerical value (in decimal notation, truncated/rounded-off to the **second decimal place**; e.g. 6.25, 7.00, -0.33, -.30, 30.27, -127.30) using the mouse and the on-screen virtual numeric keypad in the place designated to enter the answer.
- Answer to each question will be evaluated according to the following marking scheme:

Full Marks : +3 If **ONLY** the correct numerical value is entered as answer.

Zero Marks : 0 In all other cases.

7. The value of the integral $\int_0^{\frac{1}{2}} \frac{1 + \sqrt{3}}{\left((x+1)^2(1-x)^6\right)^{\frac{1}{4}}} dx$ is ____.

Answer (2.00)

$$\text{Sol. } I = \int_0^{\frac{1}{2}} \frac{1 + \sqrt{3}}{\left((x+1)^2(1-x)^6\right)^{\frac{1}{4}}} dx = \int_0^{\frac{1}{2}} \frac{1 + \sqrt{3}}{\left((x+1)^8 \left(\frac{1-x}{1+x}\right)^6\right)^{\frac{1}{4}}} dx = \int_0^{\frac{1}{2}} \frac{1 + \sqrt{3}}{(1+x)^2 \left(\frac{1-x}{1+x}\right)^{\frac{3}{2}}} dx$$

$$\text{Put } \frac{1-x}{1+x} = t \Rightarrow \frac{-2dx}{(1+x)^2} = dt$$

$$\Rightarrow I = -\frac{1}{2} \int_1^{\frac{1+\sqrt{3}}{2}} \frac{1 + \sqrt{3}}{t^{\frac{3}{2}}} = -\frac{1}{2} \times (1 + \sqrt{3}) \left[\frac{t^{-1/2}}{-\frac{1}{2}} \right]_1^{\frac{1+\sqrt{3}}{2}} = (1 + \sqrt{3})(\sqrt{3} - 1) = 2$$

8. Let P be a matrix of order 3×3 such that all the entries in P are from the set $\{-1, 0, 1\}$. Then, the maximum possible value of the determinant of P is ____.

Answer (4.00)

$$\text{Sol. } P = \begin{bmatrix} a_{11} & a_{12} & a_{13} \\ a_{21} & a_{22} & a_{23} \\ a_{31} & a_{32} & a_{33} \end{bmatrix}$$

The maximum possibility of $|P|$ can be 6 if

$$\begin{vmatrix} a_{21} & a_{22} \\ a_{31} & a_{32} \end{vmatrix} = \pm 2 = \pm \begin{vmatrix} a_{22} & a_{23} \\ a_{32} & a_{33} \end{vmatrix} = \pm \begin{vmatrix} a_{21} & a_{23} \\ a_{31} & a_{33} \end{vmatrix}$$

but, the moment $\begin{vmatrix} a_{21} & a_{22} \\ a_{31} & a_{32} \end{vmatrix}$ is set as 2 (say) and $\begin{vmatrix} a_{22} & a_{23} \\ a_{32} & a_{33} \end{vmatrix}$ as 2 or -2 , automatically $\begin{vmatrix} a_{21} & a_{23} \\ a_{31} & a_{33} \end{vmatrix}$ takes zero.

Hence, $|P| \neq 6$. Next possibility is 4.

$$P = \begin{bmatrix} 1 & -1 & -1 \\ -1 & 1 & -1 \\ 1 & 1 & 1 \end{bmatrix} \text{ is one such possibility.}$$

9. Let X be a set with exactly 5 elements and Y be a set with exactly 7 elements. If α is the number of one-one functions from X to Y and β is the number of onto functions from Y to X , then the value of $\frac{1}{5!}(\beta - \alpha)$ is ____.

Answer (119.00)

Sol. α = Number of one-one functions from X to Y

β = Number of onto functions from Y to X

= Make 5 groups out of 7 elements of Y and permute these groups to 5 elements of X

$$= \frac{7!}{3!(1!)^4 \cdot 4!} \times 5! + \frac{7!}{(2!)^2 (1!)^3 \cdot 2! \cdot 3!} \times 5!$$

$$\Rightarrow \frac{1}{5!}(\beta - \alpha) = \frac{7!}{3! \cdot 4!} + \frac{7!}{(2!)^3 \cdot 3!} - \frac{7!}{5! \cdot 2!}$$

$$= 7 [5 + 15 - 3] = 119$$

10. Let $f: \mathbb{R} \rightarrow \mathbb{R}$ be a differentiable function with $f(0) = 0$. If $y = f(x)$ satisfies the differential equation

$$\frac{dy}{dx} = (2+5y)(5y-2), \text{ then the value of } \lim_{x \rightarrow -\infty} f(x) \text{ is ____}.$$

Answer (0.40)

$$\text{Sol. } \frac{dy}{dx} = (2+5y)(5y-2)$$

$$\Rightarrow \int \frac{dy}{(5y+2)(5y-2)} = \int dx$$

$$\Rightarrow \frac{1}{4} \int \left(\frac{1}{5y-2} - \frac{1}{5y+2} \right) dy = \int dx$$

$$\Rightarrow \frac{1}{20} \ln \left| \frac{5y-2}{5y+2} \right| = x + C$$

$$f(0) = 0 \Rightarrow \ln \left| \frac{5y-2}{5y+2} \right| = x$$

$$x \rightarrow -\infty \Rightarrow \ln \left| \frac{5y-2}{5y+2} \right| \rightarrow -\infty$$

$$\Rightarrow \left| \frac{5y-2}{5y+2} \right| \rightarrow 0 \Rightarrow y \rightarrow \frac{2}{5}$$

$$\therefore \lim_{x \rightarrow -\infty} f(x) = \frac{2}{5} = 0.40$$

11. Let $f: \mathbb{R} \rightarrow \mathbb{R}$ be a differentiable function with $f(0) = 1$ and satisfying the equation $f(x+y) = f(x)f'(y) + f'(x)f(y)$ for all $x, y \in \mathbb{R}$. Then, the value of $\log_e(f(4))$ is _____.

Answer (2.00)

Solution :

$$f(0) = 1, f: \mathbb{R} \rightarrow \mathbb{R}$$

$$f(x+y) = f(x)f'(y) + f'(x)f(y) \quad \forall x, y \in \mathbb{R}$$

$$\text{Put } x = y = 0 \Rightarrow f(0) = 2f(0)f'(0) \Rightarrow f'(0) = 1/2$$

$$\text{Put } y = 0,$$

$$f(x) = f(x)f'(0) + f'(x)f(0)$$

$$\Rightarrow f(x) = \frac{1}{2}f(x) + f'(x)$$

$$\Rightarrow \frac{f'(x)}{f(x)} = \frac{1}{2} \Rightarrow \ln(f(x)) = \frac{x}{2} + C$$

$$f(0) = 1 \Rightarrow C = 0$$

$$\Rightarrow \ln(f(x)) = \frac{x}{2}$$

$$\therefore \ln(f(4)) = \frac{4}{2} = 2$$

12. Let P be a point in the first octant, whose image Q in the plane $x + y = 3$ (that is, the line segment PQ is perpendicular to the plane $x + y = 3$ and the mid-point of PQ lies in the plane $x + y = 3$) lies on the z-axis. Let the distance of P from the x-axis be 5. If R is the image of P in the xy-plane, then the length of PR is _____.

Answer (8.00)

Sol. $P = (\alpha, \beta, \gamma)$, $Q = (0, 0, K)$ as it lies on z-axis

$$\text{mid point of PQ, i.e., } \left(\frac{\alpha}{2}, \frac{\beta}{2}, \frac{\gamma+K}{2} \right) \text{ satisfies}$$

$$x + y = 3$$

$$\Rightarrow \alpha + \beta = 6 \quad \dots(1)$$

$$\text{d.r. of PQ} = (\alpha - 0, \beta - 0, \gamma - K) = (p, p, 0)$$

$$\Rightarrow \alpha = \beta \text{ \& } \gamma = K \quad \dots(2)$$

$$\therefore (1) \text{ \& } (2) \Rightarrow \alpha = \beta = 3$$

$$\therefore P = (\alpha, \alpha, K) = (3, 3, K)$$

$$\text{distance of P from x-axis} = 5$$

$$\Rightarrow \beta^2 + \gamma^2 = 25 \Rightarrow \alpha^2 + K^2 = 25 \Rightarrow 3^2 + K^2 = 25$$

$$\Rightarrow |K| = 4$$

$$\text{Length of PR} = 2|K| = 8$$

13. Consider the cube in the first octant with sides OP, OQ and OR of length 1, along the x-axis, y-axis and z-axis, respectively, where O(0, 0, 0) is the origin. Let $S\left(\frac{1}{2}, \frac{1}{2}, \frac{1}{2}\right)$ be the centre of the cube and T be the vertex of the cube opposite to the origin O such that S lies on the diagonal OT. If $\vec{p} = \vec{SP}$, $\vec{q} = \vec{SQ}$, $\vec{r} = \vec{SR}$ and $\vec{t} = \vec{ST}$, then the value of $|(\vec{p} \times \vec{q}) \times (\vec{r} \times \vec{t})|$ is _____.

Answer (0.50)

Sol. $\vec{p} = \vec{SP} = \frac{1}{2}\hat{i} - \frac{1}{2}\hat{j} - \frac{1}{2}\hat{k} = \frac{1}{2}(\hat{i} - \hat{j} - \hat{k})$

$$\vec{q} = \vec{SQ} = \frac{1}{2}(-\hat{i} + \hat{j} - \hat{k})$$

$$\vec{r} = \vec{SR} = \frac{1}{2}(-\hat{i} - \hat{j} + \hat{k})$$

$$\vec{t} = \vec{ST} = \frac{1}{2}(\hat{i} + \hat{j} + \hat{k})$$

$$\vec{p} \times \vec{q} = \frac{1}{4} \begin{vmatrix} \hat{i} & \hat{j} & \hat{k} \\ 1 & -1 & -1 \\ -1 & 1 & -1 \end{vmatrix} = \frac{1}{2}(\hat{i} + \hat{j})$$

$$\vec{r} \times \vec{t} = \frac{1}{4} \begin{vmatrix} \hat{i} & \hat{j} & \hat{k} \\ -1 & -1 & 1 \\ 1 & 1 & 1 \end{vmatrix} = \frac{1}{4} \begin{vmatrix} \hat{i} & \hat{j} & \hat{k} \\ -1 & -1 & 1 \\ 0 & 0 & 2 \end{vmatrix} = \frac{1}{2}(-\hat{i} + \hat{j})$$

$$(\vec{p} \times \vec{q}) \times (\vec{r} \times \vec{t}) = \frac{1}{4}((\hat{i} + \hat{j}) \times (-\hat{i} + \hat{j})) = \frac{1}{4} \times 2\hat{k} = \frac{1}{2}\hat{k}$$

$$|(\vec{p} \times \vec{q}) \times (\vec{r} \times \vec{t})| = \frac{1}{2} = 0.50$$

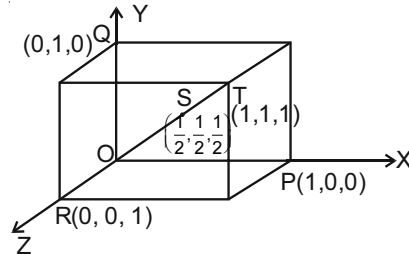

14. Let $X = ({}^{10}C_1)^2 + 2({}^{10}C_2)^2 + 3({}^{10}C_3)^2 + \dots + 10({}^{10}C_{10})^2$, where ${}^{10}C_r$, $r \in \{1, 2, \dots, 10\}$ denote binomial coefficients. Then, the value of $\frac{1}{1430}X$ is _____.

Answer (646.00)

Sol. $(1+x)^{10} = {}^{10}C_0 + {}^{10}C_1x + {}^{10}C_2x^2 + \dots + {}^{10}C_{10}x^{10}$

differentiate both sides w.r.t x,

$$10(1+x)^9 = {}^{10}C_1 + 2 \cdot {}^{10}C_2x + 3 \cdot {}^{10}C_3x^2 + \dots + 10 \cdot {}^{10}C_{10}x^9 \quad \dots(1)$$

$$(1+x)^{10} = {}^{10}C_0x^{10} + {}^{10}C_1x^9 + \dots + {}^{10}C_{10} \quad \dots(2)$$

Coefficient of x^9 in $10(1+x)^9(1+x)^{10}$ is same

$$\text{as } ({}^{10}C_1)^2 + 2({}^{10}C_2)^2 + 3({}^{10}C_3)^2 + \dots + 10({}^{10}C_{10})^2$$

$$= \text{Coeff. of } x^9 \text{ in } 10(1+x)^{19} = 10 \times {}^{19}C_9 = X$$

$$\frac{1}{1430}X = \frac{1}{1430} \times 10 \times \frac{19 \times 18 \times 17 \times 16 \times 15 \times 14 \times 13 \times 12 \times 11}{9 \times 8 \times 7 \times 6 \times 5 \times 4 \times 3 \times 2} = 646$$

SECTION 3 (Maximum Marks : 12)

- This section contains **FOUR (04)** questions.
- Each question has **TWO (02)** matching lists: **LIST-I** and **LIST-II**.
- **FOUR** options are given representing matching of elements from **LIST-I** and **LIST-II**. **ONLY ONE** of these four options corresponds to a correct matching.
- For each question, choose the option corresponding to the correct matching.
- For each question, marks will be awarded according to the following marking scheme:
Full Marks : +3 If **ONLY** the option corresponding to the correct matching is chosen.
Zero Marks : 0 If none of the options is chosen (i.e. the question is unanswered).
Negative Marks : -1 In all other cases.

15. Let $E_1 = \left\{ x \in \mathbb{R} : x \neq 1 \text{ and } \frac{x}{x-1} > 0 \right\}$ and $E_2 = \left\{ x \in E_1 : \sin^{-1} \left(\log_e \left(\frac{x}{x-1} \right) \right) \text{ is a real number} \right\}$.

(Here, the inverse trigonometric function $\sin^{-1}x$ assumes value in $\left[-\frac{\pi}{2}, \frac{\pi}{2} \right]$.)

Let $f : E_1 \rightarrow \mathbb{R}$ be the function defined by $f(x) = \log_e \left(\frac{x}{x-1} \right)$

and $g : E_2 \rightarrow \mathbb{R}$ be the function defined by $g(x) = \sin^{-1} \left(\log_e \left(\frac{x}{x-1} \right) \right)$.

LIST-I

- P. The range of f is
- Q. The range of g contains
- R. The domain of f contains
- S. The domain of g is

LIST-II

1. $\left(-\infty, \frac{1}{1-e} \right] \cup \left[\frac{e}{e-1}, \infty \right)$
2. $(0, 1)$
3. $\left[-\frac{1}{2}, \frac{1}{2} \right]$
4. $(-\infty, 0) \cup (0, \infty)$
5. $\left(-\infty, \frac{e}{e-1} \right]$
6. $(-\infty, 0) \cup \left(\frac{1}{2}, \frac{e}{e-1} \right]$

The correct option is:

- (A) $P \rightarrow 4; Q \rightarrow 2; R \rightarrow 1; S \rightarrow 1$
- (B) $P \rightarrow 3; Q \rightarrow 3; R \rightarrow 6; S \rightarrow 5$
- (C) $P \rightarrow 4; Q \rightarrow 2; R \rightarrow 1; S \rightarrow 6$
- (D) $P \rightarrow 4; Q \rightarrow 3; R \rightarrow 6; S \rightarrow 5$

Answer (A)

Sol. For domain of $f(x)$;

$$\frac{x}{x-1} > 0 \Rightarrow x < 0 \text{ or } x > 1$$

$$D_f : (-\infty, 0) \cup (1, \infty) \supset \left(-\infty, \frac{1}{1-e}\right] \cup \left[\frac{e}{e-1}, \infty\right)$$

For range of $f(x)$;

$$\text{Let } y = \log_e \frac{x}{x-1} \Rightarrow x = \frac{e^y}{e^y - 1}$$

Now $x < 0$ or $x > 1$

$$\Rightarrow \frac{e^y}{e^y - 1} < 0 \quad \text{or} \quad \Rightarrow \frac{e^y}{e^y - 1} > 1$$

$$\Rightarrow 0 < e^y < 1 \quad \text{or} \quad \Rightarrow \frac{1}{e^y - 1} > 0$$

$$-\infty < y < 0 \quad \text{or} \quad \Rightarrow e^y > 0$$

Range of $f(x)$ is $(-\infty, 0) \cup (0, \infty)$

For domain of $g(x)$;

$$-1 \leq \log_e \left(\frac{x}{x-1}\right) \leq 1 \quad \text{and} \quad \frac{x}{x-1} > 0$$

$$\Rightarrow \frac{1}{e} \leq \frac{x}{x-1} \leq e \quad \text{and} \quad x < 0 \text{ or } x > 1$$

$$\Rightarrow \frac{x(e-1)+1}{x-1} \geq 0 \quad \text{and} \quad \frac{(e-1)x-e}{x-1} \geq 0 \quad \text{and} \quad x < 0 \text{ or } x > 1$$

$$\Rightarrow x \in \left(-\infty, -\frac{1}{e-1}\right] \cup \left[\frac{e}{e-1}, \infty\right)$$

For range of $g(x)$;

$$-1 \leq \log_e \left(\frac{x}{x-1}\right) < 0 \quad \text{or} \quad 0 < \log \left(\frac{x}{x-1}\right) \leq 1$$

$$\frac{-\pi}{2} \leq g(x) < 0 \quad \text{or} \quad 0 < g(x) \leq \frac{\pi}{2}$$

$$\Rightarrow \text{Range of } g(x) = \left[-\frac{\pi}{2}, 0\right) \cup \left(0, \frac{\pi}{2}\right]$$

$R \rightarrow 1, P \rightarrow 4, S \rightarrow 1, Q \rightarrow 2$

16. In a high school, a committee has to be formed from a group of 6 boys $M_1, M_2, M_3, M_4, M_5, M_6$ and 5 girls G_1, G_2, G_3, G_4, G_5 .
- Let α_1 be the total number of ways in which the committee can be formed such that the committee has 5 members, having exactly 3 boys and 2 girls.
 - Let α_2 be the total number of ways in which the committee can be formed such that the committee has at least 2 members, and having an equal number of boys and girls.
 - Let α_3 be the total number of ways in which the committee can be formed such that the committee has 5 members, at least 2 of them being girls.

- (iv) Let α_4 be the total number of ways in which the committee can be formed such that the committee has 4 members, having at least 2 girls and such that both M_1 and G_1 are NOT in the committee together.

LIST-I

- P. The value of α_1 is
Q. The value of α_2 is
R. The value of α_3 is
S. The value of α_4 is

LIST-II

1. 136
2. 189
3. 192
4. 200
5. 381
6. 461

The correct option is:

- (A) $P \rightarrow 4; Q \rightarrow 6; R \rightarrow 2; S \rightarrow 1$
(B) $P \rightarrow 1; Q \rightarrow 4; R \rightarrow 2; S \rightarrow 3$
(C) $P \rightarrow 4; Q \rightarrow 6; R \rightarrow 5; S \rightarrow 2$
(D) $P \rightarrow 4; Q \rightarrow 2; R \rightarrow 3; S \rightarrow 1$

Answer (C)

Solution :

(i) $\alpha_1 = {}^6C_3 \times {}^6C_2 = 20 \times 10 = 200$

(ii) $\alpha_2 = {}^6C_1 \times {}^5C_1 + {}^6C_2 \times {}^5C_2 + {}^6C_3 \times {}^5C_3 + {}^6C_4 \times {}^5C_4 + {}^6C_5 \times {}^5C_5$
 $= 30 + 150 + 200 + 75 + 6 = 461$

(iii) $\alpha_3 = {}^5C_2 \times {}^6C_3 + {}^5C_3 \times {}^6C_2 + {}^5C_4 \times {}^6C_1 + {}^5C_5$
 $= 200 + 150 + 30 + 1 = 381$

(iv) $\alpha_4 = ({}^5C_2 \times {}^6C_3 - {}^4C_1 \times {}^5C_1) + ({}^5C_3 \times {}^6C_1 - {}^4C_2 \times {}^5C_0)$
 $= (150 - 20) + (60 - 6) + 5$
 $= 130 + 60 - 1 = 190 - 1 = 189$

17. Let $H: \frac{x^2}{a^2} - \frac{y^2}{b^2} = 1$, where $a > b > 0$, be a hyperbola in the xy -plane whose conjugate axis LM subtends

an angle of 60° at one of its vertices N . Let the area of the triangle LMN be $4\sqrt{3}$.

LIST-I

- P. The length of the conjugate axis of H is
Q. The eccentricity of H is
R. The distance between the foci of H is
S. The length of the latus rectum of H is

LIST-II

1. 8
2. $\frac{4}{\sqrt{3}}$
3. $\frac{2}{\sqrt{3}}$
4. 4

The correct option is:

- (A) $P \rightarrow 4; Q \rightarrow 2; R \rightarrow 1; S \rightarrow 3$
(B) $P \rightarrow 4; Q \rightarrow 3; R \rightarrow 1; S \rightarrow 2$
(C) $P \rightarrow 4; Q \rightarrow 1; R \rightarrow 3; S \rightarrow 2$
(D) $P \rightarrow 3; Q \rightarrow 4; R \rightarrow 2; S \rightarrow 1$

Answer (B)

Sol.

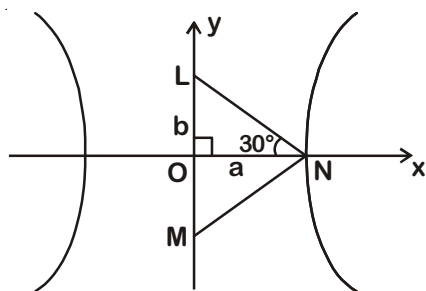

$$\tan 30^\circ = \frac{b}{a}$$

$$\Rightarrow b = \frac{a}{\sqrt{3}} \quad \dots(i)$$

$$\text{Now area of } \triangle OLN = \frac{1}{2}ab$$

$$\Rightarrow \frac{1}{2}ab = 2\sqrt{3}$$

$$\Rightarrow ab = 4\sqrt{3} \quad \dots(ii)$$

From (i) and (ii) we have $a = 2\sqrt{3}$, $b = 2$

$$\text{Now } e = \sqrt{1 + \frac{b^2}{a^2}} = \sqrt{1 + \frac{4}{12}} = \frac{2}{\sqrt{3}}$$

Distance between foci = $2ae$

$$= 2 \times 2\sqrt{3} \cdot \frac{2}{\sqrt{3}} = 8$$

$$\text{The length of latus rectum} = \frac{2b^2}{a} = \frac{2 \times 4}{2\sqrt{3}} = \frac{4}{\sqrt{3}}$$

18. Let $f_1 : \mathbb{R} \rightarrow \mathbb{R}$, $f_2 : \left(-\frac{\pi}{2}, \frac{\pi}{2}\right) \rightarrow \mathbb{R}$, $f_3 : \left(-1, e^{\frac{\pi}{2}} - 2\right) \rightarrow \mathbb{R}$ and $f_4 : \mathbb{R} \rightarrow \mathbb{R}$ be functions defined by

(i) $f_1(x) = \sin(\sqrt{1-e^{-x^2}})$,

(ii) $f_2(x) = \begin{cases} \frac{|\sin x|}{\tan^{-1} x} & \text{if } x \neq 0 \\ 1 & \text{if } x = 0 \end{cases}$, where the inverse trigonometric function $\tan^{-1} x$ assumes values

$$\text{in } \left(-\frac{\pi}{2}, \frac{\pi}{2}\right)$$

(iii) $f_3(x) = [\sin(\log_e(x+2))]$, where, for $t \in \mathbb{R}$, $[t]$ denotes the greatest integer less than or equal to t ,

(iv) $f_4(x) = \begin{cases} x^2 \sin\left(\frac{1}{x}\right) & \text{if } x \neq 0 \\ 0 & \text{if } x = 0 \end{cases}$

List-I

- P. The function f_1 is
 Q. The function f_2 is
 R. The function f_3 is
 S. The function f_4 is

List-II

1. NOT continuous at $x = 0$
2. continuous at $x = 0$ and NOT differentiable at $x = 0$
3. differentiable at $x = 0$ and its derivative is NOT continuous at $x = 0$
4. differentiable at $x = 0$ and its derivative is continuous at $x = 0$

The correct option is :

- (A) $P \rightarrow 2; Q \rightarrow 3; R \rightarrow 1; S \rightarrow 4$
 (B) $P \rightarrow 4; Q \rightarrow 1; R \rightarrow 2; S \rightarrow 3$
 (C) $P \rightarrow 4; Q \rightarrow 2; R \rightarrow 1; S \rightarrow 3$
 (D) $P \rightarrow 2; Q \rightarrow 1; R \rightarrow 4; S \rightarrow 3$

Answer (D)

Sol. (i) $f_1 : \mathbb{R} \rightarrow \mathbb{R}$

$$f_1(x) = \sin\left(\sqrt{1-e^{-x^2}}\right) = \sin\left(\sqrt{1-\frac{1}{e^{x^2}}}\right)$$

$f_1(x)$ is continuous everywhere, but $f_1'(0)$ does not exist, therefore $f_1(x)$ is not differentiable function at $x = 0$.

(ii) $f_2 : \left(-\frac{\pi}{2}, \frac{\pi}{2}\right) \rightarrow \mathbb{R}$

$$f_2(x) = \begin{cases} -\frac{\sin x}{\tan^{-1} x} & ; x < 0 \\ 1 & ; x = 0 \\ \frac{\sin x}{\tan^{-1} x} & ; x > 0 \end{cases}$$

LHL at $x = 0$ is -1

RHL at $x = 0$ is 1

$\therefore f_2(x)$ is discontinuous at $x = 0$,

(iii) $f_3 : \left[-1, e^2 - 2\right] \rightarrow \mathbb{R}$

$$f_3(x) = [\sin(\log_e(x+2))]$$

$$\therefore -1 < x < e^{\frac{\pi}{2}} - 2$$

$$1 < x + 2 < e^{\frac{\pi}{2}}$$

$$\Rightarrow 0 < \log_e(x+2) < \frac{\pi}{2}$$

$$\Rightarrow 0 < \sin(\log_e(x+2)) < 1$$

$$\Rightarrow [\sin(\log_e(x+2))] = 0$$

$$\Rightarrow f_3(x) = 0$$

$$\Rightarrow f_3(x) \text{ is continuous and differentiable at } x = 0$$

(iv) $f_4 : \mathbb{R} \rightarrow \mathbb{R}$

$$f_4(x) = \begin{cases} x^2 \sin\left(\frac{1}{x}\right) & ; x \neq 0 \\ 0 & ; x = 0 \end{cases}$$

$$\lim_{x \rightarrow 0} f_4(x) = \lim_{x \rightarrow 0} x^2 \sin\left(\frac{1}{x}\right) = 0$$

= Value of $f_4(x)$ at $x = 0$ $\Rightarrow f_4(x)$ is continuous at $x = 0$

$$\text{Now, } f'(0^+) = \lim_{h \rightarrow 0} \frac{f(0+h) - f(0)}{h} = \lim_{h \rightarrow 0} \frac{\sin\left(\frac{1}{h}\right)}{\frac{1}{h}} = 0$$

$$f'(0^-) = \lim_{h \rightarrow 0} \frac{f(0-h) - f(0)}{-h} = \lim_{h \rightarrow 0} \frac{\sin\left(\frac{1}{h}\right)}{\frac{1}{h}} = 0$$

 $\Rightarrow f(x)$ is differentiable at $x = 0$

$$\begin{aligned} \text{Now, } f_4'(x) &= 2x \sin\left(\frac{1}{x}\right) - x^2 \cdot \frac{1}{x^2} \cos\left(\frac{1}{x}\right) \\ &= 2x \sin\left(\frac{1}{x}\right) - \cos\left(\frac{1}{x}\right) \text{ is oscillating} \end{aligned}$$

Function which discontinuous at $x = 0$

END OF THE QUESTION PAPER

