

DATE : 21/05/2017



Aakash

Medical | IIT-JEE | Foundations

(Divisions of Aakash Educational Services Pvt. Ltd.)

Regd. Office : Aakash Tower, 8, Pusa Road, New Delhi-110005

Ph.: 011-47623456 Fax : 011-47623472

CODE

0

Time : 3 hrs.

Max. Marks: 183

Answers & Solutions

for

JEE (Advanced)-2017

PAPER - 1 (Code - 0)

INSTRUCTIONS

QUESTION PAPER FORMAT AND MARKING SCHEME :

1. The question paper has **three parts** : Physics, Chemistry and Mathematics.
2. Each part has three sections as detailed in the following table :

Section	Question Type	Number of Questions	Category-wise Marks for Each Question				Maximum Marks of the Section
			Full Marks	Partial Marks	Zero Marks	Negative Marks	
1	One or more correct option(s)	7	+4 If only the bubble(s) corresponding to all the correct option(s) is(are) darkened	+1 For darkening a bubble corresponding to each correct option, provided NO incorrect option is darkened	0 If none of the bubbles is darkened	-2 In all other cases	28
2	Single digit Integer (0-9)	5	+3 If only the bubble corresponding to the correct answer is darkened	—	0 In all other cases	—	15
3	Single Correct Option	6	+3 If only the bubble corresponding to the correct option is darkened	—	0 If none of the bubbles is darkened	-1 In all other cases	18

PHYSICS

SECTION - 1 (Maximum Marks : 28)

This section contains **SEVEN** questions.

Each question has **FOUR** options [A], [B], [C] and [D]. **ONE OR MORE THAN ONE** of these four option(s) is(are) correct.

For each question, darken the bubble(s) corresponding to all the correct option(s) in the ORS.

For each question, marks will be awarded in one of the following categories:

Full Marks : +4 If only the bubble(s) corresponding to the correct option(s) is(are) darkened.

Partial Marks : +1 For darkening a bubble corresponding to **each correct option**, provided NO incorrect option is darkened.

Zero Marks : 0 If none of the bubbles is darkened.

Negative Marks : -2 In all other cases.

For example, if [A], [C] and [D] are all the correct options for a question, darkening all these three will get +4 marks; darkening only [A] and [D] will get +2 marks; and darkening [A] and [B] will get -2 marks, as a wrong option is also darkened.

1. In the circuit shown, $L = 1 \mu\text{H}$, $C = 1 \mu\text{F}$ and $R = 1 \text{k}\Omega$. They are connected in series with an a.c. source $V = V_0 \sin \omega t$ as shown. Which of the following options is/are correct?

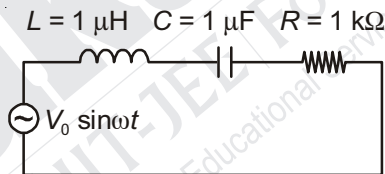

- (A) At $\omega \sim 0$ the current flowing through the circuit becomes nearly zero
 (B) The frequency at which the current will be in phase with the voltage is independent of R
 (C) The current will be in phase with the voltage if $\omega = 10^4 \text{ rad.s}^{-1}$
 (D) At $\omega \gg 10^6 \text{ rad. s}^{-1}$, the circuit behaves like a capacitor

Answer (A, B)

Sol. At $\omega \gg 10^6$

$$\begin{aligned} X_L &= \omega L \\ &= 10^6 \times 10^{-6} \text{ for } \omega = 10^6 \\ &= 1 \Omega \Rightarrow X_L \gg 1 \Omega \text{ for } \omega \gg 10^6 \end{aligned}$$

$$X_C = \frac{1}{\omega C} = \frac{1}{10^6 \times 10^{-6}} = 1 \Omega \text{ at } \omega = 10^6 \Rightarrow X_C \ll 1 \Omega \text{ for } \omega \gg 10^6$$

$$R = 1 \text{ k}\Omega$$

$$\omega_R = \frac{1}{\sqrt{LC}} = \frac{1}{\sqrt{10^{-6} \times 10^{-6}}} = 10^6 \text{ rad.s}^{-1}$$

At $\omega \rightarrow 0$ $X_C \rightarrow \infty \Rightarrow \text{current} \rightarrow 0$

2. For an isosceles prism of angle A and refractive index μ , it is found that the angle of minimum deviation $\delta_m = A$. Which of the following options is/are correct?
- (A) For the angle of incidence $i_1 = A$, the ray inside the prism is parallel to the base of the prism
- (B) At minimum deviation, the incident angle i_1 and the refracting angle r_1 at the first refracting surface are related by $r_1 = (i_1/2)$
- (C) For this prism, the emergent ray at the second surface will be tangential to the surface when the angle of incidence at the first surface is $i_1 = \sin^{-1} \left[\sin A \sqrt{4 \cos^2 \frac{A}{2} - 1} - \cos A \right]$
- (D) For this prism, the refractive index μ and the angle of prism A are related as $A = \frac{1}{2} \cos^{-1} \left(\frac{\mu}{2} \right)$

Answer (A, B, C)

Sol. $\delta_m = (2i) - A$

$\Rightarrow 2A = 2i$

$\Rightarrow i = A$ and $r = A/2$ (look solution at right side)

$$\mu = \frac{\sin \left[\frac{A+A}{2} \right]}{\sin \left[\frac{A}{2} \right]}$$

$$= \frac{2 \sin \frac{A}{2} \cos \frac{A}{2}}{\sin \frac{A}{2}}$$

$$\mu = 2 \cos \frac{A}{2}$$

$$1 \sin i_1 = \mu \times \sin(A - \theta_c)$$

$$= 2 \cos \frac{A}{2} \left[\sin A \cos \theta_c - \cos A \sin \theta_c \right]$$

$$= 2 \cos \frac{A}{2} \left[\sin A \sqrt{1 - \sin^2 \theta_c} - \cos A \frac{1}{\mu} \right]$$

$$= 2 \cos \frac{A}{2} \left[\sin A \sqrt{1 - \frac{1}{\mu^2}} - \frac{\cos A}{\left(2 \cos \frac{A}{2} \right)} \right]$$

$$= 2 \cos \frac{A}{2} \left[\sin A \sqrt{1 - \frac{1}{4 \cos^2 \frac{A}{2}}} - \frac{\cos A}{2 \cos \frac{A}{2}} \right]$$

$$i_1 = \sin^{-1} \left[\sin A \left[\sqrt{4 \cos^2 \frac{A}{2} - 1} - \cos A \right] \right]$$

$r_1 = \frac{A}{2}$ for minimum deviation.

$$\frac{A}{2} = \cos^{-1} \left[\frac{\mu}{2} \right] \Rightarrow A = 2 \cos^{-1} \left[\frac{\mu}{2} \right]$$

Calculation of r for $i = A$

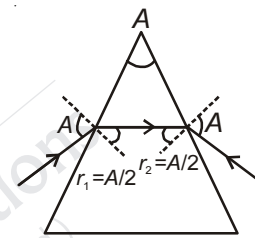

$$1 \sin A = \mu \sin r$$

$$\sin A = 2 \cos \frac{A}{2} \cdot \sin r$$

$$\sin r = \frac{2 \sin \frac{A}{2} \cos \frac{A}{2}}{2 \cos \frac{A}{2}} = \sin \frac{A}{2}$$

$$\Rightarrow r = \frac{A}{2}$$

3. A circular insulated copper wire loop is twisted to form two loops of area A and $2A$ as shown in the figure. At the point of crossing the wires remain electrically insulated from each other. The entire loop lies in the plane (of the paper). A uniform magnetic field \vec{B} points into the plane of the paper. At $t = 0$, the loop starts rotating about the common diameter as axis with a constant angular velocity ω in the magnetic field. Which of the following options is/are correct?

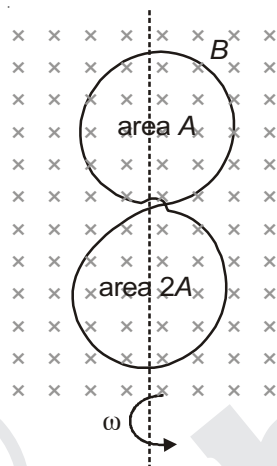

- (A) The emf induced in the loop is proportional to the sum of the areas of the two loops
 (B) The rate of change of the flux is maximum when the plane of the loops is perpendicular to plane of the paper
 (C) The net emf induced due to both the loops is proportional to $\cos \omega t$
 (D) The amplitude of the maximum net emf induced due to both the loops is equal to the amplitude of maximum emf induced in the smaller loop alone

Answer (B, D)

Sol. $\phi = BA \cos \omega t$

$$|e| = B\omega \sin \omega t$$

For loop 1

$$\phi_1 = BA \cos \omega t : |e_1| = AB\omega \sin \omega t$$

$$\phi_2 = 2BA \sin \omega t \quad |e_2| = 2BA\omega \sin \omega t$$

e_1 and e_2 oppose each other, so amplitude of net emf induced = $2BA\omega - BA\omega = BA\omega$

e_1 and e_2 will be peak at $\omega t = \pi/2$ or $\theta = 90^\circ$.

4. A flat plate is moving normal to its plane through a gas under the action of a constant force F . The gas is kept at a very low pressure. The speed of the plate v is much less than the average speed u of the gas molecules. Which of the following options is/are true?

- (A) At a later time the external force F balances the resistive force
 (B) The plate will continue to move with constant non-zero acceleration, at all times
 (C) The resistive force experienced by the plate is proportional to v
 (D) The pressure difference between the leading and trailing faces of the plate is proportional to uv

Answer (A, C, D)

Sol. n = number of molecules per unit volume

u = average speed of gas molecules

When plate is moving with speed v , relative speed of molecules w.r.t. leading face = $v + u$

Coming head on, momentum transferred to plate per collision = $2m(u + v)$

$$\text{Number of collision in time } \Delta t = \frac{1}{2}(v + v_0)n\Delta tA$$

where A = Surface area

So, momentum transferred in time $\Delta t = m(u + v)^2 n A \Delta t$ from front surface

Similarly momentum transferred in time $= m(u - v)^2 n A \Delta t$ from back surface.

Net force $= mnA[(v + u)^2 - (u - v)^2]$

$$= mnA[4uv]$$

$$F \propto v$$

$$P_{\text{leading}} - P_{\text{trailing}} = mn[u + v]^2 - mn[u - v]^2$$

$$= mn[4uv] = 4mnv$$

$$\Delta P \propto uv$$

5. A block of mass M has a circular cut with a frictionless surface as shown. The block rests on the horizontal frictionless surface of a fixed table. Initially the right edge of the block is at $x = 0$, in a co-ordinate system fixed to the table. A point mass m is released from rest at the topmost point of the path as shown and it slides down. When the mass loses contact with the block, its position is x and the velocity is v . At that instant, which of the following options is/are correct?

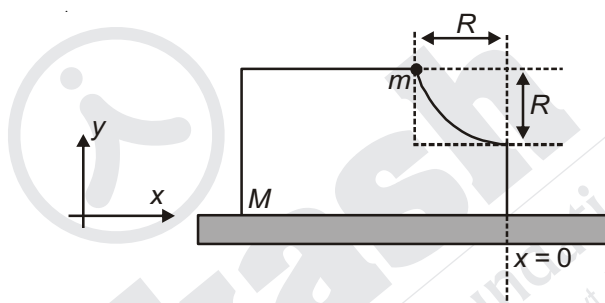

(A) The velocity of the point mass m is: $v = \sqrt{\frac{2gR}{1 + \frac{m}{M}}}$

(B) The x component of displacement of the center of mass of the block M is: $-\frac{mR}{M + m}$

(C) The position of the point mass is: $x = -\sqrt{2} \frac{mR}{M + m}$

(D) The velocity of the block M is: $V = -\frac{m}{M} \sqrt{2gR}$

Answer (A, B)

Sol. v = velocity of M

u = velocity of m

$$mu = -MV \quad \dots(i)$$

$$mgR = \frac{1}{2} mu^2 + \frac{1}{2} MV^2 \quad \dots(ii)$$

$$\therefore \boxed{u = \sqrt{\frac{2gR}{1 + \frac{m}{M}}} \quad v = \frac{-m}{M} \sqrt{\frac{2gR}{1 + \frac{m}{M}}}}$$

and $Mx' = m(R - x')$ where x' = displacement of block M

$$x'(M + m) = mR \quad \Rightarrow \quad x' = \frac{mR}{m + M} \quad \text{towards left}$$

Or $\boxed{x' = -\frac{mR}{m + M}}$

6. A block M hangs vertically at the bottom end of a uniform rope of constant mass per unit length. The top end of the rope is attached to a fixed rigid support at O . A transverse wave pulse (Pulse 1) of wavelength λ_0 is produced at point O on the rope. The pulse takes time T_{OA} to reach point A . If the wave pulse of wavelength λ_0 is produced at point A (Pulse 2) without disturbing the position of M it takes time T_{AO} to reach point O . Which of the following options is/are correct?

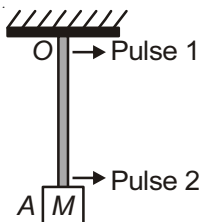

- (A) The time $T_{AO} = T_{OA}$
 (B) The wavelength of Pulse 1 becomes longer when it reaches point A
 (C) The velocity of any pulse along the rope is independent of its frequency and wavelength
 (D) The velocities of the two pulses (Pulse 1 and Pulse 2) are the same at the midpoint of rope

Answer (A, C, D)

Sol. At any point $v = \sqrt{\frac{T}{\mu}}$, since velocity depends on tension at a point and mass per unit length, so time from O to A and A to O will be same.

$$T_{OA} = T_{AO}$$

Also frequency remain constant at all point. To keep it same, $\frac{v}{\lambda}$ must be same and v is maximum at O ($T \rightarrow$ maximum) so λ must be longest at O .

7. A human body has a surface area of approximately 1 m^2 . The normal body temperature is 10 K above the surrounding room temperature T_0 . Take the room temperature to be $T_0 = 300 \text{ K}$. For $T_0 = 300 \text{ K}$, the value of $\sigma T_0^4 = 460 \text{ Wm}^{-2}$ (where σ is the Stefan-Boltzmann constant). Which of the following options is/are correct?
- (A) If the body temperature rises significantly then the peak in the spectrum of electromagnetic radiation emitted by the body would shift to longer wavelengths
 (B) If the surrounding temperature reduces by a small amount $\Delta T_0 \ll T_0$, then to maintain the same body temperature the same (living) human being needs to radiate $\Delta W = 4\sigma T_0^3 \Delta T_0$ more energy per unit time
 (C) The amount of energy radiated by the body in 1 second is close to 60 Joules
 (D) Reducing the exposed surface area of the body (e.g. by curling up) allows humans to maintain the same body temperature while reducing the energy lost by radiation

Answer (B, C, D)

Sol. Body metabolic system will have to produce additional energy in order to maintain the temperature.

Let due to internal metabolism, power produced is I ,

As temperature of body is constant, $\Delta Q_{\text{net}} = 0$

$$\Rightarrow I = \sigma A [T^4 - T_0^4]$$

$$\Rightarrow dI = 4\sigma A T_0^3 (dT_0) = 4\sigma A T_0^3 \cdot \Delta T_0 \quad (\text{option B})$$

$$= 4 \times 460 \times \frac{10}{300} \approx 60 \text{ J/s} \quad (\text{option C})$$

SECTION - 2 (Maximum Marks : 15)

This section contains **FIVE** questions.

The answer to each question is a **SINGLE DIGIT INTEGER** ranging from 0 to 9, both inclusive.

For each question, darken the bubble corresponding to the correct integer in the ORS.

For each question, marks will be awarded in one of the following categories:

Full Marks : +3 If only the bubble corresponding to the correct answer is darkened.

Zero Marks : 0 In all other cases.

8. An electron in a hydrogen atom undergoes a transition from an orbit with quantum number n_i to another with quantum number n_f . V_i and V_f are respectively the initial and final potential energies of the electron. If $\frac{V_i}{V_f} = 6.25$, then the smallest possible n_f is

Answer (5)

Sol. $PE = -27.2 \frac{Z^2}{n^2}$ $Z = 1$ for H

$$PE = \frac{-27.2}{n^2}$$

$$V_i = PE_1 = \frac{-27.2}{n_i^2} \quad \therefore PE_2 = \frac{-27.2}{n_f^2} = V_f$$

$$\frac{V_i}{V_f} = \frac{n_f^2}{n_i^2} = \left(\frac{n_f}{n_i}\right)^2 = 6.25$$

$$n_f = 2.5 n_i$$

$$\frac{n_f}{n_i} = \frac{5}{2}$$

$$\Rightarrow n_i \text{ min} = 2$$

$$n_f \text{ min} = 5$$

$$n_f = 5$$

9. A drop of liquid of radius $R = 10^{-2}$ m having surface tension $S = \frac{0.1}{4\pi} \text{ Nm}^{-1}$ divides itself into K identical drops. In this process the total change in the surface energy $\Delta U = 10^{-3}$ J. If $K = 10^\alpha$ then the value of α is

Answer (6)

Sol. Let radius of small drops = r .

$$\frac{4}{3}\pi R^3 = K \frac{4}{3}\pi r^3$$

$$R = K^{\frac{1}{3}} r \quad \dots(i)$$

$$S(K4\pi r^2 - 4\pi R^2) = 10^{-3}$$

$$\frac{0.1}{4\pi} 4\pi \left(k \frac{R^2}{K^{\frac{2}{3}}} - R^2 \right) = 10^{-3}$$

$$R^2 \left(K^{\frac{1}{3}} - 1 \right) = 10^{-2}$$

$$K^{\frac{1}{3}} - 1 = 100$$

$$K^{\frac{1}{3}} = 101$$

$$10^{\frac{\alpha}{3}} = 101$$

$$\alpha \approx 6$$

10. A stationary source emits sound of frequency $f_0 = 492$ Hz. The sound is *reflected* by a large car *approaching* the source with a speed of 2 ms^{-1} . The reflected signal is received by the source and superposed with the original. What will be the beat frequency of the resulting signal in Hz? (Given that the speed of sound in air is 330 ms^{-1} and the car reflects the sound at the frequency *it* has received).

Answer (6)

Sol. Frequency of sound emitted by stationary source, $f_0 = 492$ Hz

Frequency of sound reflected by moving car

$$f' = f_0 \left[\frac{c + v_c}{c - v_c} \right]$$

where $c =$ speed of sound in air = 330 m/s

$v_c =$ speed of car = 2 m/s

On solving

$$f' = 492 \times \frac{332}{328} \approx 498 \text{ Hz}$$

Beat frequency of resulting signal = $f' - f_0$

$$= (498 - 492) \text{ Hz}$$

$$= 6 \text{ Hz}$$

11. ^{131}I is an isotope of Iodine that β decays to an isotope of Xenon with a half-life of 8 days. A small amount of a serum labelled with ^{131}I is injected into the blood of a person. The activity of the amount of ^{131}I injected was 2.4×10^5 Becquerel (Bq). It is known that the injected serum will get distributed uniformly in the blood stream in less than half an hour. After 11.5 hours, 2.5 ml of blood is drawn from person's body, and gives an activity of 115 Bq. The total volume of blood in the person's body, in liters is approximately (you may use $e^x \approx 1 + x$ for $|x| \ll 1$ and $\ln 2 \approx 0.7$).

Answer (5)

Sol. Suppose total volume of blood is V ml

$$\therefore 2.5 \text{ ml of blood activity} = 115 \text{ Bq}$$

$$\therefore 1 \text{ ml of blood activity} = \frac{115}{2.5}$$

$$\therefore \text{Activity of whole blood} = \left(\frac{115}{2.5}\right) V \text{ Bq}$$

$$\left(\frac{115V}{2.5}\right) = 2.4 \times 10^5 e^{-\lambda t}$$

$$= 2.4 \times 10^5 e^{-\frac{\ln 2}{8 \times 24} \times 11.5}$$

$$= 2.4 \times 10^5 e^{-\frac{0.7 \times 11.5}{8 \times 24}}$$

$$= 2.4 \times 10^5 e^{-\frac{1}{24}}$$

$$= 2.4 \times 10^5 \left(1 - \frac{1}{24}\right)$$

$$V = 2.4 \times 10^5 \times \frac{23}{24} \times \frac{2.5}{115} \approx 5000 \text{ ml}$$

\therefore Total volume of blood = 5 L

12. A monochromatic light is travelling in a medium of refractive index $n = 1.6$. It enters a stack of glass layers from the bottom side at an angle $\theta = 30^\circ$. The interfaces of the glass layers are parallel to each other. The refractive indices of different glass layers are monotonically decreasing as $n_m = n - m\Delta n$, where n_m is the refractive index of the m^{th} slab and $\Delta n = 0.1$ (see the figure). The ray is refracted out parallel to the interface between the $(m - 1)^{\text{th}}$ and m^{th} slabs from the right side of the stack. What is the value of m ?

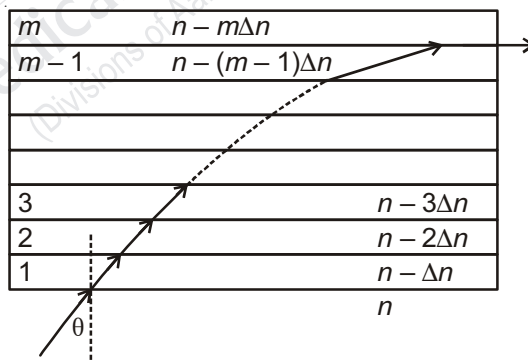

Answer (8)

Sol. Considering Snell's law between first layer and m^{th} layer.

$$n \sin \theta = (n - m\Delta n) \sin 90^\circ$$

$$1.6 \times \frac{1}{2} = (1.6 - m(0.1)) \cdot 1$$

$$m = \frac{0.8}{0.1} = 8$$

CHEMISTRY

SECTION - 1 (Maximum Marks : 28)

This section contains **SEVEN** questions.

Each question has **FOUR** options (A), (B), (C) and (D). **ONE OR MORE THAN ONE** of these four options is(are) correct.

For each question, darken the bubble(s) corresponding to all the correct option(s) in the ORS.

For each question, marks will be awarded in one of the following categories:

Full Marks : +4 If only the bubble(s) corresponding to all the correct option(s) is(are) darkened.

Partial Marks : +1 For darkening a bubble corresponding to **each correct option**, provided NO incorrect option is darkened

Zero Marks : 0 If none of the bubbles is darkened

Negative Marks : -2 In all other cases

For example, if (A), (C) and (D) are all the correct options for a question, darkening all these three will get +4 marks; darkening only (A) and (D) will get +2 marks; and darkening (A) and (B) will get -2 marks, as a wrong option is also darkened.

19. The colour of the X_2 molecules of group 17 elements changes gradually from yellow to violet down the group. This is due to
- The physical state of X_2 at room temperature changes from gas to solid down the group
 - Decrease in HOMO-LUMO gap down the group
 - Decrease in $\pi^*-\sigma^*$ gap down the group
 - Decrease in ionization energy down the group

Answer (B, C)

Sol. The colours arise from the absorption of light on promoting an electron from the ground state to higher state. On descending the group, the energy levels become closer and gap between HOMO – LUMO decreases.

HOMO is π^*

LUMO is σ^*

20. Addition of excess aqueous ammonia to a pink coloured aqueous solution of $MCl_2 \cdot 6H_2O(X)$ and NH_4Cl gives an octahedral complex **Y** in the presence of air. In aqueous solution, complex **Y** behaves as 1:3 electrolyte. The reaction of **X** with excess HCl at room temperature results in the formation of a blue coloured complex **Z**. The calculated spin only magnetic moment of **X** and **Z** is 3.87 B.M., whereas it is zero for complex **Y**. Among the following options, which statement(s) is(are) correct?
- The hybridization of the central metal ion in **Y** is d^2sp^3
 - When **X** and **Z** are in equilibrium at $0^\circ C$, the colour of the solution is pink
 - Z** is a tetrahedral complex
 - Addition of silver nitrate to **Y** gives only two equivalents of silver chloride

Answer (A, B, C)

Sol. **(X)** = $CoCl_2 \cdot 6H_2O$, or, $[Co(H_2O)_6]Cl_2$ (Pink)

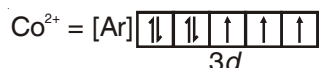

H_2O is weak field ligand, therefore No pairing of electron

∴ Number of unpaired electron, $n = 3$

$$\begin{aligned} \Rightarrow \mu_s &= \sqrt{n(n+2)} \text{ B.M.} \\ &= \sqrt{15} \text{ B.M.} \\ &= 3.87 \text{ B.M.} \end{aligned}$$

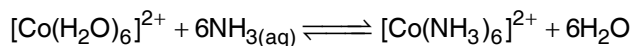

O_2 will oxidise $[\text{Co}(\text{NH}_3)_6]^{2+}$ to $[\text{Co}(\text{NH}_3)_6]^{3+}$, therefore shift in forward

∴ $\text{Y} = [\text{Co}(\text{NH}_3)_6]^{3+}\text{Cl}_3$ [1 : 3 complex]

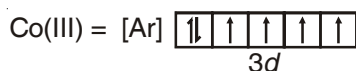

NH_3 is strong field ligand

∴ Forces electrons to pair up

∴ $n = 0$

$\mu = 0$ B.M.

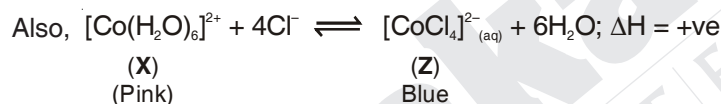
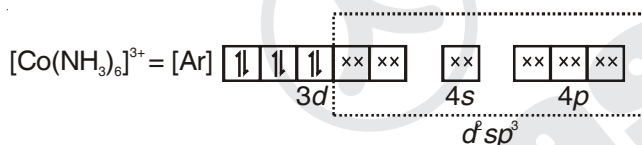

At 0°C , equilibrium shifts in backward, therefore Pink colour.

21. An ideal gas is expanded from (p_1, V_1, T_1) to (p_2, V_2, T_2) under different conditions. The correct statement(s) among the following is(are)
- (A) If the expansion is carried out freely, it is simultaneously both isothermal as well as adiabatic
- (B) The work done by the gas is less when it is expanded reversibly from V_1 to V_2 under adiabatic conditions as compared to that when expanded reversibly from V_1 to V_2 under isothermal conditions
- (C) The work done on the gas is maximum when it is compressed irreversibly from (p_2, V_2) to (p_1, V_1) against constant pressure p_1
- (D) The change in internal energy of the gas is (i) zero, if it is expanded reversibly with $T_1 = T_2$, and (ii) positive, if it is expanded reversibly under adiabatic conditions with $T_1 \neq T_2$

Answer (A, B, C)

Sol. (A) In free expansion, $P_{\text{ex}} = 0 \Rightarrow w = 0$
For isothermal free expansion of an ideal gas,
 $\Delta U = 0 \Rightarrow q = 0 \therefore$ adiabatic also

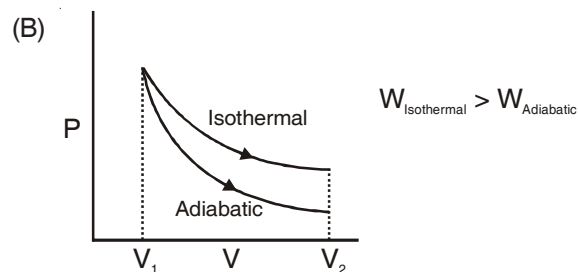

Answer (A, B)

Sol. IUPAC name

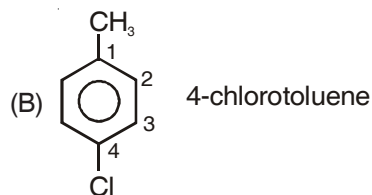
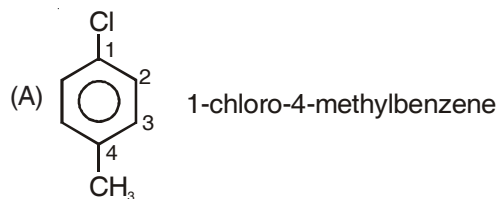

24. The correct statement(s) for the following addition reactions is(are)

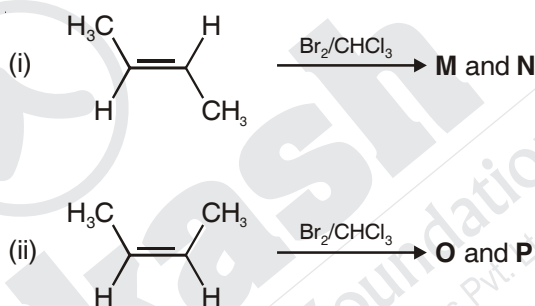

- (A) **O** and **P** are identical molecules
 (B) Bromination proceeds through *trans*-addition in both the reactions
 (C) (**M** and **O**) and (**N** and **P**) are two pairs of enantiomers
 (D) (**M** and **O**) and (**N** and **P**) are two pairs of diastereomers

Answer (B, D)

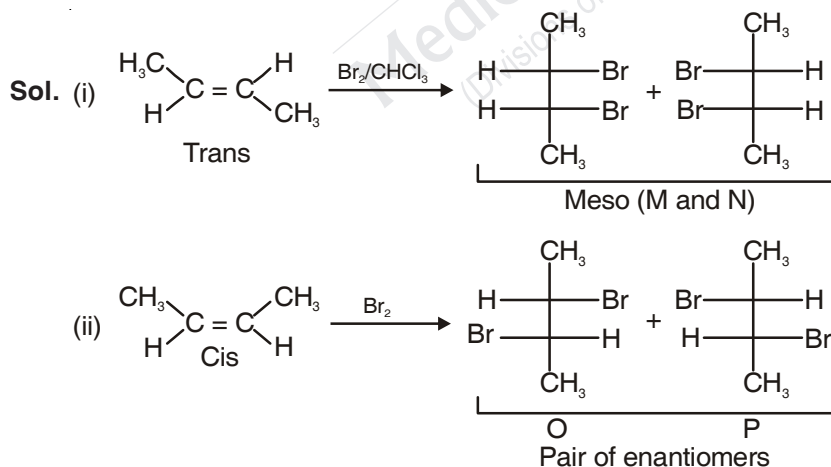

Cis anti Racemic

M and N are meso (identical)

O and P are pair of enantiomers

- (B) Bromination proceeds through anti addition.
 (D) (M and O) and (N and P) are two pairs of diastereomer.

25. The correct statement(s) about the oxoacids, HClO_4 and HClO , is(are)
- (A) The conjugate base of HClO_4 is weaker base than H_2O
- (B) The central atom in both HClO_4 and HClO is sp^3 hybridized
- (C) HClO_4 is formed in the reaction between Cl_2 and H_2O
- (D) HClO_4 is more acidic than HClO because of the resonance stabilization of its anion

Answer (A, B, D)

Sol. (A) $\text{HClO}_4 > \text{H}_2\text{O}$ Acidic character

$\text{ClO}_4^- < \text{OH}^-$ Conjugate Base

Strong acids have weak conjugate base

(B) Both HClO_4 and HClO central atom is sp^3 hybridised

(D) $\text{HClO}_4 > \text{HClO}$ Acidic strength

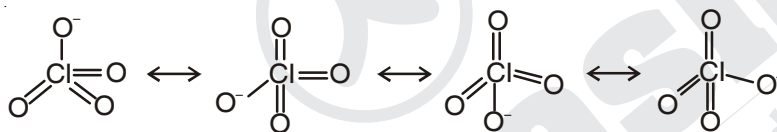
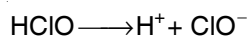
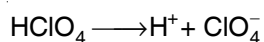

In ClO_4^- , negative charge is dispersed on four oxygen, so better resonance stabilised.

SECTION - 2 (Maximum Marks : 15)

This section contains **FIVE** questions.

The answer to each question is a **SINGLE DIGIT INTEGER** ranging from 0 to 9, both inclusive.

For each question, darken the bubble corresponding to the correct integer in the ORS.

For each question, marks will be awarded in one of the following categories:

Full Marks : +3 If only the bubble corresponding to the correct answer is darkened.

Zero Marks : 0 In all other cases.

26. The conductance of a 0.0015 M aqueous solution of a weak monobasic acid was determined by using a conductivity cell consisting of platinized Pt electrodes. The distance between the electrodes is 120 cm with an area of cross section of 1 cm^2 . The conductance of this solution was found to be $5 \times 10^{-7} \text{ S}$. The pH of the solution is 4. The value of limiting molar conductivity (Λ_m^0) of this weak monobasic acid in aqueous solution is $Z \times 10^2 \text{ S cm}^{-1} \text{ mol}^{-1}$. The value of Z is

Answer (6)

Sol. $\kappa = C \left(\frac{l}{A} \right)$

$$= 5 \times 10^{-7} \times \frac{120}{1}$$

$$= 6 \times 10^{-5} \text{ S cm}^{-1}$$

$$\lambda_M = \frac{\kappa \times 1000}{M}$$

$$= \frac{6 \times 10^{-5} \times 1000}{15 \times 10^{-4}}$$

$$\Rightarrow \lambda_M = 40 \text{ S cm}^2 \text{ mol}^{-1}$$

$$[H^+] = C\alpha = 10^{-4}$$

$$\alpha = \frac{10^{-4}}{15 \times 10^{-4}} = \frac{1}{15}$$

$$\Rightarrow \alpha = \frac{\lambda_M}{\lambda_M^\circ}$$

$$\begin{aligned} \Rightarrow \lambda_M^\circ &= 40 \times 15 \\ &= 600 = 6 \times 10^2 \text{ S cm}^{-1} \text{ mol}^{-1} \end{aligned}$$

27. The sum of the number of lone pairs of electrons on each central atom in the following species is

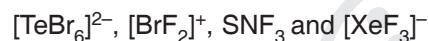

(Atomic numbers: N = 7, F = 9, S = 16, Br = 35, Te = 52, Xe = 54)

Answer (6)

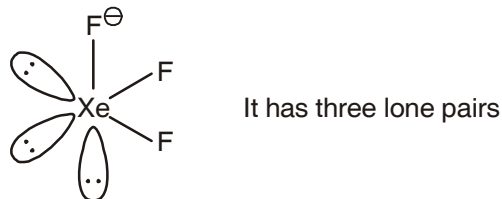
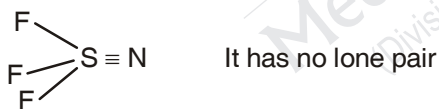
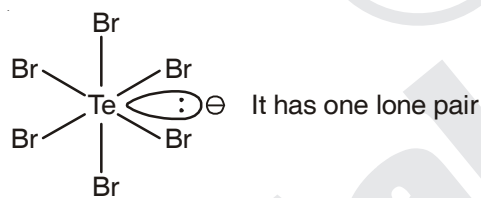

Sol.



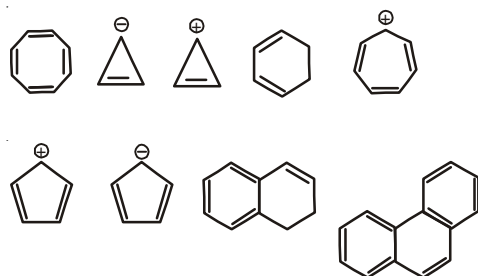



28. Among the following, the number of aromatic compound(s) is

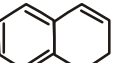
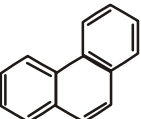

Answer (5)

Sol. , , ,  and  are aromatic.

 and  are non-aromatic while  and  are antiaromatic compounds.

29. A crystalline solid of a pure substance has a face-centred cubic structure with a cell edge of 400 pm. If the density of the substance in the crystal is 8 g cm^{-3} , then the number of atoms present in 256 g of the crystal is $N \times 10^{24}$. The value of N is

Answer (2)

Sol. $a = 4 \times 10^{-8} \text{ cm}$ (a = edge length)

$d = 8 \text{ g cm}^{-3}$ (density)

$$d = \frac{ZM}{N_A a^3} \quad M = \text{molecular mass (g/mol)}$$

$Z \rightarrow$ number of atom in 1 unit cell

$$M = \frac{dN_A a^3}{Z} = \frac{8 \times 6 \times 10^{23} \times 64 \times 10^{-24}}{4} = 76.8 \text{ g/mol}$$

Mole of solid in 256 g = 3.33 moles

No. of atom = $3.33 \times N_A = 20 \times 10^{23} = 2 \times 10^{24}$

30. Among H_2 , He_2^+ , Li_2 , Be_2 , B_2 , C_2 , N_2 , O_2^- , and F_2 , the number of diamagnetic species is
(Atomic numbers: H = 1, He = 2, Li = 3, Be = 4, B = 5, C = 6, N = 7, O = 8, F = 9)

Answer (6)

Sol. $\text{H}_2 \sigma_{1s}^2$	Diamagnetic
$\text{He}_2^+ \sigma_{1s}^2 \sigma_{1s}^{*1}$	Paramagnetic
$\text{Li}_2 \sigma_{1s}^2 \sigma_{1s}^{*2} \sigma_{2s}^2$	Diamagnetic
$\text{Be}_2 \sigma_{1s}^2 \sigma_{1s}^{*2} \sigma_{2s}^2 \sigma_{2s}^{*2}$	Diamagnetic
$\text{B}_2 \sigma_{1s}^2 \sigma_{1s}^{*2} \sigma_{2s}^2 \sigma_{2s}^{*2} \pi_{2p_x}^1 = \pi_{2p_y}^1$	Paramagnetic
$\text{C}_2 \sigma_{1s}^2 \sigma_{1s}^{*2} \sigma_{2s}^2 \sigma_{2s}^{*2} \pi_{2p_x}^2 = \pi_{2p_y}^2$	Diamagnetic
$\text{N}_2 \sigma_{1s}^2 \sigma_{1s}^{*2} \sigma_{2s}^2 \sigma_{2s}^{*2} \pi_{2p_x}^2 = \pi_{2p_y}^2, \sigma_{2p_z}^2$	Diamagnetic
$\text{O}_2 \sigma_{1s}^2 \sigma_{1s}^{*2} \sigma_{2s}^2 \sigma_{2s}^{*2} \sigma_{2p_z}^2 \pi_{2p_x}^2 = \pi_{2p_y}^2, \pi_{2p_x}^{*1} = \pi_{2p_y}^{*1}$	Paramagnetic
$\text{F}_2 \sigma_{1s}^2 \sigma_{1s}^{*2} \sigma_{2s}^2 \sigma_{2s}^{*2} \sigma_{2p_z}^2 \pi_{2p_x}^2 = \pi_{2p_y}^2, \pi_{2p_x}^{*2} = \pi_{2p_y}^{*2}$	Diamagnetic

SECTION - 3 (Maximum Marks : 18)

This section contains **SIX** questions of matching type.

This section contains **TWO** tables (each having 3 columns and 4 rows).

Based on each table, there are **THREE** questions.

Each question has **FOUR** options (A), (B), (C) and (D). **ONLY ONE** of these four options is correct.

For each question, darken the bubble corresponding to the correct option in the ORS.

For each question, marks will be awarded in one of the following categories:

Full Marks : +3 If only the bubble corresponding to the correct option is darkened

Zero Marks : 0 If none of the bubbles is darkened

Negative Marks : -1 In all other cases

Answer Q.31, Q.32 and Q.33 by appropriately matching the information given in the three columns of the following table.

The wave function, ψ_{n,l,m_l} is a mathematical function whose value depends upon spherical polar coordinates (r, θ, ϕ) of the electron and characterized by the quantum numbers n, l and m_l . Here r is distance from nucleus, θ is colatitude and ϕ is azimuth. In the mathematical functions given in the table, Z is atomic number and a_0 is Bohr radius.

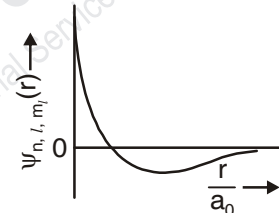
Column 1	Column 2	Column 3
(I) 1s orbital	(i) $\psi_{n,l,m_l} \propto \left(\frac{Z}{a_0}\right)^{\frac{3}{2}} e^{-\left(\frac{Zr}{a_0}\right)}$	(P) 
(II) 2s orbital	(ii) One radial node	(Q) Probability density at nucleus $\propto \frac{1}{a_0^3}$
(III) 2p _z orbital	(iii) $\psi_{n,l,m_l} \propto \left(\frac{Z}{a_0}\right)^{\frac{5}{2}} r e^{-\left(\frac{Zr}{2a_0}\right)} \cos\theta$	(R) Probability density is maximum at nucleus
(IV) 3d _{z²} orbital	(iv) xy-plane is a nodal plane	(S) Energy needed to excite electron from $n = 2$ state to $n = 4$ state is $\frac{27}{32}$ times the energy needed to excite electron from $n = 2$ state to $n = 6$ state

31. For He⁺ ion, the only **INCORRECT** combination is

(A) (I) (i) (R)

(B) (II) (ii) (Q)

(C) (I) (i) (S)

(D) (I) (iii) (R)

Answer (D)

Sol. 1s orbital is nondirectional so ψ will not depend upon $\cos\theta$.

hence 'D' is incorrect.

Answer (D)

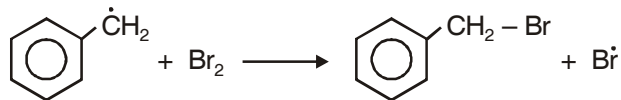
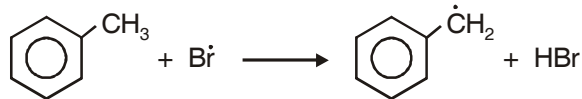
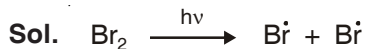

35. For the synthesis of benzoic acid, the only CORRECT combination is

(A) (III) (iv) (R)

(B) (IV) (ii) (P)

(C) (II) (i) (S)

(D) (I) (iv) (Q)

Answer (C)

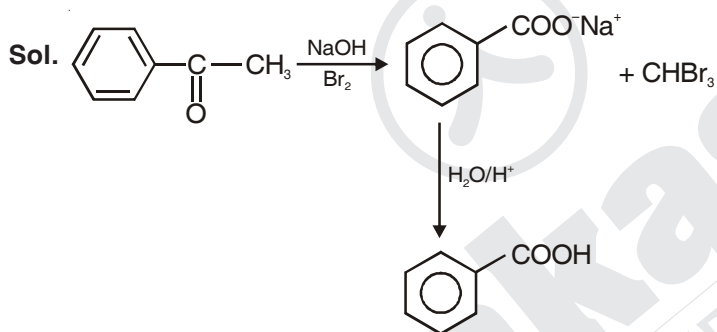

It is haloform reaction

36. The only CORRECT combination that gives two different carboxylic acids is

(A) (IV) (iii) (Q)

(B) (I) (i) (S)

(C) (III) (iii) (P)

(D) (II) (iv) (R)

Answer (C)

Sol.

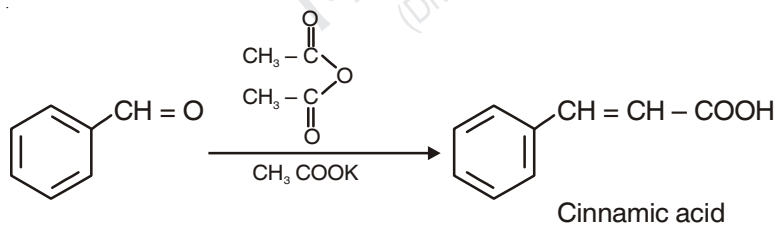

It exists in two geometrical forms.

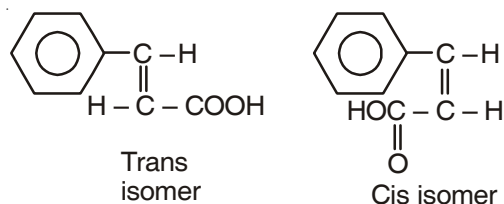

It is basic example of Perkin's reaction.

END OF CHEMISTRY

MATHEMATICS

SECTION - 1 (Maximum Marks : 28)

This section contains **SEVEN** questions.

Each question has **FOUR** options (A), (B), (C) and (D). **ONE OR MORE THAN ONE** of these four options is(are) correct.

For each question, darken the bubble(s) corresponding to all the correct option(s) in the ORS.

For each question, marks will be awarded in one of the following categories:

Full Marks : +4 If only the bubble(s) corresponding to all the correct option(s) is(are) darkened.

Partial Marks : +1 For darkening a bubble corresponding to **each correct option**, provided NO incorrect option is darkened

Zero Marks : 0 If none of the bubbles is darkened

Negative Marks : -2 In all other cases

For example, if (A), (C) and (D) are all the correct options for a question, darkening all these three will get +4 marks; darkening only (A) and (D) will get +2 marks; and darkening (A) and (B) will get -2 marks, as a wrong option is also darkened.

37. Let a, b, x and y be real numbers such that $a - b = 1$ and $y \neq 0$. If the complex number $z = x + iy$ satisfies

$$\operatorname{Im}\left(\frac{az+b}{z+1}\right) = y, \text{ then which of the following is(are) possible value(s) of } x ?$$

(A) $-1 + \sqrt{1 - y^2}$

(B) $1 - \sqrt{1 + y^2}$

(C) $1 + \sqrt{1 + y^2}$

(D) $-1 - \sqrt{1 - y^2}$

Answer (A, D)

Sol. $a - b \neq 1, y \neq 0, z = x + iy$

$$\operatorname{Im}\left(\frac{az+b}{z+1}\right) = y$$

$$\operatorname{Im}\left(\left(\frac{(ax+b) + ayi}{(x+1) + iy}\right) \times \left(\frac{x+1-iy}{x+1-iy}\right)\right) = y$$

$$\operatorname{Im}\left(\frac{(ax+b)(x+1) + ay^2 + ay(x+1)i - iy(ax+b)}{(x+1)^2 + y^2}\right) = y$$

$$\Rightarrow ay(x+1) - y(ax+b) = y(x+1)^2 + y^3$$

$$\Rightarrow ax + a - ax - b = x^2 + 2x + 1 + y^2$$

$$\Rightarrow a - b = x^2 + y^2 + 2x + 1$$

$$\Rightarrow 1 = x^2 + y^2 + 2x + 1$$

$$\Rightarrow (x+1)^2 = 1 - y^2$$

$$\Rightarrow x+1 = \pm\sqrt{1-y^2}$$

$$\Rightarrow x = -1 \pm \sqrt{1-y^2}$$

38. Let $f : \mathbb{R} \rightarrow (0, 1)$ be a continuous function. Then, which of the following function(s) has(have) the value zero at some point in the interval $(0, 1)$?

(A) $f(x) + \int_0^{\frac{\pi}{2}} f(t) \sin t \, dt$

(B) $x^9 - f(x)$

(C) $x - \int_0^{\frac{\pi}{2}-x} f(t) \cos t \, dt$

(D) $e^x - \int_0^x f(t) \sin t \, dt$

Answer (B, C)

Sol. $g(x) = x - \int_0^{\frac{\pi}{2}-x} f(t) \cos t \, dt$

$g(0) = 0 - \int_0^{\frac{\pi}{2}} f(t) \cos t \, dt < 0$ as $0 < f(t) \cos t < 1$

$g(1) = 1 - \int_0^{\frac{\pi}{2}-1} f(t) \cos t \, dt > 0$

$g(x) = x^9 - f(x) \rightarrow g(0) = 0 - f(0) < 0$

$g(1) = 1 - f(1) > 0$

Also for $(0, 1)$

$e^x - \int_0^x f(t) \sin t \, dt > 0$

Also, $f(x) + \int_0^{\frac{\pi}{2}} f(t) \sin t \, dt > 0 \quad \forall x \in (0, 1)$

39. If $2x - y + 1 = 0$ is a tangent to the hyperbola $\frac{x^2}{a^2} - \frac{y^2}{16} = 1$, then which of the following cannot be sides of a right angled triangle?

(A) $2a, 4, 1$

(B) $a, 4, 1$

(C) $a, 4, 2$

(D) $2a, 8, 1$

Answer (B, C, D)

Sol. $y = 2x + 1$ be tangent to $\frac{x^2}{a^2} - \frac{y^2}{16} = 1$

$\therefore y = 2x + 1$ compare with $y = mx \pm \sqrt{a^2 m^2 - 16}$.

$\Rightarrow m = 2$ and $a^2 m^2 - 16 = 1$

$\Rightarrow 4a^2 = 17$

$\therefore 2a, 4, 1$ are the sides of right angled triangle.

40. Let X and Y be two events such that $P(X) = \frac{1}{3}$, $P(X|Y) = \frac{1}{2}$ and $P(Y|X) = \frac{2}{5}$. Then

(A) $P(X \cap Y) = \frac{1}{5}$

(B) $P(Y) = \frac{4}{15}$

(C) $P(X'|Y) = \frac{1}{2}$

(D) $P(X \cup Y) = \frac{2}{5}$

Answer (B, C)

Sol. $P(X) = \frac{1}{3}$, $P\left(\frac{X}{Y}\right) = \frac{1}{2}$, $P\left(\frac{Y}{X}\right) = \frac{2}{5}$

$$P\left(\frac{X}{Y}\right) = \frac{P(X \cap Y)}{P(Y)} = \frac{1}{2}$$

$$P\left(\frac{Y}{X}\right) = \frac{P(X \cap Y)}{P(X)} = \frac{2}{5}$$

$$\Rightarrow P(Y) = \frac{4}{15}, P(X) = \frac{1}{3}, P(X \cap Y) = \frac{2}{15}$$

$$\therefore P\left(\frac{X'}{Y}\right) = \frac{P(X' \cap Y)}{P(Y)} = \frac{P(Y) - P(X \cap Y)}{P(Y)} = \frac{\frac{4}{15} - \frac{2}{15}}{\frac{4}{15}} = \frac{1}{2}$$

$$P(X \cup Y) = \frac{1}{3} + \frac{4}{15} - \frac{2}{15} = \frac{9-2}{15} = \frac{7}{15}$$

41. Which of the following is(are) not the square of a 3×3 matrix with real entries?

(A) $\begin{bmatrix} 1 & 0 & 0 \\ 0 & 1 & 0 \\ 0 & 0 & -1 \end{bmatrix}$

(B) $\begin{bmatrix} 1 & 0 & 0 \\ 0 & 1 & 0 \\ 0 & 0 & 1 \end{bmatrix}$

(C) $\begin{bmatrix} -1 & 0 & 0 \\ 0 & -1 & 0 \\ 0 & 0 & -1 \end{bmatrix}$

(D) $\begin{bmatrix} 1 & 0 & 0 \\ 0 & -1 & 0 \\ 0 & 0 & -1 \end{bmatrix}$

Answer (A, C)

Sol. Since determinant value of matrix in option (B) & (D) are positive.

Hence it can be represented as square of a matrix, but determinant value of matrix in option (A) & (C) are negative hence, it cannot be represented as square of a matrix.

42. Let $[x]$ be the greatest integer less than or equals to x . Then, at which of the following point(s) the function $f(x) = x \cos(\pi(x + [x]))$ is discontinuous?

(A) $x = 0$

(B) $x = 1$

(C) $x = 2$

(D) $x = -1$

Answer (B, C, D)

Sol. $f(x) = x \cos(\pi(x + [x]))$

$$= \begin{cases} x \cos \pi x, [x] \text{ is even} \\ -x \cos \pi x, [x] \text{ is odd} \end{cases}$$

Clearly $f(1^+) \neq f(1)$, $f(2^+) \neq f(2)$, $f(-1^+) \neq f(-1^-)$

but $f(0) = f(0^+) = f(0) = 0$ hence f is discontinuous at $x = 1, -1, 2$ but continuous at $x = 0$.

43. If a chord, which is not a tangent, of the parabola $y^2 = 16x$ has the equation $2x + y = p$, and midpoint (h, k) , then which of the following is(are) possible value(s) of p, h and k ?

- (A) $p = 2, h = 3, k = -4$
- (B) $p = 5, h = 4, k = -3$
- (C) $p = -1, h = 1, k = -3$
- (D) $p = -2, h = 2, k = -4$

Answer (A)

Sol. Equation of chord is $2x + y = p$

For point of intersection with parabola,

$$(p - 2x)^2 = 16x$$

$$\Rightarrow 4x^2 - (4p + 16)x + p^2 = 0$$

$$\Rightarrow p = 128p + 256$$

Hence, $p = -2$

Equation of chord for midpoint (h, k)

$$yk - 8(x + h) = k^2 - 16h$$

$$\Rightarrow yk - 8x = k^2 - 8h$$

$$-8x + ky = k^2 - 8h$$

On comparing,

$$2x + y = p$$

$$-\frac{8}{2} = \frac{k}{1} = \frac{k^2 - 8h}{p}$$

$$k^2 - 8h = -4p$$

$$16 - 8h = -4p$$

$$\Rightarrow -p + 2h = 4$$

$\therefore k = -4, p = 2, h = 3$

SECTION - 2 (Maximum Marks : 15)

This section contains **FIVE** questions.

The answer to each question is a **SINGLE DIGIT INTEGER** ranging from 0 to 9, both inclusive.

For each question, darken the bubble corresponding to the correct integer in the ORS.

For each question, marks will be awarded in one of the following categories:

Full Marks : +3 If only the bubble corresponding to the correct answer is darkened.

Zero Marks : 0 In all other cases.

44. The sides of a right angled triangle are in arithmetic progression. If the triangle has area 24, then what is the length of its smallest side?

Answer (6)

Sol. Using $(\alpha + \beta)^2 = \alpha^2 + (\alpha - \beta)^2$

$$\Rightarrow \beta = \frac{\alpha}{4}$$

$$\text{Also, } \frac{1}{2}\alpha(\alpha - \beta) = 24$$

$$\Rightarrow \left. \begin{array}{l} \alpha = 8 \\ \beta = 2 \end{array} \right\}$$

Smallest side = 6

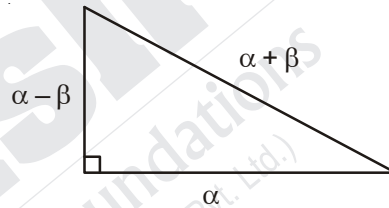

45. For a real number α , if the system
$$\begin{bmatrix} 1 & \alpha & \alpha^2 \\ \alpha & 1 & \alpha \\ \alpha^2 & \alpha & 1 \end{bmatrix} \begin{bmatrix} x \\ y \\ z \end{bmatrix} = \begin{bmatrix} 1 \\ -1 \\ 1 \end{bmatrix}$$
 of linear equations, has infinitely many solutions, then $1 + \alpha + \alpha^2 =$

Answer (1)

Sol. Equation is rewritten as $AX = B$

$$\text{where } A = \begin{bmatrix} 1 & \alpha & \alpha^2 \\ \alpha & 1 & \alpha \\ \alpha^2 & \alpha & 1 \end{bmatrix}, X = \begin{bmatrix} x \\ y \\ z \end{bmatrix}, B = \begin{bmatrix} 1 \\ -1 \\ 1 \end{bmatrix}$$

$$\Rightarrow X = \frac{\text{adj}(A) \cdot B}{\det(A)}$$

For infinite solution, $\det(A) = 0$ and $\text{adj}(A) \cdot B = 0$

$$\Rightarrow \alpha = 1, -1$$

but α is not equal to 1 as in this case equation is inconsistent.

So, $\alpha = -1$

$$\text{i.e., } \boxed{1 + \alpha + \alpha^2 = 1}$$

46. Words of length 10 are formed using the letters A, B, C, D, E, F, G, H, I, J. Let x be the number of such words where no letter is repeated; and let y be the number of such words where exactly one letter is repeated twice and no other letter is repeated. Then, $\frac{y}{9x} =$

Answer (5)

Sol. Clearly $x = 10!$

For calculating y , one letter has to be excluded, this can be done in 10 ways.

Out of the remaining 9 letters, one of them is to be repeated

$$y = {}^{10}C_1 \times {}^9C_1 \times \frac{10!}{2!} = 5 \times 9 \times 10!$$

$$\therefore \frac{y}{9x} = \frac{5 \times 9 \times 10!}{9 \times 10!} = 5$$

47. For how many values of p , the circle $x^2 + y^2 + 2x + 4y - p = 0$ and the coordinate axes have exactly three common points?

Answer (2)

Sol. Possible cases

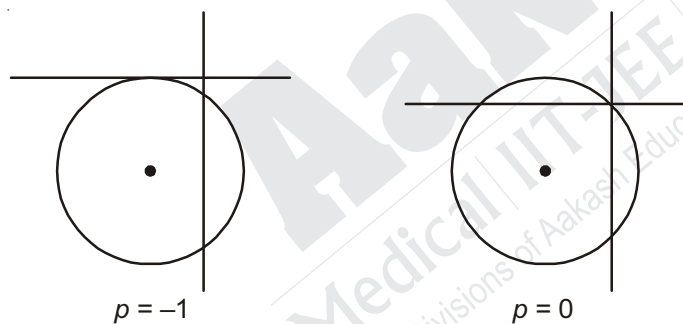

48. Let $f : \mathbb{R} \rightarrow \mathbb{R}$ be a differentiable function such that $f(0) = 0$, $f\left(\frac{\pi}{2}\right) = 3$ and $f'(0) = 1$.

$$\text{If } g(x) = \int_x^{\frac{\pi}{2}} [f'(t) \operatorname{cosec} t - \cot t \operatorname{cosec} t f(t)] dt \text{ for } x \in \left(0, \frac{\pi}{2}\right], \text{ then } \lim_{x \rightarrow 0} g(x) =$$

Answer (2)

$$\text{Sol. } g(x) = \int_x^{\frac{\pi}{2}} d((\operatorname{cosec} t)(f(t))) = \{(\operatorname{cosec} t)(f(t))\}_x^{\frac{\pi}{2}}$$

$$\text{So, } \lim_{x \rightarrow 0} g(x) = \lim_{x \rightarrow 0} \left(f\left(\frac{\pi}{2}\right) - f(x) \operatorname{cosec} x \right)$$

$$= 3 - \lim_{x \rightarrow 0} \frac{f(x)}{\sin x} = 3 - \lim_{x \rightarrow 0} \frac{f'(x)}{\cos x} = 2$$

SECTION - 3 (Maximum Marks : 18)

This section contains **SIX** questions of matching type.

This section contains **TWO** tables (each having 3 columns and 4 rows).

Based on each table, there are **THREE** questions.

Each question has **FOUR** options (A), (B), (C) and (D). **ONLY ONE** of these four options is correct.

For each question, darken the bubble corresponding to the correct option in the ORS.

For each question, marks will be awarded in one of the following categories:

Full Marks : +3 If only the bubble corresponding to the correct option is darkened

Zero Marks : 0 If none of the bubbles is darkened

Negative Marks : -1 In all other cases

Answer Q.49, Q.50 and Q.51 by appropriately matching the information given in the three columns of the following table.

Column 1, 2, and 3 contain conics, equations of tangents to the conics and points of contact, respectively.		
Column 1	Column 2	Column 3
(I) $x^2 + y^2 = a^2$	(i) $my = m^2x + a$	(P) $\left(\frac{a}{m^2}, \frac{2a}{m}\right)$
(II) $x^2 + a^2y^2 = a^2$	(ii) $y = mx + a\sqrt{m^2 + 1}$	(Q) $\left(\frac{-ma}{\sqrt{m^2 + 1}}, \frac{a}{\sqrt{m^2 + 1}}\right)$
(III) $y^2 = 4ax$	(iii) $y = mx + \sqrt{a^2m^2 - 1}$	(R) $\left(\frac{-a^2m}{\sqrt{a^2m^2 + 1}}, \frac{1}{\sqrt{a^2m^2 + 1}}\right)$
(IV) $x^2 - a^2y^2 = a^2$	(iv) $y = mx + \sqrt{a^2m^2 + 1}$	(S) $\left(\frac{-a^2m}{\sqrt{a^2m^2 - 1}}, \frac{-1}{\sqrt{a^2m^2 - 1}}\right)$

49. The tangent to a suitable conic (Column 1) at $\left(\sqrt{3}, \frac{1}{2}\right)$ is found to be $\sqrt{3}x + 2y = 4$, then which of the following options is the only correct combination?

(A) (IV) (iii) (S)

(B) (II) (iii) (R)

(C) (IV) (iv) (S)

(D) (II) (iv) (R)

Answer (D)

50. If a tangent to a suitable conic (column 1) is found to be $y = x + 8$ and its point of contact is (8, 16), then which of the following options is the only correct combination?

(A) (III) (i) (P)

(B) (I) (ii) (Q)

(C) (II) (iv) (R)

(D) (III) (ii) (Q)

Answer (A)

51. For $a = \sqrt{2}$, if a tangent is drawn to a suitable conic (Column 1) at the point of contact $(-1, 1)$, then which of the following options is the only correct combination for obtaining its equation?
- (A) (II) (ii) (Q)
 (B) (I) (i) (P)
 (C) (I) (ii) (Q)
 (D) (III) (i) (P)

Answer (C)

Solution of Q. Nos. 49 to 51

Correct combinations are

I, ii, Q

II, iv, R

III, i, P

IV, iii, S

49. Out of the given A, B are the right combination which we need to check. Out of this (Less check for) $x^2 + a^2y^2 = a^2$,

$$\left(\frac{-a^2m}{\sqrt{a^2m^2+1}}, \frac{1}{\sqrt{a^2m^2+1}} \right) = \left(\frac{+4 \times \frac{\sqrt{3}}{2}}{2}, \frac{1}{2} \right) = \left(\frac{1}{2} \right)$$

Which is given so, (D) is correct.

50. As $y = x + 8$ and its point of contact $(8, 16)$ satisfy only $y^2 = 4ax$

51. $(-1, 1)$ for $a = \sqrt{2}$ lies on

$x^2 + y^2 = a^2$, so the only correct answer is (C).

Answer Q.52, Q.53 and Q.54 by appropriately matching the information given in the three columns of the following table.

Let $f(x) = x + \log_e x - x \log_e x, x \in (0, \infty)$

- Column 1 contains information about zeros of $f(x), f'(x)$ and $f''(x)$.
- Column 2 contains information about the limiting behaviour of $f(x), f'(x)$ and $f''(x)$ at infinity.
- Column 3 contains information about increasing/decreasing nature of $f(x)$ and $f'(x)$.

Column 1	Column 2	Column 3
(I) $f(x) = 0$ for some $x \in (1, e^2)$	(i) $\lim_{x \rightarrow \infty} f(x) = 0$	(P) f is increasing in $(0, 1)$
(II) $f'(x) = 0$ for some $x \in (1, e)$	(ii) $\lim_{x \rightarrow \infty} f(x) = -\infty$	(Q) f is decreasing in (e, e^2)
(III) $f'(x) = 0$ for some $x \in (0, 1)$	(iii) $\lim_{x \rightarrow \infty} f'(x) = -\infty$	(R) f' is increasing in $(0, 1)$
(IV) $f''(x) = 0$ for some $x \in (1, e)$	(iv) $\lim_{x \rightarrow \infty} f''(x) = 0$	(S) f' is decreasing in (e, e^2)

52. Which of the following options is the only correct combination?

- (A) (I) (ii) (R) (B) (IV) (i) (S)
(C) (III) (iv) (P) (D) (II) (iii) (S)

Answer (D)

53. Which of the following options is the only correct combination?

- (A) (I) (i) (P) (B) (II) (ii) (Q)
(C) (III) (iii) (R) (D) (IV) (iv) (S)

Answer (B)

54. Which of the following options is the only incorrect combination?

- (A) (II) (iii) (P) (B) (I) (iii) (P)
(C) (III) (i) (R) (D) (II) (iv) (Q)

Answer (C)

Solution of Q. Nos. 52 to 54

$$f(x) = x + \log_e x - x \log_e x$$

(I) $f(1) = 1 + \log 1 - 1 \log 1 = 1 > 0$

$$f(e^2) = e^2 + \log_e e^2 - e^2 \log_e e^2 = e^2 + 2 - 2e^2 = 2 - e^2 < 0$$

\Rightarrow (I) is true.

(II) $f'(x) = 1 + \frac{1}{x} - \log_e x - 1$

$$f'(1) = 1$$

$$f'(e) = \frac{1}{e} - 1 < 0$$

\Rightarrow (II) is true.

(III) $f''(x) = -\frac{1}{x^2} - \frac{1}{x} < 0$ for all $x \in (0, \infty)$

So, $f'(x)$ is decreasing

So, min. of $f'(x)$ in $(0, 1)$ is $f'(1) = 1$

So, (III) is false.

(IV) $f''(1) = -2 < 0$

$$f''(e) = -\frac{1}{e^2} - \frac{1}{e} < 0$$

So, (IV) is false.

Column 2

$$\lim_{x \rightarrow \infty} f(x) = \lim_{x \rightarrow \infty} x + \log_e x - x \log_e x = \lim_{t \rightarrow 0^+} \frac{1}{t} - \log_e t + \frac{\log_e t}{t}$$

$$\lim_{t \rightarrow 0^+} \frac{1 - t \log_e t + \log_e t}{t \rightarrow 0^+} = -\infty$$

(i) is false

(ii) is true

$$(iii) \lim_{x \rightarrow \infty} f'(x) = \lim_{x \rightarrow \infty} \frac{1}{x} - \log_e x = \lim_{t \rightarrow 0^+} t + \log_e t = -\infty \text{ (True)}$$

$$(iv) \lim_{x \rightarrow \infty} f''(x) = -\frac{1}{x^2} - \frac{1}{x} = \lim_{x \rightarrow \infty} \frac{-1-x}{x^2} = 0 \text{ (True)}$$

Column 3

$$(P) f'(x) = \frac{1}{x} - \log_e x > 0 \text{ is true}$$

$$\text{for } x \in (0, 1), \frac{1}{x} \in (1, \infty)$$

$$\log_e x \in (-\infty, 0)$$

$$(Q) f'(x) = \frac{1}{x} - \log_e x \text{ is decreasing function}$$

$$f'(e) = \frac{1}{e} - 1 < 0$$

$$f'(e^2) = \frac{1}{e^2} - 2 < 0 \text{ is true}$$

$$(R) f''(x) = -\frac{1}{x} - \frac{1}{x^2} < 0 \text{ so, } f'(x) \text{ is decreasing}$$

So, (R) is false.

(S) is true.

END OF MATHEMATICS