

DATE : 21/05/2017



CODE

0

# Aakash

Medical | IIT-JEE | Foundations

(Divisions of Aakash Educational Services Pvt. Ltd.)

Regd. Office : Aakash Tower, 8, Pusa Road, New Delhi-110005

Ph.: 011-47623456 Fax : 011-47623472

Time : 3 hrs.

## Answers & Solutions

Max. Marks: 183

for

## JEE (Advanced)-2017

### PAPER - 2 (Code - 0)

#### INSTRUCTIONS

##### QUESTION PAPER FORMAT AND MARKING SCHEME :

1. The question paper has **three parts** : Physics, Chemistry and Mathematics.
2. Each part has three sections as detailed in the following table :

Section	Question Type	Number of Questions	Category-wise Marks for Each Question				Maximum Marks of the Section
			Full Marks	Partial Marks	Zero Marks	Negative Marks	
1	Single Correct Option	7	+3 If only the bubble corresponding to the correct option is darkened	—	0 If none of the bubbles is darkened	-1 In all other cases	21
2	One or more correct option(s)	7	+4 If only the bubble(s) corresponding to all the correct option(s) is(are) darkened	+1 For darkening a bubble corresponding to each correct option, provided NO incorrect option is darkened	0 If none of the bubbles is darkened	-2 In all other cases	28
3	Comprehension	4	+3 If only the bubble corresponding to the correct answer is darkened	—	0 In all other cases	—	12

**PHYSICS**

**SECTION - 1 (Maximum Marks : 21)**

This section contains **SEVEN** questions.

Each question has **FOUR** options (A), (B), (C) and (D). **ONLY ONE** of these four options is correct.

For each question, darken the bubble corresponding to the correct option in the ORS.

For each question, marks will be awarded in one of the following categories:

**Full Marks** : +3 If only the bubble corresponding to the correct option is darkened

**Zero Marks** : 0 If none of the bubbles is darkened

**Negative Marks** : -1 In all other cases

1. Consider regular polygons with number of sides  $n = 3, 4, 5, \dots$  as shown in the figure. The center of mass of all the polygons is at height  $h$  from the ground. They roll on a horizontal surface about the leading vertex without slipping and sliding as depicted. The maximum increase in height of the locus of the center of mass for each polygon is  $\Delta$ . Then  $\Delta$  depends on  $n$  and  $h$  as

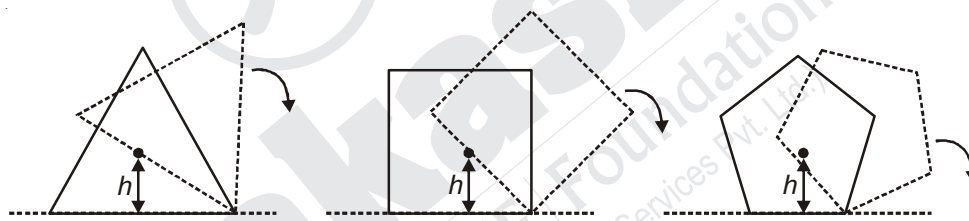

(A)  $\Delta = h \sin^2\left(\frac{\pi}{n}\right)$

(B)  $\Delta = h \sin\left(\frac{2\pi}{n}\right)$

(C)  $\Delta = h \tan^2\left(\frac{\pi}{2n}\right)$

(D)  $\Delta = h \left[ \frac{1}{\cos\left(\frac{\pi}{n}\right)} - 1 \right]$

**Answer (D)**

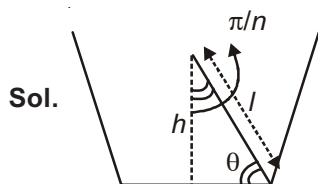

$$\theta = \frac{\pi}{2} - \frac{\pi}{n}$$

$$\sin \theta = \cos \frac{\pi}{n}$$

$$l = \frac{h}{\sin \theta}$$

$$\Delta = l - h$$

$$= h \left[ \frac{1}{\sin \theta} - 1 \right]$$

$$= h \left[ \frac{1}{\cos \frac{\pi}{n}} - 1 \right]$$

2. Consider an expanding sphere of instantaneous radius  $R$  whose total mass remains constant. The expansion is such that the instantaneous density  $\rho$  remains uniform throughout the volume. The rate of fractional change in density  $\left(\frac{1}{\rho} \frac{d\rho}{dt}\right)$  is constant. The velocity  $v$  of any point on the surface of the expanding sphere is proportional to

- (A)  $R$  (B)  $\frac{1}{R}$   
 (C)  $R^3$  (D)  $R^{2/3}$

**Answer (A)**

**Sol.**  $M = \frac{4}{3}\pi R^3 \rho$

$$0 = \frac{4}{3}\pi \left[ 3R^2 \frac{dR}{dt} \rho + R^3 \frac{d\rho}{dt} \right]$$

Dividing by  $\rho$

$$0 = 3R^2 \frac{dR}{dt} + R^3 \frac{1}{\rho} \cdot \frac{d\rho}{dt}$$

$$\frac{dR}{dt} 3R^2 = -R^3 K$$

$$\frac{dR}{dt} \propto R$$

3. A photoelectric material having work-function  $\phi_0$  is illuminated with light of wavelength  $\lambda$   $\left(\lambda < \frac{hc}{\phi_0}\right)$ . The fastest photoelectron has a de-Broglie wavelength  $\lambda_d$ . A change in wavelength of the incident light by  $\Delta\lambda$  result in a change  $\Delta\lambda_d$  in  $\lambda_d$ . Then the ratio  $\Delta\lambda_d/\Delta\lambda$  is proportional to

- (A)  $\lambda_d^2/\lambda^2$  (B)  $\lambda_d/\lambda$   
 (C)  $\lambda_d^3/\lambda$  (D)  $\lambda_d^3/\lambda^2$

**Answer (D)**

**Sol.**  $\lambda_d = \frac{h}{\sqrt{\left(\frac{hc}{\lambda} - \phi\right) 2m}}$

$$\sqrt{2m\left(\frac{hc}{\lambda} - \phi\right)} = \frac{h}{\lambda_d}$$

$$2m\left(\frac{hc}{\lambda} - f\right) = \frac{h^2}{\lambda_d^2}$$

$$2m hc \left(\frac{-1}{\lambda^2} d\lambda\right) = -\frac{h^2}{\lambda_d^3}$$

$$\frac{d\lambda_d}{d\lambda} = k \frac{\lambda_d^3}{\lambda^2}$$



$$\Rightarrow 0.01 = \frac{(15 + 1)}{300} \Delta L$$

$$\Rightarrow \Delta L = \frac{0.01 \times 300}{16}$$

$$\therefore \frac{\Delta L}{L} \times 100 = \frac{3}{16 \times 20} \times 100 = 1\%$$

6. A rocket is launched normal to the surface of the Earth, away from the Sun, along the line joining the Sun and the Earth. The Sun is  $3 \times 10^5$  times heavier than the Earth and is at a distance  $2.5 \times 10^4$  times larger than the radius of the Earth. The escape velocity from Earth's gravitational field is  $v_e = 11.2 \text{ km s}^{-1}$ . The minimum initial velocity ( $v_s$ ) required for the rocket to be able to leave the Sun-Earth system is closest to

(Ignore the rotation and revolution of the Earth and the presence of any other planet)

(A)  $v_s = 72 \text{ km s}^{-1}$

(B)  $v_s = 22 \text{ km s}^{-1}$

(C)  $v_s = 42 \text{ km s}^{-1}$

(D)  $v_s = 62 \text{ km s}^{-1}$

**Answer (C)**

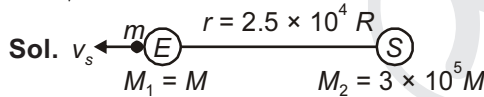

loss in KE = Gain in PE

$$\Rightarrow \frac{1}{2} m v_s^2 = \frac{GM_1 m}{R} + \frac{GM_2 m}{r}$$

$$\Rightarrow \frac{1}{2} v_s^2 = \frac{GM}{R} + \frac{G \times 3 \times 10^5 M}{2.5 \times 10^4 R}$$

$$\Rightarrow v_s = \sqrt{2 \times \frac{GM}{R} \times 13}$$

$$= 11.2 \times \sqrt{13} = 40.4 \text{ km/s}$$

$$\approx 42 \text{ km/s}$$

7. A symmetric star shaped conducting wire loop is carrying a steady state current  $I$  as shown in the figure. The distance between the diametrically opposite vertices of the star is  $4a$ . The magnitude of the magnetic field at the center of the loop is

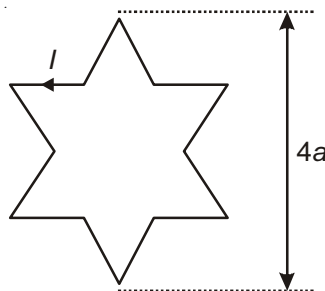

(A)  $\frac{\mu_0 I}{4\pi a} 6[\sqrt{3} - 1]$

(B)  $\frac{\mu_0 I}{4\pi a} 6[\sqrt{3} + 1]$

(C)  $\frac{\mu_0 I}{4\pi a} 3[\sqrt{3} - 1]$

(D)  $\frac{\mu_0 I}{4\pi a} 3[2 - \sqrt{3}]$

**Answer (A)**

**Sol.** Considering one section out of symmetric star shaped conducting wire loop.

**From geometry :**

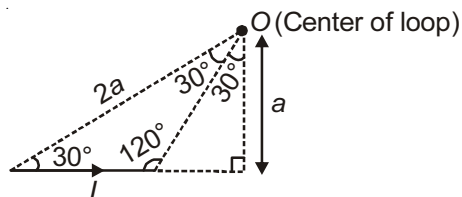

Magnetic field at the center of the loop due to all 12 identical sections is additive in nature.

$$\begin{aligned} \therefore B_{\text{net}} &= 12 \times \frac{\mu_0 I}{4\pi a} [\cos 30^\circ + \cos 120^\circ] \\ &= \frac{\mu_0 I}{4\pi a} \cdot 6 \cdot [\sqrt{3} - 1] \end{aligned}$$

**SECTION - 2 (Maximum Marks : 28)**

This section contains **SEVEN** questions.

Each question has **FOUR** options (A), (B), (C) and (D). **ONE OR MORE THAN ONE** of these four options is(are) correct.

For each question, darken the bubble(s) corresponding to all the correct option(s) in the ORS.

For each question, marks will be awarded in one of the following categories:

- Full Marks** : +4 If only the bubble(s) corresponding to all the correct option(s) is(are) darkened.
- Partial Marks** : +1 For darkening a bubble corresponding to **each correct option**, provided NO incorrect option is darkened
- Zero Marks** : 0 If none of the bubbles is darkened
- Negative Marks** : -2 In all other cases

For example, if (A), (C) and (D) are all the correct options for a question, darkening all these three will get +4 marks; darkening only (A) and (D) will get +2 marks; and darkening (A) and (B) will get -2 marks, as a wrong option is also darkened.

8. A wheel of radius  $R$  and mass  $M$  is placed at the bottom of a fixed step of height  $R$  as shown in the figure. A constant force is continuously applied on the surface of the wheel so that it just climbs the step without slipping. Consider the torque  $\tau$  about an axis normal to the plane of the paper passing through the point Q. Which of the following options is/are correct?

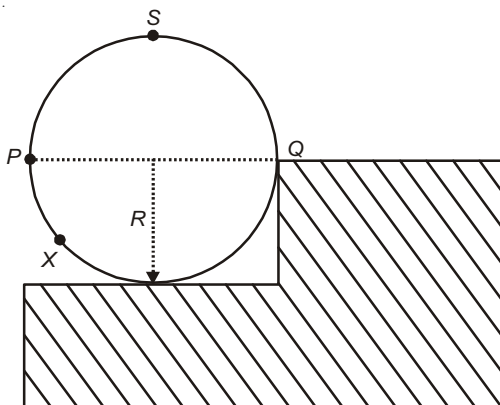

- (A) If the force is applied normal to the circumference at point  $P$  then  $\tau$  is zero
- (B) If the force is applied tangentially at point  $S$  then  $\tau \neq 0$  but the wheel never climbs the step
- (C) If the force is applied at point  $P$  tangentially then  $\tau$  decreases continuously as the wheel climbs
- (D) If the force is applied normal to the circumference at point  $X$  then  $\tau$  is constant

**Answer (A, D)**

**Sol.** Correct options (A, D) [Treating magnitude of force constant]

**For option (A):**

Applied force passes through point  $Q$ .

So, its torque is zero.

**For option (D):**

Torque due to applied force at  $x$  remains constant.

9. Two coherent monochromatic point sources  $S_1$  and  $S_2$  of wavelength  $\lambda = 600$  nm are placed symmetrically on either side of the centre of the circle as shown. The sources are separated by a distance  $d = 1.8$  mm. This arrangement produces interference fringes visible as alternate bright and dark spots on the circumference of the circle. The angular separation between two consecutive bright spots is  $\Delta\theta$ . Which of the following options is/are correct?

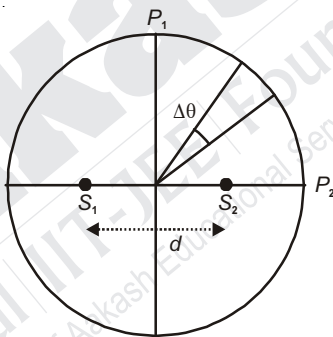

- (A) The angular separation between two consecutive bright spots decreases as we move from  $P_1$  to  $P_2$  along the first quadrant
- (B) A dark spot will be formed at the point  $P_2$
- (C) The total number of fringes produced between  $P_1$  and  $P_2$  in the first quadrant is close to 3000
- (D) At  $P_2$  the order of the fringe will be maximum

**Answer (C, D)**

**Sol.**  $d = 1.8 \times 10^{-3}$  m  
 $= 18 \times 10^{-4}$  m

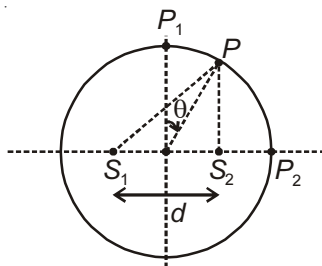

and  $\lambda = 6 \times 10^{-7} \text{ m}$

Path difference at point  $P$  (as shown)

$\Delta x = S_1P - S_2P = d \sin \theta$ , where  $\theta$  angle is measured from vertical line as shown.

For bright fringe  $d \sin \theta = m\lambda$  ... (i)

Point  $P_1$  is the point of central maxima.

At point  $P_2$ , path difference  $(\Delta x) = d$

If  $P_2$  is the point of bright fringe, then

$$d = m\lambda \Rightarrow m = \frac{d}{\lambda} = 3000$$

On differentiating equation (i)

$d \cos \theta (\Delta\theta) = (\Delta m) \lambda = \text{constant}$  for consecutive bright fringe

$\cos \theta \downarrow \therefore \Delta\theta \uparrow$  as  $\theta$  varies from 0 to  $\frac{\pi}{2}$

10. A point charge  $+Q$  is placed just outside an imaginary hemispherical surface of radius  $R$  as shown in the figure. Which of the following statements is/are correct?

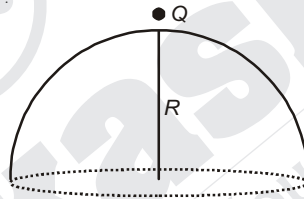

- (A) The electric flux passing through the *curved* surface of the hemisphere is  $-\frac{Q}{2\epsilon_0} \left(1 - \frac{1}{\sqrt{2}}\right)$
- (B) The component of the electric field normal to the flat surface is constant over the surface
- (C) Total flux through the curved and the flat surfaces is  $\frac{Q}{\epsilon_0}$
- (D) The circumference of the flat surface is an equipotential

**Answer (A, D)**

**Sol.** Net flux through curved surface and flat surface = 0

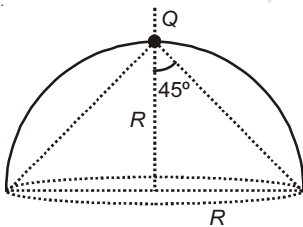

$$\Rightarrow \phi_{\text{Curved}} = -\phi_{\text{Plane}}$$

$$= -\left[ \frac{Q}{2\epsilon_0} (1 - \cos\theta) \right]$$

$$= -\left[ \frac{Q}{2\epsilon_0} \left(1 - \frac{1}{\sqrt{2}}\right) \right]$$

The circumference points are equidistant from  $Q$

$\therefore$  All points will be at the same potential.

$\therefore$  Option (A) and (D) are correct.

11. A rigid uniform bar  $AB$  of length  $L$  is slipping from its vertical position on a frictionless floor (as shown in the figure). At some instant of time, the angle made by the bar with the vertical is  $\theta$ . Which of the following statements about its motion is/are correct?

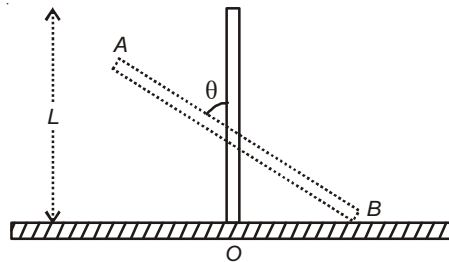

- (A) Instantaneous torque about the point in contact with the floor is proportional to  $\sin\theta$
- (B) The trajectory of the point  $A$  is a parabola
- (C) The midpoint of the bar will fall vertically downward
- (D) When the bar makes an angle  $\theta$  with the vertical, the displacement of its midpoint from the initial position is proportional to  $(1 - \cos\theta)$

**Answer (A, C, D)**

**Sol.** Torque about  $O$ , at any instant is  $mg \cdot \frac{l}{2} \sin\theta$ .

$\therefore$  Option (A)

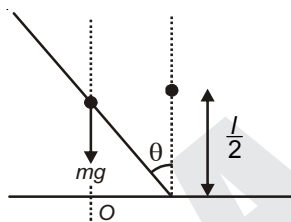

As no external force acts along  $x$ -axis, therefore centre of mass will fall vertically downward.

$\therefore$  Option (C)

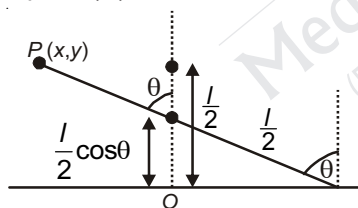

Displacement of centre of mass along  $y$ -axis

$$= \frac{l}{2} [1 - \cos\theta]$$

$\therefore$  Option (D)

$$x = -\frac{l}{2} \sin\theta, \quad y = l \cos\theta$$

$$\Rightarrow \left(-\frac{2x}{l}\right)^2 + \frac{y^2}{l^2} = 1$$

$\Rightarrow$  Trajectory is not parabola

12. A source of constant voltage  $V$  is connected to a resistance  $R$  and two ideal inductors  $L_1$  and  $L_2$  through a switch  $S$  as shown. There is no mutual inductance between the two inductors. The switch  $S$  is initially open. At  $t = 0$ , the switch is closed and current begins to flow. Which of the following options is/are correct?

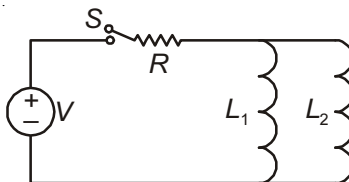

- (A) After a long time, the current through  $L_1$  will be  $\frac{V L_2}{R L_1 + L_2}$
- (B) After a long time, the current through  $L_2$  will be  $\frac{V L_1}{R L_1 + L_2}$
- (C) The ratio of the currents through  $L_1$  and  $L_2$  is fixed at all times ( $t > 0$ )
- (D) At  $t = 0$ , the current through the resistance  $R$  is  $\frac{V}{R}$

**Answer (A, B, C)**

**Sol.** Final current through battery =  $\frac{V}{R}$

$$\therefore \text{Current through } L_1 = \frac{V}{R} \left( \frac{L_2}{L_1 + L_2} \right)$$

$$\text{Current through } L_2 = \frac{V}{R} \left( \frac{L_1}{L_1 + L_2} \right)$$

At  $t = 0$  current through source = zero

$$\text{At any time } i = \frac{V}{R} + \left( 0 - \frac{V}{R} \right) e^{\frac{-tR}{\left( \frac{L_1 L_2}{L_1 + L_2} \right)}}$$

$$\therefore \text{Current through } L_1 = i \frac{L_2}{L_1 + L_2} = i_1$$

$$\text{Current through } L_2 = \frac{i L_1}{L_1 + L_2} = i_2$$

$$\frac{i_1}{i_2} = \frac{L_2}{L_1}$$

13. A uniform magnetic field  $B$  exists in the region between  $x = 0$  and  $x = \frac{3R}{2}$  (region 2 in the figure) pointing normally into the plane of the paper. A particle with charge  $+Q$  and momentum  $p$  directed along  $x$ -axis enters region 2 from region 1 at point  $P_1$  ( $y = -R$ ). Which of the following option(s) is/are correct?

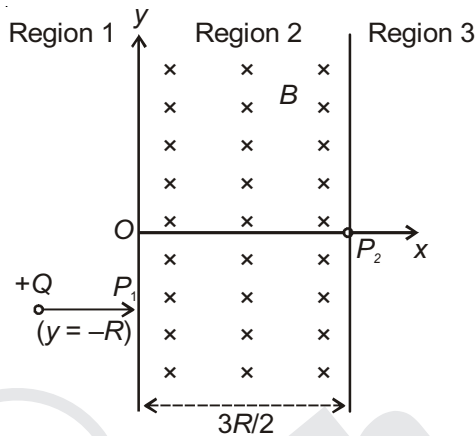

- (A) When the particle re-enters region 1 through the longest possible path in region 2, the magnitude of the change in its linear momentum between point  $P_1$  and the farthest point from  $y$ -axis is  $p/\sqrt{2}$
- (B) For  $B = \frac{8}{13} \frac{p}{QR}$ , the particle will enter region 3 through the point  $P_2$  on  $x$ -axis
- (C) For  $B > \frac{2}{3} \frac{p}{QR}$ , the particle will re-enter region 1
- (D) For a fixed  $B$ , particles of same charge  $Q$  and same velocity  $v$ , the distance between the point  $P_1$  and the point of re-entry into region 1 is inversely proportional to the mass of the particle

**Answer (B, C)**

**Sol.** The particle will follow circular trajectory inside the magnetic field region. The magnetic field cannot change the magnitude of velocity and momentum.

For longest possible path, the radius of circular motion can be  $\frac{3R}{2}$ .

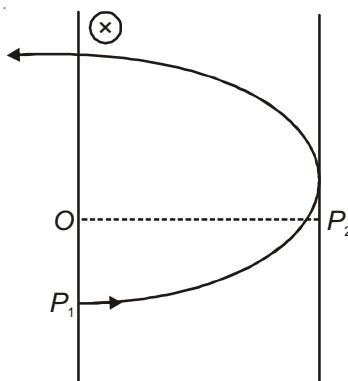

At farthest point from  $y$ -axis, the momentum is directed upwards.

$$\therefore |\Delta \vec{p}| = \sqrt{2}p$$

The radius and hence separation between  $p_1$  and re-entry point is proportional to  $m$ , if  $Q, v, B$  are same.

The particle will return to region only if it completes the half circle.

$$r \leq \frac{3R}{2}$$

$$\frac{mV}{B} \leq \frac{3R}{2}$$

$$\frac{p}{QB} \leq \frac{3R}{2}$$

$$B \geq \frac{2p}{3QR}$$

$$\text{If } B = \frac{8p}{13QR}; r = \frac{p}{QB} = \frac{13R}{8}$$

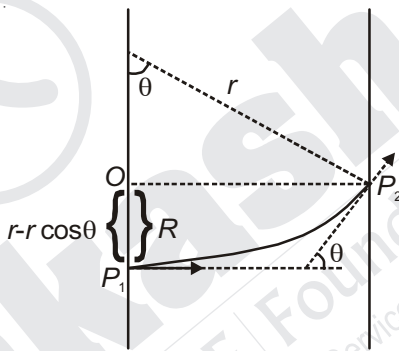

It passes through point  $P_2$  if  $r - r \cos \theta = R$

$$\sin \theta = \frac{3R}{r} = \frac{12}{13}$$

$$\frac{13R}{8} \left( 1 - \frac{5}{13} \right) = R$$

$$R = R$$

14. The instantaneous voltages at three terminals marked X, Y and Z are given by

$$V_x = V_0 \sin \omega t,$$

$$V_y = V_0 \sin \left( \omega t + \frac{2\pi}{3} \right) \text{ and}$$

$$V_z = V_0 \sin \left( \omega t + \frac{4\pi}{3} \right)$$

An ideal voltmeter is configured to read rms value of the potential difference between its terminals. It is connected between points X and Y and then between Y and Z. The reading(s) of the voltmeter will be

(A)  $V_{YZ}^{\text{rms}} = V_0 \sqrt{\frac{1}{2}}$

(B)  $V_{XY}^{\text{rms}} = V_0 \sqrt{\frac{3}{2}}$

(C) Independent of the choice of the two terminals

(D)  $V_{XY}^{\text{rms}} = V_0$

Answer (B, C)

Sol.  $V_{XY} = V_0 \sin \omega t - V_0 \sin\left(\omega t + \frac{2\pi}{3}\right)$

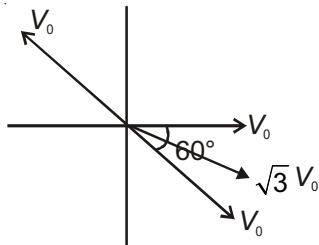

$$V_{XY}^{rms} = \frac{\sqrt{3}V_0}{\sqrt{2}}$$

$$V_{YZ} = V_0 \sin\left(\omega t + \frac{2\pi}{3}\right) - V_0 \sin\left(\omega t + \frac{4\pi}{3}\right)$$

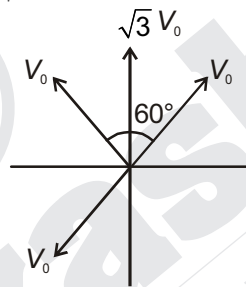

$$V_{YZ}^{rms} = \frac{\sqrt{3}V_0}{\sqrt{2}}$$

∴ B, C

**SECTION - 3 (Maximum Marks : 12)**

This section contains **TWO** Paragraphs.

Based on each paragraph, there are **TWO** questions.

Each question has **FOUR** options (A), (B), (C) and (D). **ONLY ONE** of these four options is correct.

For each question, darken the bubble(s) corresponding to the correct option in the ORS.

For each question, marks will be awarded in one of the following categories:

*Full Marks* : +3 If only the bubble corresponding to the correct option is darkened

*Zero Marks* : 0 In all other cases

**PARAGRAPH 1**

Consider a simple *RC* circuit as shown in Figure 1.

Process 1: In the circuit the switch *S* is closed at  $t = 0$  and the capacitor is fully charged to voltage  $V_0$  (i.e., charging continues for time  $T \gg RC$ ). In the process some dissipation ( $E_D$ ) occurs across the resistance  $R$ . The amount of energy finally stored in the fully charged capacitor is  $E_C$ .

Process 2: In a different process the voltage is first set to  $\frac{V_0}{3}$  and maintained for a charging time  $T \gg RC$ . Then

the voltage is raised to  $\frac{2V_0}{3}$  without discharging the capacitor and again maintained for a time  $T \gg RC$ . The process is repeated one more time by raising the voltage to  $V_0$  and the capacitor is charged to the same final voltage  $V_0$  as in Process 1.

These two processes are depicted in Figure 2.

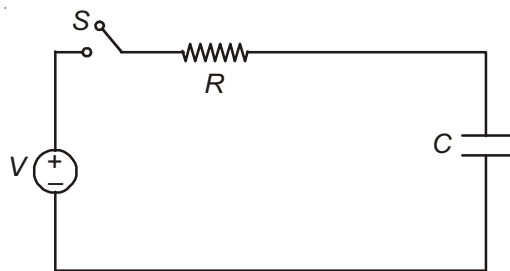

Figure 1

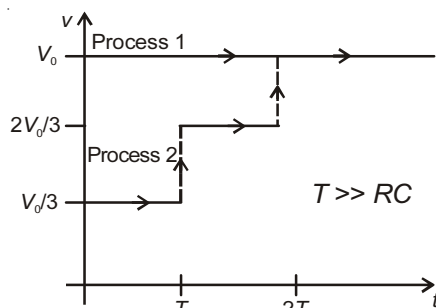

Figure 2

15. In Process 1, the energy stored in the capacitor  $E_C$  and heat dissipated across resistance  $E_D$  are related by :

(A)  $E_C = E_D \ln 2$

(B)  $E_C = E_D$

(C)  $E_C = 2E_D$

(D)  $E_C = \frac{1}{2}E_D$

**Answer (B)**

**Sol.** Final charge on capacitor =  $CV$

$$W_b = CV^2$$

$$E_c = \frac{1}{2}CV^2$$

$$E_D = W_b - \Delta E_c$$

$$= CV^2 - \frac{1}{2}CV^2$$

$$= \frac{1}{2}CV^2$$

$$\boxed{E_C = E_D}$$

16. In Process 2, total energy dissipated across the resistance  $E_D$  is :

(A)  $E_D = \frac{1}{3} \left( \frac{1}{2} CV_0^2 \right)$

(B)  $E_D = 3 \left( \frac{1}{2} CV_0^2 \right)$

(C)  $E_D = 3CV_0^2$

(D)  $E_D = \frac{1}{2} CV_0^2$

**Answer (A)**

**Sol.**  $E_D = W_b - \Delta V$

$$= \frac{CV_0}{3} \left[ \frac{V_0}{3} + \frac{2V_0}{3} + V_0 \right] - \frac{1}{2} CV_0^2$$

$$= \frac{CV_0}{3} \left[ \frac{V_0 + 2V_0 + 3V_0}{3} \right] - \frac{1}{2} CV_0^2$$

$$= \frac{CV_0}{3} [2V_0] - \frac{1}{2} CV_0^2$$

$$= \left( \frac{2}{3} - \frac{1}{2} \right) CV_0^2$$

$$= \frac{CV_0^2}{6}$$

**PARAGRAPH 2**

One twirls a circular ring (of mass  $M$  and radius  $R$ ) near the tip of one's finger as shown in Figure 1. In the process the finger never loses contact with the inner rim of the ring. The finger traces out the surface of a cone, shown by the dotted line. The radius of the path traced out by the point where the ring and the finger is in contact is  $r$ . The finger rotates with an angular velocity  $\omega_0$ . The rotating ring *rolls without slipping* on the outside of a smaller circle described by the point where the ring and the finger is in contact (Figure 2). The coefficient of friction between the ring and the finger is  $\mu$  and the acceleration due to gravity is  $g$ .

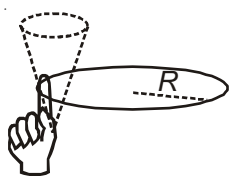

Figure 1

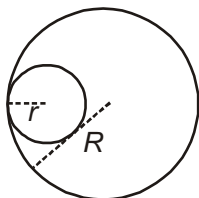

Figure 2

17. The total kinetic energy of the ring is

(A)  $M\omega_0^2(R-r)^2$

(B)  $\frac{1}{2}M\omega_0^2(R-r)^2$

(C)  $M\omega_0^2R^2$

(D)  $\frac{3}{2}M\omega_0^2(R-r)^2$

**Answer (C)**

**Sol.**  $k = \frac{1}{2}Mv_c^2 + \frac{1}{2}I_c\omega^2$

$$= \frac{1}{2}M\omega_0^2(R-r)^2 + \frac{1}{2}MR^2\omega_0^2$$

$$= \frac{1}{2}M\omega_0^2R^2\left(1 - \frac{r}{R}\right)^2 + \frac{1}{2}M\omega_0^2R^2$$

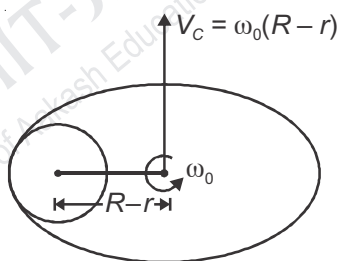

$r \ll R$

$\frac{r}{R} \rightarrow 0$

$$k = \frac{1}{2}M\omega_0^2R^2 + \frac{1}{2}M\omega_0^2R^2$$

$$= M\omega_0^2R^2$$

18. The minimum value of  $\omega_0$  below which the ring will drop down is

(A)  $\sqrt{\frac{g}{2\mu(R-r)}}$

(B)  $\sqrt{\frac{3g}{2\mu(R-r)}}$

(C)  $\sqrt{\frac{g}{\mu(R-r)}}$

(D)  $\sqrt{\frac{2g}{\mu(R-r)}}$

**Answer (C)**

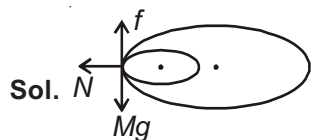

$$N = M\omega^2 (R - r)$$

$$f = Mg$$

$$f \leq \mu N$$

$$Mg \leq \mu M\omega^2 (R - r)$$

$$\omega_0 = \sqrt{\frac{g}{\mu(R - r)}}$$

**END OF PHYSICS**

  
**Aakash**  
Medical | IIT-JEE | Foundations  
(Divisions of Aakash Educational Services Pvt. Ltd.)

# CHEMISTRY

## SECTION - 1 (Maximum Marks : 21)

This section contains **SEVEN** questions.

Each question has **FOUR** options (A), (B), (C) and (D). **ONLY ONE** of these four options is correct.

For each question, darken the bubble corresponding to the correct option in the ORS.

For each question, marks will be awarded in one of the following categories:

**Full Marks** : +3 If only the bubble corresponding to the correct option is darkened

**Zero Marks** : 0 If none of the bubbles is darkened

**Negative Marks** : -1 In all other cases

19. The order of basicity among the following compounds is

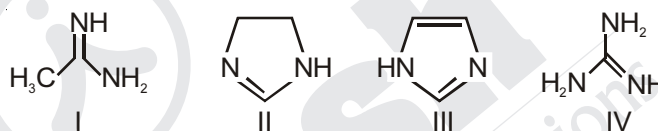

(A) IV > I > II > III

(C) I > IV > III > II

(B) IV > II > III > I

(D) II > I > IV > III

**Answer (A)**

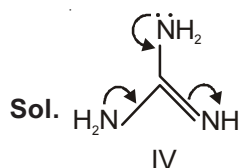

Resonance with two  $\text{-NH}_2$  groups increases electron density on 'N' of  $\text{=NH}$

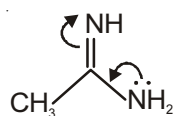

Lesser increase of electron density on  $\text{=NH}$  due to only one resonance with one  $\text{-NH}_2$

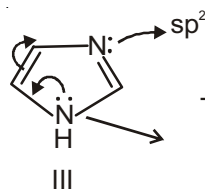

This  $\text{LPe}^-$  is not available as it is involve in aromatic Sextet. 'N' is bonded to  $\text{sp}^2$  C on both sides.

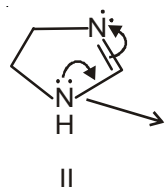

This  $\text{LPe}^-$  is not involve in aromaticity. So more available Also, 'N' is bonded to  $\text{sp}^3$  C on one side.

$\therefore$  IV > I > II > III

20. The major product of the following reaction is

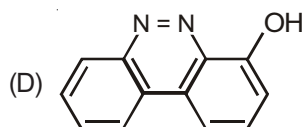
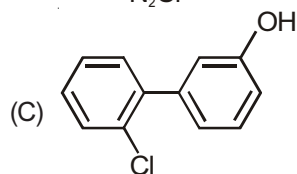
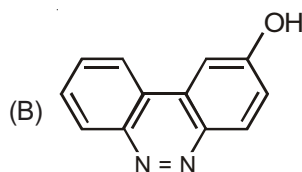
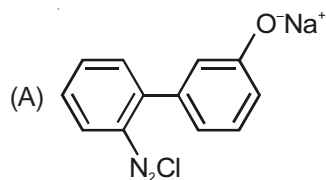
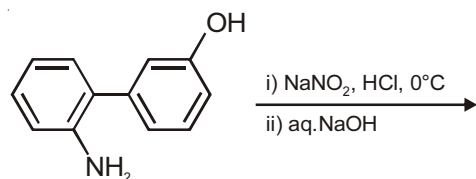

Answer (B)

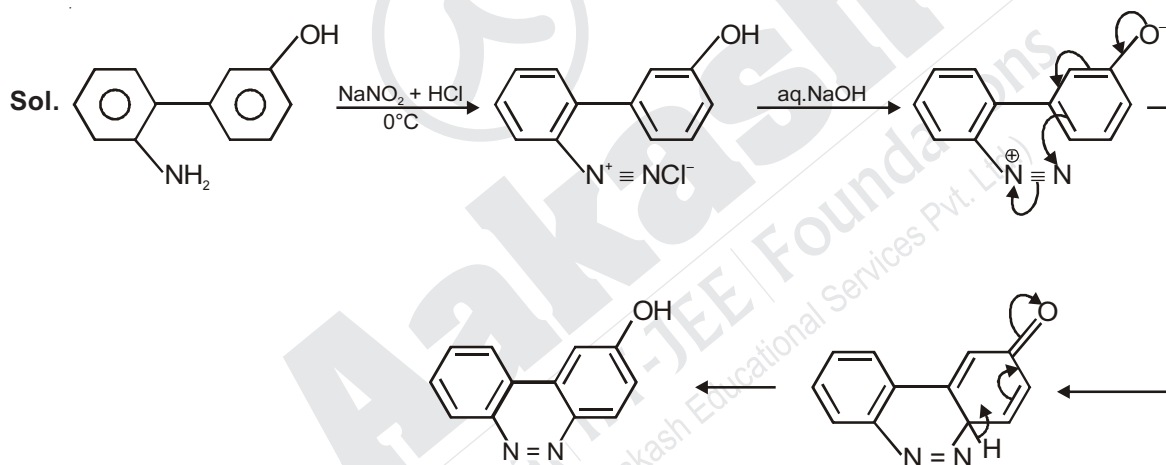

21. Which of the following combination will produce  $\text{H}_2$  gas?

(A) Au metal and  $\text{NaCN}(\text{aq})$  in the presence of air

(B) Zn metal and  $\text{NaOH}(\text{aq})$

(C) Fe Metal and conc.  $\text{HNO}_3$

(D) Cu metal and conc.  $\text{HNO}_3$

Answer (B)

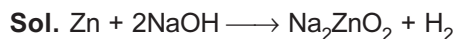

Iron become passive with conc.  $\text{HNO}_3$ .

Copper liberate  $\text{NO}_2$  with  $\text{HNO}_3$

22. The standard state Gibbs free energies of formation of C(graphite) and C(diamond) at  $T = 298 \text{ K}$  are

$$\Delta_f G^\circ[\text{C}(\text{graphite})] = 0 \text{ kJ mol}^{-1}$$

$$\Delta_f G^\circ[\text{C}(\text{diamond})] = 2.9 \text{ kJ mol}^{-1}$$

The standard state means that the pressure should be 1 bar, and substance should be pure at a given temperature. The conversion of graphite [C(graphite)] to diamond [C(diamond)] reduces its volume by  $2 \times 10^{-6} \text{ m}^3 \text{ mol}^{-1}$ . If C(graphite) is converted to C(diamond) isothermally at  $T = 298 \text{ K}$ , the pressure at which C(graphite) is in equilibrium with C(diamond), is

[Useful information :  $1 \text{ J} = 1 \text{ kg m}^2 \text{ s}^{-2}$ ;  $1 \text{ Pa} = 1 \text{ kg m}^{-1} \text{ s}^{-2}$ ;  $1 \text{ bar} = 10^5 \text{ Pa}$ ]

(A) 14501 bar

(B) 29001 bar

(C) 1450 bar

(D) 58001 bar

**Answer (A)**

**Sol.**  $\Delta G^\circ = \Delta V \cdot \Delta P$

$$\Rightarrow 2900 = 2 \times 10^{-6} \Delta P$$

$$\Rightarrow \Delta P = \frac{2900 \times 10^6}{2} \text{ Pa}$$

$$P_{F-1} = 14500 \text{ bar}$$

$$\Rightarrow P_F = 14501 \text{ bar}$$

23. The order of the oxidation state of the phosphorus atom in  $\text{H}_3\text{PO}_2$ ,  $\text{H}_3\text{PO}_4$ ,  $\text{H}_3\text{PO}_3$  and  $\text{H}_4\text{P}_2\text{O}_6$  is

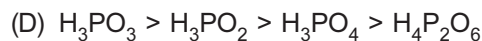
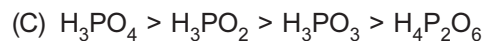
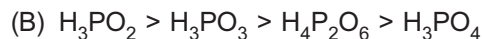
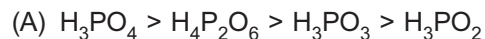
**Answer (A)**

**Sol.** Oxidation state

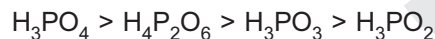

24. For the following cell,



when the concentration of  $\text{Zn}^{2+}$  is 10 times the concentration of  $\text{Cu}^{2+}$ , the expression for  $\Delta G$  (in  $\text{J mol}^{-1}$ ) is

[F is Faraday constant; R is gas constant; T is temperature;  $E^\circ(\text{cell}) = 1.1 \text{ V}$ ]

(A)  $2.303RT - 2.2F$

(B)  $1.1F$

(C)  $-2.2F$

(D)  $2.303RT + 1.1F$

**Answer (A)**

**Sol.**  $\text{Zn} \mid \text{ZnSO}_4 \parallel \text{CuSO}_4 \mid \text{Cu}$   
(aq) (aq)

$$\Delta G = \Delta G^\circ + RT \ln Q$$

$$\Delta G = \Delta G^\circ + 2.303 RT \log Q \quad \left( Q = \frac{[\text{Zn}^{2+}]}{[\text{Cu}^{2+}]} = \frac{10}{1} \right)$$

$$\Delta G^\circ = -nF E^\circ_{\text{Cell}}$$

$$= -2F \times 1.1$$

$$= -2.2 F$$

$$\Delta G = -2.2 F + 2.303 RT \log \frac{10}{1}$$

$$\boxed{\Delta G = 2.303 RT - 2.2 F}$$

25. Pure water freezes at 273 K and 1 bar. The addition of 34.5 g of ethanol to 500 g of water changes the freezing point of the solution. Use the freezing point depression constant of water as  $2 \text{ K kg mol}^{-1}$ . The figures shown below represent plots of vapour pressure (V.P.) versus temperature (T). [molecular weight of ethanol is  $46 \text{ g mol}^{-1}$ ]

Among the following, the option representing change in the freezing point is

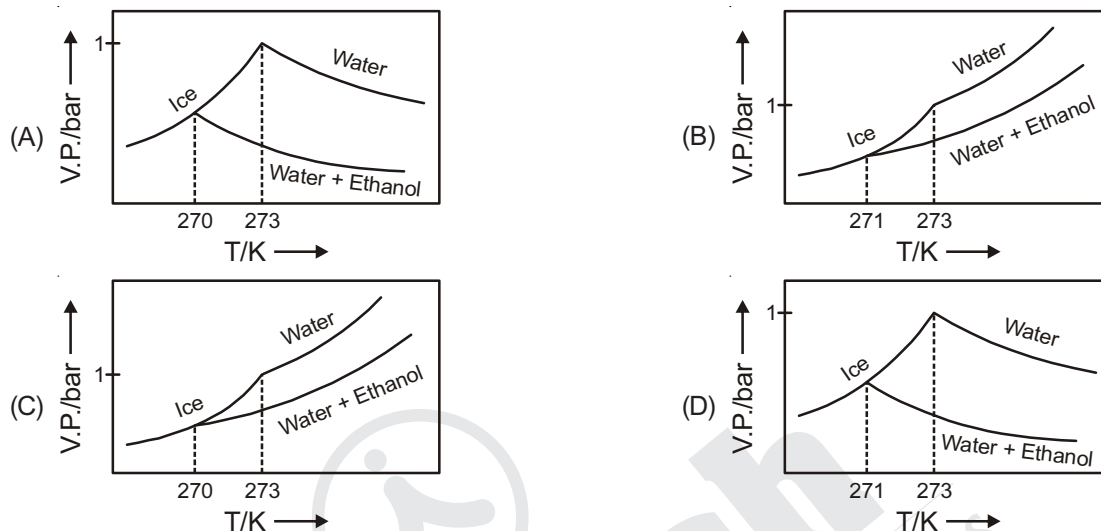

**Answer (C)**

$$\begin{aligned} \text{Sol. } \Delta T_f &= iK_f \left[ \frac{W_2 \times 1000}{M_2 \times W_1} \right] \\ &= 1 \times 2 \left[ \frac{34.5 \times 1000}{46 \times 500} \right] \\ &= 3 \text{ K} \end{aligned}$$

$$273 \text{ (K)} - T_f = 3 \text{ (K)}$$

$$\Rightarrow T_f = 270 \text{ K}$$

Also, with decrease in temperature, V.P. decreases.

$\therefore$  Graph (C) is correct.

## SECTION - 2 (Maximum Marks : 28)

This section contains **SEVEN** questions.

Each question has **FOUR** options (A), (B), (C) and (D). **ONE OR MORE THAN ONE** of these four options is(are) correct.

For each question, darken the bubble(s) corresponding to all the correct option(s) in the ORS.

For each question, marks will be awarded in one of the following categories:

**Full Marks** : +4 If only the bubble(s) corresponding to all the correct option(s) is(are) darkened.

**Partial Marks** : +1 For darkening a bubble corresponding to **each correct option**, provided NO incorrect option is darkened

**Zero Marks** : 0 If none of the bubbles is darkened

**Negative Marks** : -2 In all other cases

For example, if (A), (C) and (D) are all the correct options for a question, darkening all these three will get +4 marks; darkening only (A) and (D) will get +2 marks; and darkening (A) and (B) will get -2 marks, as a wrong option is also darkened.

26. In a bimolecular reaction, the steric factor  $P$  was experimentally determined to be 4.5. The correct option(s) among the following is(are)
- (A) The activation energy of the reaction is unaffected by the value of the steric factor  
 (B) Since  $P = 4.5$ , the reaction will not proceed unless an effective catalyst is used  
 (C) The value of frequency factor predicted by Arrhenius equation is higher than that determined experimentally  
 (D) Experimentally determined value of frequency factor is higher than that predicted by Arrhenius equation

**Answer (A, D)**

**Sol.** Steric factor =  $\frac{A_{\text{experimental}}}{A_{\text{calculated}}}$

Steric factor = 4.5

It means  $A_{\text{experimental}} > A_{\text{calculated}}$

[This seems that reaction occurs more quickly than particles collide, thus concept of steric factor was introduced]

27. For a reaction taking place in a container in equilibrium with its surroundings, the effect of temperature on its equilibrium constant  $K$  in terms of change in entropy is described by
- (A) With increase in temperature, the value of  $K$  for exothermic reaction decreases because favourable change in entropy of the surroundings decreases  
 (B) With increase in temperature, the value of  $K$  for exothermic reaction decreases because the entropy change of the system is positive  
 (C) With increase in temperature, the value of  $K$  for endothermic reaction increases because the entropy change of the system is negative  
 (D) With increase in temperature, the value of  $K$  for endothermic reaction increases because unfavourable change in entropy of the surroundings decreases

**Answer (A, B, D)**

**Sol.** Whether reaction is endothermic or exothermic in forward direction increase in temperature cause intake of heat from surrounding to system in endothermic direction due to which entropy change in system is positive and  $\Delta S$  of surrounding is negative.

28. The correct statement(s) about surface properties is(are)
- (A) Adsorption is accompanied by decrease in enthalpy and decrease in entropy of the system  
 (B) Cloud is an emulsion type of colloid in which liquid is dispersed phase and gas is dispersion medium  
 (C) The critical temperatures of ethane and nitrogen are 563 K and 126 K, respectively. The adsorption of ethane will be more than that of nitrogen on same amount of activated charcoal at a given temperature  
 (D) Brownian motion of colloidal particles does not depend on the size of the particles but depends on viscosity of the solution

**Answer (A, C)**

**Sol.** Adsorption is an exothermic process and is accompanied by decrease in entropy,

$$\Delta H_{\text{sys}} < 0, \Delta S_{\text{sys}} < 0$$

More is critical temperature ( $T_c$ ), more are intermolecular forces of attraction.

$\therefore$  More is extent of adsorption.

29. Among the following, the correct statement(s) is(are)
- (A)  $\text{AlCl}_3$  has the three-centre two-electron bonds in its dimeric structure  
 (B)  $\text{BH}_3$  has the three-centre two-electron bonds in its dimeric structure  
 (C)  $\text{Al}(\text{CH}_3)_3$  has the three-centre two-electron bonds in its dimeric structure  
 (D) The Lewis acidity of  $\text{BCl}_3$  is greater than that of  $\text{AlCl}_3$

**Answer (B, C, D)**

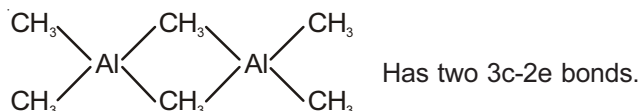
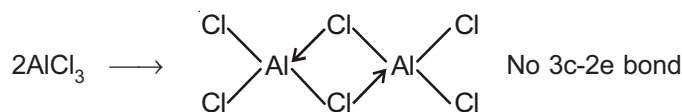
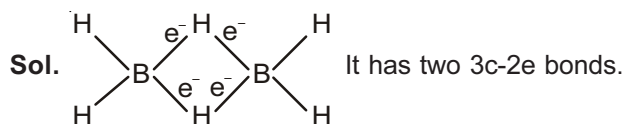

Also  $\text{BCl}_3$  is stronger lewis acid than  $\text{AlCl}_3$ .

30. For the following compounds, the correct statement(s) with respect to nucleophilic substitution reaction is(are)

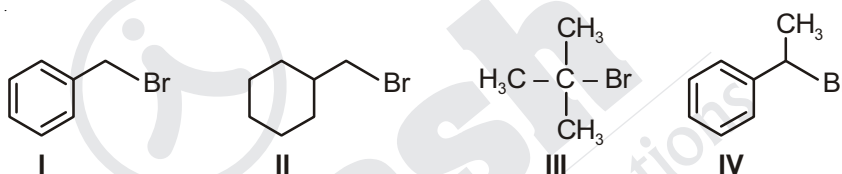

- (A) I and III follow  $\text{S}_{\text{N}}1$  mechanism  
 (B) Compound IV undergoes inversion of configuration  
 (C) The order of reactivity for I, III and IV is : IV > I > III  
 (D) I and II follow  $\text{S}_{\text{N}}2$  mechanism

**Answer (A, B, D)**

**Sol.** When medium is highly polar and protic I & III will follow  $\text{S}_{\text{N}}1$ .

Hence, (A) is correct.

Option (B) is correct as

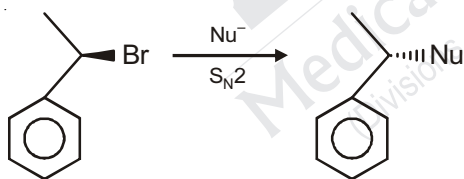

Inversion in case of  $\text{S}_{\text{N}}2$ .

- (D) I & II will follow  $\text{S}_{\text{N}}2$  when medium is polar aprotic and nucleophile is strong in high concentration.  
 (C) is incorrect for both  $\text{S}_{\text{N}}1$  and  $\text{S}_{\text{N}}2$  conditions.

31. The option(s) with only amphoteric oxides is(are)

- (A)  $\text{ZnO}$ ,  $\text{Al}_2\text{O}_3$ ,  $\text{PbO}$ ,  $\text{PbO}_2$   
 (B)  $\text{Cr}_2\text{O}_3$ ,  $\text{CrO}$ ,  $\text{SnO}$ ,  $\text{PbO}$   
 (C)  $\text{Cr}_2\text{O}_3$ ,  $\text{BeO}$ ,  $\text{SnO}$ ,  $\text{SnO}_2$   
 (D)  $\text{NO}$ ,  $\text{B}_2\text{O}_3$ ,  $\text{PbO}$ ,  $\text{SnO}_2$

**Answer (A, C)**

**Sol.**  $\text{ZnO}$ ,  $\text{Al}_2\text{O}_3$ ,  $\text{PbO}$ ,  $\text{PbO}_2$ ,  $\text{Cr}_2\text{O}_3$ ,  $\text{BeO}$ ,  $\text{SnO}$  and  $\text{SnO}_2$  are amphoteric oxides.

$\text{NO}$  is neutral oxide

$\text{CrO}$  is basic oxide

$\text{B}_2\text{O}_3$  is acidic oxide

32. Compounds **P** and **R** upon ozonolysis produce **Q** and **S**, respectively. The molecular formula of **Q** and **S** is  $C_8H_8O$ . **Q** undergoes Cannizzaro reaction but not haloform reaction, whereas **S** undergoes haloform reaction but not Cannizzaro reaction

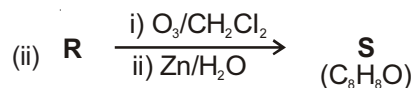
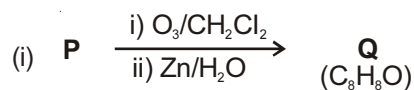

The option(s) with suitable combination of **P** and **R**, respectively, is(are)

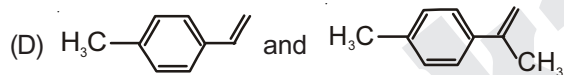
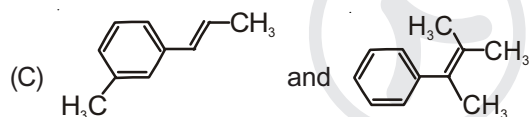
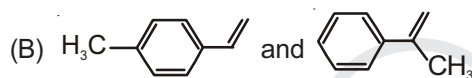
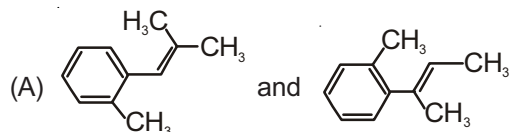

**Answer (B, C)**

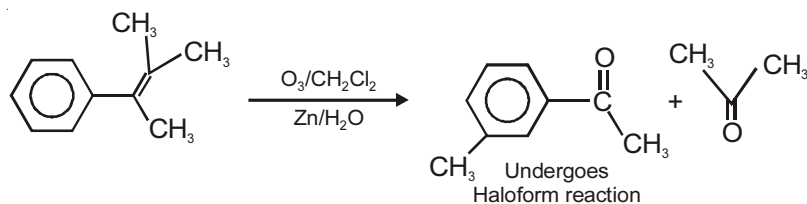
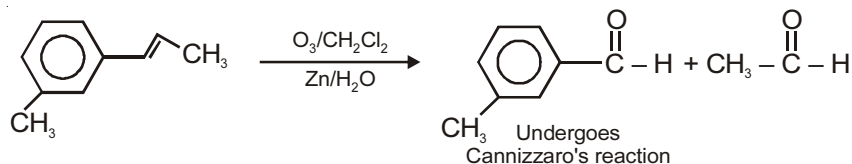
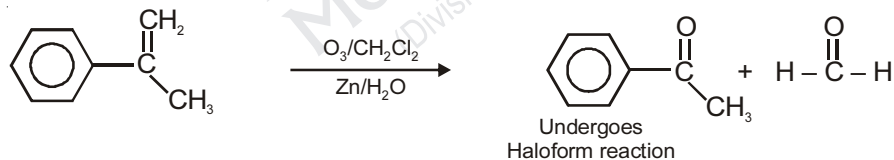
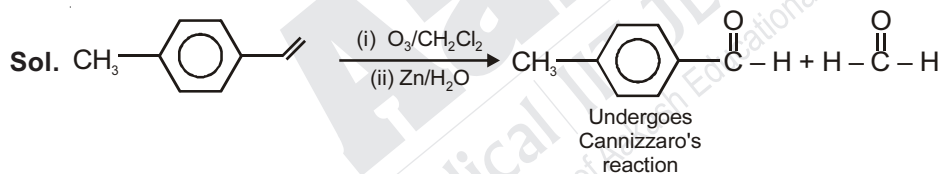

**SECTION - 3 (Maximum Marks : 12)**

This section contains **TWO** Paragraphs.

Based on each paragraph, there are **TWO** questions.

Each question has **FOUR** options (A), (B), (C) and (D). **ONLY ONE** of these four options is correct.

For each question, darken the bubble(s) corresponding to the correct option in the ORS.

For each question, marks will be awarded in one of the following categories:

**Full Marks** : +3 If only the bubble corresponding to the correct option is darkened

**Zero Marks** : 0 In all other cases

**PARAGRAPH 1**

Upon heating  $\text{KClO}_3$  in the presence of catalytic amount of  $\text{MnO}_2$ , a gas **W** is formed. Excess amount of **W** reacts with white phosphorus to give **X**. The reaction of **X** with pure  $\text{HNO}_3$  gives **Y** and **Z**.

33. **W** and **X** are, respectively

- (A)  $\text{O}_3$  and  $\text{P}_4\text{O}_6$  (B)  $\text{O}_2$  and  $\text{P}_4\text{O}_6$   
(C)  $\text{O}_2$  and  $\text{P}_4\text{O}_{10}$  (D)  $\text{O}_3$  and  $\text{P}_4\text{O}_{10}$

**Answer (C)**

34. **Y** and **Z** are, respectively

- (A)  $\text{N}_2\text{O}_5$  and  $\text{HPO}_3$  (B)  $\text{N}_2\text{O}_3$  and  $\text{H}_3\text{PO}_4$   
(C)  $\text{N}_2\text{O}_4$  and  $\text{HPO}_3$  (D)  $\text{N}_2\text{O}_4$  and  $\text{H}_3\text{PO}_3$

**Answer (A)**

**Solutions of Q.No (33) & (34)**

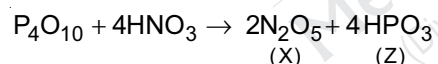
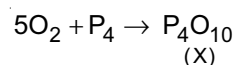
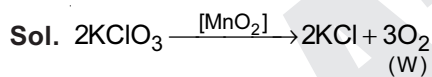

**PARAGRAPH 2**

The reaction of compound **P** with  $\text{CH}_3\text{MgBr}$  (excess) in  $(\text{C}_2\text{H}_5)_2\text{O}$  followed by addition of  $\text{H}_2\text{O}$  gives **Q**. The compound **Q** on treatment with  $\text{H}_2\text{SO}_4$  at  $0^\circ\text{C}$  gives **R**. The reaction of **R** with  $\text{CH}_3\text{COCl}$  in the presence of anhydrous  $\text{AlCl}_3$  in  $\text{CH}_2\text{Cl}_2$  followed by treatment with  $\text{H}_2\text{O}$  produces compound **S**. [Et in compound **P** is ethyl group]

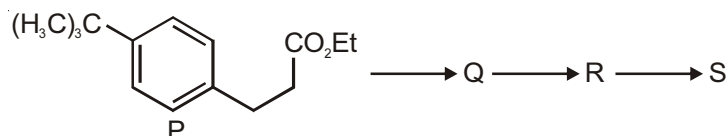

35. The reactions, **Q** to **R** and **R** to **S**, are

- (A) Dehydration and Friedel-Crafts acylation  
(B) Friedel-Crafts alkylation, dehydration and Friedel-Crafts acylation  
(C) Friedel-Crafts alkylation and Friedel-Crafts acylation  
(D) Aromatic sulfonation and Friedel-Crafts acylation

**Answer (B)**

36. The product **S** is

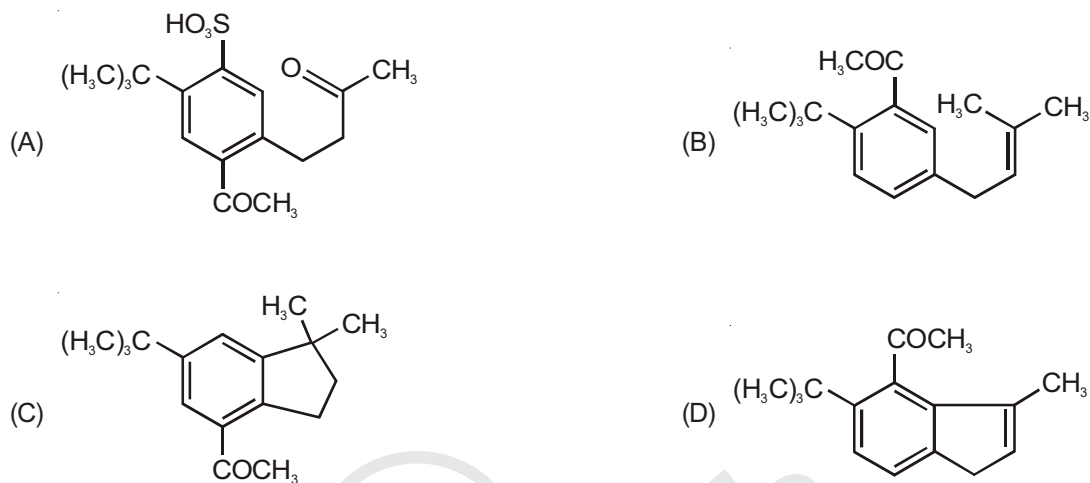

**Answer (C)**

**Solutions of Q. 35 and 36**

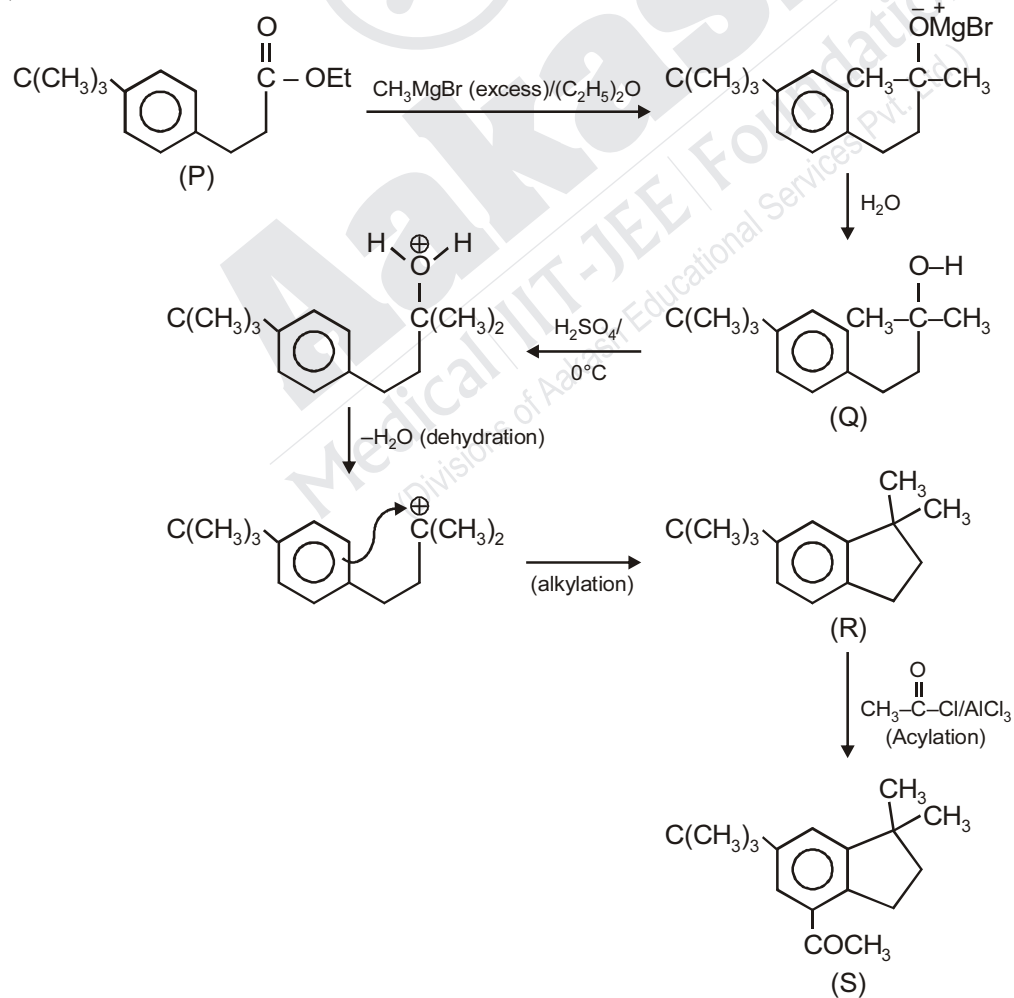

**END OF CHEMISTRY**

## MATHEMATICS

### SECTION - 1 (Maximum Marks : 21)

This section contains **SEVEN** questions.

Each question has **FOUR** options (A), (B), (C) and (D). **ONLY ONE** of these four options is correct.

For each question, darken the bubble corresponding to the correct option in the ORS.

For each question, marks will be awarded in one of the following categories:

**Full Marks** : +3 If only the bubble corresponding to the correct option is darkened

**Zero Marks** : 0 If none of the bubbles is darkened

**Negative Marks** : -1 In all other cases

37. Let  $S = \{1, 2, 3, \dots, 9\}$ . For  $k = 1, 2, \dots, 5$ , let  $N_k$  be the number of subsets of  $S$ , each containing five elements out of which exactly  $k$  are odd. Then  $N_1 + N_2 + N_3 + N_4 + N_5 =$

- (A) 125
- (B) 210
- (C) 252
- (D) 126

**Answer (D)**

**Sol.** Required number of subsets

$$\begin{aligned} &= {}^5C_1 \times {}^4C_4 + {}^5C_2 \times {}^4C_3 + {}^5C_3 \times {}^4C_2 + {}^5C_4 \times {}^4C_1 + {}^5C_5 \times {}^4C_0 \\ &= 5 + 40 + 60 + 20 + 1 \\ &= 126 \end{aligned}$$

**Alternate method**

$$\begin{aligned} &\text{Coefficient of } x^5 \text{ in } (1+x)^5(1+x)^4 \\ &= {}^9C_5 \\ &= 126 \end{aligned}$$

38. The equation of the plane passing through the point  $(1, 1, 1)$  and perpendicular to the planes  $2x + y - 2z = 5$  and  $3x - 6y - 2z = 7$ , is

- (A)  $-14x + 2y + 15z = 3$
- (B)  $14x - 2y + 15z = 27$
- (C)  $14x + 2y - 15z = 1$
- (D)  $14x + 2y + 15z = 31$

**Answer (D)**

**Sol.** Required equation of plane is

$$\begin{vmatrix} x-1 & y-1 & z-1 \\ 2 & 1 & -2 \\ 3 & -6 & -2 \end{vmatrix} = 0$$

$$\Rightarrow -14(x-1) - 2(y-1) + (-15)(z-1) = 0$$

$$\Rightarrow \boxed{14x + 2y + 15z = 31}$$

39. Let  $O$  be the origin and let  $PQR$  be an arbitrary triangle. The point  $S$  is such that

$$\overrightarrow{OP} \cdot \overrightarrow{OQ} + \overrightarrow{OR} \cdot \overrightarrow{OS} = \overrightarrow{OR} \cdot \overrightarrow{OP} + \overrightarrow{OQ} \cdot \overrightarrow{OS} = \overrightarrow{OQ} \cdot \overrightarrow{OR} + \overrightarrow{OP} \cdot \overrightarrow{OS}$$

Then the triangle  $PQR$  has  $S$  as its

- (A) Incentre
- (B) Circumcentre
- (C) Orthocenter
- (D) Centroid

**Answer (C)**

**Sol.**  $\overrightarrow{OP} \cdot \overrightarrow{OQ} + \overrightarrow{OR} \cdot \overrightarrow{OS} = \overrightarrow{OR} \cdot \overrightarrow{OP} + \overrightarrow{OQ} \cdot \overrightarrow{OS} = \overrightarrow{OQ} \cdot \overrightarrow{OR} + \overrightarrow{OP} \cdot \overrightarrow{OS}$

$$\overrightarrow{OP} \cdot \overrightarrow{OQ} + \overrightarrow{OR} \cdot \overrightarrow{OS} = \overrightarrow{OR} \cdot \overrightarrow{OP} + \overrightarrow{OQ} \cdot \overrightarrow{OS}$$

$$\Rightarrow \overrightarrow{OP} \cdot (\overrightarrow{OQ} - \overrightarrow{OR}) + \overrightarrow{OS} \cdot (\overrightarrow{OR} - \overrightarrow{OQ}) = 0$$

$$\Rightarrow \overrightarrow{RQ} \cdot (\overrightarrow{OP} - \overrightarrow{OS}) = \vec{0}$$

$$\Rightarrow \overrightarrow{RQ} \cdot \overrightarrow{SP} = \vec{0}$$

$$\Rightarrow \overrightarrow{RQ} \perp \overrightarrow{SP}$$

and similarly from  $\overrightarrow{OR} \cdot \overrightarrow{OP} + \overrightarrow{OQ} \cdot \overrightarrow{OS} = \overrightarrow{OQ} \cdot \overrightarrow{OR} + \overrightarrow{OP} \cdot \overrightarrow{OS}$

$$\overrightarrow{SR} \perp \overrightarrow{PQ}$$

$\therefore S$  is the orthocentre.

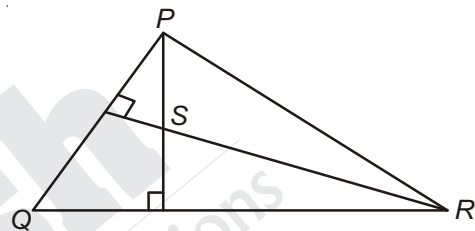

40. How many  $3 \times 3$  matrices  $M$  with entries from  $\{0, 1, 2\}$  are there, for which the sum of the diagonal entries of  $M^T M$  is 5?

- (A) 162
- (B) 135
- (C) 126
- (D) 198

**Answer (D)**

**Sol.** Let  $M = \begin{bmatrix} a_1 & b_1 & c_1 \\ a_2 & b_2 & c_2 \\ a_3 & b_3 & c_3 \end{bmatrix}$ ,  $M^T = \begin{bmatrix} a_1 & a_2 & a_3 \\ b_1 & b_2 & b_3 \\ c_1 & c_2 & c_3 \end{bmatrix}$

$$\text{Sum of diagonal entries} = \sum_{i=1}^3 (a_i^2 + b_i^2 + c_i^2) = 5$$

$\therefore$  Possible cases are (one 2, one 1 and seven zeros) or (five 1's and four 0's)

$$= \frac{9!}{7!} + \frac{9!}{5!4!} = 72 + 126 = 198$$

41. Three randomly chosen non-negative integers  $x$ ,  $y$  and  $z$  are found to satisfy the equation  $x + y + z = 10$ . Then the probability that  $z$  is even, is

- (A)  $\frac{6}{11}$
- (B)  $\frac{36}{55}$
- (C)  $\frac{1}{2}$
- (D)  $\frac{5}{11}$

**Answer (A)**

**Sol.**  $x + y + z = 10$

$$n(s) = {}^{10+3-1}C_{3-1} = {}^{12}C_2 = \frac{12 \times 11}{2} = 66$$

Let  $z = 2n$ , where  $n = 0, 1, 2, 3, 4, 5$

$$x + y + 2n = 10$$

$$x + y = 10 - 2n$$

$$\text{Total such solution} = \sum_{n=0}^5 (11 - 2n) = 36$$

$$P(E) = \frac{36}{66} = \frac{6}{11}$$

42. If  $f : \mathbb{R} \rightarrow \mathbb{R}$  is a twice differentiable function such that  $f''(x) > 0$  for all  $x \in \mathbb{R}$ , and  $f\left(\frac{1}{2}\right) = \frac{1}{2}, f(1) = 1$ , then

- (A)  $\frac{1}{2} < f'(1) \leq 1$
- (B)  $0 < f'(1) \leq \frac{1}{2}$
- (C)  $f'(1) \leq 0$
- (D)  $f'(1) > 1$

**Answer (D)**

**Sol.**  $f''(x) > 0$ ,  $f\left(\frac{1}{2}\right) = \frac{1}{2}$  and  $f(1) = 1$

$f'(x)$  is always increasing

$$f'(1) > \frac{f(1) - f\left(\frac{1}{2}\right)}{1 - \frac{1}{2}}$$

$$f'(1) > 1$$

Slope of tangent at  $B >$  Slope of chord  $AB$ .

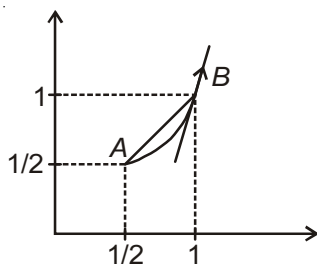

43. If  $y = y(x)$  satisfies the differential equation  $8\sqrt{x}(\sqrt{9+\sqrt{x}})dy = (\sqrt{4+\sqrt{9+\sqrt{x}}})^{-1} dx$ ,  $x > 0$  and  $y(0) = \sqrt{7}$ , then  $y(256) =$
- (A) 80  
(B) 9  
(C) 16  
(D) 3

**Answer (D)**

**Sol.** As,  $dy = \frac{dx}{8\sqrt{x}\sqrt{9+\sqrt{x}} \cdot \sqrt{4+\sqrt{9+\sqrt{x}}}}$

Integrating,

$$y = \sqrt{4 + \sqrt{9 + \sqrt{x}}} + c$$

at  $x = 0$ ,  $y = \sqrt{7} \Rightarrow c = 0$

so,  $y = \sqrt{4 + \sqrt{9 + \sqrt{x}}}$

at  $x = 256$ ,  $y = 3$

### SECTION - 2 (Maximum Marks : 28)

This section contains **SEVEN** questions.

Each question has **FOUR** options (A), (B), (C) and (D). **ONE OR MORE THAN ONE** of these four options is(are) correct. For each question, darken the bubble(s) corresponding to all the correct option(s) in the ORS.

For each question, marks will be awarded in one of the following categories:

<i>Full Marks</i>	: +4	If only the bubble(s) corresponding to all the correct option(s) is(are) darkened.
<i>Partial Marks</i>	: +1	For darkening a bubble corresponding <b>to each correct option</b> , provided NO incorrect option is darkened
<i>Zero Marks</i>	: 0	If none of the bubbles is darkened
<i>Negative Marks</i>	: -2	In all other cases

For example, if (A), (C) and (D) are all the correct options for a question, darkening all these three will get +4 marks; darkening only (A) and (D) will get +2 marks; and darkening (A) and (B) will get -2 marks, as a wrong option is also darkened.

44. If the line  $x = \alpha$  divides the area of region  $R = \{(x, y) \in \mathbb{R}^2 : x^3 \leq y \leq x, 0 \leq x \leq 1\}$  into two equal parts, then

(A)  $0 < \alpha \leq \frac{1}{2}$

(B)  $2\alpha^4 - 4\alpha^2 + 1 = 0$

(C)  $\alpha^4 + 4\alpha^2 - 1 = 0$

(D)  $\frac{1}{2} < \alpha < 1$

Answer (B, D)

Sol.  $\int_0^\alpha (x - x^3) dx = \int_\alpha^1 (x - x^3) dx$

$$\Rightarrow \left. \frac{x^2}{2} - \frac{x^4}{4} \right|_0^\alpha = \left. \frac{x^2}{2} - \frac{x^4}{4} \right|_\alpha^1$$

$$\Rightarrow \frac{\alpha^2}{2} - \frac{\alpha^4}{4} = \left( \frac{1}{2} - \frac{1}{4} \right) - \left( \frac{\alpha^2}{2} - \frac{\alpha^4}{4} \right)$$

$$\Rightarrow \frac{\alpha^4}{2} - \alpha^2 + \frac{1}{4} = 0$$

$$\Rightarrow \boxed{2\alpha^4 - 4\alpha^2 + 1 = 0}$$

Let  $f(\alpha) = 2\alpha^4 - 4\alpha^2 + 1$

$$f(0) = 1 > 0, \quad f\left(\frac{1}{2}\right) = \frac{1}{8} > 0$$

$$f(1) = -1 < 0$$

$$\therefore \alpha \in \left(\frac{1}{2}, 1\right)$$

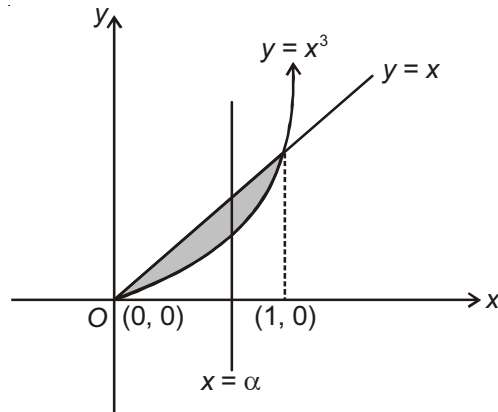

45. If  $f(x) = \begin{vmatrix} \cos(2x) & \cos(2x) & \sin(2x) \\ -\cos x & \cos x & -\sin x \\ \sin x & \sin x & \cos x \end{vmatrix}$ , then

- (A)  $f(x)$  attains its maximum at  $x = 0$
- (B)  $f(x)$  attains its minimum at  $x = 0$
- (C)  $f'(x) = 0$  at more than three points in  $(-\pi, \pi)$
- (D)  $f'(x) = 0$  at exactly three points in  $(-\pi, \pi)$

Answer (A, C)

Sol.  $C_1 \rightarrow C_1 - C_2$

$$f(x) = \begin{vmatrix} 0 & \cos 2x & \sin 2x \\ -2\cos x & \cos x & -\sin x \\ 0 & \sin x & \cos x \end{vmatrix}$$

$$\Rightarrow f(x) = 2\cos x(\cos 2x \cos x - \sin x \sin 2x)$$

$$\Rightarrow f(x) = 2\cos x \cos 3x; \quad (f(0) = 2 \text{ maximum at } x = 0)$$

$$\Rightarrow f(x) = \cos 4x + \cos 2x$$

$$f'(x) = -2\sin 2x(4\cos 2x + 1)$$

$$\Rightarrow \sin 2x = 0 \text{ or } \cos 2x = -\frac{1}{4}$$

$$2x = 0, \pi, -\pi$$

$$x = 0, \frac{\pi}{2}, -\frac{\pi}{2} \text{ and } \cos 2x = -\frac{1}{4} \text{ gives 4 solutions in } (-\pi, \pi)$$

$\therefore$  Total number of solutions = 7

46. If  $I = \sum_{k=1}^{98} \int_k^{k+1} \frac{k+1}{x(x+1)} dx$ , then

(A)  $I > \frac{49}{50}$

(B)  $I < \frac{49}{50}$

(C)  $I < \log_e 99$

(D)  $I > \log_e 99$

**Answer (A, C)**

**Sol.**  $I = \sum_{k=1}^{98} (k+1) \left( \int_k^{k+1} \frac{dx}{x(x+1)} \right)$

$$= \sum_{k=1}^{98} (k+1) \left\{ \log \left( \frac{x}{1+x} \right) \right\}_k^{k+1} = \sum_{k=1}^{98} (k+1) \left\{ \log \left( \frac{k+1}{k+2} \right) - \log \left( \frac{k}{k+1} \right) \right\}$$

$$= \sum_{k=1}^{98} \left\{ (k+1) \log \left( \frac{k+1}{k+2} \right) - k \log \left( \frac{k}{k+1} \right) \right\} + \{ \log(k+1) - \log k \}$$

$$= \left\{ 99 \log \left( \frac{99}{100} \right) - \log \left( \frac{1}{2} \right) \right\} + (\log 99 - \log 1)$$

$$= 99 \log \left( \frac{99}{100} \right) + \log 2 + \log_e (99)$$

47. Let  $f(x) = \frac{1-x(1+|1-x|)}{|1-x|} \cos \left( \frac{1}{1-x} \right)$  for  $x \neq 1$ . Then

(A)  $\lim_{x \rightarrow 1^+} f(x) = 0$

(B)  $\lim_{x \rightarrow 1^-} f(x) = 0$

(C)  $\lim_{x \rightarrow 1^+} f(x)$  does not exist

(D)  $\lim_{x \rightarrow 1^-} f(x)$  does not exist

**Answer (B, C)**

**Sol.**  $f(x) = \frac{1-x(1+|1-x|)}{|1-x|} \cos\left(\frac{1}{1-x}\right)$

$$\lim_{x \rightarrow 1^+} \frac{1-x(1+x-1)}{(x-1)} \cos\left(\frac{1}{1-x}\right)$$

$$\lim_{x \rightarrow 1^+} \frac{1-x^2}{(x-1)} \cos\left(\frac{1}{1-x}\right)$$

$$\lim_{x \rightarrow 1^+} -(1+x) \cos\left(\frac{1}{1-x}\right) = \text{a number lying between } -2 \text{ and } 2$$

Hence, limit does not exist.

$$\lim_{x \rightarrow 1^-} \frac{1-x(1+(1-x))}{(1-x)} \cos\left(\frac{1}{1-x}\right)$$

$$\lim_{x \rightarrow 1^-} \frac{1-x(2-x)}{(1-x)} \cos\left(\frac{1}{1-x}\right)$$

$$\lim_{x \rightarrow 1} (1-x) \cos\left(\frac{1}{1-x}\right) = 0$$

48. If  $f : \mathbb{R} \rightarrow \mathbb{R}$  is a differentiable function such that  $f'(x) > 2f(x)$  for all  $x \in \mathbb{R}$ , and  $f(0) = 1$ , then

- (A)  $f(x)$  is increasing in  $(0, \infty)$
- (B)  $f'(x) < e^{2x}$  in  $(0, \infty)$
- (C)  $f(x) > e^{2x}$  in  $(0, \infty)$
- (D)  $f(x)$  is decreasing in  $(0, \infty)$

**Answer (A, C)**

**Sol.**  $f'(x) - 2f(x) > 0$

$$e^{-2x} \cdot f'(x) - 2e^{-2x} \cdot f(x) > 0$$

$$\frac{d}{dx}(e^{-2x}f(x)) > 0 \Rightarrow e^{-2x} \cdot f(x) \text{ is increasing function.}$$

$$e^{-2x} \cdot f(x) > 1 \text{ for all } x \in (0, \infty)$$

$$f(x) > e^{2x}$$

$$\therefore f'(x) > 2f(x) > e^{2x} > 0$$

$\therefore f(x)$  is increasing

$$\text{Also as, } f'(x) = \frac{f(x) - f(0)}{x - 0} \Rightarrow f'(x) = \frac{f(x) - 1}{x}$$

$$\text{i.e., } f'(x) > e^{2x} \quad \forall x \in (0, 1)$$

$$< e^{2x} \quad \forall x \in (1, \infty)$$

49. If  $g(x) = \int_{\sin x}^{\sin(2x)} \sin^{-1}(t) dt$ , then

(A)  $g'\left(-\frac{\pi}{2}\right) = -2\pi$

(B)  $g'\left(-\frac{\pi}{2}\right) = 2\pi$

(C)  $g'\left(\frac{\pi}{2}\right) = 2\pi$

(D)  $g'\left(\frac{\pi}{2}\right) = -2\pi$

**Answer (No options is correct)**

**Sol.**  $g'(x) = (\sin^{-1}(\sin 2x))2\cos 2x - (\sin^{-1}(\sin x))\cos x$

$$\therefore g'\left(\frac{\pi}{2}\right) = 0, \quad g'\left(-\frac{\pi}{2}\right) = 0$$

None of the given options is correct.

50. Let  $\alpha$  and  $\beta$  be non-zero real numbers such that  $2(\cos\beta - \cos\alpha) + \cos\alpha \cos\beta = 1$ . Then which of the following is/are true?

(A)  $\tan\left(\frac{\alpha}{2}\right) + \sqrt{3}\tan\left(\frac{\beta}{2}\right) = 0$

(B)  $\sqrt{3}\tan\left(\frac{\alpha}{2}\right) - \tan\left(\frac{\beta}{2}\right) = 0$

(C)  $\tan\left(\frac{\alpha}{2}\right) - \sqrt{3}\tan\left(\frac{\beta}{2}\right) = 0$

(D)  $\sqrt{3}\tan\left(\frac{\alpha}{2}\right) + \tan\left(\frac{\beta}{2}\right) = 0$

**Answer (A, C)**

**Sol.** As  $2(\cos\beta - \cos\alpha) = 1 - \cos\alpha \cdot \cos\beta$

$$\Rightarrow \cos\alpha = \frac{2\cos\beta - 1}{2 - \cos\beta}$$

Using componendo and dividendo

$$\Rightarrow \frac{1 - \cos\alpha}{1 + \cos\alpha} = 3 \left( \frac{1 - \cos\beta}{1 + \cos\beta} \right)$$

$$\Rightarrow \tan^2 \frac{\alpha}{2} - 3 \tan^2 \frac{\beta}{2} = 0$$

So,  $\tan \frac{\alpha}{2} + \sqrt{3} \tan \frac{\beta}{2} = 0$

Or

$$\tan \frac{\alpha}{2} - \sqrt{3} \tan \frac{\beta}{2} = 0$$

**SECTION - 3 (Maximum Marks : 12)**

This section contains **TWO** Paragraphs.

Based on each paragraph, there are **TWO** questions.

Each question has **FOUR** options (A), (B), (C) and (D). **ONLY ONE** of these four options is correct.

For each question, darken the bubble(s) corresponding to the correct option in the ORS.

For each question, marks will be awarded in one of the following categories:

**Full Marks** : +3 If only the bubble corresponding to the correct option is darkened

**Zero Marks** : 0 In all other cases

**PARAGRAPH-1**

Let  $O$  be the origin, and  $\vec{OX}$ ,  $\vec{OY}$ ,  $\vec{OZ}$  be three unit vectors in the directions of the sides  $\vec{QR}$ ,  $\vec{RP}$ ,  $\vec{PQ}$ , respectively, of a triangle  $PQR$ .

51.  $|\vec{OX} \times \vec{OY}| =$

- (A)  $\sin(P + R)$
- (B)  $\sin 2R$
- (C)  $\sin(P + Q)$
- (D)  $\sin(Q + R)$

**Answer (C)**

**Sol.**  $|\vec{OX} \times \vec{OY}| = \frac{|\vec{QR} \times \vec{RP}|}{pq}$   
 $= \frac{pq \sin R}{pq}$   
 $= \sin(P + Q)$

52. If the triangle  $PQR$  varies, then the minimum value of  $\cos(P + Q) + \cos(Q + R) + \cos(R + P)$  is

- (A)  $-\frac{3}{2}$
- (B)  $\frac{3}{2}$
- (C)  $\frac{5}{3}$
- (D)  $-\frac{5}{3}$

**Answer (A)**

**Sol.**  $\cos(P + Q) + \cos(Q + R) + \cos(R + P) = -(\cos P + \cos Q + \cos R)$

Maximum value of  $\cos P + \cos Q + \cos R = \frac{3}{2}$

Hence minimum of  $-(\cos P + \cos Q + \cos R) = -\frac{3}{2}$

**PARAGRAPH-2**

Let  $p, q$  be integers and let  $\alpha, \beta$  be the roots of the equation,  $x^2 - x - 1 = 0$ , where  $\alpha \neq \beta$ . For  $n = 0, 1, 2, \dots$ , let  $a_n = p\alpha^n + q\beta^n$ .

**FACT :** If  $a$  and  $b$  are rational numbers and  $a + b\sqrt{5} = 0$ , then  $a = 0 = b$ .

53. If  $a_4 = 28$ , then  $p + 2q =$

- (A) 12
- (B) 21
- (C) 14
- (D) 7

**Answer (A)**

**Sol.**  $a_4 = 28$

$$p\left(\frac{1+\sqrt{5}}{2}\right)^4 + q\left(\frac{1-\sqrt{5}}{2}\right)^4 = 28$$

$$\Rightarrow 56(p+q) + 24\sqrt{5}(p-q) = 28 \times 16$$

$$\Rightarrow p = q = 4$$

54.  $a_{12} =$

- (A)  $a_{11} + 2a_{10}$
- (B)  $a_{11} + a_{10}$
- (C)  $a_{11} - a_{10}$
- (D)  $2a_{11} + a_{10}$

**Answer (B)**

**Sol.**  $\alpha^2 - \alpha - 1 = 0 \Rightarrow \alpha^{12} = \alpha^{11} + \alpha^{10} \quad \dots(i)$

and  $\beta^{12} = \beta^{11} + \beta^{10} \quad \dots(ii)$

Multiplying (i) by  $p$  and (ii) by  $q$  and adding,  $a_{12} = a_{11} + a_{10}$

**END OF MATHEMATICS**