



# Aakash

Medical | IIT-JEE | Foundations

(Divisions of Aakash Educational Services Pvt. Ltd.)

Regd. Office : Aakash Tower, 8, Pusa Road, New Delhi-110005

Ph.: 011-47623456 Fax : 011-47623472

Test Booklet Code

**A**

Time : 3 hrs.

## Answers & Solutions

for

### JEE (MAIN)-2018

(Physics, Chemistry and Mathematics)

M.M. : 360

#### Important Instructions :

1. The test is of **3 hours** duration.
2. The Test Booklet consists of **90** questions. The maximum marks are **360**.
3. There are **three** parts in the question paper A, B, C consisting of **Physics, Chemistry** and **Mathematics** having 30 questions in each part of equal weightage. Each question is allotted 4 (**four**) marks for each correct response.
4. *Candidates will be awarded marks as stated above in Instructions No. 3 for correct response of each question.  $\frac{1}{4}$  (one-fourth) marks of the total marks allotted to the question (i.e. 1 mark) will be deducted for indicating incorrect response of each question. No deduction from the total score will be made if no response is indicated for an item in the answer sheet.*
5. There is only one correct response for each question. Filling up more than one response in any question will be treated as wrong response and marks for wrong response will be deducted accordingly as per instruction No. 4 above.
6. For writing particulars/markings responses on **Side-1** and **Side-2** of the Answer Sheet use **only Black Ball Point Pen** provided in the examination hall.
7. No candidate is allowed to carry any textual material, printed or written, bits of papers, pager, mobile phone, any electronic device, etc. except the Admit Card inside the examination hall/room.

**PART-A : PHYSICS**

1. The density of a material in the shape of a cube is determined by measuring three sides of the cube and its mass. If the relative errors in measuring the mass and length are respectively 1.5% and 1%, the maximum error in determining the density is

- (1) 2.5%                      (2) 3.5%  
(3) 4.5%                      (4) 6%

**Answer (3)**

**Sol.**  $\rho = \frac{m}{l^3}$

$$\frac{d\rho}{\rho} = \frac{dm}{m} + 3\frac{dl}{l}$$

$$= (1.5 + 3 \times 1)$$

$$= 4.5\%$$

2. All the graphs below are intended to represent the same motion. One of them does it incorrectly. Pick it up.

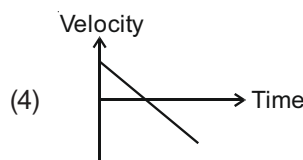
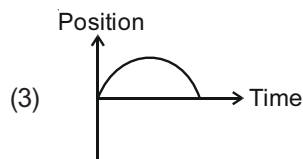
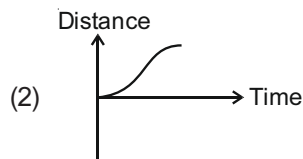
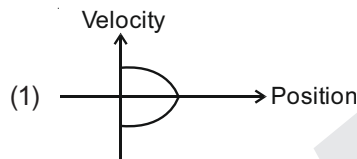

**Answer (2)**

**Sol.** Options (1), (3) and (4) correspond to uniformly accelerated motion in a straight line with positive initial velocity and constant negative acceleration, whereas option (2) does not correspond to this motion.

3. Two masses  $m_1 = 5$  kg and  $m_2 = 10$  kg, connected by an inextensible string over a frictionless pulley, are moving as shown in the figure. The coefficient of friction of horizontal surface is 0.15. The minimum weight  $m$  that should be put on top of  $m_2$  to stop the motion is

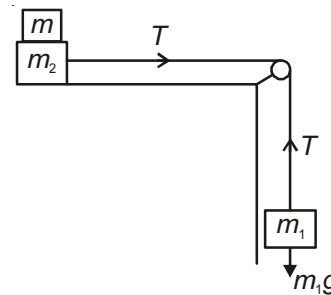

- (1) 18.3 kg  
(2) 27.3 kg  
(3) 43.3 kg  
(4) 10.3 kg

**Answer (2)**

**Sol.** To stop the moving block  $m_2$ , acceleration of  $m_2$  should be opposite to velocity of  $m_2$

$$m_1 g < \mu(m + m_2)g$$

$$\Rightarrow 5 < 0.15(10 + m_2)$$

$$\Rightarrow m_2 > 23.33 \text{ kg}$$

$\therefore$  Minimum mass = 27.3 kg (according to given options)

4. A particle is moving in a circular path of radius  $a$

under the action of an attractive potential  $U = -\frac{k}{2r^2}$ .

Its total energy is

- (1)  $-\frac{k}{4a^2}$   
(2)  $\frac{k}{2a^2}$   
(3) Zero  
(4)  $-\frac{3}{2} \frac{k}{a^2}$

**Answer (3)**

**Sol.**  $F = \frac{-dU}{dr}$        $\left[ U = -\frac{k}{2r^2} \right]$

$\frac{mv^2}{r} = \frac{k}{r^3}$       [This force provides necessary centripetal force]

$\Rightarrow mv^2 = \frac{k}{r^2}$

$\Rightarrow K.E = \frac{k}{2r^2}$

$\Rightarrow P.E = -\frac{k}{2r^2}$

Total energy = Zero

5. In a collinear collision, a particle with an initial speed  $v_0$  strikes a stationary particle of the same mass. If the final total kinetic energy is 50% greater than the original kinetic energy, the magnitude of the relative velocity between the two particles, after collision, is

- (1)  $\frac{v_0}{4}$
- (2)  $\sqrt{2}v_0$
- (3)  $\frac{v_0}{2}$
- (4)  $\frac{v_0}{\sqrt{2}}$

**Answer (2)**

**Sol.** It is a case of superelastic collision

$mv_0 = mv_1 + mv_2$       ... (i)

$\Rightarrow v_1 + v_2 = v_0$

$\frac{1}{2}m(v_1^2 + v_2^2) = \frac{3}{2}\left(\frac{1}{2}mv_0^2\right)$

$\Rightarrow (v_1^2 + v_2^2) = \frac{3}{2}v_0^2$       ... (ii)

$\Rightarrow (v_1 + v_2)^2 = v_1^2 + v_2^2 + 2v_1v_2$

$\Rightarrow v_0^2 = \frac{3v_0^2}{2} + 2v_1v_2$

$\Rightarrow 2v_1v_2 = -\frac{v_0^2}{2}$       ... (iii)

$\therefore (v_1 - v_2)^2 = (v_1 + v_2)^2 - 4v_1v_2 = v_0^2 + v_0^2$

$\Rightarrow v_1 - v_2 = \sqrt{2}v_0$

6. Seven identical circular planar disks, each of mass  $M$  and radius  $R$  are welded symmetrically as shown. The moment of inertia of the arrangement about the axis normal to the plane and passing through the point  $P$  is

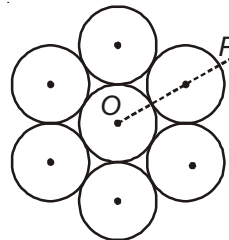

- (1)  $\frac{19}{2}MR^2$
- (2)  $\frac{55}{2}MR^2$
- (3)  $\frac{73}{2}MR^2$
- (4)  $\frac{181}{2}MR^2$

**Answer (4)**

**Sol.**  $I_0 = \frac{MR^2}{2} + 6\left(\frac{MR^2}{2} + M(2R)^2\right)$

$I_P = I_0 + 7M(3R)^2$   
 $= \frac{181}{2}MR^2$

7. From a uniform circular disc of radius  $R$  and mass  $9M$ , a small disc of radius  $\frac{R}{3}$  is removed as shown in the figure. The moment of inertia of the remaining disc about an axis perpendicular to the plane of the disc and passing through centre of disc is

- (1)  $4MR^2$
- (2)  $\frac{40}{9}MR^2$
- (3)  $10MR^2$
- (4)  $\frac{37}{9}MR^2$

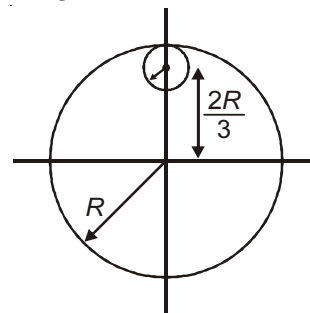

**Answer (1)**

**Sol.**  $m = \frac{(9M)}{9} = M$

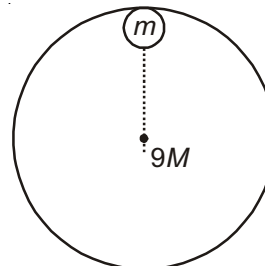

$I_1 = \frac{(9M) \times R^2}{2}$

$$I_2 = \frac{M \times \left(\frac{R}{3}\right)^2}{2} + M \times \left(\frac{2R}{3}\right)^2 = \frac{MR^2}{2}$$

$$\begin{aligned} \therefore I_{\text{req}} &= I_1 - I_2 \\ &= \frac{9}{2}MR^2 - \frac{MR^2}{2} \\ &= 4MR^2 \end{aligned}$$

8. A particle is moving with a uniform speed in a circular orbit of radius  $R$  in a central force inversely proportional to the  $n^{\text{th}}$  power of  $R$ . If the period of rotation of the particle is  $T$ , then

$$(1) T \propto R^{3/2} \text{ for any } n \quad (2) T \propto R^{\frac{n}{2}+1}$$

$$(3) T \propto R^{(n+1)/2} \quad (4) T \propto R^{n/2}$$

**Answer (3)**

**Sol.**  $m\omega^2 R = k R^{-n} = \frac{k}{R^n}$

$$\Rightarrow \frac{1}{T^2} \propto \frac{1}{R^{n+1}}$$

$$\Rightarrow T \propto R^{\left(\frac{n+1}{2}\right)}$$

9. A solid sphere of radius  $r$  made of a soft material of bulk modulus  $K$  is surrounded by a liquid in a cylindrical container. A massless piston of area of floats on the surface of the liquid, covering entire cross-section of cylindrical container. When a mass  $m$  is placed on the surface of the piston to compress the liquid, the fractional decrement in the

radius of the sphere,  $\left(\frac{dr}{r}\right)$ , is

$$(1) \frac{Ka}{mg} \quad (2) \frac{Ka}{3mg}$$

$$(3) \frac{mg}{3Ka} \quad (4) \frac{mg}{Ka}$$

**Answer (3)**

**Sol.**  $K = -V \frac{dP}{dV}$

$$\Rightarrow \frac{-dV}{V} = \frac{dP}{K} = \frac{mg}{Ka}$$

$$\Rightarrow \frac{-3dr}{r} = \frac{mg}{Ka}$$

$$\Rightarrow \frac{dr}{r} = -\frac{mg}{3Ka}$$

10. Two moles of an ideal monoatomic gas occupies a volume  $V$  at  $27^\circ\text{C}$ . The gas expands adiabatically to a volume  $2V$ . Calculate (a) the final temperature of the gas and (b) change in its internal energy.

- (1) (a) 189 K (b) 2.7 kJ  
(2) (a) 195 K (b) -2.7 kJ  
(3) (a) 189 K (b) -2.7 kJ  
(4) (a) 195 K (b) 2.7 kJ

**Answer (3)**

**Sol.**  $TV^{\gamma-1} = \text{Constant}$

$$T_f = 300 \left(\frac{V}{2V}\right)^{\frac{5}{3}-1} = 189 \text{ K}$$

$$\begin{aligned} \Delta U &= nC_v \Delta T = 2 \times \frac{3R}{2} \times [189 - 300] \\ &= -2.7 \text{ kJ} \end{aligned}$$

11. The mass of a hydrogen molecule is  $3.32 \times 10^{-27}$  kg. If  $10^{23}$  hydrogen molecules strike, per second, a fixed wall of area  $2 \text{ cm}^2$  at an angle of  $45^\circ$  to the normal, and rebound elastically with a speed of  $10^3$  m/s, then the pressure on the wall is nearly

- (1)  $2.35 \times 10^3 \text{ N/m}^2$  (2)  $4.70 \times 10^3 \text{ N/m}^2$   
(3)  $2.35 \times 10^2 \text{ N/m}^2$  (4)  $4.70 \times 10^2 \text{ N/m}^2$

**Answer (1)**

**Sol.**  $F = nmv \cos \theta \times 2$

$$P = \frac{F}{A} = \frac{2 \cdot nmv \cos \theta}{A}$$

$$= \frac{2 \times 10^{23} \times 3.32 \times 10^{-27} \times 10^3}{\sqrt{2} \times 2 \times 10^{-4}} \text{ N/m}^2$$

$$= 2.35 \times 10^3 \text{ N/m}^2$$

12. A silver atom in a solid oscillates in simple harmonic motion in some direction with a frequency of  $10^{12}$ /second. What is the force constant of the bonds connecting one atom with the other? (Mole wt. of silver = 108 and Avagadro number =  $6.02 \times 10^{23}$  gm mole $^{-1}$ )

- (1) 6.4 N/m  
(2) 7.1 N/m  
(3) 2.2 N/m  
(4) 5.5 N/m

**Answer (2)**



Sol.  $P_{av} = E_{rms} I_{rms} \cos \phi$

$$= \frac{100}{\sqrt{2}} \times \frac{20}{\sqrt{2}} \times \frac{1}{\sqrt{2}} = \frac{1000}{\sqrt{2}}$$

$$i_{wattless} = i_{rms} \sin \phi = \frac{20}{\sqrt{2}} \times \frac{1}{\sqrt{2}} = 10$$

17. Two batteries with e.m.f 12 V and 13 V are connected in parallel across a load resistor of 10 Ω. The internal resistances of the two batteries are 1 Ω and 2 Ω respectively. The voltage across the load lies between

- (1) 11.6 V and 11.7 V    (2) 11.5 V and 11.6 V  
(3) 11.4 V and 11.5 V    (4) 11.7 V and 11.8 V

**Answer (2)**

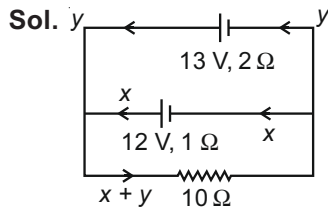

Applying KVL in loops

$$12 - x - 10(x + y) = 0$$

$$\Rightarrow 12 = 11x + 10y \quad \dots(i)$$

$$13 = 10x + 12y \quad \dots(ii)$$

Solving  $x = \frac{7}{16}A$ ,  $y = \frac{23}{32}A$

$$V = 10(x + y) = 11.56 V$$

Aliter :  $r_{eq} = \frac{2}{3}\Omega$ ,  $R = 10 \Omega$

$$\frac{E_{eq}}{r_{eq}} = \frac{E_1}{r_1} + \frac{E_2}{r_2} \Rightarrow E_{eq} = \frac{37}{3} V$$

$$V = \frac{E_{eq}}{R + r_{eq}} R = 11.56 V$$

18. An electron, a proton and an alpha particle having the same kinetic energy are moving in circular orbits of radii  $r_e$ ,  $r_p$ ,  $r_\alpha$  respectively in a uniform magnetic field  $B$ . The relation between  $r_e$ ,  $r_p$ ,  $r_\alpha$  is

- (1)  $r_e > r_p = r_\alpha$                       (2)  $r_e < r_p = r_\alpha$   
(3)  $r_e < r_p < r_\alpha$                       (4)  $r_e < r_\alpha < r_p$

**Answer (2)**

Sol.  $r = \frac{\sqrt{2mk}}{qB}$

$$\frac{r_\alpha}{r_p} = \frac{\sqrt{2m_\alpha}}{q_\alpha} \times \frac{q_p}{\sqrt{2m_p}} \quad \left[ \begin{array}{l} m_\alpha = 4m_p \\ q_\alpha = 2q_p \end{array} \right]$$

$$= 1$$

Mass of electron is least and charge  $q_e = e$

So,  $r_e < r_p = r_\alpha$

19. The dipole moment of a circular loop carrying a current  $I$ , is  $m$  and the magnetic field at the centre of the loop is  $B_1$ . When the dipole moment is doubled by keeping the current constant, the magnetic field at the centre of the loop is  $B_2$ . The

ratio  $\frac{B_1}{B_2}$  is

- (1) 2    (2)  $\sqrt{3}$   
(3)  $\sqrt{2}$                                         (4)  $\frac{1}{\sqrt{2}}$

**Answer (3)**

Sol.  $m = I(\pi R^2)$ ,  $m' = 2m = I \times (\pi\sqrt{2}R)^2$

$$\therefore R' = \sqrt{2}R$$

$$B_1 = \frac{\mu_0 I}{2R}$$

$$B_2 = \frac{\mu_0 I}{2 \times (\sqrt{2}R)}$$

$$\therefore \frac{B_1}{B_2} = \sqrt{2}$$

20. For an RLC circuit driven with voltage of amplitude  $v_m$

and frequency  $\omega_0 = \frac{1}{\sqrt{LC}}$  the current exhibits resonance. The quality factor,  $Q$  is given by

- (1)  $\frac{\omega_0 L}{R}$                                       (2)  $\frac{\omega_0 R}{L}$   
(3)  $\frac{R}{(\omega_0 C)}$                                 (4)  $\frac{CR}{\omega_0}$

**Answer (1)**

Sol. Quality factor,  $Q = \frac{\omega_0}{(2\Delta\omega)}$

$$Q = \frac{\omega_0 L}{R}$$

21. An EM wave from air enters a medium. The electric fields are  $\vec{E}_1 = E_{01} \hat{x} \cos \left[ 2\pi v \left( \frac{z}{c} - t \right) \right]$  in air and  $\vec{E}_2 = E_{02} \hat{x} \cos [k(2z - ct)]$  in medium, where the wave number  $k$  and frequency  $v$  refer to their values in air. The medium is non-magnetic. If  $\epsilon_{r1}$  and  $\epsilon_{r2}$  refer to relative permittivities of air and medium respectively, which of the following options is correct?

- (1)  $\frac{\epsilon_{r1}}{\epsilon_{r2}} = 4$                       (2)  $\frac{\epsilon_{r1}}{\epsilon_{r2}} = 2$   
 (3)  $\frac{\epsilon_{r1}}{\epsilon_{r2}} = \frac{1}{4}$                       (4)  $\frac{\epsilon_{r1}}{\epsilon_{r2}} = \frac{1}{2}$

**Answer (3)**

**Sol.**  $\vec{E}_1 = E_{01} \hat{x} \cos \left[ 2\pi v \left( \frac{z}{c} - t \right) \right]$                       air

$\vec{E}_2 = E_{02} \hat{x} \cos [k(2z - ct)]$                       medium

During refraction, frequency remains unchanged, whereas wavelength gets changed.

$\therefore k' = 2k$                       (From equations)

$\Rightarrow \frac{2\pi}{\lambda'} = 2 \left( \frac{2\pi}{\lambda_0} \right)$

$\Rightarrow \lambda' = \frac{\lambda_0}{2}$

$\Rightarrow v = \frac{c}{2}$

$\Rightarrow \frac{1}{\sqrt{\mu_0 \epsilon_2}} = \frac{1}{2} \times \frac{1}{\sqrt{\mu_0 \epsilon_1}}$

$\Rightarrow \frac{\epsilon_1}{\epsilon_2} = \frac{1}{4}$

22. Unpolarized light of intensity  $I$  passes through an ideal polarizer  $A$ . Another identical polarizer  $B$  is placed behind  $A$ . The intensity of light beyond  $B$  is found to be  $\frac{I}{2}$ . Now another identical polarizer  $C$  is placed between  $A$  and  $B$ . The intensity beyond  $B$  is now found to be  $\frac{I}{8}$ . The angle between polarizer  $A$  and  $C$  is

- (1)  $0^\circ$                                       (2)  $30^\circ$   
 (3)  $45^\circ$                                       (4)  $60^\circ$

**Answer (3)**

**Sol.** Polaroids  $A$  and  $B$  are oriented with parallel pass axis

Let polaroid  $C$  is at angle  $\theta$  with  $A$  then it makes  $\theta$  with  $B$  also.

$\therefore \frac{I}{8} = \left( \frac{I}{2} \times \cos^2 \theta \right) \times \cos^2 \theta$

$\Rightarrow \cos^2 \theta = \frac{1}{2}$

$\Rightarrow \theta = 45^\circ$

23. The angular width of the central maximum in a single slit diffraction pattern is  $60^\circ$ . The width of the slit is  $1 \mu\text{m}$ . The slit is illuminated by monochromatic plane waves. If another slit of same width is made near it, Young's fringes can be observed on a screen placed at a distance  $50 \text{ cm}$  from the slits. If the observed fringe width is  $1 \text{ cm}$ , what is slit separation distance?

(i.e. distance between the centres of each slit.)

- (1)  $25 \mu\text{m}$   
 (2)  $50 \mu\text{m}$   
 (3)  $75 \mu\text{m}$   
 (4)  $100 \mu\text{m}$

**Answer (1)**

**Sol.**  $d \sin \theta = \lambda$

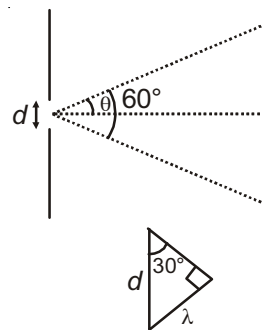

$\lambda = \frac{d}{2}$                        $[d = 1 \times 10^{-6} \text{ m}]$

$\Rightarrow \lambda = 5000 \text{ \AA}$

Fringe width,  $B = \frac{\lambda D}{d'}$  ( $d'$  is slit separation)

$10^{-2} = \frac{5000 \times 10^{-10} \times 0.5}{d'}$

$\Rightarrow d' = 25 \times 10^{-6} \text{ m} = 25 \mu\text{m}$

24. An electron from various excited states of hydrogen atom emit radiation to come to the ground state. Let  $\lambda_n, \lambda_g$  be the de Broglie wavelength of the electron in the  $n^{\text{th}}$  state and the ground state respectively. Let  $\Lambda_n$  be the wavelength of the emitted photon in the transition from the  $n^{\text{th}}$  state to the ground state. For large  $n$ , ( $A, B$  are constants)

$$(1) \Lambda_n \approx A + \frac{B}{\lambda_n^2}$$

$$(2) \Lambda_n \approx A + B\lambda_n$$

$$(3) \Lambda_n^2 \approx A + B\lambda_n^2$$

$$(4) \Lambda_n^2 \approx \lambda$$

**Answer (1)**

**Sol.**  $P_n = \frac{h}{\lambda_n}, P_g = \frac{h}{\lambda_g}$

$$k = \frac{P^2}{2m} = \frac{h^2}{2m\lambda^2}, E = -k = -\frac{h^2}{2m\lambda^2}$$

$$E_n = -\frac{h^2}{2m\lambda_n^2}, E_g = -\frac{h^2}{2m\lambda_g^2}$$

$$E_n - E_g = \frac{h^2}{2m} \left( \frac{1}{\lambda_g^2} - \frac{1}{\lambda_n^2} \right) = \frac{hc}{\Lambda_n}$$

$$\frac{h^2}{2m} \left( \frac{\lambda_n^2 - \lambda_g^2}{\lambda_g^2 \lambda_n^2} \right) = \frac{hc}{\Lambda_n}$$

$$\Lambda_n = \frac{2mc}{h} \left( \frac{\lambda_g^2 \lambda_n^2}{\lambda_n^2 - \lambda_g^2} \right)$$

$$\Lambda_n = \frac{2mc\lambda_g^2}{h} \frac{\lambda_n^2}{\lambda_n^2 \left( 1 - \frac{\lambda_g^2}{\lambda_n^2} \right)}$$

$$= \frac{2mc\lambda_g^2}{h} \left[ 1 - \frac{\lambda_g^2}{\lambda_n^2} \right]^{-1}$$

$$= \frac{2mc\lambda_g^2}{h} \left[ 1 + \frac{\lambda_g^2}{\lambda_n^2} \right]$$

$$= \frac{2mc\lambda_g^2}{h} + \left( \frac{2mc\lambda_g^4}{h} \right) \frac{1}{\lambda_n^2}$$

$$= A + \frac{B}{\lambda_n^2}$$

$$A = \frac{2mc\lambda_g^2}{h}, B = \frac{2mc\lambda_g^4}{h}$$

25. If the series limit frequency of the Lyman series is  $\nu_L$ , then the series limit frequency of the Pfund series is

$$(1) 25 \nu_L$$

$$(2) 16 \nu_L$$

$$(3) \nu_L/16$$

$$(4) \nu_L/25$$

**Answer (4)**

**Sol.**  $h\nu_L = E \left[ \frac{1}{12} - \frac{1}{\infty} \right] = E$

$$h\nu_P = E \left[ \frac{1}{5^2} - \frac{1}{\infty} \right] = \frac{E}{25}$$

$$\Rightarrow \nu_P = \frac{\nu_L}{25}$$

26. It is found that if a neutron suffers an elastic collinear collision with deuterium at rest, fractional loss of its energy is  $p_d$ ; while for its similar collision with carbon nucleus at rest, fractional loss of energy is  $p_c$ . The values of  $p_d$  and  $p_c$  are respectively

$$(1) (.89, .28)$$

$$(2) (.28, .89)$$

$$(3) (0, 0)$$

$$(4) (0, 1)$$

**Answer (1)**

**Sol.**  $mu = mv_1 + 2m \times v_2$  ... (i)

$$u = (v_2 - v_1)$$
 ... (ii)

$$\Rightarrow v_1 = -\frac{u}{3}$$

$$\therefore \frac{\Delta E}{E} = p_d = \frac{\frac{1}{2}mu^2 - \frac{1}{2}m\left(\frac{u}{3}\right)^2}{\frac{1}{2}mu^2}$$

$$= \frac{8}{9} = 0.89$$

And  $mu = mv_1 + (12m) \times v_2 \dots(iii)$

$u = (v_2 - v_1) \dots(iv)$

$\Rightarrow v_1 = -\frac{11}{13}u$

$\therefore \frac{\Delta E}{E} = p_c = \frac{\frac{1}{2}mu^2 - \frac{1}{2}m\left(\frac{11}{13}u\right)^2}{\frac{1}{2}mu^2} = \frac{48}{169} = 0.28$

27. The reading of the ammeter for a silicon diode in the given circuit is

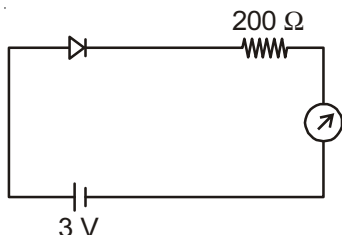

- (1) 0
- (2) 15 mA
- (3) 11.5 mA
- (4) 13.5 mA

**Answer (3)**

**Sol.**  $I = \frac{V - V_{diode}}{R}$   
 $= \left[ \frac{3 - 0.7}{200} \times 1000 \right] \text{ mA}$   
 $= 11.5 \text{ mA}$

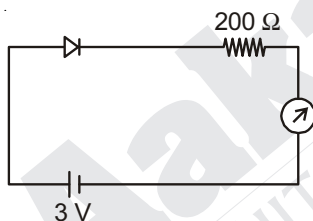

28. A telephonic communication service is working at carrier frequency of 10 GHz. Only 10% of it is utilized for transmission. How many telephonic channels can be transmitted simultaneously if each channel requires a bandwidth of 5 kHz?

- (1)  $2 \times 10^3$
- (2)  $2 \times 10^4$
- (3)  $2 \times 10^5$
- (4)  $2 \times 10^6$

**Answer (3)**

**Sol.** Frequency of carrier =  $10 \times 10^9 \text{ Hz}$   
 Available bandwidth = 10% of  $10 \times 10^9 \text{ Hz}$   
 $= 10^9 \text{ Hz}$   
 Bandwidth for each telephonic channel = 5 kHz  
 $\therefore$  Number of channels =  $\frac{10^9}{5 \times 10^3}$   
 $= 2 \times 10^5$

29. In a potentiometer experiment, it is found that no current passes through the galvanometer when the terminals of the cell are connected across 52 cm of the potentiometer wire. If the cell is shunted by a resistance of  $5 \Omega$ , a balance is found when the cell is connected across 40 cm of the wire. Find the internal resistance of the cell.

- (1)  $1 \Omega$
- (2)  $1.5 \Omega$
- (3)  $2 \Omega$
- (4)  $2.5 \Omega$

**Answer (2)**

**Sol.**  $\therefore E \propto l_1$   
 and  $E - ir \propto l_2$   
 $\therefore \frac{E}{E - ir} = \frac{l_1}{l_2}$   
 $\Rightarrow \frac{E}{E - \left(\frac{E}{r+5}\right) \times r} = \frac{52}{40}$   
 $\Rightarrow \frac{r+5}{5} = \frac{13}{10}$   
 $\Rightarrow r = 1.5 \Omega$

30. On interchanging the resistances, the balance point of a meter bridge shifts to the left by 10 cm. The resistance of their series combination is  $1 \text{ k}\Omega$ . How much was the resistance on the left slot before interchanging the resistances?

- (1)  $990 \Omega$
- (2)  $505 \Omega$
- (3)  $550 \Omega$
- (4)  $910 \Omega$

**Answer (3)**

**Sol.**  $\frac{R_1}{R_2} = \frac{l}{(100-l)}$   
 $\frac{R_2}{R_1} = \frac{(l-10)}{(110-l)}$   
 $(100-l)(110-l) = l(l-10)$   
 $11000 + l^2 - 210l = l^2 - 10l$   
 $\Rightarrow l = 55 \text{ cm}$   
 $R_1 = R_2 \left(\frac{55}{45}\right)$   
 $R_1 + R_2 = 1000 \Omega$   
 $R_1 = 550 \Omega$

**PART-B : CHEMISTRY**

31. The ratio of mass percent of C and H of an organic compound ( $C_xH_yO_z$ ) is 6 : 1. If one molecule of the above compound ( $C_xH_yO_z$ ) contains half as much oxygen as required to burn one molecule of compound  $C_xH_y$  completely to  $CO_2$  and  $H_2O$ . The empirical formula of compound  $C_xH_yO_z$  is
- (1)  $C_3H_6O_3$                       (2)  $C_2H_4O$   
(3)  $C_3H_4O_2$                       (4)  $C_2H_4O_3$

**Answer (4)**

**Sol.**

Element	Relative mass	Relative mole	Simplest whole number ratio
C	6	$\frac{6}{12} = 0.5$	1
H	1	$\frac{1}{1} = 1$	2

So, X = 1, Y = 2

Equation for combustion of  $C_xH_y$

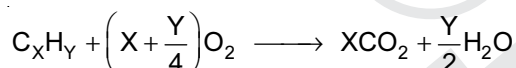

Oxygen atoms required =  $2\left(x + \frac{y}{4}\right)$

As per information,

$$2\left(x + \frac{y}{4}\right) = 2Z$$

$$\Rightarrow \left(1 + \frac{2}{4}\right) = Z$$

$$\Rightarrow Z = 1.5$$

Molecule can be written

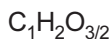
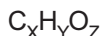

$$\Rightarrow C_2H_4O_3$$

32. Which type of 'defect' has the presence of cations in the interstitial sites?
- (1) Schottky defect  
(2) Vacancy defect  
(3) Frenkel defect  
(4) Metal deficiency defect

**Answer (3)**

**Sol.** In Frenkel defect, cation is dislocated from its normal lattice site to an interstitial site.

33. According to molecular orbital theory, which of the following will not be a viable molecule?
- (1)  $He_2^{2+}$                               (2)  $He_2^+$   
(3)  $H_2^-$                                  (4)  $H_2^{2-}$

**Answer (4)**

**Sol.**

Electronic configuration      Bond order

$$He_2^+ \quad \sigma_{1s}^2 \sigma_{1s}^* \quad \frac{2-1}{2} = 0.5$$

$$H_2^- \quad \sigma_{1s}^2 \sigma_{1s}^* \quad \frac{2-1}{2} = 0.5$$

$$H_2^{2-} \quad \sigma_{1s}^2 \sigma_{1s}^* \quad \frac{2-2}{2} = 0$$

$$He_2^{2+} \quad \sigma_{1s}^2 \quad \frac{2-0}{2} = 1$$

Molecule having zero bond order will not be a viable molecule.

34. Which of the following lines correctly show the temperature dependence of equilibrium constant K, for an exothermic reaction?

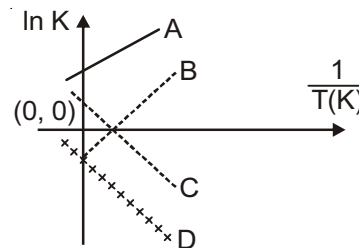

- (1) A and B                              (2) B and C  
(3) C and D                              (4) A and D

**Answer (1)**

**Sol.** Equilibrium constant  $K = \left(\frac{A_f}{A_b}\right) e^{-\frac{\Delta H^\circ}{RT}}$

$$\ln K = \ln\left(\frac{A_f}{A_b}\right) - \frac{\Delta H^\circ}{R} \left(\frac{1}{T}\right)$$

$$y = C + m x$$

Comparing with equation of straight line,

$$\text{Slope} = \frac{-\Delta H^\circ}{R}$$

Since, reaction is exothermic,  $\Delta H^\circ = -ve$ , therefore, slope = +ve.

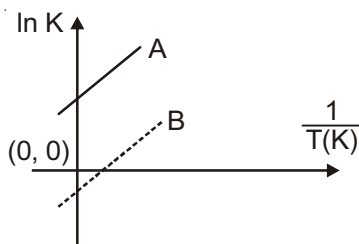

Hence, option (1) is correct.

35. The combustion of benzene (l) gives  $\text{CO}_2(\text{g})$  and  $\text{H}_2\text{O}(\text{l})$ . Given that heat of combustion of benzene at constant volume is  $-3263.9 \text{ kJ mol}^{-1}$  at  $25^\circ \text{C}$ ; heat of combustion (in  $\text{kJ mol}^{-1}$ ) of benzene at constant pressure will be

$$(R = 8.314 \text{ JK}^{-1} \text{ mol}^{-1})$$

- (1) 4152.6                      (2)  $-452.46$   
(3) 3260                        (4)  $-3267.6$

**Answer (4)**

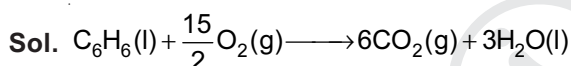

$$\Delta n_g = 6 - \frac{15}{2} = -\frac{3}{2}$$

$$\Delta H = \Delta U + \Delta n_g RT$$

$$= -3263.9 + \left(-\frac{3}{2}\right) \times 8.314 \times 298 \times 10^{-3}$$

$$= -3263.9 + (-3.71)$$

$$= -3267.6 \text{ kJ mol}^{-1}$$

36. For 1 molal aqueous solution of the following compounds, which one will show the highest freezing point?
- (1)  $[\text{Co}(\text{H}_2\text{O})_6]\text{Cl}_3$   
(2)  $[\text{Co}(\text{H}_2\text{O})_5\text{Cl}]\text{Cl}_2 \cdot \text{H}_2\text{O}$   
(3)  $[\text{Co}(\text{H}_2\text{O})_4\text{Cl}_2]\text{Cl} \cdot 2\text{H}_2\text{O}$   
(4)  $[\text{Co}(\text{H}_2\text{O})_3\text{Cl}_3] \cdot 3\text{H}_2\text{O}$

**Answer (4)**

**Sol.** The solution which shows maximum freezing point must have minimum number of solute particles.

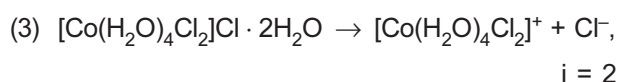
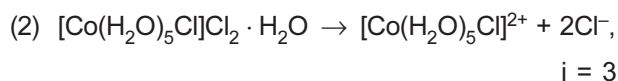

So, solution of 1 molal  $[\text{Co}(\text{H}_2\text{O})_3\text{Cl}_3] \cdot 3\text{H}_2\text{O}$  will have minimum number of particles in aqueous state.

Hence, option (4) is correct.

37. An aqueous solution contains  $0.10 \text{ M H}_2\text{S}$  and  $0.20 \text{ M HCl}$ . If the equilibrium constant for the formation of  $\text{HS}^-$  from  $\text{H}_2\text{S}$  is  $1.0 \times 10^{-7}$  and that of  $\text{S}^{2-}$  from  $\text{HS}^-$  ions is  $1.2 \times 10^{-13}$  then the concentration of  $\text{S}^{2-}$  ions in aqueous solution is

- (1)  $5 \times 10^{-8}$   
(2)  $3 \times 10^{-20}$   
(3)  $6 \times 10^{-21}$   
(4)  $5 \times 10^{-19}$

**Answer (2)**

**Sol.** In presence of external  $\text{H}^+$ ,

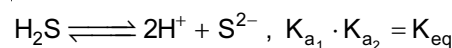

$$\therefore \frac{[\text{H}^+]^2 [\text{S}^{2-}]}{[\text{H}_2\text{S}]} = 1 \times 10^{-7} \times 1.2 \times 10^{-13}$$

$$\frac{[0.2]^2 [\text{S}^{2-}]}{[0.1]} = 1.2 \times 10^{-20}$$

$$[\text{S}^{2-}] = 3 \times 10^{-20}$$

38. An aqueous solution contains an unknown concentration of  $\text{Ba}^{2+}$ . When  $50 \text{ mL}$  of a  $1 \text{ M}$  solution of  $\text{Na}_2\text{SO}_4$  is added,  $\text{BaSO}_4$  just begins to precipitate. The final volume is  $500 \text{ mL}$ . The solubility product of  $\text{BaSO}_4$  is  $1 \times 10^{-10}$ . What is original concentration of  $\text{Ba}^{2+}$ ?

- (1)  $5 \times 10^{-9} \text{ M}$   
(2)  $2 \times 10^{-9} \text{ M}$   
(3)  $1.1 \times 10^{-9} \text{ M}$   
(4)  $1.0 \times 10^{-10} \text{ M}$

**Answer (3)**

**Sol.** Final concentration of  $[\text{SO}_4^{2-}] = \frac{[50 \times 1]}{[500]} = 0.1 \text{ M}$

$K_{\text{sp}}$  of  $\text{BaSO}_4$ ,

$$[\text{Ba}^{2+}][\text{SO}_4^{2-}] = 1 \times 10^{-10}$$

$$[\text{Ba}^{2+}][0.1] = \frac{10^{-10}}{0.1} = 10^{-9} \text{ M}$$

Concentration of  $\text{Ba}^{2+}$  in final solution =  $10^{-9} \text{ M}$

Concentration of  $\text{Ba}^{2+}$  in the original solution.

$$M_1 V_1 = M_2 V_2$$

$$M_1 (500 - 50) = 10^{-9} (500)$$

$$M_1 = 1.11 \times 10^{-9} \text{ M}$$

So, option (3) is correct.

39. At 518°C, the rate of decomposition of a sample of gaseous acetaldehyde, initially at a pressure of 363 torr, was 1.00 torr s<sup>-1</sup> when 5% had reacted and 0.5 torr s<sup>-1</sup> when 33% had reacted. The order of the reaction is

- (1) 2  
(2) 3  
(3) 1  
(4) 0

**Answer (1)**

**Sol.** Assume the order of reaction with respect to acetaldehyde is x.

**Condition-1 :**

$$\text{Rate} = k[\text{CH}_3\text{CHO}]^x$$

$$1 = k[363 \times 0.95]^x$$

$$1 = k[344.85]^x \quad \dots(i)$$

**Condition-2 :**

$$0.5 = k[363 \times 0.67]^x$$

$$0.5 = k[243.21]^x \quad \dots(ii)$$

Divide equation (i) by (ii),

$$\frac{1}{0.5} = \left(\frac{344.85}{243.21}\right)^x \Rightarrow 2 = (1.414)^x$$

$$\Rightarrow x = 2$$

40. How long (approximate) should water be electrolysed by passing through 100 amperes current so that the oxygen released can completely burn 27.66 g of diborane? (Atomic weight of B = 10.8 u)

- (1) 6.4 hours                      (2) 0.8 hours  
(3) 3.2 hours                      (4) 1.6 hours

**Answer (3)**

**Sol.**  $\text{B}_2\text{H}_6 + 3\text{O}_2 \longrightarrow \text{B}_2\text{O}_3 + 3\text{H}_2\text{O}$

27.66 g of  $\text{B}_2\text{H}_6 = 1$  mole of  $\text{B}_2\text{H}_6$  which requires three moles of oxygen ( $\text{O}_2$ ) for complete burning

$6\text{H}_2\text{O} \longrightarrow 6\text{H}_2 + 3\text{O}_2$  (On electrolysis)

Number of faradays = 12 = Amount of charge

$$12 \times 96500 = i \times t$$

$$12 \times 96500 = 100 \times t$$

$$t = \frac{12 \times 96500}{100} \text{ second}$$

$$t = \frac{12 \times 96500}{100 \times 3600} \text{ hour}$$

$$t = 3.2 \text{ hours}$$

41. The recommended concentration of fluoride ion in drinking water is up to 1 ppm as fluoride ion is required to make teeth enamel harder by converting  $[\text{3Ca}_3(\text{PO}_4)_2 \cdot \text{Ca}(\text{OH})_2]$  to

- (1)  $[\text{CaF}_2]$                       (2)  $[\text{3}(\text{CaF}_2) \cdot \text{Ca}(\text{OH})_2]$   
(3)  $[\text{3Ca}_3(\text{PO}_4)_2 \cdot \text{CaF}_2]$     (4)  $[\text{3}\{\text{Ca}(\text{OH})_2\} \cdot \text{CaF}_2]$

**Answer (3)**

**Sol.** F<sup>-</sup> ions make the teeth enamel harder by converting  $[\text{3Ca}_3(\text{PO}_4)_2 \cdot \text{Ca}(\text{OH})_2]$  to  $[\text{3Ca}_3(\text{PO}_4)_2 \cdot \text{CaF}_2]$   
Hydroxyapatite                      Fluorapatite

42. Which of the following compounds contain(s) no covalent bond(s)?

KCl, PH<sub>3</sub>, O<sub>2</sub>, B<sub>2</sub>H<sub>6</sub>, H<sub>2</sub>SO<sub>4</sub>

- (1) KCl, B<sub>2</sub>H<sub>6</sub>, PH<sub>3</sub>              (2) KCl, H<sub>2</sub>SO<sub>4</sub>  
(3) KCl                              (4) KCl, B<sub>2</sub>H<sub>6</sub>

**Answer (3)**

**Sol.** KCl – Ionic bond between K<sup>+</sup> and Cl<sup>-</sup>

PH<sub>3</sub> – Covalent bond between P and H

O<sub>2</sub> – Covalent bond between O atoms

B<sub>2</sub>H<sub>6</sub> – Covalent bond between B and H atoms

H<sub>2</sub>SO<sub>4</sub> – Covalent bond between S and O and also between O and H.

∴ Compound having no covalent bonds is KCl only.

43. Which of the following are Lewis acids?

- (1) PH<sub>3</sub> and BCl<sub>3</sub>              (2) AlCl<sub>3</sub> and SiCl<sub>4</sub>  
(3) PH<sub>3</sub> and SiCl<sub>4</sub>              (4) BCl<sub>3</sub> and AlCl<sub>3</sub>

**Answer (4)\***

**Sol.** BCl<sub>3</sub> – electron deficient, incomplete octet

AlCl<sub>3</sub> – electron deficient, incomplete octet

Ans-(4) BCl<sub>3</sub> and AlCl<sub>3</sub>

SiCl<sub>4</sub> can accept lone pair of electron in d-orbital of silicon hence it can act as Lewis acid.

\* Although the most suitable answer is (4). However, both option (4) & (2) can be considered as correct answers.

e.g. hydrolysis of SiCl<sub>4</sub>

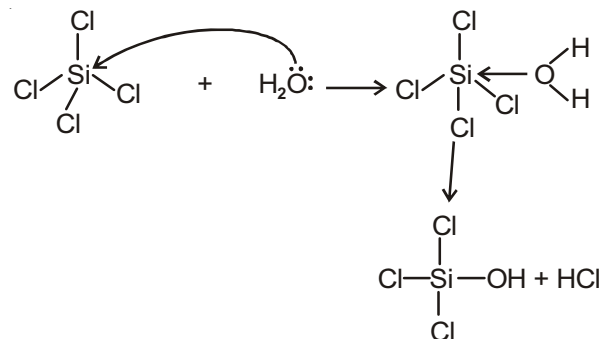

Hence option (2), AlCl<sub>3</sub> and SiCl<sub>4</sub> is also correct.

44. Total number of lone pair of electrons in  $I_3^-$  ion is

- (1) 3
- (2) 6
- (3) 9
- (4) 12

**Answer (3)**

**Sol.** Structure of  $I_3^-$

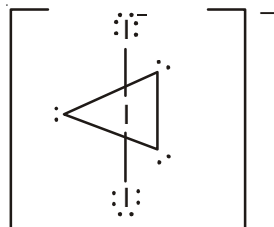

Number of lone pairs in  $I_3^-$  is 9.

45. Which of the following salts is the most basic in aqueous solution?

- (1)  $Al(CN)_3$
- (2)  $CH_3COOK$
- (3)  $FeCl_3$
- (4)  $Pb(CH_3COO)_2$

**Answer (2)**

**Sol.**  $CH_3COOK + H_2O \longrightarrow CH_3COOH + KOH$   
Basic

$FeCl_3$  – Acidic solution

$Al(CN)_3$  – Salt of weak acid and weak base

$Pb(CH_3COO)_2$  – Salt of weak acid and weak base

$CH_3COOK$  is salt of weak acid and strong base.

Hence solution of  $CH_3COOK$  is basic.

46. Hydrogen peroxide oxidises  $[Fe(CN)_6]^{4-}$  to  $[Fe(CN)_6]^{3-}$  in acidic medium but reduces  $[Fe(CN)_6]^{3-}$  to  $[Fe(CN)_6]^{4-}$  in alkaline medium. The other products formed are, respectively.

- (1)  $(H_2O + O_2)$  and  $H_2O$
- (2)  $(H_2O + O_2)$  and  $(H_2O + OH^-)$
- (3)  $H_2O$  and  $(H_2O + O_2)$
- (4)  $H_2O$  and  $(H_2O + OH^-)$

**Answer (3)**

**Sol.**  $[Fe(CN)_6]^{4-} + \frac{1}{2} H_2O_2 + H^+ \longrightarrow [Fe(CN)_6]^{3-} + H_2O$

$[Fe(CN)_6]^{3-} + \frac{1}{2} H_2O_2 + OH^- \longrightarrow [Fe(CN)_6]^{4-} + H_2O + \frac{1}{2} O_2$

47. The oxidation states of

Cr in  $[Cr(H_2O)_6]Cl_3$ ,  $[Cr(C_6H_6)_2]$ , and  $K_2[Cr(CN)_2(O)_2(O_2)(NH_3)]$  respectively are

- (1) +3, +4 and +6
- (2) +3, +2 and +4
- (3) +3, 0 and +6
- (4) +3, 0 and +4

**Answer (3)**

**Sol.**  $[Cr(H_2O)_6]Cl_3 \Rightarrow x + 0 \times 6 - 1 \times 3 = 0$   
 $\therefore x = +3$

$[Cr(C_6H_6)_2] \Rightarrow x + 2 \times 0 = 0$   
 $x = 0$

$K_2[Cr(CN)_2(O)_2(O_2)NH_3]$   
 $\Rightarrow 1 \times 2 + x - 1 \times 2 - 2 \times 2 - 2 \times 1 = 0$   
 $\Rightarrow x - 6 = 0$   
 $x = +6$

48. The compound that does not produce nitrogen gas by the thermal decomposition is

- (1)  $Ba(N_3)_2$
- (2)  $(NH_4)_2Cr_2O_7$
- (3)  $NH_4NO_2$
- (4)  $(NH_4)_2SO_4$

**Answer (4)**

**Sol.**  $(NH_4)_2Cr_2O_7 \xrightarrow{\Delta} N_2 + 4H_2O + Cr_2O_3$

$NH_4NO_2 \xrightarrow{\Delta} N_2 + 2H_2O$

$(NH_4)_2SO_4 \xrightarrow{\Delta} 2NH_3 + H_2SO_4$

$Ba(N_3)_2 \xrightarrow{\Delta} Ba + 3N_2$

Among all the given compounds, only  $(NH_4)_2SO_4$  do not form dinitrogen on heating, it produces ammonia gas.

49. When metal 'M' is treated with NaOH, a white gelatinous precipitate 'X' is obtained, which is soluble in excess of NaOH. Compound 'X' when heated strongly gives an oxide which is used in chromatography as an adsorbent. The metal 'M' is

- (1) Zn
- (2) Ca
- (3) Al
- (4) Fe

**Answer (3)**

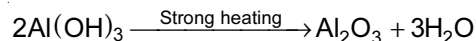
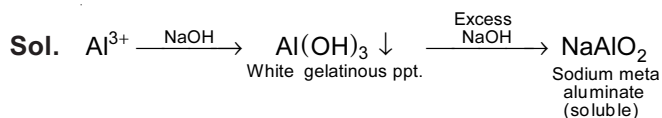

$Al_2O_3$  is used in column chromatography.

50. Consider the following reaction and statements

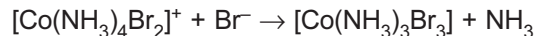

- (I) Two isomers are produced if the reactant complex ion is a *cis*-isomer
- (II) Two isomers are produced if the reactant complex ion is a *trans*-isomer.
- (III) Only one isomer is produced if the reactant complex ion is a *trans*-isomer.
- (IV) Only one isomer is produced if the reactant complex ion is a *cis*-isomer.

The correct statements are:

- (1) (I) and (II)
- (2) (I) and (III)
- (3) (III) and (IV)
- (4) (II) and (IV)

**Answer (2)**

**Sol.**

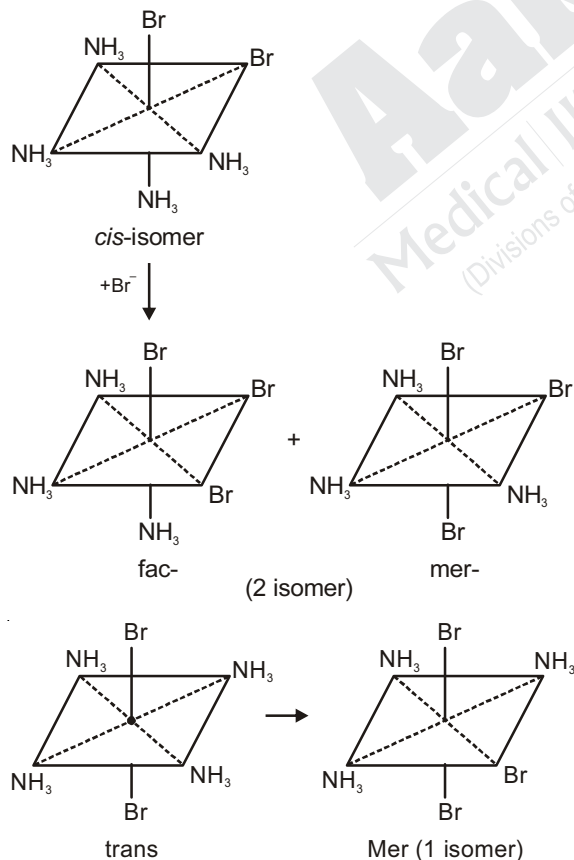

So option (2) is correct.

51. Glucose on prolonged heating with HI gives

- (1) *n*-Hexane
- (2) 1-Hexene
- (3) Hexanoic acid
- (4) 6-iodohexanal

**Answer (1)**

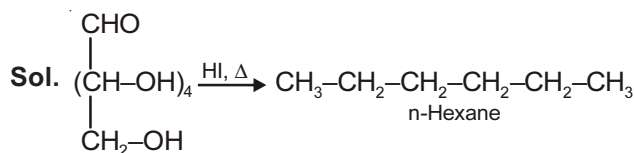

52. The *trans*-alkenes are formed by the reduction of alkynes with

- (1)  $H_2$  - Pd/C,  $BaSO_4$
- (2)  $NaBH_4$
- (3) Na/liq.  $NH_3$
- (4) Sn - HCl

**Answer (3)**

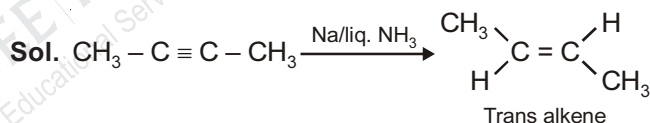

So, option (3) is correct.

53. Which of the following compounds will be suitable for Kjeldahl's method for nitrogen estimation?

- (1)
- (2)
- (3)
- (4)

**Answer (2)**

**Sol.** Kjeldahl method is not applicable for compounds containing nitrogen in nitro, and azo groups and nitrogen in ring, as N of these compounds does not change to ammonium sulphate under these conditions. Hence only aniline can be used for estimation of nitrogen by Kjeldahl's method.

54. Phenol on treatment with  $\text{CO}_2$  in the presence of  $\text{NaOH}$  followed by acidification produces compound X as the major product. X on treatment with  $(\text{CH}_3\text{CO})_2\text{O}$  in the presence of catalytic amount of  $\text{H}_2\text{SO}_4$  produces

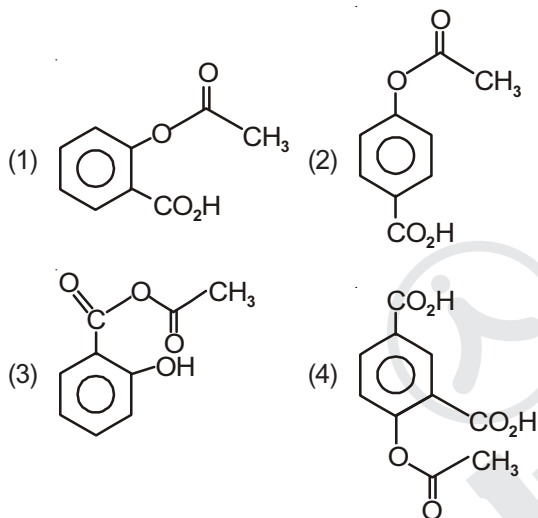

**Answer (1)**

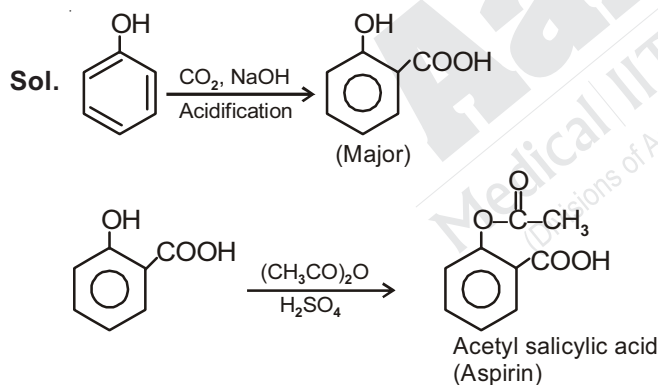

55. An alkali is titrated against an acid with methyl orange as indicator, which of the following is a correct combination?

Base	Acid	End point
(1) Weak	Strong	Colourless to pink
(2) Strong	Strong	Pinkish red to yellow
(3) Weak	Strong	Yellow to pinkish red
(4) Strong	Strong	Pink to colourless

**Answer (3)**

**Sol.** The pH range of methyl orange is

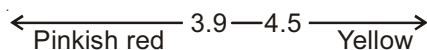

Weak base is having pH greater than 7. When methyl orange is added to weak base solution, the solution becomes yellow. This solution is titrated by strong acid and at the end point pH will be less than 3.1. Therefore solution becomes pinkish red.

56. The predominant form of histamine present in human blood is ( $\text{pK}_a$ , Histidine = 6.0)

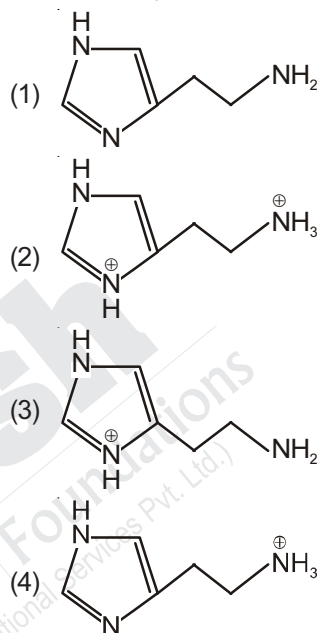

**Answer (4)**

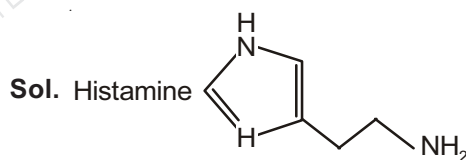

At pH (7.4) major form of histamine is protonated at primary amine.

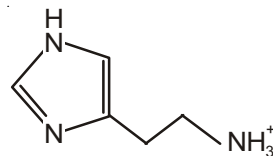

57. Phenol reacts with methyl chloroformate in the presence of  $\text{NaOH}$  to form product A. A reacts with  $\text{Br}_2$  to form product B. A and B are respectively

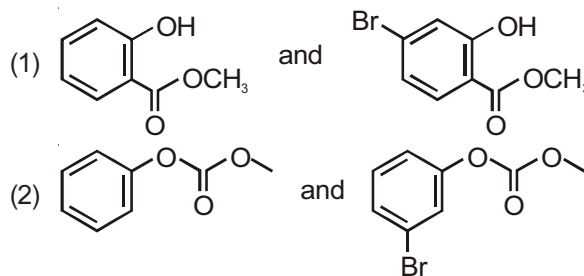

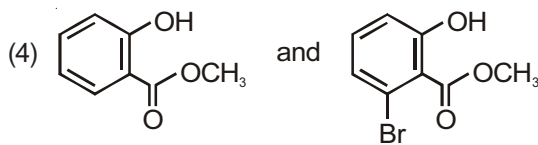
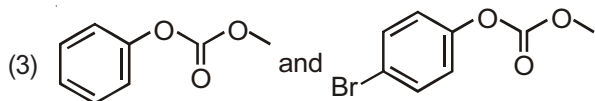

**Answer (3)**

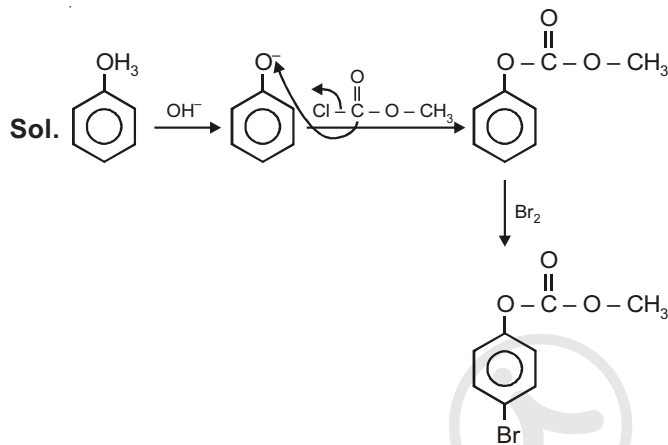

Hence, option (3) is correct.

58. The increasing order of basicity of the following compound is

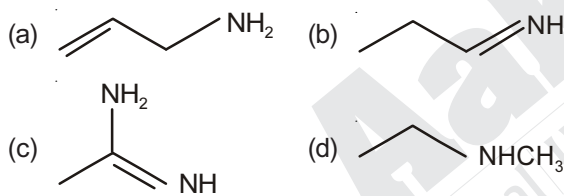

- (1) (a) < (b) < (c) < (d) (2) (b) < (a) < (c) < (d)  
(3) (b) < (a) < (d) < (c) (4) (d) < (b) < (a) < (c)

**Answer (3)**

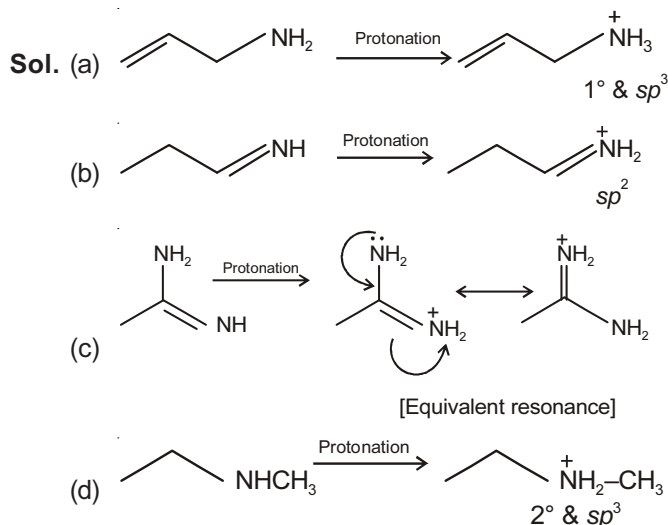

∴ Correct order of basicity : b < a < d < c.

59. The major product formed in the following reaction is

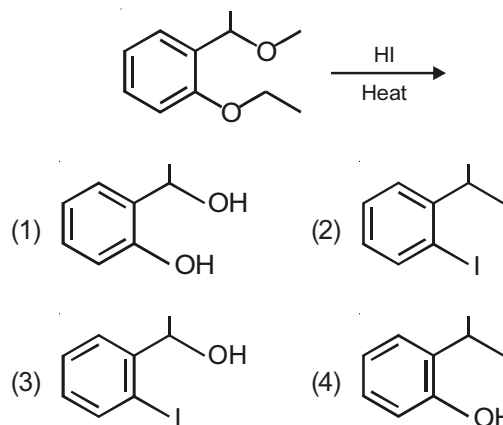

**Answer (4)**

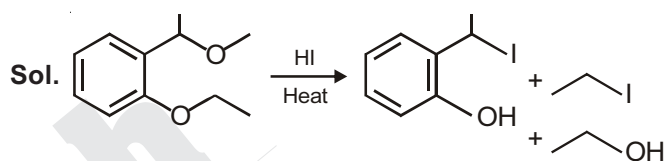

Hence, option (4) is correct.

60. The major product of the following reaction is

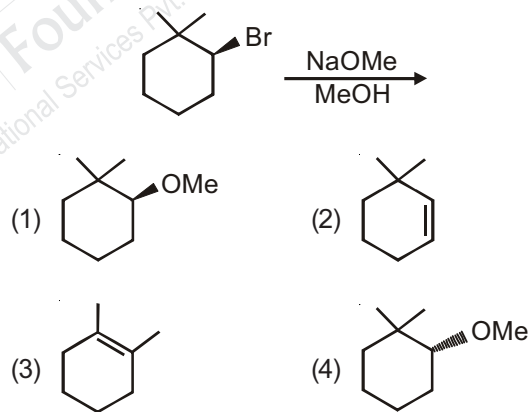

**Answer (2)**

**Sol.**  $\text{CH}_3\text{O}^-$  is a strong base and strong nucleophile, so favourable condition is  $\text{S}_\text{N}2/\text{E}2$ .

Given alkyl halide is  $2^\circ$  and  $\beta$  C's are  $4^\circ$  and  $2^\circ$ , so sufficiently hindered, therefore,  $\text{E}2$  dominates over  $\text{S}_\text{N}2$ .

Also, polarity of  $\text{CH}_3\text{OH}$  (solvent) is not as high as  $\text{H}_2\text{O}$ , so  $\text{E}1$  is also dominated by  $\text{E}2$ .

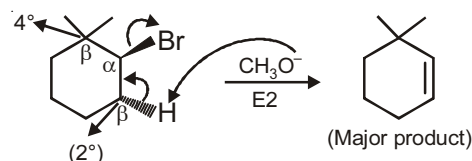

**PART-C : MATHEMATICS**

61. Two sets A and B are as under :

$$A = \{(a, b) \in R \times R : |a - 5| < 1 \text{ and } |b - 5| < 1\}$$

$$B = \{(a, b) \in R \times R : 4(a - 6)^2 + 9(b - 5)^2 \leq 36\},$$

then

- (1)  $B \subset A$
- (2)  $A \subset B$
- (3)  $A \cap B = \phi$  (an empty set)
- (4) Neither  $A \subset B$  nor  $B \subset A$

**Answer (2)**

**Sol.** As,  $|a - 5| < 1$  and  $|b - 5| < 1$

$$\Rightarrow 4 < a, b < 6 \text{ and } \frac{(a-6)^2}{9} + \frac{(b-5)^2}{4} \leq 1$$

Taking axes as a-axis and b-axis

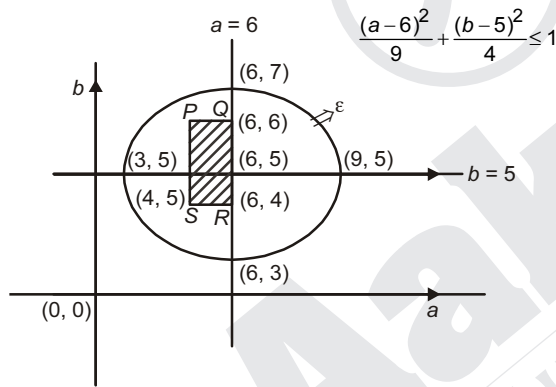

The set A represents square PQRS inside set B representing ellipse and hence  $A \subset B$ .

62. Let  $S = \{x \in R : x \geq 0 \text{ and}$

$$2|\sqrt{x} - 3| + \sqrt{x}(\sqrt{x} - 6) + 6 = 0\}$$

Then S :

- (1) Is an empty set
- (2) Contains exactly one element
- (3) Contains exactly two elements
- (4) Contains exactly four elements

**Answer (3)**

**Sol.**  $2|\sqrt{x} - 3| + \sqrt{x}(\sqrt{x} - 6) + 6 = 0$

$$2|\sqrt{x} - 3| + (\sqrt{x} - 3 + 3)(\sqrt{x} - 3 - 3) + 6 = 0$$

$$2|\sqrt{x} - 3| + (\sqrt{x} - 3)^2 - 3 = 0$$

$$(\sqrt{x} - 3)^2 + 2|\sqrt{x} - 3| - 3 = 0$$

$$(|\sqrt{x} - 3| + 3)(|\sqrt{x} - 3| - 1) = 0$$

$$\Rightarrow |\sqrt{x} - 3| = 1, |\sqrt{x} - 3| + 3 \neq 0$$

$$\Rightarrow \sqrt{x} - 3 = \pm 1$$

$$\Rightarrow \sqrt{x} = 4, 2$$

$$x = 16, 4$$

63. If  $\alpha, \beta \in C$  are the distinct roots, of the equation  $x^2 - x + 1 = 0$ , then  $\alpha^{101} + \beta^{107}$  is equal to

- (1) -1
- (2) 0
- (3) 1
- (4) 2

**Answer (3)**

**Sol.**  $x^2 - x + 1 = 0$

Roots are  $-\omega, -\omega^2$

Let  $\alpha = -\omega, \beta = -\omega^2$

$$\begin{aligned} \alpha^{101} + \beta^{107} &= (-\omega)^{101} + (-\omega^2)^{107} \\ &= -(\omega^{101} + \omega^{214}) \\ &= -(\omega^2 + \omega) \\ &= 1 \end{aligned}$$

64. If  $\begin{vmatrix} x-4 & 2x & 2x \\ 2x & x-4 & 2x \\ 2x & 2x & x-4 \end{vmatrix} = (A+Bx)(x-A)^2$ , then the

ordered pair (A, B) is equal to

- (1) (-4, -5)
- (2) (-4, 3)
- (3) (-4, 5)
- (4) (4, 5)

**Answer (3)**

**Sol.**  $\Delta = \begin{vmatrix} x-4 & 2x & 2x \\ 2x & x-4 & 2x \\ 2x & 2x & x-4 \end{vmatrix}$

$x = -4$  makes all three row identical

hence  $(x + 4)^2$  will be factor

Also,  $C_1 \rightarrow C_1 + C_2 + C_3$

$$\Delta = \begin{vmatrix} 5x-4 & 2x & 2x \\ 5x-4 & x-4 & 2x \\ 5x-4 & 2x & x-4 \end{vmatrix}$$

$\Rightarrow 5x - 4$  is a factor

$$\Delta = \lambda(5x - 4)(x + 4)^2$$

$$\therefore B = 5, A = -4$$

65. If the system of linear equations

$$x + ky + 3z = 0$$

$$3x + ky - 2z = 0$$

$$2x + 4y - 3z = 0$$

has a non-zero solution  $(x, y, z)$ , then  $\frac{xz}{y^2}$  is equal to

(1) -10

(2) 10

(3) -30

(4) 30

**Answer (2)**

**Sol.** ∵ System of equation has non-zero solution.

$$\therefore \begin{vmatrix} 1 & k & 3 \\ 3 & k & -2 \\ 2 & 4 & -3 \end{vmatrix} = 0$$

$$\Rightarrow 44 - 4k = 0$$

$$\therefore k = 11$$

Let  $z = \lambda$

$$\therefore x + 11y = -3\lambda$$

$$\text{and } 3x + 11y = 2\lambda$$

$$\therefore x = \frac{5\lambda}{2}, y = -\frac{\lambda}{2}, z = \lambda$$

$$\therefore \frac{xz}{y^2} = \frac{\frac{5\lambda}{2} \cdot \lambda}{\left(-\frac{\lambda}{2}\right)^2} = 10$$

66. From 6 different novels and 3 different dictionaries, 4 novels and 1 dictionary are to be selected and arranged in a row on a shelf so that the dictionary is always in the middle. The number of such arrangements is

(1) At least 1000

(2) Less than 500

(3) At least 500 but less than 750

(4) At least 750 but less than 1000

**Answer (1)**

**Sol.** Number of ways of selecting 4 novels from 6 novels =  ${}^6C_4$

Number of ways of selecting 1 dictionary from 3 dictionaries =  ${}^3C_1$

$$\text{Required arrangements} = {}^6C_4 \times {}^3C_1 \times 4! = 1080$$

$$\Rightarrow \text{At least 1000}$$

67. The sum of the co-efficients of all odd degree terms

in the expansion of  $(x + \sqrt{x^3 - 1})^5 + (x - \sqrt{x^3 - 1})^5$ ,

$(x > 1)$  is

(1) -1

(2) 0

(3) 1

(4) 2

**Answer (4)**

**Sol.**  $(x + \sqrt{x^3 - 1})^5 + (x - \sqrt{x^3 - 1})^5$

$$= 2[{}^5C_0 x^5 + {}^5C_2 x^3 (x^3 - 1) + {}^5C_4 x (x^3 - 1)^2]$$

$$= 2[x^5 + 10(x^6 - x^3) + 5x(x^6 - 2x^3 + 1)]$$

$$= 2[x^5 + 10x^6 - 10x^3 + 5x^7 - 10x^4 + 5x]$$

$$= 2[5x^7 + 10x^6 + x^5 - 10x^4 - 10x^3 + 5x]$$

Sum of odd degree terms coefficients

$$= 2(5 + 1 - 10 + 5)$$

$$= 2$$

68. Let  $a_1, a_2, a_3, \dots, a_{49}$  be in A.P. such that

$$\sum_{k=0}^{12} a_{4k+1} = 416 \text{ and } a_9 + a_{43} = 66.$$

If  $a_1^2 + a_2^2 + \dots + a_{17}^2 = 140m$ , then  $m$  is equal to

(1) 66

(2) 68

(3) 34

(4) 33

**Answer (3)**

**Sol.** Let  $a_1 = a$  and common difference =  $d$

$$\text{Given, } a_1 + a_5 + a_9 + \dots + a_{49} = 416$$

$$\Rightarrow a + 24d = 32 \quad \dots(i)$$

$$\text{Also, } a_9 + a_{43} = 66 \Rightarrow a + 25d = 33 \quad \dots(ii)$$

Solving (i) & (ii),

$$\text{We get } d = 1, a = 8$$

$$\text{Now, } a_1^2 + a_2^2 + \dots + a_{17}^2 = 140m$$

$$\Rightarrow 8^2 + 9^2 + \dots + 24^2 = 140m$$

$$\Rightarrow \frac{24 \times 25 \times 49}{6} - \frac{7 \times 8 \times 15}{6} = 140m$$

$$\Rightarrow \boxed{m = 34}$$



$$x - \frac{1}{x} > 0, \left(x - \frac{1}{x}\right) + \frac{2}{\left(x - \frac{1}{x}\right)} \in (2\sqrt{2}, \infty]$$

$$x - \frac{1}{x} < 0, \left(x - \frac{1}{x}\right) + \frac{2}{\left(x - \frac{1}{x}\right)} \in (-\infty, -2\sqrt{2}]$$

Local minimum is  $2\sqrt{2}$

74. The integral

$$\int \frac{\sin^2 x \cos^2 x}{(\sin^5 x + \cos^3 x \sin^2 x + \sin^3 x \cos^2 x + \cos^5 x)^2} dx$$

is equal to

$$(1) \frac{1}{3(1 + \tan^3 x)} + C \quad (2) \frac{-1}{3(1 + \tan^3 x)} + C$$

$$(3) \frac{1}{1 + \cot^3 x} + C \quad (4) \frac{-1}{1 + \cot^3 x} + C$$

(where  $C$  is a constant of integration)

**Answer (2)**

$$\text{Sol. } I = \int \frac{\sin^2 x \cdot \cos^2 x dx}{\{(\sin^2 x + \cos^2 x)(\sin^3 x + \cos^3 x)\}^2}$$

Dividing the numerator and denominator by  $\cos^6 x$

$$\Rightarrow I = \int \frac{\tan^2 x \sec^2 x dx}{(1 + \tan^3 x)^2}$$

Let,  $\tan^3 x = z$

$$\Rightarrow 3 \tan^2 x \cdot \sec^2 x dx = dz$$

$$I = \frac{1}{3} \int \frac{dz}{z^2} = \frac{-1}{3z} + C$$

$$= \frac{-1}{3(1 + \tan^3 x)} + C$$

75. Then value of  $\int_{-\frac{\pi}{2}}^{\frac{\pi}{2}} \frac{\sin^2 x}{1 + 2^x} dx$  is :

$$(1) \frac{\pi}{8} \quad (2) \frac{\pi}{2}$$

$$(3) 4\pi \quad (4) \frac{\pi}{4}$$

**Answer (4)**

$$\text{Sol. } I = \int_{-\frac{\pi}{2}}^{\frac{\pi}{2}} \frac{\sin^2 x dx}{1 + 2^x} \quad \dots (i)$$

$$\text{Also, } I = \int_{-\frac{\pi}{2}}^{\frac{\pi}{2}} \frac{2^x \sin^2 x dx}{1 + 2^x} \quad \dots (ii)$$

Adding (i) and (ii)

$$2I = \int_{-\frac{\pi}{2}}^{\frac{\pi}{2}} \sin^2 x dx$$

$$2I = 2 \int_0^{\frac{\pi}{2}} \sin^2 x dx \Rightarrow I = \int_0^{\frac{\pi}{2}} \sin^2 x dx \quad \dots (iii)$$

$$I = \int_0^{\frac{\pi}{2}} \cos^2 x dx \quad \dots (iv)$$

Adding (iii) & (iv)

$$2I = \int_0^{\frac{\pi}{2}} dx = \frac{\pi}{2} \Rightarrow I = \frac{\pi}{4}$$

76. Let  $g(x) = \cos x^2$ ,  $f(x) = \sqrt{x}$ , and  $\alpha, \beta$  ( $\alpha < \beta$ ) be the roots of the quadratic equation  $18x^2 - 9\pi x + \pi^2 = 0$ . Then the area (in sq. units) bounded by the curve  $y = (g \circ f)(x)$  and the lines  $x = \alpha$ ,  $x = \beta$  and  $y = 0$ , is

$$(1) \frac{1}{2}(\sqrt{3} - 1) \quad (2) \frac{1}{2}(\sqrt{3} + 1)$$

$$(3) \frac{1}{2}(\sqrt{3} - \sqrt{2}) \quad (4) \frac{1}{2}(\sqrt{2} - 1)$$

**Answer (1)**

$$\text{Sol. } 18x^2 - 9\pi x + \pi^2 = 0$$

$$(6x - \pi)(3x - \pi) = 0$$

$$\therefore x = \frac{\pi}{6}, \frac{\pi}{3}$$

$$\alpha = \frac{\pi}{6}, \beta = \frac{\pi}{3}$$

$$y = (g \circ f)(x) = \cos x$$

$$\text{Area} = \int_{\frac{\pi}{6}}^{\frac{\pi}{3}} \cos x \, dx = (\sin x) \Big|_{\frac{\pi}{6}}^{\frac{\pi}{3}}$$

$$= \frac{\sqrt{3}}{2} - \frac{1}{2}$$

$$= \frac{1}{2}(\sqrt{3} - 1) \text{ sq. units}$$

77. Let  $y = y(x)$  be the solution of the differential equation

$$\sin x \frac{dy}{dx} + y \cos x = 4x, \quad x \in (0, \pi). \text{ If } y\left(\frac{\pi}{2}\right) = 0,$$

then  $y\left(\frac{\pi}{6}\right)$  is equal to :

- (1)  $\frac{4}{9\sqrt{3}}\pi^2$                       (2)  $\frac{-8}{9\sqrt{3}}\pi^2$   
 (3)  $-\frac{8}{9}\pi^2$                         (4)  $-\frac{4}{9}\pi^2$

**Answer (3)**

**Sol.**  $\sin x \frac{dy}{dx} + y \cos x = 4x, \quad x \in (0, \pi)$

$$\frac{dy}{dx} + y \cot x = \frac{4x}{\sin x}$$

$$\therefore \text{I.F.} = e^{\int \cot x \, dx} = \sin x$$

$\therefore$  Solution is given by

$$y \sin x = \int \frac{4x}{\sin x} \cdot \sin x \, dx$$

$$y \cdot \sin x = 2x^2 + c$$

$$\text{when } x = \frac{\pi}{2}, y = 0 \Rightarrow c = -\frac{\pi^2}{2}$$

$$\therefore \text{Equation is : } y \sin x = 2x^2 - \frac{\pi^2}{2}$$

$$\text{when } x = \frac{\pi}{6} \text{ then } y \cdot \frac{1}{2} = 2 \cdot \frac{\pi^2}{36} - \frac{\pi^2}{2}$$

$$\therefore y = -\frac{8\pi^2}{9}$$

78. A straight line through a fixed point (2, 3) intersects the coordinate axes at distinct points P and Q. If O is the origin and the rectangle OPRQ is completed, then the locus of R is

- (1)  $3x + 2y = 6$                       (2)  $2x + 3y = xy$   
 (3)  $3x + 2y = xy$                       (4)  $3x + 2y = 6xy$

**Answer (3)**

**Sol.** Let the equation of line be  $\frac{x}{a} + \frac{y}{b} = 1$  ... (i)

(i) passes through the fixed point (2, 3)

$$\Rightarrow \frac{2}{a} + \frac{3}{b} = 1 \quad \dots \text{(ii)}$$

P(a, 0), Q(0, b), O(0, 0), Let R(h, k),

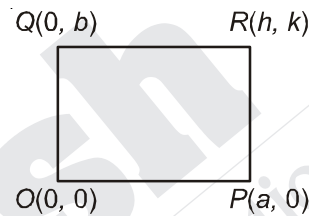

Midpoint of OR is  $\left(\frac{h}{2}, \frac{k}{2}\right)$

Midpoint of PQ is  $\left(\frac{a}{2}, \frac{b}{2}\right) \Rightarrow h = a, \quad k = b \quad \dots \text{(iii)}$

From (ii) & (iii),

$$\frac{2}{h} + \frac{3}{k} = 1 \Rightarrow \text{locus of } R(h, k)$$

$$\frac{2}{x} + \frac{3}{y} = 1 \Rightarrow 3x + 2y = xy$$

79. Let the orthocentre and centroid of a triangle be A(-3, 5) and B(3, 3) respectively. If C is the circumcentre of this triangle, then the radius of the circle having line segment AC as diameter, is

- (1)  $\sqrt{10}$                                       (2)  $2\sqrt{10}$   
 (3)  $3\sqrt{\frac{5}{2}}$                                       (4)  $\frac{3\sqrt{5}}{2}$

**Answer (3)**

**Sol.** A (-3, 5)

B (3, 3)

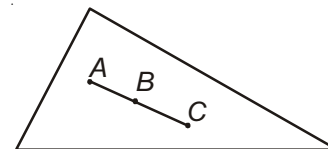



**Sol.**  $L_1$  is parallel to  $\begin{vmatrix} \hat{i} & \hat{j} & \hat{k} \\ 2 & -2 & 3 \\ 1 & -1 & 1 \end{vmatrix} = \hat{i} + \hat{j}$

$L_2$  is parallel to  $\begin{vmatrix} \hat{i} & \hat{j} & \hat{k} \\ 1 & 2 & -1 \\ 3 & -1 & 2 \end{vmatrix} = 3\hat{i} - 5\hat{j} - 7\hat{k}$

Also,  $L_2$  passes through  $\left(\frac{5}{7}, \frac{8}{7}, 0\right)$

So, required plane is  $\begin{vmatrix} x - \frac{5}{7} & y - \frac{8}{7} & z \\ 1 & 1 & 0 \\ 3 & -5 & -7 \end{vmatrix} = 0$

$\Rightarrow 7x - 7y + 8z + 3 = 0$

Now, perpendicular distance =  $\frac{3}{\sqrt{162}} = \frac{1}{3\sqrt{2}}$

84. The length of the projection of the line segment joining the points  $(5, -1, 4)$  and  $(4, -1, 3)$  on the plane,  $x + y + z = 7$  is:

(1)  $\frac{2}{\sqrt{3}}$

(2)  $\frac{2}{3}$

(3)  $\frac{1}{3}$

(4)  $\sqrt{\frac{2}{3}}$

**Answer (4)**

**Sol.**

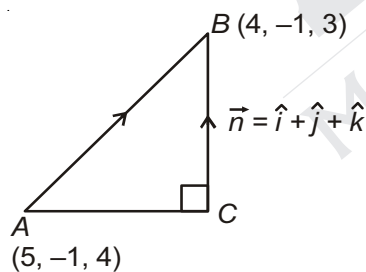

Normal to the plane  $x + y + z = 7$  is  $\vec{n} = \hat{i} + \hat{j} + \hat{k}$

$\vec{AB} = -\hat{i} - \hat{k} \Rightarrow |\vec{AB}| = AB = \sqrt{2}$

$BC = \text{Length of projection of } \vec{AB} \text{ on } \vec{n} = |\vec{AB} \cdot \hat{n}|$

$= \left| (-\hat{i} - \hat{k}) \cdot \frac{(\hat{i} + \hat{j} + \hat{k})}{\sqrt{3}} \right| = \frac{2}{\sqrt{3}}$

Length of projection of the line segment on the plane is  $AC$

$AC^2 = AB^2 - BC^2 = 2 - \frac{4}{3} = \frac{2}{3}$

$AC = \sqrt{\frac{2}{3}}$

85. Let  $\vec{u}$  be a vector coplanar with the vectors  $\vec{a} = 2\hat{i} + 3\hat{j} - \hat{k}$  and  $\vec{b} = \hat{j} + \hat{k}$ . If  $\vec{u}$  is perpendicular to  $\vec{a}$  and  $\vec{u} \cdot \vec{b} = 24$ , then  $|\vec{u}|^2$  is equal to

(1) 336

(2) 315

(3) 256

(4) 84

**Answer (1)**

**Sol.** Clearly,  $\vec{u} = \lambda(\vec{a} \times (\vec{a} \times \vec{b}))$

$\Rightarrow \vec{u} = \lambda((\vec{a} \cdot \vec{b})\vec{a} - |\vec{a}|^2 \vec{b})$

$\Rightarrow \vec{u} = \lambda(2\vec{a} - 14\vec{b}) = 2\lambda\{(2\hat{i} + 3\hat{j} - \hat{k}) - 7(\hat{j} + \hat{k})\}$

$\Rightarrow \vec{u} = 2\lambda(2\hat{i} - 4\hat{j} - 8\hat{k})$

as,  $\vec{u} \cdot \vec{b} = 24$

$\Rightarrow 4\lambda(\hat{i} - 2\hat{j} - 4\hat{k}) \cdot (\hat{j} + \hat{k}) = 24$

$\Rightarrow \lambda = -1$

So,  $\vec{u} = -4(\hat{i} - 2\hat{j} - 4\hat{k})$

$\Rightarrow |\vec{u}|^2 = 336$

86. A bag contains 4 red and 6 black balls. A ball is drawn at random from the bag, its colour is observed and this ball along with two additional balls of the same colour are returned to the bag. If now a ball is drawn at random from the bag, then the probability that this drawn ball is red, is:

(1)  $\frac{3}{10}$

(2)  $\frac{2}{5}$

(3)  $\frac{1}{5}$

(4)  $\frac{3}{4}$

**Answer (2)**

**Sol.**  $E_1$ : Event that first ball drawn is red.

$E_2$ : Event that first ball drawn is black.

$E$ : Event that second ball drawn is red.

$P(E) = P(E_1) \cdot P\left(\frac{E}{E_1}\right) + P(E_2) \cdot P\left(\frac{E}{E_2}\right)$

$= \frac{4}{10} \times \frac{6}{12} + \frac{6}{10} \times \frac{4}{12} = \frac{2}{5}$

