

DATE : 27/05/2019



Aakash

Medical | IIT-JEE | Foundations

(Divisions of Aakash Educational Services Limited)

Regd. Office : Aakash Tower, 8, Pusa Road, New Delhi-110005

Ph.: 011-47623456 Fax : 011-47623472

Time : 3 hrs.

Answers & Solutions

Max. Marks: 186

for

JEE (Advanced)-2019

PAPER - 1

PART-I : PHYSICS

SECTION - 1 (Maximum Marks : 12)

- This section contains **FOUR (04)** questions.
- Each question has **FOUR** options. **ONLY ONE** of these four options is the correct answer.
- For each question, choose the option corresponding to the correct answer.
- Answer to each question will be evaluated according to the following marking scheme:
Full Marks : +3 If **ONLY** the correct option is chosen;
Zero Marks : 0 If none of the options is chosen (i.e. the question is unanswered);
Negative Marks : -1 In all other cases.

1. A thin spherical insulating shell of radius R carries a uniformly distributed charge such that the potential at its surface is V_0 . A hole with a small area $\alpha 4\pi R^2$ ($\alpha \ll 1$) is made on the shell without affecting the rest of the shell. Which one of the following statements is correct?
- (A) The potential at the center of the shell is reduced by $2\alpha V_0$
- (B) The magnitude of electric field at the center of the shell is reduced by $\frac{\alpha V_0}{2R}$
- (C) The magnitude of electric field at a point, located on a line passing through the hole and shell's center, on a distance $2R$ from the center of the spherical shell will be reduced by $\frac{\alpha V_0}{2R}$
- (D) The ratio of the potential at the center of the shell to that of the point at $\frac{1}{2}R$ from center towards the hole will be $\frac{1-\alpha}{1-2\alpha}$

Answer (D)

Sol. For uniformly distributed charged shell surface charge density $(\sigma) = \frac{Q}{4\pi R^2}$

\therefore Charge of small area ($\alpha 4\pi R^2$) is $dq = \alpha Q$

Given that potential at surface before removing charge dq is $V_0 = \frac{Q}{4\pi\epsilon_0 R}$

$$\begin{aligned} \therefore V_{\text{center}} &= V_0 - V_{(dq)} \\ &= \frac{Q}{4\pi\epsilon_0 R} - \frac{\alpha Q}{4\pi\epsilon_0 R} = V_0(1 - \alpha) \end{aligned}$$

$$\text{Also } V_B = V_0 - \frac{\alpha Q}{4\pi\epsilon_0 \left(\frac{R}{2}\right)} = V_0(1 - 2\alpha)$$

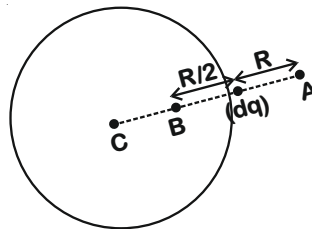

Applying principle of superposition for \vec{E}

$$E_A = \frac{kQ}{(2R)^2} - \frac{k\alpha Q}{(R)^2} = E_{\text{shell}} - \frac{\alpha V_0}{R} \Rightarrow \Delta E_A = -\frac{\alpha V_0}{R}$$

$$\text{Similarly } \Delta E_c = \frac{\alpha V_0}{R}$$

2. A current carrying wire heats a metal rod. The wire provides a constant power (P) to the rod. The metal rod is enclosed in an insulated container. It is observed that the temperature (T) in the metal rod changes with time (t) as

$$T(t) = T_0 \left(1 + \beta t^{\frac{1}{4}}\right)$$

where β is a constant with appropriate dimension while T_0 is a constant with dimension of temperature. The heat capacity of the metal is

(A) $\frac{4P(T(t) - T_0)^2}{\beta^4 T_0^3}$ (B) $\frac{4P(T(t) - T_0)^4}{\beta^4 T_0^5}$ (C) $\frac{4P(T(t) - T_0)^3}{\beta^4 T_0^4}$ (D) $\frac{4P(T(t) - T_0)}{\beta^4 T_0^2}$

Answer (C)

Sol. Rate of heat transfer through metal rod is :

$$\frac{dQ}{dt} = C \frac{dT}{dt} = P(\text{constant}) \quad \dots (1)$$

Also temperature variation is given as

$$T = T_0(1 + \beta t^{1/4}) \quad \dots (2)$$

$$\therefore \frac{dT}{dt} = \frac{T_0 \beta}{4} t^{-3/4}$$

By equation (1)

$$C = \frac{P}{\left(\frac{dT}{dt}\right)} = \frac{4P}{\beta T_0} t^{3/4}$$

Substituting the value of t from equation (2), we get

$$C = \frac{4P(T - T_0)^3}{(\beta T_0)^4}$$

3. Consider a spherical gaseous cloud of mass density $\rho(r)$ in free space where r is the radial distance from its center. The gaseous cloud is made of particles of equal mass m moving in circular orbits about the common center with the same kinetic energy K . The force acting on the particles is their mutual gravitational force. If $\rho(r)$ is constant in time, the particle number density $n(r) = \rho(r)/m$ is [G is universal gravitational constant]

- (A) $\frac{3K}{\pi r^2 m^2 G}$ (B) $\frac{K}{2\pi r^2 m^2 G}$ (C) $\frac{K}{6\pi r^2 m^2 G}$ (D) $\frac{K}{\pi r^2 m^2 G}$

Answer (B)

Sol. For a particle rotating in the circular orbit of radius r due to the gravitational attraction of inner cloud of mass M ,

$$\frac{GMm}{r^2} = \frac{mv^2}{r}$$

$$\therefore M = \frac{v^2 r}{G} = \frac{2mv^2 r}{2Gm}$$

As $K = \frac{1}{2}mv^2 = \text{constant}$, then

$$M = \frac{2Kr}{Gm} \quad \text{or} \quad dM = \frac{2Kdr}{Gm}$$

Correspondingly $dM = \rho(r) \times 4\pi r^2 dr$

$$\therefore \rho(r) \cdot 4\pi r^2 dr = \frac{2Kdr}{Gm}$$

$$\therefore \frac{\rho(r)}{m} = \frac{K}{2\pi G m^2 r^2}$$

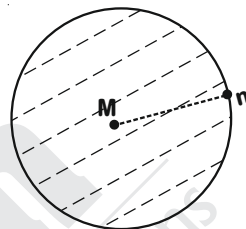

4. In a radioactive sample, ${}^{40}_{19}\text{K}$ nuclei either decay into stable ${}^{40}_{20}\text{Ca}$ nuclei with decay constant 4.5×10^{-10} per year or into stable ${}^{40}_{18}\text{Ar}$ nuclei with decay constant 0.5×10^{-10} per year. Given that in this sample all the stable ${}^{40}_{20}\text{Ca}$ and ${}^{40}_{18}\text{Ar}$ nuclei are produced by the ${}^{40}_{19}\text{K}$ nuclei only. In time $t \times 10^9$ years, if the ratio of the sum of stable ${}^{40}_{20}\text{Ca}$ and ${}^{40}_{18}\text{Ar}$ nuclei to the radioactive ${}^{40}_{19}\text{K}$ nuclei is 99, the value of t will be,

- (A) 1.15 (B) 9.2 (C) 2.3 (D) 4.6

Answer (B)

Sol. $\therefore \frac{dN}{dt} = -\lambda_1 N - \lambda_2 N$

$$\therefore \frac{dN}{dt} = -(\lambda_1 + \lambda_2) dt$$

$$\Rightarrow N = N_0 e^{-(\lambda_1 + \lambda_2)t}$$

For $N = N_0 - 99\%$ of $N_0 = 0.01 N_0$

We get

$$t = \frac{\ln 100}{\lambda_1 + \lambda_2} = \frac{2.3 \times 2}{5 \times 10^{-10}}$$

$$t = 9.2 \times 10^9 \text{ year}$$

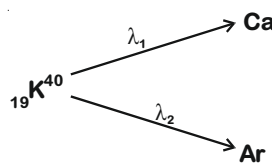

SECTION - 2 (Maximum Marks : 32)

- This section contains **EIGHT (08)** questions.
- Each question has **FOUR** options. **ONE OR MORE THAN ONE** of these four option(s) is(are) correct answer(s).
- For each question, choose the option(s) corresponding to (all) the correct answer(s).
- Answer to each question will be evaluated according to the following marking scheme:

Full Marks	: +4	If only (all) the correct option(s) is(are) chosen;
Partial Marks	: +3	If all the four options are correct but ONLY three options are chosen;
Partial Marks	: +2	If three or more options are correct but ONLY two options are chosen, and both of which are correct;
Partial Marks	: +1	If two or more options are correct but ONLY one option is chosen and it is a correct option;
Zero Marks	: 0	If none of the options is chosen (i.e. the question is unanswered);
Negative Marks	: -1	In all other cases.
- For example : in a question, if (A), (B) and (D) are the **ONLY** three options corresponding to correct answers, then
 - choosing **ONLY** (A), (B) and (D) will get +4 marks;
 - choosing **ONLY** (A) and (B) will get +2 marks;
 - choosing **ONLY** (A) and (D) will get +2 marks;
 - choosing **ONLY** (B) and (D) will get +2 marks;
 - choosing **ONLY** (A) will get +1 mark;
 - choosing **ONLY** (B) will get +1 mark;
 - choosing **ONLY** (D) will get +1 mark;
 - choosing no option (i.e., the question is unanswered) will get 0 marks; and
 - choosing any other combination of options will get -1 mark.

1. A conducting wire of parabolic shape, initially $y = x^2$, is moving with velocity $\vec{V} = V_0 \hat{i}$ in a non-uniform magnetic field $\vec{B} = B_0 \left(1 + \left(\frac{y}{L} \right)^\beta \right) \hat{k}$, as shown in figure. If V_0 , B_0 , L and β are positive constants and $\Delta\phi$ is the potential difference developed between the ends of the wire, then the correct statement(s) is/are:

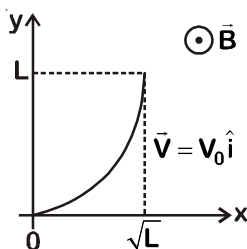

- (A) $|\Delta\phi| = \frac{1}{2} B_0 V_0 L$ for $\beta = 0$
- (B) $|\Delta\phi|$ remains the same if the parabolic wire is replaced by a straight wire, $y = x$ initially, of length $\sqrt{2} L$
- (C) $|\Delta\phi|$ is proportional to the length of the wire projected on the y-axis
- (D) $|\Delta\phi| = \frac{4}{3} B_0 V_0 L$ for $\beta = 2$

Answer (B, C, D)

Sol. $y = x^2$, $\mathbf{V} = V_0 \hat{i}$, $\mathbf{B} = B_0 \left(1 + \left(\frac{y}{L} \right)^\beta \right) \hat{k}$

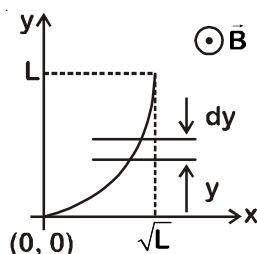

end points are $(0, 0)$ and (\sqrt{L}, L)

Let at distance 'y' small length in y direction be dy

$\therefore d\varepsilon = V_0 B dy$

$\therefore d\varepsilon = V_0 B_0 \left(1 + \left(\frac{y}{L} \right)^\beta \right) dy = V_0 B_0 \left[\int_0^L y + \frac{y^{\beta+1}}{(\beta+1)L^\beta} \right]_0^L$

$\varepsilon = V_0 B_0 \left[L + \frac{L^{\beta+1}}{(\beta+1)L^\beta} \right] \Rightarrow \varepsilon = V_0 B_0 L \left(\frac{\beta+2}{\beta+1} \right)$

If $\beta = 2$ then $\varepsilon = \frac{4}{3} V_0 B_0 L$

2. A cylindrical capillary tube of 0.2 mm radius is made by joining two capillaries T1 and T2 of different materials having water contact angles of 0° and 60° , respectively. The capillary tube is dipped vertically in water in two different configurations, case I and II as shown in figure. Which of the following option(s) is (are) correct?

[Surface tension of water = 0.075 N/m, density of water = 1000 kg/m³, take $g = 10 \text{ m/s}^2$]

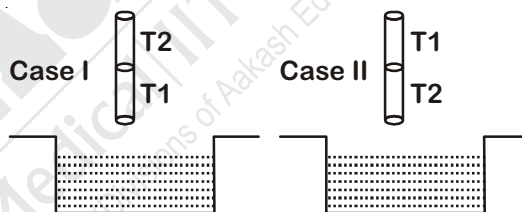

- (A) For case II, if the capillary joint is 5 cm above the water surface, the height of water column raised in the tube will be 3.75 cm. (Neglect the weight of the water in the meniscus)
- (B) For case I, if the joint is kept at 8 cm above the water surface, the height of water column in the tube will be 7.5 cm. (Neglect the weight of the water in the meniscus)
- (C) For case, I if the capillary joint is 5 cm above the water surface, the height of water column raised in the tube will be more than 8.75 cm. (Neglect the weight of the water in the meniscus)
- (D) The correction in the height of water column raised in the tube, due to weight of water contained in the meniscus, will be different for both cases.

Answer (A, B, D)

Sol. For A : $h = \frac{2T \cos 60^\circ}{\rho g r} = \frac{2 \times 0.075 \times 1}{10^3 \times 10 \times 2 \times 10^{-4} \times 2} \times 100 \text{ cm} = 3.75 \text{ cm}$

\Rightarrow Option A is correct

For B : $h = \frac{2T \cos 0}{\rho g r} = 7.5 \text{ cm}$

\Rightarrow Option B is correct

For C : Angle of contact will adjust to make $h = 5 \text{ cm}$

For D : The shape of meniscus is different in the two cases

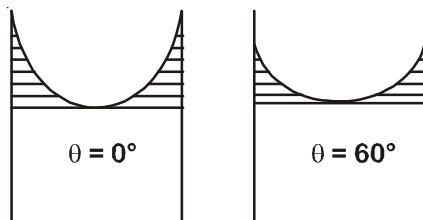

⇒ Correction is different

3. In the circuit shown, initially there is no charge on capacitors and keys S_1 and S_2 are open. The values of the capacitors are $C_1 = 10 \mu\text{F}$, $C_2 = 30 \mu\text{F}$ and $C_3 = C_4 = 80 \mu\text{F}$.

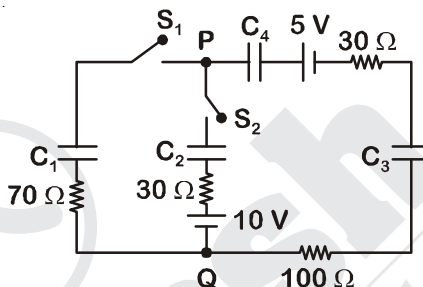

Which of the statement(s) is/are correct?

- (A) If key S_1 is kept closed for long time such that capacitors are fully charged, the voltage across the capacitor C_1 will be 4 V.
- (B) The key S_1 is kept closed for long time such that capacitors are fully charged. Now key S_2 is closed, at this time, the instantaneous current across 30Ω resistor (between points P and Q) will be 0.2 A (round off to 1st decimal place).
- (C) At time $t = 0$, the key S_1 is closed, the instantaneous current in the closed circuit will be 25 mA.
- (D) If key S_1 is kept closed for long time such that capacitors are fully charged, the voltage difference between point P and Q will be 10 V.

Answer (A, C)

Sol.

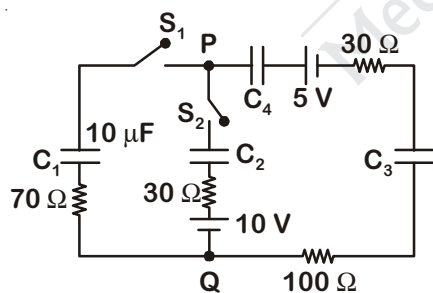

When switch S_1 is closed, so the equivalent circuit at $t = 0$ is

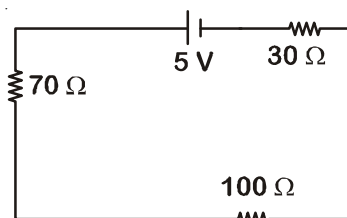

$$\therefore I = \frac{5}{200} = 25 \text{ mA}$$

At steady state for S_1 closed is

$$C_{eq} = 8 \mu\text{F} \text{ and } Q = 40 \mu\text{C}$$

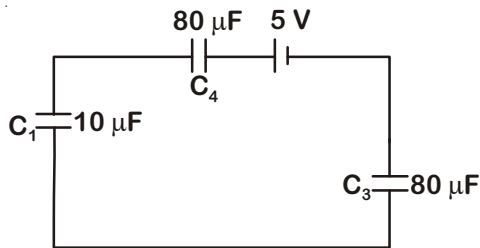

$$\therefore V(C_1) = 4 \text{ volt}; V(C_3) = V(C_4) = 0.5 \text{ volt}$$

At steady state potential difference between 'P' and 'Q' is 4 volt.

Now when switch S_2 is closed (Then equivalent circuit)

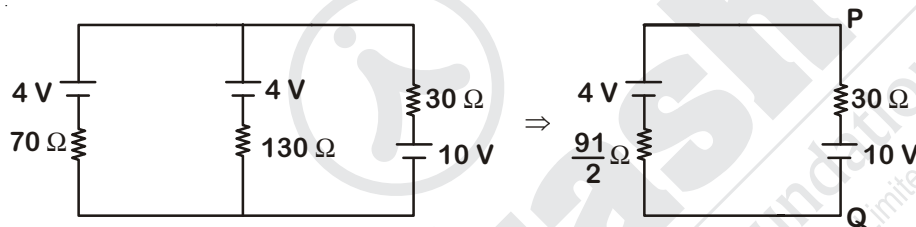

$$\therefore I_{PQ} = \frac{6 \times 2}{151} = 0.08 \text{ A}$$

Final answer (A, C)

4. A charged shell of radius R carries a total charge Q . Given Φ as the flux of electric field through a closed cylindrical surface of height h , radius r and with its centre same as that of the shell. Here, center of the cylinder is a point on the axis of the cylinder which is equidistant from its top and bottom surfaces. Which of the following option(s) is/are correct?

$[\epsilon_0$ is the permittivity of free space]

- (A) If $h > 2R$ and $r = 3R/5$ then $\Phi = Q/5\epsilon_0$ (B) If $h < 8R/5$ and $r = 3R/5$ then $\Phi = 0$
 (C) If $h > 2R$ and $r > R$ then $\Phi = Q/\epsilon_0$ (D) If $h > 2R$ and $r = 4R/5$ then $\Phi = Q/5\epsilon_0$

Answer (A, B, C)

Sol. For option (A) : $\left(h > 2R \quad r = \frac{3R}{5} \right)$

$$\sin \alpha = \frac{r}{R} = \frac{3}{5}$$

$$\cos \alpha = \frac{4}{5}$$

$$Q_{\text{enclosed}} = \frac{Q}{5}$$

$$\therefore \phi = \frac{Q}{5\epsilon_0}$$

For option (B) : $h < \frac{8R}{5}$, $r = \frac{3R}{5}$

$$Q_{\text{enclosed}} = 0$$

$$\text{and } \phi = 0$$

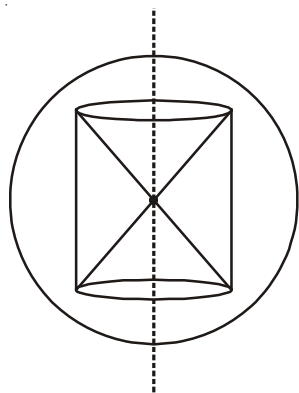

For option (C) : ($h > 2R$ and $r > R$)

$$Q_{\text{enclosed}} = Q$$

$$\therefore \phi = \frac{Q}{\epsilon_0}$$

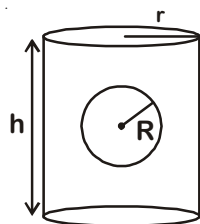

For option (D) : $h > 2R$ $r = \frac{4R}{5}$

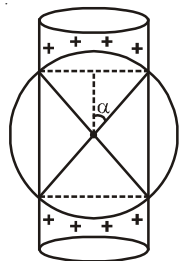

$$Q_{\text{enclosed}} = Q[1 - \cos \alpha]$$

$$\sin \alpha = \frac{r}{R} = \frac{3}{5}$$

$$\text{and } \cos \alpha = \frac{3}{5} \quad Q_{\text{enclosed}} = \frac{2Q}{5}$$

$$\therefore \phi = \frac{2Q}{5\epsilon_0}$$

5. One mole of a monatomic ideal gas goes through a thermodynamic cycle, as shown in the volume versus temperature (V - T) diagram. The correct statement(s) is/are
[R is the gas constant]

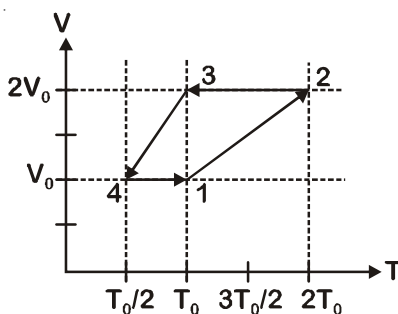

(A) The above thermodynamic cycle exhibits only isochoric and adiabatic processes

(B) The ratio of heat transfer during processes $1 \rightarrow 2$ and $3 \rightarrow 4$ is $\frac{Q_{1 \rightarrow 2}}{Q_{3 \rightarrow 4}} = \frac{1}{2}$

(C) The ratio of heat transfer during processes $1 \rightarrow 2$ and $2 \rightarrow 3$ is $\frac{Q_{1 \rightarrow 2}}{Q_{2 \rightarrow 3}} = \frac{5}{3}$

(D) Work done in this thermodynamic cycle ($1 \rightarrow 2 \rightarrow 3 \rightarrow 4 \rightarrow 1$) is $|W| = \frac{1}{2}RT_0$

Answer (C, D)

Sol. $|\Delta Q_{(1 \rightarrow 2)}| = nC_p dT = n \times \frac{5}{2} R \times T_0 = \frac{5RT_0}{2}$

$|\Delta Q_{3 \rightarrow 4}| = nC_p dT = n \times \frac{5}{2} R \frac{T_0}{2} = \frac{5RT_0}{4}$

$\frac{|\Delta Q_{1 \rightarrow 2}|}{|\Delta Q_{3 \rightarrow 4}|} = 2$ Also $|\Delta Q_{2 \rightarrow 3}| = \frac{3}{2} RT_0$

$\frac{(\Delta Q_{1 \rightarrow 2})}{(\Delta Q_{2 \rightarrow 3})} = \frac{5RT_0 \times 2}{2 \times 3RT_0} = \frac{5}{3}$

$w = \sum \Delta Q$
 $= \frac{RT_0}{2}$

6. Two identical moving coil galvanometers have 10Ω resistance and full scale deflection at $2 \mu A$ current. One of them is converted into a voltmeter of 100 mV full scale reading and the other into an Ammeter of 1 mA full scale current using appropriate resistors. These are then used to measure the voltage and current in the Ohm's law experiment with $R = 1000 \Omega$ resistor by using an ideal cell. Which of the following statements(s) is/are correct?

(A) The measured value of R will be $978 \Omega < R < 982 \Omega$

(B) The resistance of the ammeter will be 0.02Ω (round off to 2nd decimal place)

(C) If the ideal cell is replaced by a cell having internal resistance of 5Ω then the measured value of R will be more than 1000Ω

(D) The resistance of the voltmeter will be $100 \text{ k}\Omega$

Answer (A, B)

Sol. Maximum coil current $I_c = 2 \times 10^{-6}$ A, $R_c = 10 \Omega$

$$\therefore V_{\max} \text{ across coil} = 2 \times 10^{-6} \times 10 = 2 \times 10^{-5} \text{ volt.}$$



$$(10 + R_0) \times 2 \times 10^{-6} = 100 \times 10^{-3}$$

$$\Rightarrow R_0 = 49990 \Omega$$

And when converted into ammeter of range 1 mA, then

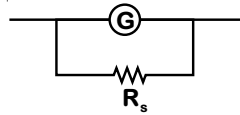

$$R_s \times 9.98 \times 10^{-4} = 2 \times 10^{-5} \Omega$$

$$\Rightarrow R_s = 0.02 \Omega$$

Now,

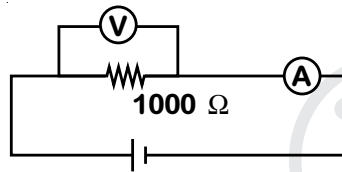

$$\therefore R_{\text{eq}} = 980.48 \Omega$$

$$\therefore I = \frac{V_0}{980.48}$$



$$\text{and } V' = \frac{V_0 \times 50000}{980.48 \times 51}$$

$$R_{\text{(measured)}} = \frac{V'}{I} = \frac{50000}{51} = 980.4 \Omega$$

7. A thin convex lens is made of two materials with refractive indices n_1 and n_2 , as shown in figure. The radius of curvature of the left and right spherical surfaces are equal. f is the focal length of the lens when $n_1 = n_2 = n$. The focal length is $f + \Delta f$ when $n_1 = n$ and $n_2 = n + \Delta n$. Assuming $\Delta n \ll (n - 1)$ and $1 < n < 2$, the correct statement(s) is/are,

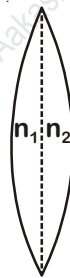

(A) $\left| \frac{\Delta f}{f} \right| < \left| \frac{\Delta n}{n} \right|$

- (B) The relation between $\frac{\Delta f}{f}$ and $\frac{\Delta n}{n}$ remains unchanged if both the convex surfaces are replaced by concave surfaces of the same radius of curvature.

(C) If $\frac{\Delta n}{n} < 0$ then $\frac{\Delta f}{f} > 0$

- (D) For $n = 1.5$, $\Delta n = 10^{-3}$ and $f = 20$ cm, the value of $|\Delta f|$ will be 0.02 cm (round off to 2nd decimal place).

Answer (B, C, D)

Sol. $\frac{1}{f} = (n_1 - 1) \left(\frac{1}{R} - \frac{1}{\infty} \right) + (n_2 - 1) \left(\frac{1}{\infty} - \frac{1}{-R} \right)$

$$\frac{1}{f} = \frac{(n_1 - 1)}{R} + \frac{n_2 - 1}{R} = \frac{(n_1 + n_2 - 2)}{R}$$

Now $\frac{\Delta f}{f^2} = \frac{\Delta n}{R}$

$$\frac{\Delta f}{f} = \frac{\Delta n}{(n_1 + n_2 - 2)} = \frac{\Delta n}{[2n + \Delta n - 2]}$$

For $n_1 = n_2 = 1.5$ $\Delta n = 10^{-3}$, $f = 20$ cm then $R = 20$ cm

and $\Delta f = \frac{10^{-3} \times 20}{(2 \times 1.5 - 2 + 10^{-3})} = 0.02$ cm.

If $\frac{\Delta n}{n} < 0$ (Diversing nature increases) $\therefore \frac{\Delta f}{f} > 0$

If the surfaces are replaced by concave surfaces of same radius, focal length changes the sign with same magnitude.

$\therefore \frac{\Delta f}{f} = \frac{\Delta n}{(2n + \Delta n - 2)}$ (remain unchanged).

8. Let us consider a system of units in which mass and angular momentum are dimensionless. If length has dimension of L, which of the following statement(s) is/are correct?

- (A) The dimension of force is L^{-3}
- (B) The dimension of power is L^{-5}
- (C) The dimension of linear momentum is L^{-1}
- (D) The dimension of energy is L^{-2}

Answer (A, C, D)

Sol. Angular momentum $\ell = MVR$

$\Rightarrow [\ell] = \frac{ML^2}{T}$ $\therefore M \rightarrow$ dimensionless

$\therefore T = L^2$ ℓ also dimensionless

Now $p = mv = \frac{ML}{T}$ $\therefore M$ (is) dimensionless

$\therefore [p] = L^{-1}$

$[\text{Energy}] = \frac{ML^2}{T^2} = \frac{L^2}{L^2 L^2} = L^{-2}$

$[\text{Power}] = \frac{ML^2}{T^2 T} = \frac{L^2}{L^2 L^2 L^2} = L^{-4}$

$[\text{Force}] = \frac{ML}{T^2} = \frac{L}{L^2 L^2} = L^{-3}$

SECTION - 3 (Maximum Marks : 18)

- This section contains SIX (06) questions. The answer to each question is a NUMERICAL VALUE.
- For each question, enter the correct numerical value of the answer using the mouse and the on-screen virtual numeric keypad in the place designated to enter the answer. If the numerical value has more than two decimal places, truncate/round-off the value to TWO decimal places.
- Answer to each question will be evaluated according to the following marking scheme:

Full Marks : +3 If ONLY the correct numerical value is entered.

Zero Marks : 0 In all other cases.

1. A particle is moved along a path AB-BC-CD-DE-EF-FA, as shown in figure, in presence of a force $\vec{F} = (\alpha y\hat{i} + 2\alpha x\hat{j})\text{N}$, where x and y are in meter and $\alpha = -1 \text{ Nm}^{-1}$. The work done on the particle by this force \vec{F} will be ___ Joule.

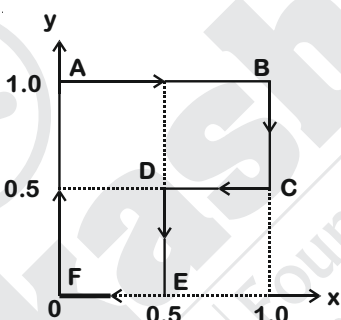

Answer (0.75)

Sol. $\vec{F} = \alpha y\hat{i} + 2\alpha x\hat{j}$

$$\alpha = -1 \quad \therefore \vec{F} = -[y\hat{i} + 2x\hat{j}]$$

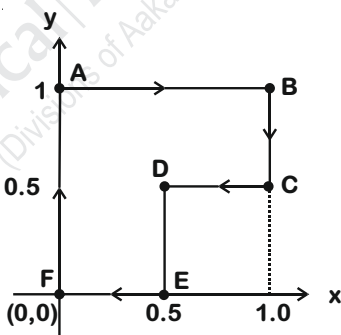

$$\int \vec{F} \cdot d\vec{l} = -(1 \times 1) + \left(2 \times \frac{1}{2}\right) + \left(\frac{1}{2} \times \frac{1}{2}\right) + \left(1 \times \frac{1}{2}\right)$$

$$= +0.75 \text{ J}$$

$$\Delta W = +0.75 \text{ J}$$

2. A block of weight 100 N is suspended by copper and steel wires of same cross sectional area 0.5 cm^2 and, length $\sqrt{3} \text{ m}$ and 1 m, respectively. Their other ends are fixed on a ceiling as shown in figure. The angles subtended by copper and steel wires with ceiling are 30° and 60° , respectively. If elongation in copper wire is (Δl_c) and elongation in steel wire is (Δl_s) , then the ratio $\frac{\Delta l_c}{\Delta l_s}$ is ____.
- [Young's modulus for copper and steel are $1 \times 10^{11} \text{ N/m}^2$ and $2 \times 10^{11} \text{ N/m}^2$, respectively.]

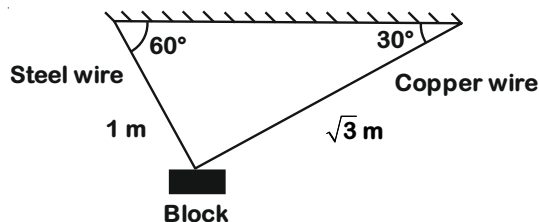

Answer (2.00)

Sol. $\frac{T_1}{2} = \frac{T_2\sqrt{3}}{2}$

$T_1 = \sqrt{3} T_2$

$\frac{\Delta l_2}{\Delta l_1} = \frac{T_2 l_2}{A_2 Y_2} \times \frac{A_1 Y_1}{T_1 l_1}$

$\frac{\Delta l_2}{\Delta l_1} = \frac{\sqrt{3} T_2}{T_1} \times \frac{2}{1} = 2$

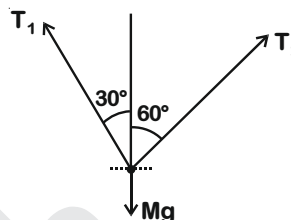

3. A liquid at 30°C is poured very slowly into a Calorimeter that is at temperature of 110°C. The boiling temperature of the liquid is 80°C. It is found that the first 5 gm of the liquid completely evaporates. After pouring another 80 gm of the liquid the equilibrium temperature is found to be 50°C. The ratio of the Latent heat of the liquid to its specific heat will be ____ °C.

[Neglect the heat exchange with surrounding]

Answer (270.00)

Sol. Case-I $5C \times 50 + 5L = C_2 \times 30 \dots(1)$

Case-II $80C [50-30] = C_2 [80-50] \dots(2)$

By equation (1) & (2)

$1600C = 250C + 5L$

$\therefore \frac{L}{C} = \frac{1350}{5} = 270^\circ\text{C}$

4. A planar structure of length L and width W is made of two different optical media of refractive indices $n_1 = 1.5$ and $n_2 = 1.44$ as shown in figure. If $L \gg W$, a ray entering from end AB will emerge from end CD only if the total internal reflection condition is met inside the structure, For $L = 9.6$ m, if the incident angle θ is varied, the maximum time taken by a ray to exit the plane CD is $t \times 10^{-9}$ s, where t is ____.

[Speed of light $c = 3 \times 10^8$ m/s]

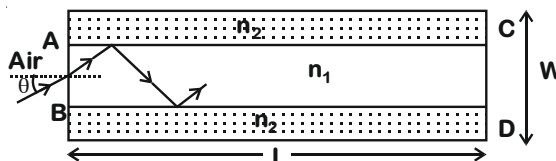

Answer (50.00)

Sol. $t = \frac{L}{v}$

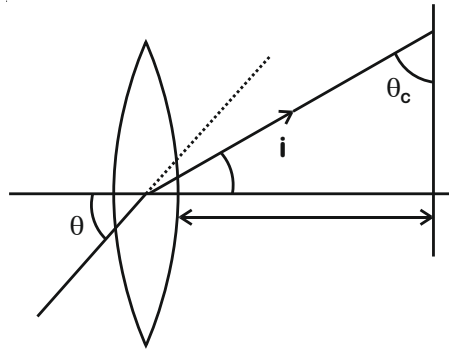

$$L = 9.6 / \sin \theta_c$$

$$\sin \theta_c = \frac{1.44}{1.50}$$

$$L = 10 \text{ m}$$

$$t_{\max} = \frac{10}{2 \times 10^8} = 5 \times 10^{-8} \text{ s} = 50 \times 10^{-9} \text{ s}$$

5. A parallel plate capacitor of capacitance C has spacing d between two plates having area A . The region between the plates is filled with N dielectric layers, parallel to its plates, each with thickness

$\delta = \frac{d}{N}$. The dielectric constant of the m^{th} layer is $K_m = K \left(1 + \frac{m}{N} \right)$. For a very large N ($> 10^3$), the

capacitance C is $\propto \left(\frac{K \epsilon_0 A}{d \ln 2} \right)$. The value of α will be _____.

$[\epsilon_0$ is the permittivity of free space]

Answer (1.00)

Sol. $dC = \frac{K \epsilon_0 A}{dx}$

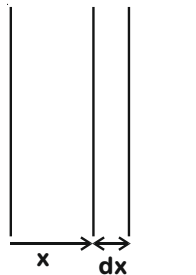

All are connected in series

$$\frac{1}{C} = \int \frac{1}{dc}$$

$$\frac{1}{C} = \int \frac{dx}{K \epsilon_0 A (1 + m/N)}$$

$$x = \frac{md}{N}$$

$$\frac{1}{C} = \int \frac{dx}{K\epsilon_0 A(1+x/d)}$$

$$\frac{1}{C} = \frac{d}{K\epsilon_0 A} \int_0^x \frac{dx}{d+x}$$

$$\frac{1}{C} = \frac{d \ln(2)}{K\epsilon_0 A}$$

$$C = \frac{K\epsilon_0 A}{d \ln(2)}$$

6. A train S1, moving with a uniform velocity of 108 km/h, approaches another train S2 standing on a platform. An observer O moves with a uniform velocity of 36 km/h towards S2, as shown in figure. Both the trains are blowing whistles of same frequency 120 Hz. When O is 600 m away from S2 and distance between S1 and S2 800 m, the number of beats heard by O is _____.
[Speed of the sound = 330 m/s]

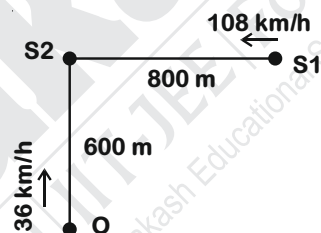

Answer (8.13)

Sol. $v_{\text{sound}} = 330 \text{ m/s}$

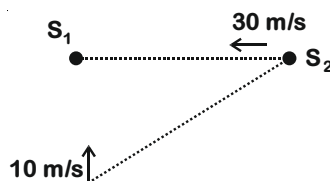

$$f_1 = 120 \left[\frac{330 + 10 \sin 53^\circ}{330 - 30 \cos 37^\circ} \right] \text{ Hz}$$

$$f_2 = 120 \left[\frac{330 + 10}{330} \right] \text{ Hz}$$

$$\Delta f = 120 \times \left[\frac{336}{306} - \frac{34}{33} \right]$$

$$= 8.13 \text{ Hz}$$

Sol. $\text{CuCO}_3 \cdot \text{Cu(OH)}_2 \rightarrow$ Malachite

$\text{Fe}_3\text{O}_4 \rightarrow$ Magnetite

$\text{ZnCO}_3 \rightarrow$ Calamine

$\text{Na}_3\text{AlF}_6 \rightarrow$ Cryolite

4. Molar conductivity (Λ_m) of aqueous solution of sodium stearate, which behaves as a strong electrolyte, is recorded at varying concentrations (c) of sodium stearate. Which one of the following plots provides the correct representation of micelle formation in the solution?

(critical micelle concentration (CMC) is marked with an arrow in the figures)

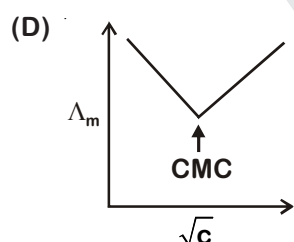
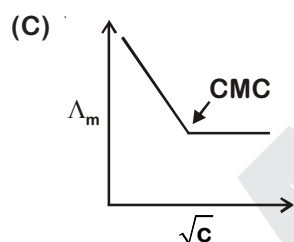
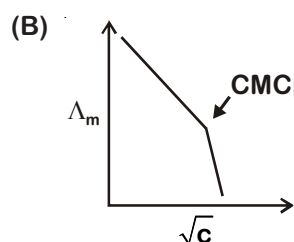
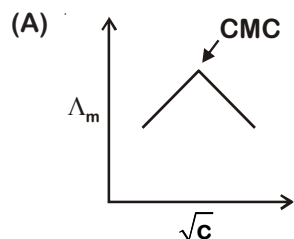

Answer (B)

Sol. Sodium stearate $\rightarrow \text{CH}_3(\text{CH}_2)_{16}\text{COO}^-\text{Na}^+$

At normal or low concentration, it behaves as strong electrolyte and for strong electrolyte, molar conductance (Λ_m) decreases with increase in concentration.

But only above particular concentration sodium stearate forms aggregates that concentration is called as CMC. Since number of ions decreases, hence Λ_m decreases.

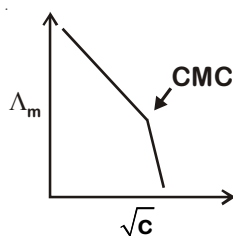

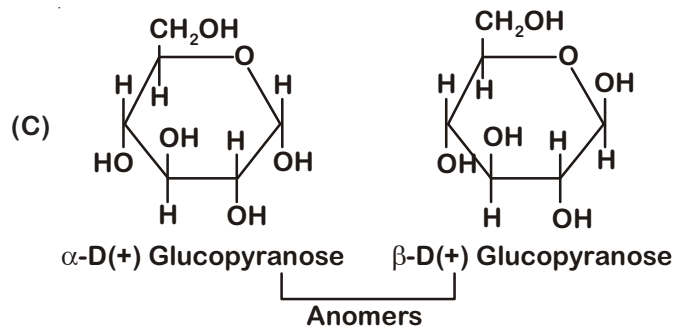

2. Which of the following statement(s) is(are) correct regarding the root mean square speed (U_{rms}) and average translational kinetic energy (ϵ_{av}) of a molecule in a gas at equilibrium?
- (A) U_{rms} is doubled when its temperature is increased four times
 (B) ϵ_{av} is doubled when its temperature is increased four times
 (C) ϵ_{av} at a given temperature does not depend on its molecular mass
 (D) U_{rms} is inversely proportional to the square root of its molecular mass

Answer (A, C, D)

Sol. $\bar{E}_k = \frac{3}{2}KT$ Average kinetic energy depends only on absolute temperature

K = Boltzmann constant

$$U_{\text{rms}} = \sqrt{\frac{3RT}{M}} \quad U_{\text{rms}} \propto \sqrt{T}$$

$$U_{\text{rms}} \propto \frac{1}{\sqrt{M}}$$

Using above formulae, correct statements are (A, C, D).

3. A tin chloride Q undergoes the following reactions (not balanced)

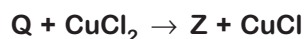

X is a monoanion having pyramidal geometry. Both Y and Z are neutral compounds. Choose the correct option(s).

- (A) The oxidation state of the central atom in Z is +2
 (B) The central atom in X is sp^3 hybridized
 (C) The central atom in Z has one lone pair of electrons
 (D) There is a coordinate bond in Y

Answer (B, D)

Sol. Compound Q is SnCl_2 . The given reactions are

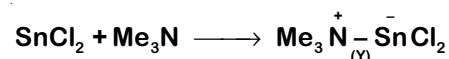
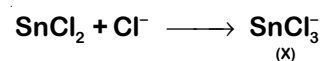

Hybridisation of Sn in SnCl_3^- is sp^3

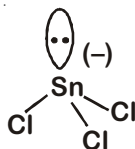

Trimethylamine forms a co-ordinate bond with Sn in SnCl_2 .

There is no lone pair on central atom of SnCl_4 (Z).

4. Fusion of MnO_2 with KOH in presence of O_2 produces a salt W. Alkaline solution of W upon electrolytic oxidation yields another salt X. The manganese containing ions present in W and X, respectively, are Y and Z. Correct statement(s) is(are)

- (A) Both Y and Z are coloured and have tetrahedral shape
 (B) In aqueous acidic solution, Y undergoes disproportionation reaction to give Z and MnO_2
 (C) Y is diamagnetic in nature while Z is paramagnetic
 (D) In both Y and Z, π -bonding occurs between p -orbitals of oxygen and d -orbitals of manganese

Answer (A, B, D)

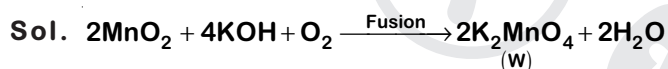

Electrolysis of aq K_2MnO_4 oxidises MnO_4^{2-} to MnO_4^-

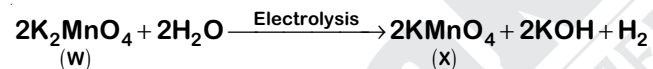

K_2MnO_4 in acidic medium undergoes disproportionation

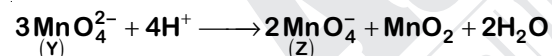

K_2MnO_4 is green in colour and KMnO_4 is in purple colour. Both are tetrahedral in shape involving $p\pi - d\pi$ bond.

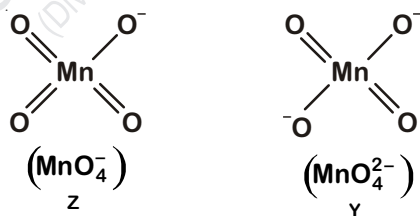

5. Choose the reaction(s) from the following options, for which the standard enthalpy of reaction is equal to the standard enthalpy of formation.

- (A) $\frac{1}{8}\text{S}_8(\text{s}) + \text{O}_2(\text{g}) \rightarrow \text{SO}_2(\text{g})$
 (B) $2\text{H}_2(\text{g}) + \text{O}_2(\text{g}) \rightarrow 2\text{H}_2\text{O}(\text{l})$
 (C) $2\text{C}(\text{g}) + 3\text{H}_2(\text{g}) \rightarrow \text{C}_2\text{H}_6(\text{g})$
 (D) $\frac{3}{2}\text{O}_2(\text{g}) \rightarrow \text{O}_3(\text{g})$

Answer (A, D)

Sol. Since standard enthalpy of formation of a compound is the change in the standard enthalpy when one mole of the compound is formed starting from requisite amount of constituent elements in standard state.

Hence only (A) and (D) options are correct.

6. In the decay sequence,

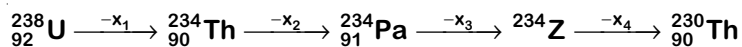

x_1, x_2, x_3 and x_4 are particles/radiation emitted by the respective isotopes. The correct option(s) is(are)

(A) x_3 is γ -ray

(B) Z is an isotope of uranium

(C) x_1 will deflect towards negatively charged plate

(D) x_2 is β^-

Answer (B, C, D)

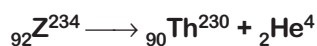
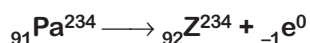
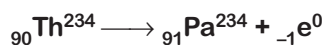
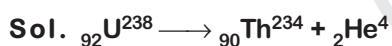

$$\therefore x_1 = \alpha; x_2 = x_3 = {}_{-1}\beta^0; x_4 = \alpha$$

Z has atomic number 92.

7. Choose the correct option(s) for the following set of reactions

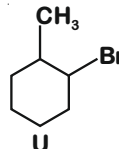
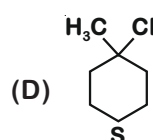
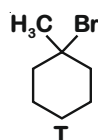
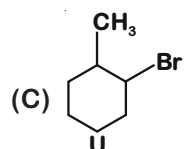
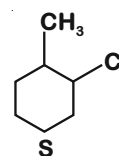
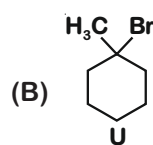
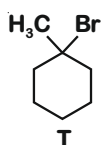
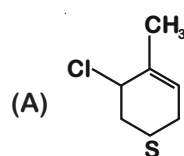
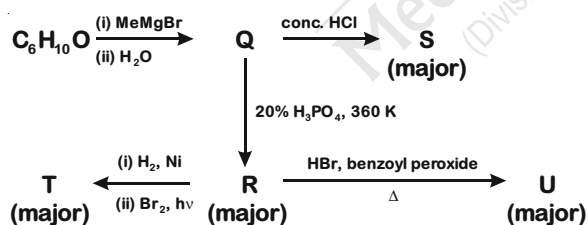

Answer (C, D)

Sol.

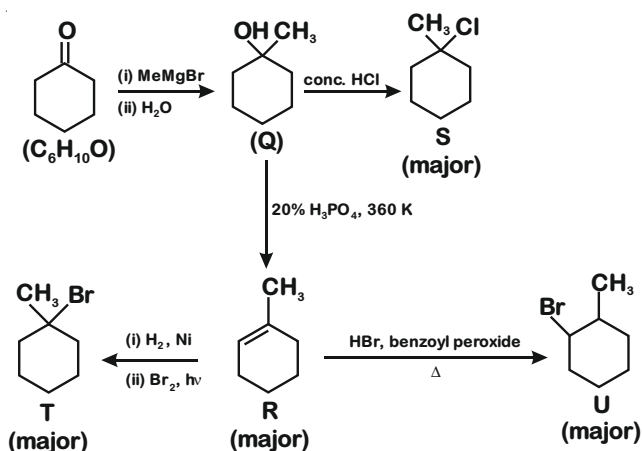

8. Each of the following options contains a set of four molecules. Identify the options(s) where all four molecules possess permanent dipole moment at room temperature.

- (A) BF_3 , O_3 , SF_6 , XeF_6 (B) SO_2 , C_6H_5Cl , H_2Se , BrF_5
 (C) NO_2 , NH_3 , $POCl_3$, CH_3Cl (D) $BeCl_2$, CO_2 , BCl_3 , $CHCl_3$

Answer (B, C)

Sol. For symmetrical molecule $\mu = 0$

For unsymmetrical molecule $\mu \neq 0$

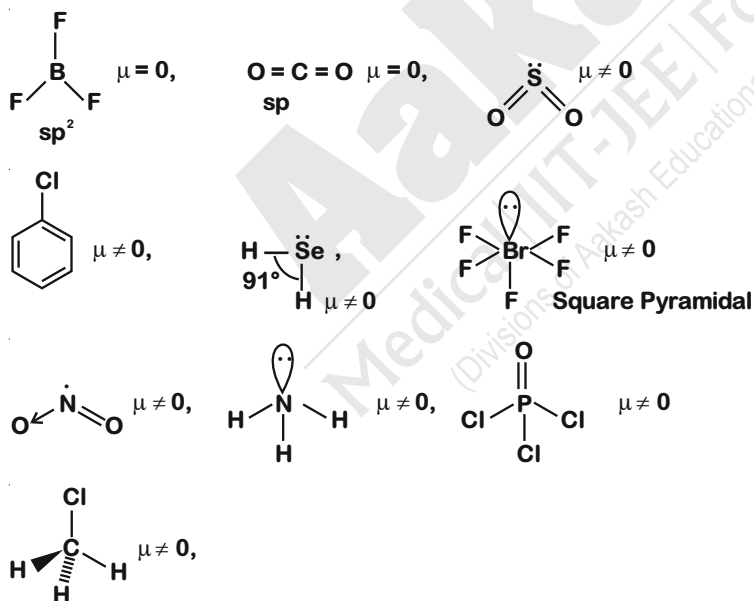

SECTION - 3 (Maximum Marks : 18)

- This section contains SIX (06) questions. The answer to each question is a NUMERICAL VALUE.
- For each question, enter the correct numerical value of the answer using the mouse and the on-screen virtual numeric keypad in the place designated to enter the answer. If the numerical value has more than two decimal places, truncate/round-off the value to TWO decimal places.
- Answer to each question will be evaluated according to the following marking scheme:

Full Marks : +3 If ONLY the correct numerical value is entered.

Zero Marks : 0 In all other cases.

1. Among B_2H_6 , $B_3N_3H_6$, N_2O , N_2O_4 , $H_2S_2O_3$ and $H_2S_2O_8$, the total number of molecules containing covalent bond between two atoms of the same kind is _____

Answer (4.00)

Sol.

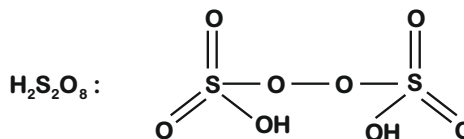
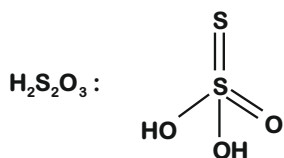
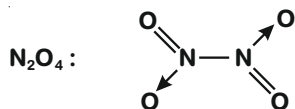

∴ Number of compounds having bond between same type of atoms = 4

2. At 143 K, the reaction of XeF_4 with O_2F_2 produces a xenon compound Y. The total number of lone pair(s) of electrons present on the whole molecule of Y is _____

Answer (19.00)

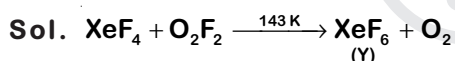

3. Schemes 1 and 2 describe the conversion of P to Q and R to S, respectively. Scheme 3 describes the synthesis of T from Q and S. The total number of Br atoms in a molecule of T is _____

Scheme 1:

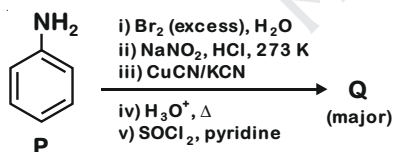

Scheme 2:

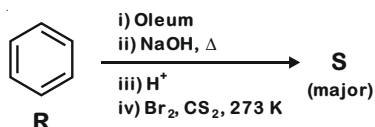

Scheme 3:

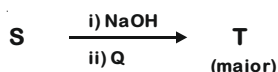

Answer (4.00)

Sol.

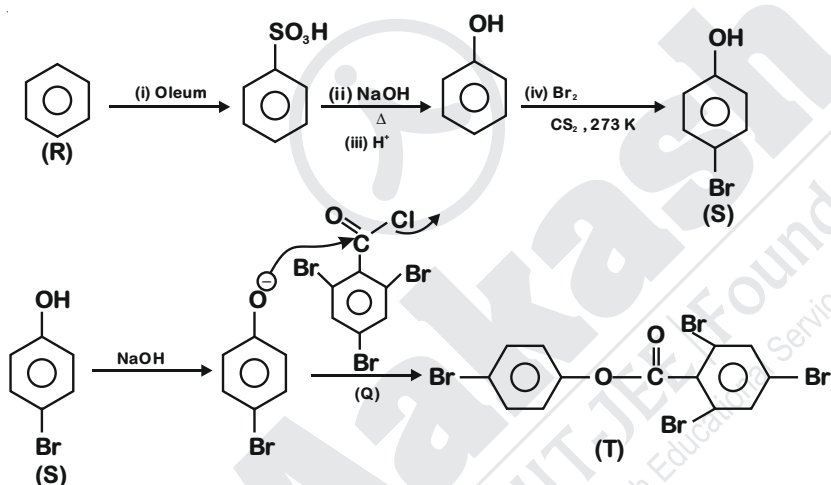
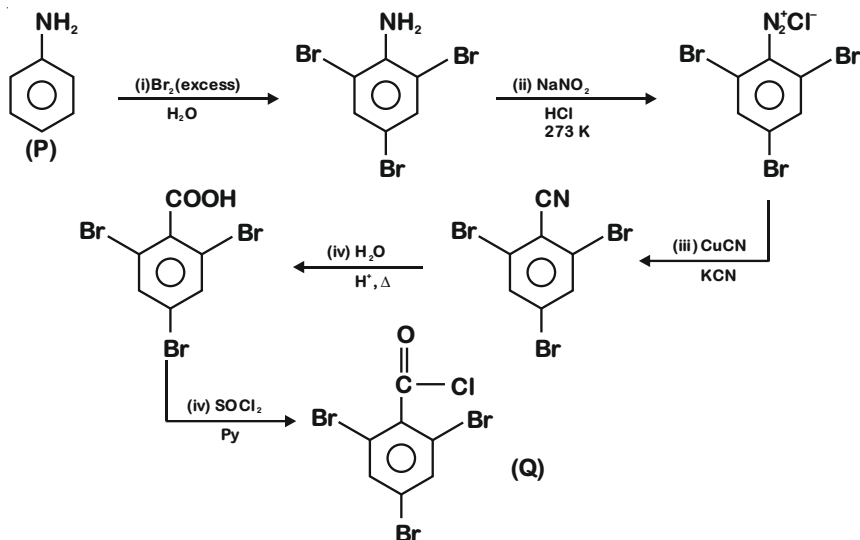

4. On dissolving 0.5 g of a non-volatile non-ionic solute to 39 g of benzene, its vapor pressure decreases from 650 mm Hg to 640 mm Hg. The depression of freezing point of benzene (in K) upon addition of the solute is _____

(Given data: Molar mass and the molal freezing point depression constant of benzene are 78 g mol^{-1} and $5.12\text{ K kg mol}^{-1}$, respectively)

Answer (1.02)

$$\text{Sol. } \therefore \frac{P^\circ - P}{P^\circ} = x_{\text{solute}} = \frac{n_{\text{solute}}}{n_{\text{solute}} + n_{\text{solvent}}}$$

$$\Rightarrow \frac{10}{650} = \frac{n_{\text{solute}}}{n_{\text{solute}} + 0.5} \Rightarrow n_{\text{solute}} + 0.5 = 65 n_{\text{solute}}$$

$$\Rightarrow n_{\text{solute}} = \frac{0.5}{64} = \frac{1}{2 \times 64}$$

$$\Delta T_f = K_f \cdot m$$

$$= 5.12 \times 1000 \times \frac{1}{2 \times 64 \times 39}$$

$$= 1.02\text{ K}$$

5. Consider the kinetic data given in the following table for the reaction $A + B + C \rightarrow \text{Product}$.

Experiment No	[A] (mol dm ⁻³)	[B] (mol dm ⁻³)	[C] (mol dm ⁻³)	Rate of reaction (mol dm ⁻³ s ⁻¹)
1	0.2	0.1	0.1	6.0×10^{-5}
2	0.2	0.2	0.1	6.0×10^{-5}
3	0.2	0.1	0.2	1.2×10^{-4}
4	0.3	0.1	0.1	9.0×10^{-5}

The rate of the reaction for $[A] = 0.15 \text{ mol dm}^{-3}$, $[B] = 0.25 \text{ mol dm}^{-3}$ and $[C] = 0.15 \text{ mol dm}^{-3}$ is found to be $Y \times 10^{-5} \text{ mol dm}^{-3} \text{ s}^{-1}$. The value of Y is _____

Answer (6.75)

Sol. $A + B + C \rightarrow \text{Product}$

$$\text{Rate} \propto [A]^x [B]^y [C]^z$$

$$\frac{R_1}{R_2} = \frac{(0.2)^x (0.1)^y (0.1)^z}{(0.2)^x (0.2)^y (0.1)^z} = \frac{6 \times 10^{-5}}{6 \times 10^{-5}}$$

$$\therefore y = 0$$

Similarly x and z are calculated, $x = 1$, $z = 1$

$$\text{Rate constant } K = \frac{6 \times 10^{-5}}{0.2 \times 0.1} = 3 \times 10^{-3}$$

$$\begin{aligned} \therefore \text{Rate at given concentrations} &= 3 \times 10^{-3} \times (0.15)^1 (0.25)^0 (0.15)^1 \\ &= 6.75 \times 10^{-5} \text{ mol dm}^{-3} \text{ s}^{-1} \end{aligned}$$

$$Y = 6.75$$

6. For the following reaction, the equilibrium constant K_c at 298 K is 1.6×10^{17} .



When equal volumes of 0.06 M $\text{Fe}^{2+}(\text{aq})$ and 0.2 M $\text{S}^{2-}(\text{aq})$ solutions are mixed, the equilibrium concentration of $\text{Fe}^{2+}(\text{aq})$ is found to be $Y \times 10^{-17}$ M. The value of Y is _____

Answer (8.93)

Sol. $\text{Fe}^{2+}(\text{aq}) + \text{S}^{2-}(\text{aq}) \rightleftharpoons \text{FeS}(\text{s}), \quad K = 1.6 \times 10^{17}$

t_0	0.03	0.1	-
t_{eq}	x	$0.1 - 0.03$ ≈ 0.07	-

$$\therefore x(0.07) = \frac{1}{1.6} \times 10^{-17}$$

$$\Rightarrow x \approx 8.93 \times 10^{-17} \text{ M}$$

$$\therefore Y = 8.93$$

PART-III : MATHEMATICS

SECTION - 1 (Maximum Marks : 12)

- This section contains **FOUR (04)** questions.
- Each question has **FOUR** options. **ONLY ONE** of these four options is the correct answer.
- For each question, choose the option corresponding to the correct answer.
- Answer to each question will be evaluated according to the following marking scheme:

Full Marks : +3 If **ONLY** the correct option is chosen;
Zero Marks : 0 If none of the options is chosen (i.e. the question is unanswered);
Negative Marks : -1 In all other cases.

1. Let S be the set of all complex numbers z satisfying $|z - 2 + i| \geq \sqrt{5}$. If the complex number z_0 is such

that $\frac{1}{|z_0 - 1|}$ is the maximum of the set $\left\{ \frac{1}{|z - 1|} : z \in S \right\}$, then the principal argument of $\frac{4 - z_0 - \bar{z}_0}{z_0 - \bar{z}_0 + 2i}$ is

- (A) $\frac{\pi}{2}$ (B) $\frac{\pi}{4}$ (C) $-\frac{\pi}{2}$ (D) $\frac{3\pi}{4}$

Answer (C)

Sol. $|z - 2 + i| \geq \sqrt{5}$

$\frac{1}{|z_0 - 1|}$ is maximum

when $|z_0 - 1|$ is minimum

Let $z_0 = x + iy$

$$x < 1 \text{ and } y > 0$$

$$\frac{4 - z_0 - \bar{z}_0}{z_0 - \bar{z}_0 + 2i}$$

$$= \frac{4 - x - iy - x + iy}{x + iy - x + iy + 2i}$$

$$= \frac{4 - 2x}{(y + 1)2i} = \frac{-i(2 - x)}{(y + 1)}$$

$\therefore \frac{2 - x}{y + 1}$ is a positive real number

$$\Rightarrow \arg\left(\frac{4 - z_0 - \bar{z}_0}{z_0 - \bar{z}_0 + 2i}\right) = -\frac{\pi}{2}$$

2. Let

$$M = \begin{bmatrix} \sin^4 \theta & -1 - \sin^2 \theta \\ 1 + \cos^2 \theta & \cos^4 \theta \end{bmatrix} = \alpha I + \beta M^{-1},$$

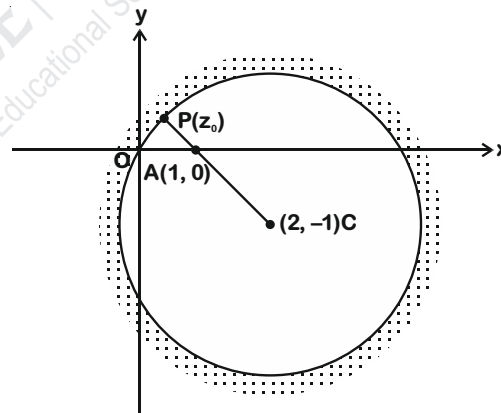

where $\alpha = \alpha(\theta)$ and $\beta = \beta(\theta)$ are real numbers, and I is the 2×2 identity matrix. If α^* is the minimum of the set $\{\alpha(\theta) : \theta \in [0, 2\pi)\}$ and β^* is the minimum of the set $\{\beta(\theta) : \theta \in [0, 2\pi)\}$, then the value of $\alpha^* + \beta^*$ is

- (A) $-\frac{17}{16}$ (B) $-\frac{29}{16}$ (C) $-\frac{31}{16}$ (D) $-\frac{37}{16}$

Answer (B)

Sol. $M = \begin{bmatrix} \sin^4 \theta & -1 - \sin^2 \theta \\ 1 + \cos^2 \theta & \cos^4 \theta \end{bmatrix} = \alpha I + \beta M^{-1}$

$\therefore \det(M) = |M| = \sin^4 \theta \cdot \cos^4 \theta + \sin^2 \theta \cos^2 \theta + 2$

$= \left\{ \left(\sin^2 \theta \cos^2 \theta + \frac{1}{2} \right)^2 + \frac{7}{4} \right\}$

$\begin{bmatrix} \sin^4 \theta & -1 - \sin^2 \theta \\ 1 + \cos^2 \theta & \cos^4 \theta \end{bmatrix} = \begin{bmatrix} \alpha & 0 \\ 0 & \alpha \end{bmatrix} + \frac{\beta}{|M|} \begin{bmatrix} \cos^4 \theta & 1 + \sin^2 \theta \\ -1 - \cos^2 \theta & \sin^4 \theta \end{bmatrix}$

$\therefore \alpha = \cos^4 \theta + \sin^4 \theta = 1 - \frac{1}{2}(\sin^2 2\theta)$

and $\beta = -|M|$

$= - \left\{ \left(\sin^2 \theta \cdot \cos^2 \theta + \frac{1}{2} \right)^2 + \frac{7}{4} \right\}$

$\therefore \alpha_{\min} = \frac{1}{2}$ and $\beta_{\min} = -\frac{37}{16}$

$\therefore \alpha^* + \beta^* = \frac{1}{2} - \frac{37}{16} = -\frac{29}{16}$

3. The area of the region $\{(x, y) : xy \leq 8, 1 \leq y \leq x^2\}$ is

- (A) $8 \log_e 2 - \frac{7}{3}$ (B) $16 \log_e 2 - 6$ (C) $8 \log_e 2 - \frac{14}{3}$ (D) $16 \log_e 2 - \frac{14}{3}$

Answer (D)

Sol.

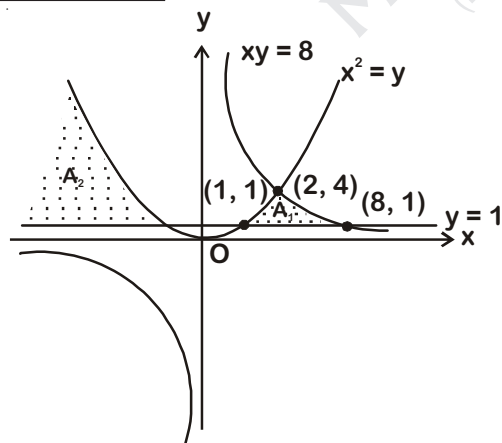

Area of region $A_1 = \int_1^2 (x^2 - 1) dx + \int_2^8 \left(\frac{8}{x} - 1 \right) dx$

$= \left[\frac{x^3}{3} - x \right]_1^2 + [8 \ln |x| - x]_2^8$

$$= \frac{8}{3} - 2 - \frac{1}{3} + 1 + 8 \ln 8 - 8 - 8 \ln 2 + 2$$

$$= \frac{-14}{3} + 16 \ln 2$$

Note : As the required area is also consisting of the area of the region A_2 , which is unbounded. However we have calculated the area of the region A_1 .

4. A line $y = mx + 1$ intersects the circle $(x - 3)^2 + (y + 2)^2 = 25$ at the points P and Q. If the midpoint of the line segment PQ has x-coordinate $-\frac{3}{5}$, then which one of the following options is correct?
- (A) $2 \leq m < 4$ (B) $4 \leq m < 6$ (C) $6 \leq m < 8$ (D) $-3 \leq m < -1$

Answer (A)

Sol. The mid-point of chord PQ can be considered as $A\left(-\frac{3}{5}, -\frac{3}{5}m+1\right)$

$\therefore AO \perp PQ$

Slope of AO \times Slope of PQ = -1

$$\Rightarrow \left(\frac{1 - \frac{3}{5}m + 2}{-\frac{3}{5} - 3} \right) \cdot m = -1$$

$$\Rightarrow \left(3 - \frac{3}{5}m \right) m = \frac{18}{5}$$

$$\Rightarrow m^2 - 5m + 6 = 0$$

$$\Rightarrow m = 2 \text{ or } 3$$

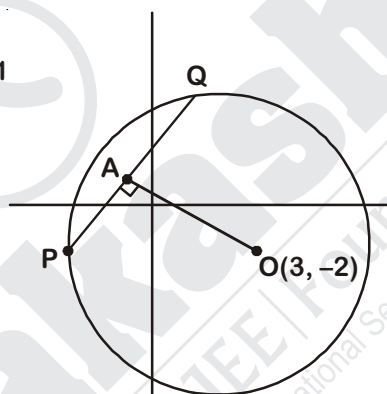

SECTION - 2 (Maximum Marks : 32)

- This section contains **EIGHT (08)** questions.
- Each question has **FOUR** options. **ONE OR MORE THAN ONE** of these four option(s) is(are) correct answer(s).
- For each question, choose the option(s) corresponding to (all) the correct answer(s).
- Answer to each question will be evaluated according to the following marking scheme:

Full Marks : +4 If only (all) the correct option(s) is(are) chosen;

Partial Marks : +3 If all the four options are correct but **ONLY** three options are chosen;

Partial Marks : +2 If three or more options are correct but **ONLY** two options are chosen, and both of which are correct;

Partial Marks : +1 If two or more options are correct but **ONLY** one option is chosen and it is a correct option;

Zero Marks : 0 If none of the options is chosen (i.e. the question is unanswered);

Negative Marks : -1 In all other cases.

- For example : in a question, if (A), (B) and (D) are the **ONLY** three options corresponding to correct answers, then

choosing **ONLY** (A), (B) and (D) will get +4 marks;

choosing **ONLY** (A) and (B) will get +2 marks;

- choosing ONLY (A) and (D) will get +2 marks;
- choosing ONLY (B) and (D) will get +2 marks;
- choosing ONLY (A) will get +1 mark;
- choosing ONLY (B) will get +1 mark;
- choosing ONLY (D) will get +1 mark;
- choosing no option (i.e., the question is unanswered) will get 0 marks; and
- choosing any other combination of options will get -1 mark.

1. There are three bags B_1 , B_2 and B_3 . The bag B_1 contains 5 red and 5 green balls, B_2 contains 3 red and 5 green balls, and B_3 contains 5 red and 3 green balls. Bags B_1 , B_2 and B_3 have probabilities $\frac{3}{10}$, $\frac{3}{10}$ and $\frac{4}{10}$ respectively of being chosen. A bag is selected at random and a ball is chosen at random from the bag. Then which of the following options is/are correct?
- (A) Probability that the selected bag is B_3 and the chosen ball is green equals $\frac{3}{10}$
- (B) Probability that the selected bag is B_3 , given that the chosen ball is green, equals $\frac{5}{13}$
- (C) Probability that the chosen ball is green, given that the selected bag is B_3 , equals $\frac{3}{8}$
- (D) Probability that the chosen ball is green equals $\frac{39}{80}$

Answer (C, D)

Sol.

$\begin{matrix} 5R \\ 5G \end{matrix}$	$\begin{matrix} 3R \\ 5G \end{matrix}$	$\begin{matrix} 5R \\ 3G \end{matrix}$
B_1	B_2	B_3
$P(B_1) = \frac{3}{10}$	$P(B_2) = \frac{3}{10}$	$P(B_3) = \frac{4}{10}$

- (A) Probability that selected bag is B_3 and the chosen ball is green

$$= P(B_3) \times P\left(\frac{G}{B_3}\right)$$

$$= \frac{4}{10} \times \frac{3}{8} = \frac{3}{20}$$

- (B) Probability that the selected bag is B_3 given that the chosen ball is green $P\left(\frac{B_3}{G}\right)$

$$P\left(\frac{B_3}{G}\right) = \frac{P\left(\frac{G}{B_3}\right)P(B_3)}{P\left(\frac{G}{B_1}\right)P(B_1) + P\left(\frac{G}{B_2}\right)P(B_2) + P\left(\frac{G}{B_3}\right)P(B_3)}$$

$$= \frac{\frac{4}{10} \times \frac{3}{8}}{\frac{3}{10} \times \frac{5}{10} + \frac{3}{10} \times \frac{5}{8} + \frac{4}{10} \times \frac{3}{8}} = \frac{4}{13}$$

- (C) Probability that the chosen ball is green, given that the selected bag is B_3

$$P\left(\frac{G}{B_3}\right) = \frac{3}{8}$$

(D) Probability that the chosen ball is green

$$P(G) = P(B_1)P\left(\frac{G}{B_1}\right) + P(B_2)P\left(\frac{G}{B_2}\right) + P(B_3)P\left(\frac{G}{B_3}\right)$$

$$= \frac{3}{10} \times \frac{5}{10} + \frac{3}{10} \times \frac{5}{8} + \frac{4}{10} \times \frac{3}{8}$$

$$= \frac{39}{80}$$

2. Let $f : \mathbb{R} \rightarrow \mathbb{R}$ be given by

$$f(x) = \begin{cases} x^5 + 5x^4 + 10x^3 + 10x^2 + 3x + 1, & x < 0; \\ x^2 - x + 1, & 0 \leq x < 1; \\ \frac{2}{3}x^3 - 4x^2 + 7x - \frac{8}{3}, & 1 \leq x < 3; \\ (x-2)\log_e(x-2) - x + \frac{10}{3}, & x \geq 3. \end{cases}$$

Then which of the following options is/are correct?

- (A) f' has a local maximum at $x = 1$ (B) f' is NOT differentiable at $x = 1$
 (C) f is onto (D) f is increasing on $(-\infty, 0)$

Answer (A, B, C)

Sol. $f(x) = \begin{cases} x^5 + 5x^4 + 10x^3 + 10x^2 + 3x + 1, & x < 0 \\ x^2 - x + 1, & 0 \leq x < 1 \\ \frac{2}{3}x^3 - 4x^2 + 7x - \frac{8}{3}, & 1 \leq x < 3 \\ (x-2)\log_e(x-2) - x + \frac{10}{3}, & x \geq 3 \end{cases}$

Clearly $f(x)$ is continuous at $x = 0, 1$ and 3

$$\therefore f'(x) = \begin{cases} 5x^4 + 20x^3 + 30x^2 + 20x + 3, & x < 0 \\ 2x - 1, & 0 < x < 1 \\ 2x^2 - 8x + 7, & 1 < x < 3 \\ \log_e(x-2), & x > 3. \end{cases}$$

at $x = 1, f''(1^-) > 0$ and $f''(1^+) < 0$

$\therefore f(x)$ has local maxima at $x = 1$.

Option (A) is correct

and $f''(1^-) \neq f''(1^+)$

$\Rightarrow f'$ is not differentiable at $x = 1$

Option (B) is correct

$f(x)$ has range $(-\infty, \infty)$.

$\therefore f$ is onto \Rightarrow Option (C) is correct

For $x < 0, f'(x) = 5x^4 + 20x^3 + 30x^2 + 20x + 3$.

Here $f'(-1) < 0$

$\therefore f(x)$ is not monotonically increasing on $(-\infty, 0)$

3. Let Γ denote a curve $y = y(x)$ which is in the first quadrant and let the point $(1, 0)$ lie on it. Let the tangent of Γ at a point P intersect the y -axis at Y_P . If PY_P has length 1 for each point P on Γ , then which of the following options is/are correct?

(A) $xy' - \sqrt{1-x^2} = 0$

(B) $xy' + \sqrt{1-x^2} = 0$

(C) $y = \log_e \left(\frac{1 + \sqrt{1-x^2}}{x} \right) - \sqrt{1-x^2}$

(D) $y = -\log_e \left(\frac{1 + \sqrt{1-x^2}}{x} \right) + \sqrt{1-x^2}$

Answer (B, C)

Sol. Let point $P(x, y)$

Equation of tangent at P ;

$$Y - y = \frac{dy}{dx}(X - x)$$

So $Y_P \left(0, y - x \frac{dy}{dx} \right)$

$$PY_P = \sqrt{x^2 + \left(x \frac{dy}{dx} \right)^2} = 1$$

$$\Rightarrow \frac{dy}{dx} = \pm \frac{\sqrt{1-x^2}}{x}$$

$$\Rightarrow dy = \pm \left(\frac{\sqrt{1-x^2}}{x} \right) dx \quad \text{let } x = \sin\theta, dx = \cos\theta d\theta$$

$$\Rightarrow dy = \pm (\operatorname{cosec}\theta - \sin\theta) d\theta$$

$$\Rightarrow y = \pm [\ln(\operatorname{cosec}\theta - \cot\theta) + \cos\theta] + C$$

$$\Rightarrow y = \pm [-\ln(\operatorname{cosec}\theta + \cot\theta) + \cos\theta] + C$$

$$y = \pm \left[-\ln \left(\frac{1 + \sqrt{1-x^2}}{x} \right) + \sqrt{1-x^2} \right] + C$$

As the curve lies in the 1st quadrant so y must be positive

$$y = \ln \left(\frac{1 + \sqrt{1-x^2}}{x} \right) - \sqrt{1-x^2} + C$$

$$\therefore y(1) = 0 \Rightarrow C = 0$$

$$\Rightarrow y = \ln \left(\frac{1 + \sqrt{1-x^2}}{x} \right) - \sqrt{1-x^2}$$

Also the correct differential equation will be

$$\frac{dy}{dx} = -\frac{\sqrt{1-x^2}}{x}$$

$$\Rightarrow xy' + \sqrt{1-x^2} = 0$$

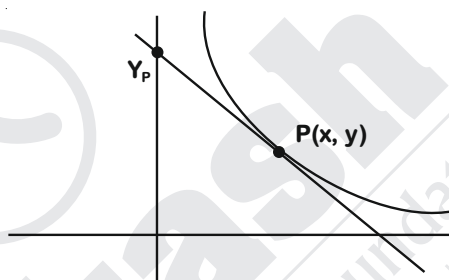

4. In a non-right-angled triangle ΔPQR , let p, q, r denote the lengths of the sides opposite to the angles at P, Q, R respectively. The median from R meets the side PQ at S , the perpendicular from P meets the side QR at E , and RS and PE intersect at O . If $p = \sqrt{3}$, $q = 1$, and the radius of the circumcircle of the ΔPQR equals 1, then which of the following options is/are correct?

(A) Area of $\Delta SOE = \frac{\sqrt{3}}{12}$

(B) Length of $RS = \frac{\sqrt{7}}{2}$

(C) Length of $OE = \frac{1}{6}$

(D) Radius of incircle of $\Delta PQR = \frac{\sqrt{3}}{2}(2 - \sqrt{3})$

Answer (B, C, D)

Sol. $\therefore \frac{p}{\sin P} = \frac{q}{\sin Q} = \frac{r}{\sin R} = 2 \times \text{circumradius (sine rule)}$

$$\Rightarrow \frac{\sqrt{3}}{\sin P} = \frac{1}{\sin Q} = \frac{r}{\sin R} = 2$$

Clearly, $P = 120^\circ, Q = 30^\circ$ and $R = 30^\circ$

So PQR is an isosceles triangle.

$r = 1$ and PE is also a median, so point 'O' is centroid.

(A) Area of $\Delta SOE = \frac{1}{2} OE \times ST$
 $= \frac{1}{2} \times \frac{1}{6} \times PS \sin 60^\circ$
 $= \frac{1}{12} \times \frac{1}{2} \times \frac{\sqrt{3}}{2}$
 $= \frac{\sqrt{3}}{48}$

(B) From Apollonius theorem

$$2(PS^2 + RS^2) = PR^2 + QR^2 \Rightarrow 2\left(\frac{1}{4} + RS^2\right) = 1 + 3 \Rightarrow RS = \frac{\sqrt{7}}{2}$$

(C) Again from Apollonius theorem

$$2(PE^2 + QE^2) = PQ^2 + PR^2 \Rightarrow 2\left(PE^2 + \frac{3}{4}\right) = 1 + 1 \Rightarrow PE = \frac{1}{2}$$

Also $OE = \frac{1}{3} PE = \frac{1}{6}$

(D) Inradius $= \frac{\Delta}{S} = \frac{\frac{1}{2} pq \sin R}{\frac{1}{2}(p+q+r)} = \frac{\frac{\sqrt{3} \times 1 \times \frac{1}{2}}{2}}{1+1+\sqrt{3}} = \frac{\sqrt{3}}{2}(2 - \sqrt{3})$

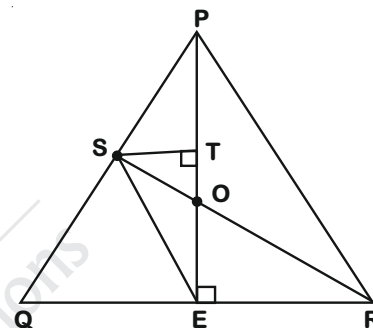

5. Let $M = \begin{bmatrix} 0 & 1 & a \\ 1 & 2 & 3 \\ 3 & b & 1 \end{bmatrix}$ and $\text{adj } M = \begin{bmatrix} -1 & 1 & -1 \\ 8 & -6 & 2 \\ -5 & 3 & -1 \end{bmatrix}$

where a and b are real numbers. Which of the following options is/are correct?

(A) $a + b = 3$

(B) $(\text{adj } M)^{-1} + \text{adj } M^{-1} = -M$

(C) If $M \begin{bmatrix} \alpha \\ \beta \\ \gamma \end{bmatrix} = \begin{bmatrix} 1 \\ 2 \\ 3 \end{bmatrix}$, then $\alpha - \beta + \gamma = 3$

(D) $\det(\text{adj } M^2) = 81$

Answer (A, B, C)

Sol. $|\text{adj } M| = |M|^2 = \begin{vmatrix} -1 & 1 & -1 \\ 8 & -6 & 2 \\ -5 & 3 & -1 \end{vmatrix} = -1(6-6) - 1(-8+10) - 1(24-30)$

$|M|^2 = -2 + 6 = 4 \Rightarrow |M| = \pm 2$

We know

$A \cdot (\text{adj } A) = |A| I$

So $M = |M| (\text{adj } M)^{-1} \dots(1)$

So $(\text{adj } M^{-1}) = \begin{bmatrix} 0 & -1 & -3 \\ -1 & -1 & -1 \\ -1 & -3 & -1 \end{bmatrix}^{-1} = \begin{bmatrix} 0 & -1 & -1 \\ -1 & -1 & -3 \\ -3 & -1 & -1 \end{bmatrix}$

Now from equation (1)

$\begin{bmatrix} 0 & 1 & a \\ 1 & 2 & 3 \\ 3 & b & 1 \end{bmatrix} = |M| \begin{bmatrix} 0 & -1 & -1 \\ -1 & -1 & -3 \\ -3 & -1 & -1 \end{bmatrix}$

By comparison, $|M| = -2$

So $a = |M| (-1) = -2(-1) = 2$

and $b = |M| \times \frac{-1}{2} = 1$

(A) $a + b = 2 + 1 = 3$

(B) $(\text{adj } M)^{-1} + \text{adj } M^{-1} \dots \text{adj } A^{-1} = (\text{adj } A)^{-1}$
 $= 2\text{adj}(M^{-1}) \dots A \cdot \text{adj } A = |A| I_n$
 $= 2 \left(\frac{-M}{2} \right)$
 $= -M$

$\text{adj } A = A^{-1} |A|$

So $\text{adj } (M^{-1}) = (M^{-1})^{-1} |M^{-1}|$

$\text{adj } (M^{-1}) = M |M|^{-1}$

$\text{adj } (M^{-1}) = \frac{M}{|M|} = \frac{-M}{2}$

(C) $\therefore M = \begin{bmatrix} 0 & 1 & 2 \\ 1 & 2 & 3 \\ 3 & 1 & 1 \end{bmatrix}$

So, $\begin{bmatrix} 0 & 1 & 2 \\ 1 & 2 & 3 \\ 3 & 1 & 1 \end{bmatrix} \begin{bmatrix} \alpha \\ \beta \\ \gamma \end{bmatrix} = \begin{bmatrix} 1 \\ 2 \\ 3 \end{bmatrix}$

So, $\beta + 2\gamma = 1 \dots(2)$

$\alpha + 2\beta + 3\gamma = 2 \dots(3)$

$3\alpha + \beta + \gamma = 3 \dots(4)$

From (2), (3) and (4), we get

$$\alpha = 1, \beta = -1, \gamma = 1$$

So value of $\alpha - \beta + \gamma = 1 - (-1) + 1 = 3$

$$(D) |\text{adj}(M^2)| = |M^2|^2 = |M|^4 = |-2|^4 = 16$$

6. Let α and β be the roots of $x^2 - x - 1 = 0$, with $\alpha > \beta$. For all positive integers n , define

$$a_n = \frac{\alpha^n - \beta^n}{\alpha - \beta}, \quad n \geq 1,$$

$$b_1 = 1 \text{ and } b_n = a_{n-1} + a_{n+1}, \quad n \geq 2.$$

Then which of the following options is/are correct?

(A) $\sum_{n=1}^{\infty} \frac{a_n}{10^n} = \frac{10}{89}$

(B) $b_n = \alpha^n + \beta^n$ for all $n \geq 1$

(C) $a_1 + a_2 + a_3 + \dots + a_n = a_{n+2} - 1$ for all $n \geq 1$

(D) $\sum_{n=1}^{\infty} \frac{b_n}{10^n} = \frac{8}{89}$

Answer (A, B, C)

Sol. (A) $\sum_{n=1}^{\infty} \frac{a_n}{10^n} = \sum_{n=1}^{\infty} \frac{\alpha^n - \beta^n}{(\alpha - \beta)10^n}$

$$= \frac{1}{\alpha - \beta} \left[\sum_{n=1}^{\infty} \left(\frac{\alpha}{10} \right)^n - \sum_{n=1}^{\infty} \left(\frac{\beta}{10} \right)^n \right]$$

$$= \frac{1}{\alpha - \beta} \left[\frac{\frac{\alpha}{10}}{1 - \frac{\alpha}{10}} - \frac{\frac{\beta}{10}}{1 - \frac{\beta}{10}} \right]$$

$$= \frac{1}{\alpha - \beta} \left[\frac{\alpha}{10 - \alpha} - \frac{\beta}{10 - \beta} \right]$$

$$= \frac{1}{\alpha - \beta} \left[\frac{10\alpha - \alpha\beta - 10\beta + \alpha\beta}{100 - 10\beta - 10\alpha + \alpha\beta} \right]$$

$$= \frac{1}{\alpha - \beta} \left[\frac{10(\alpha - \beta)}{100 - 10 - 1} \right] = \frac{10}{89}$$

(B) $a_{n+1} = \frac{\alpha^{n+1} - \beta^{n+1}}{\alpha - \beta} = \alpha^n + \alpha^{n-1}\beta + \alpha^{n-2}\beta^2 + \dots + \alpha\beta^{n-1} + \beta^n$

$$\{\because \alpha\beta = -1\}$$

$$a_{n+1} = \alpha^n - (\alpha^{n-2} + \alpha^{n-3}\beta + \dots + \beta^{n-2}) + \beta^n$$

$$\Rightarrow a_{n+1} = \alpha^n + \beta^n - a_{n-1}$$

$$\Rightarrow a_{n-1} + a_{n+1} = \alpha^n + \beta^n$$

$$\Rightarrow b_n = \alpha^n + \beta^n$$

(C) $\because \alpha^2 = \alpha + 1$ and $\beta^2 = \beta + 1$

$$\alpha^{n+2} = \alpha^{n+1} + \alpha^n \text{ and } \beta^{n+2} = \beta^{n+1} + \beta^n$$

$$\alpha^{n+2} - \beta^{n+2} = (\alpha^{n+1} - \beta^{n+1}) + (\alpha^n - \beta^n)$$

$$a_{n+2} = a_{n+1} + a_n \quad \dots(i)$$

Similarly $a_{n+1} = a_n + a_{n-1} \quad \dots(ii)$

$$a_n = a_{n-1} + a_{n-2} \quad \dots(iii)$$

$$a_3 = a_2 + a_1$$

On adding $a_{n+2} = (a_1 + a_2 + a_3 + \dots + a_n) + a_2$ (Here $a_2 = \alpha + \beta = 1$)

$$a_{n+2} - 1 = a_1 + a_2 + a_3 + \dots + a_n$$

$$(D) \sum_{n=1}^{\infty} \frac{b_n}{10^n} = \sum_{n=1}^{\infty} \frac{\alpha^n + \beta^n}{10^n} = \sum_{n=1}^{\infty} \left(\frac{\alpha}{10}\right)^n + \sum_{n=1}^{\infty} \left(\frac{\beta}{10}\right)^n$$

$$= \frac{\frac{\alpha}{10}}{1 - \frac{\alpha}{10}} + \frac{\frac{\beta}{10}}{1 - \frac{\beta}{10}} \quad \because \left|\frac{\alpha}{10}\right| < 1$$

$$\left|\frac{\beta}{10}\right| < 1$$

$$= \frac{\alpha}{10 - \alpha} + \frac{\beta}{10 - \beta}$$

$$= \frac{10\alpha - \alpha\beta + 10\beta - \alpha\beta}{(10 - \alpha)(10 - \beta)}$$

$$= \frac{10(1) - 2(-1)}{100 - 10(\alpha + \beta) + \alpha\beta} = \frac{12}{89}$$

7. Let L_1 and L_2 denote the lines

$$\vec{r} = \hat{i} + \lambda(-\hat{i} + 2\hat{j} + 2\hat{k}), \lambda \in \mathbb{R} \text{ and}$$

$$\vec{r} = \mu(2\hat{i} - \hat{j} + 2\hat{k}), \mu \in \mathbb{R}$$

respectively. If L_3 is a line which is perpendicular to both L_1 and L_2 and cuts both of them, then which of the following options describe(s) L_3 ?

(A) $\vec{r} = \frac{1}{3}(2\hat{i} + \hat{k}) + t(2\hat{i} + 2\hat{j} - \hat{k}), t \in \mathbb{R}$

(B) $\vec{r} = \frac{2}{9}(4\hat{i} + \hat{j} + \hat{k}) + t(2\hat{i} + 2\hat{j} - \hat{k}), t \in \mathbb{R}$

(C) $\vec{r} = \frac{2}{9}(2\hat{i} - \hat{j} + 2\hat{k}) + t(2\hat{i} + 2\hat{j} - \hat{k}), t \in \mathbb{R}$

(D) $\vec{r} = t(2\hat{i} + 2\hat{j} - \hat{k}), t \in \mathbb{R}$

Answer (A, B, C)

Sol. $\therefore L_3$ is perpendicular to both L_1 and L_2 .

Then a vector along L_3 will be,

$$\begin{vmatrix} \hat{i} & \hat{j} & \hat{k} \\ -1 & 2 & 2 \\ 2 & -1 & 2 \end{vmatrix} = 3(2\hat{i} + 2\hat{j} - \hat{k})$$

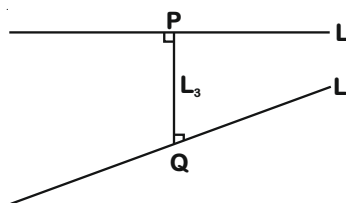

Consider a point on L_1 as $P(-\lambda + 1, 2\lambda, 2\lambda)$ and a point on L_2 as $Q(2\mu, -\mu, 2\mu)$

DR's of $L_3 < 2\mu + \lambda - 1, -\mu - 2\lambda, 2\mu - 2\lambda >$

Here $\frac{2\mu + \lambda - 1}{2} = \frac{-\mu - 2\lambda}{2} = \frac{2\mu - 2\lambda}{-1}$

$$\Rightarrow \lambda = \frac{1}{9} \quad \text{and} \quad \mu = \frac{2}{9}$$

$$P\left(\frac{8}{9}, \frac{2}{9}, \frac{2}{9}\right) \text{ and } Q\left(\frac{4}{9}, -\frac{2}{9}, \frac{4}{9}\right); \text{ mid-point of PQ is } R\left(\frac{2}{3}, 0, \frac{1}{3}\right)$$

Equation of $L_3: \vec{r} = \vec{a} + \lambda(2\hat{i} + 2\hat{j} - \hat{k})$, here \vec{a} is the position vector of any point on L_3 . Possible vector

$$\text{of } \vec{a} \text{ are } \left(\frac{8}{9}\hat{i} + \frac{2}{9}\hat{j} + \frac{2}{9}\hat{k}\right) \text{ or } \left(\frac{4}{9}\hat{i} - \frac{2}{9}\hat{j} + \frac{4}{9}\hat{k}\right) \text{ or } \left(\frac{2}{3}\hat{i} + \frac{1}{3}\hat{k}\right)$$

8. Define the collections $\{E_1, E_2, E_3, \dots\}$ of ellipses and $\{R_1, R_2, R_3, \dots\}$ of rectangles as follows:

$$E_1: \frac{x^2}{9} + \frac{y^2}{4} = 1;$$

R_1 : rectangle of largest area, with sides parallel to the axes, inscribed in E_1 ;

E_n : ellipse $\frac{x^2}{a_n^2} + \frac{y^2}{b_n^2} = 1$ of largest area inscribed in R_{n-1} , $n > 1$;

R_n : rectangle of largest area, with sides parallel to the axes, inscribed in E_n , $n > 1$.

Then which of the following options is/are correct ?

(A) The eccentricities of E_{18} and E_{19} are NOT equal

(B) The length of latus rectum of E_9 is $\frac{1}{6}$

(C) $\sum_{n=1}^N (\text{area of } R_n) < 24$, for each positive integer N

(D) The distance of a focus from the centre in E_9 is $\frac{\sqrt{5}}{32}$

Answer (B, C)

Sol. $E_1 = \frac{x^2}{a^2} + \frac{y^2}{b^2} = 1$ (Here $a = 3$ and $b = 2$)

Let a vertex of R_1 be $(a\cos\theta, b\sin\theta)$

$$\begin{aligned} \text{Area of } R_1 &= 2a\cos\theta \times 2b\sin\theta \\ &= 2ab\sin 2\theta \end{aligned}$$

Area of R_1 will be maximum if

$$\theta = \frac{\pi}{4}$$

So, maximum area of $R_1 = 2ab$

Now, ellipse E_2 will have semi-major axis $\frac{a}{\sqrt{2}}$ and semi-minor axis $\frac{b}{\sqrt{2}}$

$$E_2: \frac{x^2}{\left(\frac{a}{\sqrt{2}}\right)^2} + \frac{y^2}{\left(\frac{b}{\sqrt{2}}\right)^2} = 1; \text{ maximum area of } R_2 = 2\left(\frac{a}{\sqrt{2}}\right)\left(\frac{b}{\sqrt{2}}\right)$$

$$\text{Similarly } E_3: \frac{x^2}{\left(\frac{a}{(\sqrt{2})^2}\right)^2} + \frac{y^2}{\left(\frac{b}{(\sqrt{2})^2}\right)^2} = 1 \text{ and so on.}$$

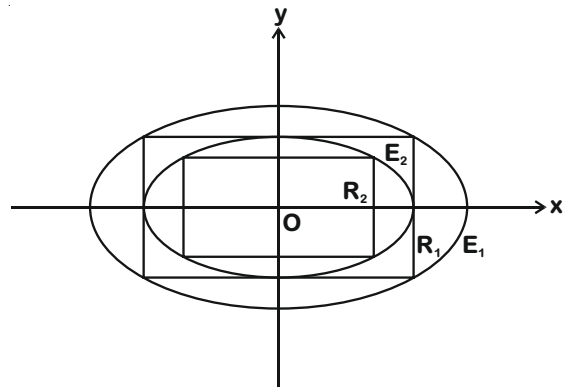

$$\text{So, } E_n : \frac{x^2}{\left(\frac{a}{(\sqrt{2})^{n-1}}\right)^2} + \frac{y^2}{\left(\frac{b}{(\sqrt{2})^{n-1}}\right)^2} = 1$$

$$\text{and maximum area of } R_n = 2 \left(\frac{a}{(\sqrt{2})^{n-1}}\right) \left(\frac{b}{(\sqrt{2})^{n-1}}\right)$$

- (A) All ellipse have same eccentricity because the ratio of semi-major axis and semi-minor axis is same for all ellipses.

$$e = \sqrt{1 - \frac{b_n^2}{a_n^2}} = \sqrt{1 - \frac{b^2}{a^2}} = \frac{\sqrt{5}}{3}$$

- (B) Length of latus rectum of $E_n = \frac{2b_n^2}{a_n} = \frac{2b^2}{a(\sqrt{2})^{n-1}}$

$$\text{Length of latus rectum of } E_9 = \frac{2 \times 4}{3 \times (\sqrt{2})^{9-1}} = \frac{1}{6}$$

- (C) $\sum_{n=1}^m$ area of rectangle $R_n < \text{area of } R_1 + \text{area of } R_2 + \dots + \infty$
- $$\sum_{n=1}^m \text{area of rectangle } R_n < 2ab + 2 \left(\frac{a}{\sqrt{2}}\right) \left(\frac{b}{\sqrt{2}}\right) + 2 \left(\frac{a}{(\sqrt{2})^2}\right) \left(\frac{b}{(\sqrt{2})^2}\right) + \dots + \infty$$
- $$\sum_{n=1}^m \text{area of rectangle } R_n < 2ab \left[1 + \frac{1}{2} + \frac{1}{2^2} + \dots + \infty \right]$$
- $$\sum_{n=1}^m \text{area of rectangle } R_n < 12 \left[\frac{1}{1 - \frac{1}{2}} \right]$$
- $$\sum_{n=1}^m \text{area of rectangle } R_n < 24$$

- (D) Distance between focus and centre of $E_9 = a_9 \cdot e$

$$= \frac{a}{(\sqrt{2})^8} \cdot e = \frac{3}{2^4} \cdot \frac{\sqrt{5}}{3} = \frac{\sqrt{5}}{16}$$

SECTION - 3 (Maximum Marks : 18)

- This section contains SIX (06) questions. The answer to each question is a NUMERICAL VALUE.
- For each question, enter the correct numerical value of the answer using the mouse and the on-screen virtual numeric keypad in the place designated to enter the answer. If the numerical value has more than two decimal places, truncate/round-off the value to TWO decimal places.
- Answer to each question will be evaluated according to the following marking scheme:

Full Marks : +3 If ONLY the correct numerical value is entered.

Zero Marks : 0 In all other cases.

1. Three lines are given by

$$\vec{r} = \lambda \hat{i}, \lambda \in \mathbb{R}$$

$$\vec{r} = \mu(\hat{i} + \hat{j}), \mu \in \mathbb{R} \text{ and}$$

$$\vec{r} = \nu(\hat{i} + \hat{j} + \hat{k}), \nu \in \mathbb{R}.$$

Let the lines cut the plane $x + y + z = 1$ at the points A, B and C respectively. If the area of the triangle ABC is Δ then the value of $(6\Delta)^2$ equals _____

Answer (0.75)

Sol. Finding point A

$\vec{r} = \lambda \hat{i}$ and $x + y + z = 1$, we get

$$\lambda + 0 + 0 = 1 \Rightarrow \lambda = 1 \Rightarrow A = (1, 0, 0)$$

Similarly for point B

$\vec{r} = \mu(\hat{i} + \hat{j})$ and $x + y + z = 1$

$$\text{We get } \mu + \mu + 0 = 1 \Rightarrow \mu = \frac{1}{2} \Rightarrow B\left(\frac{1}{2}, \frac{1}{2}, 0\right)$$

$$\text{and for point C } \vec{r} = \nu(\hat{i} + \hat{j} + \hat{k}) \Rightarrow \nu = \frac{1}{3} \Rightarrow C\left(\frac{1}{3}, \frac{1}{3}, \frac{1}{3}\right)$$

Area of triangle ABC

$$\Delta = \frac{1}{2} |\overline{AB} \times \overline{AC}|$$

$$\left(\text{i.e. } \overline{AB} = -\frac{1}{2}\hat{i} + \frac{1}{2}\hat{j} \text{ and } \overline{AC} = -\frac{2}{3}\hat{i} + \frac{1}{3}\hat{j} + \frac{1}{3}\hat{k}\right)$$

$$\begin{aligned} \Rightarrow \Delta &= \frac{1}{2} \left| \left(-\frac{1}{2}\hat{i} + \frac{1}{2}\hat{j}\right) \times \left(-\frac{2}{3}\hat{i} + \frac{1}{3}\hat{j} + \frac{1}{3}\hat{k}\right) \right| \\ &= \frac{\sqrt{3}}{12} \Rightarrow (6\Delta)^2 = \left(\frac{6\sqrt{3}}{12}\right)^2 = \frac{3}{4} = 0.75 \end{aligned}$$

2. If $I = \frac{2}{\pi} \int_{-\pi/4}^{\pi/4} \frac{dx}{(1 + e^{\sin x})(2 - \cos 2x)}$; then $27I^2$ equals _____

Answer (4.00)

Sol. $I = \frac{2}{\pi} \int_{-\pi/4}^{\pi/4} \frac{dx}{(1 + e^{\sin x})(2 - \cos 2x)}$

$$I = \frac{2}{\pi} \int_{-\pi/4}^{\pi/4} \frac{dx}{(1 + e^{-\sin x})(2 - \cos 2x)} = \frac{2}{\pi} \int_{-\pi/4}^{\pi/4} \frac{e^{\sin x} dx}{(1 + e^{\sin x})(2 - \cos 2x)}$$

$$2I = \frac{2}{\pi} \int_{-\pi/4}^{\pi/4} \frac{dx}{(2 - \cos 2x)} \Rightarrow I = \frac{2}{\pi} \int_0^{\pi/4} \frac{dx}{(2 - \cos 2x)}$$

$$I = \frac{2}{\pi} \int_0^{\pi/4} \frac{dx}{3 - 2\cos^2 x} = \frac{2}{\pi} \int_0^{\pi/4} \frac{\sec^2 x dx}{1 + 3\tan^2 x}$$

$$\text{Put } \sqrt{3} \tan x = t \Rightarrow \sec^2 x dx = \frac{dt}{\sqrt{3}}$$

$$I = \frac{2}{\pi} \times \frac{1}{\sqrt{3}} \int_0^{\sqrt{3}} \frac{dt}{1+t^2} = \frac{2}{\sqrt{3}\pi} \left[\tan^{-1} t \right]_0^{\sqrt{3}} = \frac{2}{\sqrt{3}\pi} \times \frac{\pi}{3} = \frac{2}{3\sqrt{3}}$$

$$\Rightarrow 27I^2 = 27 \times \frac{4}{9 \times 3} = 4.00$$

3. Let the point B be the reflection of the point A(2, 3) with respect to the line $8x - 6y - 23 = 0$. Let Γ_A and Γ_B be circles of radii 2 and 1 with centres A and B respectively. Let T be a common tangent to the circles Γ_A and Γ_B such that both the circles are on the same side of T. If C is the point of intersection of T and the line passing through A and B, then the length of the line segment AC is _____

Answer (10.00)

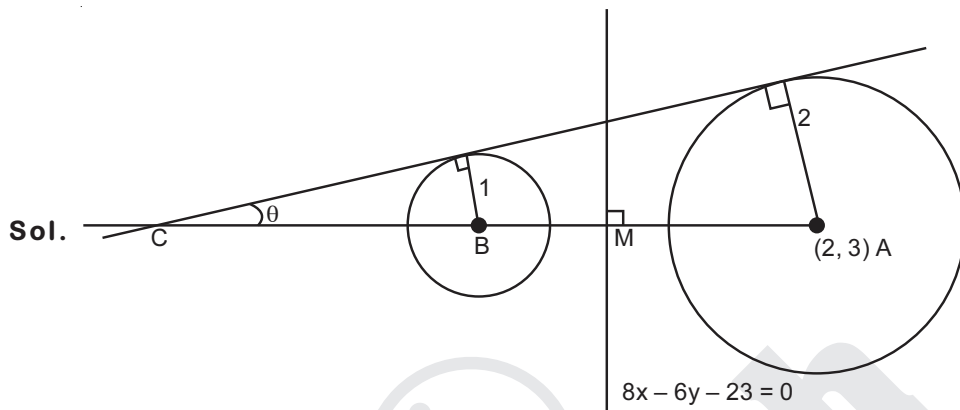

$$BM = AM = \frac{|8 \times 2 - 6 \times 3 - 23|}{\sqrt{64 + 36}} = \frac{25}{10} = \frac{5}{2}$$

$$\Rightarrow AB = 5$$

$$\sin \theta = \frac{1}{CB} = \frac{2}{CB + AB} \Rightarrow \frac{1}{CB} = \frac{2}{CB + 5} \Rightarrow CB = 5$$

$$\Rightarrow AC = 10.00$$

4. Let AP (a;d) denote the set of all the terms of an infinite arithmetic progression with first term a and common difference $d > 0$. If

$$AP(1;3) \cap AP(2;5) \cap AP(3;7) = AP(a;d)$$

then $a + d$ equals _____

Answer (157.00)

Sol. $T_{(1, m)} = T_{(2, n)} = T_{(3, r)}$

$T_{(1, m)}$ is m^{th} term of 1st series, $T_{(2, n)}$ is n^{th} term of second series and $T_{(3, r)}$ is r^{th} term of third series

$$\Rightarrow 1 + (m - 1)3 = 2 + (n - 1)5 = 3 + (r - 1)7$$

For common terms of 1st and 2nd series

$$m = \frac{5n - 1}{3} \Rightarrow n = 2, 5, 11, \dots$$

For common terms of 2nd and 3rd series

$$r = \frac{5n + 1}{7} \Rightarrow n = 4, 11, \dots$$

\Rightarrow First common term of 1st, 2nd and 3rd series (when $n = 11$)

$$a = 2 + (11 - 1)5 = 52$$

$$d = \text{L.C.M.}(3, 5, 7) = 105$$

$$\Rightarrow a + d = 157.00$$

5. Let S be the sample space of all 3×3 matrices with entries from the set $\{0, 1\}$. Let the events E_1 and E_2 be given by
 $E_1 = \{A \in S : \det A = 0\}$ and
 $E_2 = \{A \in S : \text{sum of entries of } A \text{ is } 7\}$.
 If a matrix is chosen at random from S , then the conditional probability $P(E_1|E_2)$ equals ____

Answer (0.50)

Sol. For sum 7 we need seven 1s and two zeroes

$$\therefore \text{Number of different possible matrices} = \frac{9!}{7!2!} = 36 = n(E_2)$$

For $|A| = 0$ both zeroes must be in same row/column

\therefore Number of matrices such that their determinant is

$$\text{Zero} = 6 \times \frac{3!}{2!} = 18 = n(E_1 \cap E_2)$$

$$\begin{aligned} \therefore \text{Required probability} &= P\left(\frac{E_1}{E_2}\right) = \frac{n(E_1 \cap E_2)}{n(E_2)} \\ &= \frac{18}{36} = \frac{1}{2} \end{aligned}$$

6. Let $\omega \neq 1$ be a cube root of unity. Then the minimum of the set $\{|a + b\omega + c\omega^2|^2 : a, b, c \text{ distinct non-zero integers}\}$ equals ____

Answer (3.00)

$$\begin{aligned} \text{Sol. } |a + b\omega + c\omega^2|^2 &= (a + b\omega + c\omega^2)(\overline{a + b\omega + c\omega^2}) \\ &= (a + b\omega + c\omega^2)(a + b\omega^2 + c\omega) \\ &= a^2 + b^2 + c^2 - ab - bc - ca \\ &= \frac{1}{2}\{(a-b)^2 + (b-c)^2 + (c-a)^2\} \end{aligned}$$

- \therefore a, b, c are distinct non-zero integers.
 \therefore For minimum value $a = 1, b = 2$ and $c = 3$.

$$\therefore \text{Minimum value} = \frac{1}{2}\{1+1+4\} = 3$$

