

DATE : 20/05/2019



# Aakash

Medical | IIT-JEE | Foundations

(Divisions of Aakash Educational Services Limited)

Regd. Office : Aakash Tower, 8, Pusa Road, New Delhi-110005. Ph.: 011-47623456

Test Booklet Code

**E1**

LOCHAN

Time : 3 hrs.

## Answers & Solutions

Max. Marks : 720

*for*

## NEET (UG) - 2019

### Important Instructions :

1. The test is of **3 hours** duration and Test Booklet contains **180** questions. Each question carries **4** marks. For each correct response, the candidate will get **4** marks. For each incorrect response, **one mark** will be deducted from the total scores. The maximum marks are **720**.
2. Use **Blue / Black Ball point Pen only** for writing particulars on this page/markings responses.
3. Rough work is to be done on the space provided for this purpose in the Test Booklet only.
4. On completion of the test, the candidate must handover the Answer Sheet to the Invigilator before leaving the Room / Hall. *The candidates are allowed to take away this Test Booklet with them.*
5. The CODE for this Booklet is **E1**.
6. The candidates should ensure that the Answer Sheet is not folded. Do not make any stray marks on the Answer Sheet. Do not write your Roll No. anywhere else except in the specified space in the Test Booklet/Answer Sheet.
7. Each candidate must show on demand his/her Admission Card to the Invigilator.
8. No candidate, without special permission of the Superintendent or Invigilator, would leave his/her seat.
9. Use of Electronic/Manual Calculator is prohibited.
10. The candidates are governed by all Rules and Regulations of the examination with regard to their conduct in the Examination Hall. All cases of unfair means will be dealt with as per Rules and Regulations of this examination.
11. No part of the Test Booklet and Answer Sheet shall be detached under any circumstances.
12. The candidates will write the Correct Test Booklet Code as given in the Test Booklet / Answer Sheet in the Attendance Sheet.

1. Which is the most common type of embryo sac in angiosperms?
- (1) Monosporic with three sequential mitotic divisions
  - (2) Monosporic with two sequential mitotic divisions
  - (3) Bisporic with two sequential mitotic divisions
  - (4) Tetrasporic with one mitotic stage of divisions

**Answer (1)**

**Sol.** Monosporic embryo sac is the most common type of embryo sac in flowering plants which develops after one meiosis and three sequential mitosis in megaspore mother cell.

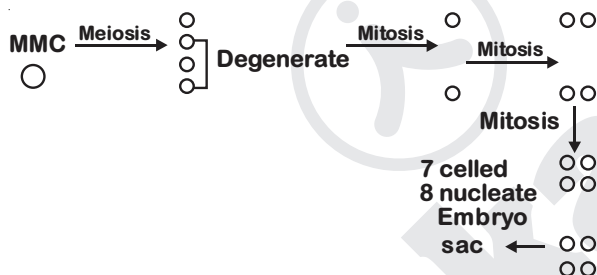

2. From the following, identify the *correct combination* of salient features of Genetic Code -
- (1) Degenerate, Overlapping, Commaless
  - (2) Universal, Ambiguous, Degenerate
  - (3) Degenerate, Non-overlapping, Non-ambiguous
  - (4) Universal, Non-ambiguous, Overlapping

**Answer (3)**

**Sol.** Genetic code is universal, unambiguous, non overlapping and degenerate in nature.

3. Which scientist experimentally proved that DNA is the sole genetic material in bacteriophage?
- (1) Messelson and Stahl
  - (2) Hershey and Chase
  - (3) Jacob and Monod
  - (4) Beadle and Tatum

**Answer (2)**

**Sol.** A Hershey and M. Chase using radiolabelled sulphur and phosphorus in bacteriophage, proved that DNA is genetic material.

4. In the process of transcription in Eukaryotes, the RNA polymerase I transcribes -
- (1) tRNA, 5 srRNA and snRNAs
  - (2) rRNAs – 28 S, 18 S and 5.8 S
  - (3) Precursor of mRNA, hnRNA
  - (4) mRNA with additional processing, capping and tailing

**Answer (2)**

**Sol.** During transcription in eukaryotes, RNA polymerase I transcribes 5.8S, 18S and 28S rRNA.

5. In which genetic condition, each cell in the affected person, has three sex chromosomes XXY?
- (1) Klinefelter's Syndrome
  - (2) Phenylketonuria
  - (3) Turner's Syndrome
  - (4) Thalassemia

**Answer (1)**

**Sol.** Klinefelter's syndrome is caused due to presence of an additional copy of X-chromosome resulting into 44 + XXY type chromosome complement.

6. What initiation and termination factors are involved in transcription in Eukaryotes?
- (1)  $\alpha$  and  $\beta$ , respectively
  - (2)  $\beta$  and  $\gamma$ , respectively
  - (3)  $\alpha$  and  $\sigma$ , respectively
  - (4)  $\sigma$  and  $\rho$ , respectively

**Answer (4\*)**

7. Which of the following statements is correct about the origin and evolution of men?
- (1) The *Dryopithecus* and *Ramapithecus* primates existing 15 million years ago, walked like men.
  - (2) *Homo habilis* probably ate meat.
  - (3) Neanderthal men lived in Asia between 1,00,000 and 40,000 years back.
  - (4) Agriculture came around 50,000 years back.

**Answer (3)**

**Sol.** – Agriculture came around 10,000 years back and human settlements started.

- *Homo habilis* probably did not eat meat.
- The *Dryopithecus* and *Ramapithecus* primates existing 15 mya. They are hairy and walked like gorillas and chimpanzees.

8. The production of gametes by the parents, the formation of zygotes, the  $F_1$  and  $F_2$  plants, can be understood using
- (1) A pyramid diagram
  - (2) Punnett square
  - (3) Wenn diagram
  - (4) Pie diagram

**Answer (2)**

**Sol.** With the help of Punnett square the production of gametes, the formation of zygotes and the  $F_1$  and  $F_2$  plants can be understood.

9. A selectable marker is used to :
- (1) identify the gene for a desired trait in an alien organism
  - (2) select a suitable vector for transformation in a specific crop
  - (3) mark a gene on a chromosome for isolation using restriction enzyme
  - (4) help in eliminating the non-transformants, so that the transformants can be regenerated

**Answer (4)**

**Sol.** Selectable markers help in identification and elimination of non-transformants whilst permitting selective growth of transformants.

10. Western Ghats have a large number of plant and animal species that are not found anywhere else. Which of the following terms will you use to notify such species?
- (1) Vulnerable
  - (2) Threatened
  - (3) Keystone
  - (4) Endemic

**Answer (4)**

**Sol.** Endemic species are those species that are confined to a particular region only and not found anywhere else.

11. Which of the following statements about ozone is correct?
- (1) Stratospheric ozone is 'bad'.
  - (2) Tropospheric ozone is 'good'.
  - (3) Stratospheric ozone protects us from UV radiations.
  - (4) Tropospheric ozone protects us from UV radiations.

**Answer (3)**

**Sol.** Ozone, in our atmosphere is found in two layers

1. Stratosphere – good ozone, protects us from UV radiations
2. Troposphere – bad ozone, considered as a pollutant.

12. Exploration of molecular, genetic and species level diversity for novel products of economic importance is known as :

- (1) Bioenergetics
- (2) Bioremediation
- (3) Bioprospecting
- (4) Biopiracy

**Answer (3)**

**Sol.** Bioprospecting refers to exploring molecular, genetic and species level diversity for products of economic importance.

13. Which of the following is an innovative remedy for plastic waste?
- (1) Burying 500 m deep below soil surface
  - (2) Polyblend
  - (3) Electrostatic precipitator
  - (4) Burning in the absence of oxygen

**Answer (2)**

**Sol.** Polyblend is an innovative remedy of plastic waste. Polyblend is fine powder of recycled plastic waste that after mixing with bitumen, used to lay roads.

14. Between which among the following, the relationship is *not* an example of commensalism?
- (1) Cattle Egret and grazing cattle
  - (2) Sea Anemone and Clown fish
  - (3) Female wasp and fig species
  - (4) Orchid and the tree on which it grows

**Answer (3)**

**Sol.** Female wasp and fig species show mutualism. While orchid on trees on which it grows, cattle egret and grazing cattle, and sea anemone and clown fish show commensalism.

15. If an agricultural field is liberally irrigated for a prolonged period of time, it is likely to face a problem of :
- (1) Alkalinity
  - (2) Acidity
  - (3) Salinity
  - (4) Metal toxicity

**Answer (3)**

**Sol.** Irrigation of agricultural field for a prolonged time without proper drainage leads to waterlogging in the soil. Waterlogging draws salt to the surface of the soil and causes salinity.

16. Match the column I with column II.

Column I	Column II
(a) Golgi apparatus	(i) Synthesis of protein
(b) Lysosomes	(ii) Trap waste and excretory products
(c) Vacuoles	(iii) Formation of glycoproteins and glycolipids
(d) Ribosomes	(iv) Digesting biomolecules

Choose the right match from options given below :

- (1) (a)-(iv), (b)-(iii), (c)-(i), (d)-(ii)
- (2) (a)-(iii), (b)-(ii), (c)-(iv), (d)-(i)
- (3) (a)-(i), (b)-(ii), (c)-(iv), (d)-(iii)
- (4) (a)-(iii), (b)-(iv), (c)-(ii), (d)-(i)

**Answer (4)**

**Sol.** (a) Golgi apparatus (iii) Formation of glycoproteins and glycolipids

(b) Lysosomes (iv) Digesting biomolecules

(c) Vacuoles (ii) Trap waste and excretory products

(d) Ribosomes (i) Synthesis of protein

17. Prosthetic groups differ from co-enzymes in that-

- (1) They (prosthetic groups) are tightly bound to apoenzymes
- (2) Their association with apoenzymes is transient
- (3) They can serve as co-factors in a number of enzyme - catalyzed reactions
- (4) They require metal ions for their activity

**Answer (1)**

**Sol.** Prosthetic groups are organic compounds that are tightly bound to the apoenzyme but coenzymes are associated with the apoenzyme last for a short period of time *i.e.* transiently.

18. Crossing over takes place between which chromatids and in which stage of the cell cycle ?

- (1) Non-sister chromatids of homologous chromosomes at Pachytene stage of prophase I
- (2) Non-sister chromatids of homologous chromosomes at Zygotene stage of prophase I
- (3) Non-sister chromatids of non-homologous chromosomes at Pachytene stage of prophase I
- (4) Non-sister chromatids of non-homologous chromosomes at Zygotene stage of prophase I

**Answer (1)**

**Sol.** Crossing over takes place between non-sister chromatids of homologous chromosomes at pachytene stage

19. "Ramachandran plot" is used to confirm the structure of

- |              |                       |
|--------------|-----------------------|
| (1) Proteins | (2) Triacylglycerides |
| (3) DNA      | (4) RNA               |

**Answer (1)**

**Sol.** "Ramachandran plot" is used to confirm the structure of proteins.

A Ramachandran plot, is a way to visualize energetically allowed regions for backbone dihedral angles  $\psi$  against  $\phi$  of amino acid residues to protein structure.

20. Which of the following is **not** a feature of active transport of solutes in plants ?

- (1) Non-selective
- (2) Occurs through membranes
- (3) Requires ATP
- (4) Occurs against concentration gradient

**Answer (1)**

**Sol.** Active transport is uphill transport which requires membrane proteins and ATP. It is highly selective.

21. Which of the following bacteria reduce nitrate in soil into nitrogen ?

- |                         |                         |
|-------------------------|-------------------------|
| (1) <i>Nitrococcus</i>  | (2) <i>Thiobacillus</i> |
| (3) <i>Nitrosomonas</i> | (4) <i>Nitrobacter</i>  |

**Answer (2)**

Sol. Nitrates (soil)  $\xrightarrow{\text{Denitrification}}$  Nitrogen  
 $\downarrow$

*Pseudomonas denitrificans* &  
*Thiobacillus denitrificans*

22. What will be the direction of flow of water when a plant cell is placed in a hypotonic solution ?

- (1) Water will flow out of the cell
- (2) Water will flow into the cell
- (3) No flow of water in any direction
- (4) Water will flow in both directions

Answer (2)

Sol. When a plant cell is placed in hypotonic solution water will flow into the cell as water moves from high water potential to low water potential.

23. Where is the respiratory electron transport system (ETS) located in plants ?

- (1) Outer mitochondrial membrane
- (2) Inner mitochondrial membrane
- (3) Intermembrane space
- (4) Mitochondrial matrix

Answer (2)

Sol. Electron transport system is located in inner mitochondrial membrane.

24. Which of the following statements about methanogens is *not correct* ?

- (1) They are found in the rumen of cattle and their excreta.
- (2) They grow aerobically and breakdown cellulose-rich food.
- (3) They produce methane gas.
- (4) They can be used to produce biogas.

Answer (2)

Sol. Methanogens are anaerobic chemoautotrophs.

They grow in anaerobic condition and breakdown cellulose rich food.

25. In mung bean, resistance to yellow mosaic, virus and powdery mildew were brought about by :

- (1) Biofortification
- (2) Tissue culture
- (3) Hybridization and selection
- (4) Mutation breeding

Answer (4)

Sol. In mung bean, resistance to yellow mosaic virus and powdery mildew were induced by mutations.

26. Coca alkaloid or cocaine is obtained from :

- (1) *Atropa belladonna*
- (2) *Erythroxylum coca*
- (3) *Datura*
- (4) *Papaver somniferum*

Answer (2)

Sol. Coca alkaloids or cocaine is obtained from, *Erythroxylum coca*, a native to South America.

27. Among the following pairs of microbes, which pair has both the microbes that can be used as biofertilizers?

- (1) *Rhizobium* and *Rhizopus*
- (2) *Cyanobacteria* and *Rhizobium*
- (3) *Aspergillus* and *Cyanobacteria*
- (4) *Aspergillus* and *Rhizopus*

Answer (2)

Sol. Cyanobacteria like *Anabaena*, *Nostoc* etc. and *Rhizobium* are able to fix atmospheric nitrogen and used as biofertilizers.

*Rhizopus* and *Aspergillus* are used in production of other compounds of human benefit.

28. Given below are four statements pertaining to separation of DNA fragments using Gel electrophoresis. Identify the incorrect statements.

- (a) DNA is negatively charged molecule and so it is loaded on gel towards the Anode terminal.
- (b) DNA fragments travel along the surface of the gel whose concentration does not affect movement of DNA.
- (c) Smaller the size of DNA fragment, larger is the distance it travels through it.
- (d) Pure DNA can be visualized directly by exposing to UV radiation.

Choose correct answer from the options given below :

- (1) (a), (b) and (c)
- (2) (b), (c) and (d)
- (3) (a), (b) and (d)
- (4) (a), (c) and (d)

Answer (3)

- Sol.** • DNA fragments are negatively charged molecules. Separated by forcing them to move towards positive electrode *i.e.* anode.
- Increasing the concentration of a gel reduces the migration speed of DNA.
  - Smaller the fragment size, farther it moves from the point of loading *i.e.* the well.
  - DNA fragment can only be visualised under UV light after staining with ethidium bromide and not directly.

29. An enzyme catalysing the removal of nucleotides from ends of DNA is :
- (1) Endonuclease      (2) Exonuclease  
(3) Protease          (4) DNA ligase

**Answer (2)**

**Sol.** Restriction enzymes belong to a larger class of enzymes called Nucleases.

Nucleases are of two different kinds :

- (1) Exonucleases which remove nucleotides from the end of a DNA molecule
- (2) Endonucleases, which break internal phosphodiester bonds at palindromic sites that are highly specific
- (3) DNA ligase helps in ligating/joining DNA fragments
30. In RNAi, the genes are silenced using :
- (1) ss - DNA          (2) ss - RNA  
(3) ds - DNA          (4) ds - RNA

**Answer (4)**

**Sol.** RNAi involves silencing of a specific mRNA and therefore the expression of a gene by formation of a dsRNA molecule. The dsRNA which is formed by binding of a complementary RNA (anti-sense RNA) molecule to original mRNA thereby preventing translation of the original mRNA.

31. Which of the following is against the rules of ICBN?
- (1) Every species should have a generic name and a specific epithet.
- (2) Scientific names are in Latin and should be italicized.
- (3) Generic and specific names should be written starting with small letters.
- (4) Hand written scientific names should be underlined.

**Answer (3)**

**Sol.** The first word denoting the genus starts with a capital letter while the specific epithet starts with a small letter.

32. Mad cow disease in cattle is caused by an organism which has :
- (1) abnormally folded protein  
(2) free RNA without protein coat  
(3) free DNA without protein coat  
(4) inert crystalline structure

**Answer (1)**

**Sol.** Mad cow disease in cattle is caused by prions. Prions are disease causing agents having abnormally folded proteins.

33. Which of the following statements is correct?
- (1) Algal component of lichens is called mycobiont
- (2) Fungal component of lichens is called phycobiont.
- (3) Lichens are not good pollution indicators.
- (4) Lichens do not grow in polluted areas.

**Answer (4)**

**Sol.** Lichens are very good pollution indicators. They do not grow in polluted areas.

34. Match the organisms in column I with habitats in column II.

Column-I	Column-II
(a) Halophiles	(i) Hot springs
(b) Thermoacidophiles	(ii) Aquatic environment
(c) Methanogens	(iii) Guts of ruminants
(d) Cyanobacteria	(iv) Salty areas

Select the correct answer from the options given below :

- (1) (a)-(i), (b)-(ii), (c)-(iii), (d)-(iv)  
(2) (a)-(iii), (b)-(iv), (c)-(ii), (d)-(i)  
(3) (a)-(ii), (b)-(iv), (c)-(iii), (d)-(i)  
(4) (a)-(iv), (b)-(i), (c)-(iii), (d)-(ii)

**Answer (4)**

- Sol.** • Halophiles live in salty areas
- Thermoacidophiles are present in hot springs
  - Methanogens are present in gut of several ruminants
  - Cyanobacteria can be present in freshwater/ marine or terrestrial habitat

35. In the dicot root the vascular cambium originates from :
- (1) Cortical region
  - (2) Parenchyma between endodermis and pericycle
  - (3) Intrafascicular and interfascicular tissue in a ring
  - (4) Tissue located below the phloem bundles and a portion of pericycle tissue above protoxylem.

**Answer (4)**

**Sol.** Vascular cambium is a secondary meristematic tissue, in dicot roots. It is originated from tissue located below the phloem bundles and a portion of pericycle tissue above the protoxylem.

36. Which of the following shows whorled phyllotaxy?
- (1) China rose
  - (2) *Alstonia*
  - (3) *Calotropis*
  - (4) Mustard

**Answer (2)**

**Sol.** In whorled phyllotaxy, more than two leaves arise at each node and form a whorl or a circle.

*Alstonia* shows whorled phyllotaxy.

37. Regeneration of damaged growing grass following grazing is largely due to :
- (1) Apical meristem
  - (2) Intercalary meristem
  - (3) Secondary meristem
  - (4) Lateral meristem

**Answer (2)**

**Sol.** Intercalary meristems are found in grasses, where they help to regenerate the parts removed by the grazing herbivores.

38. Bicarpellary ovary with obliquely placed septum is seen in :
- (1) *Aloe*
  - (2) *Solanum*
  - (3) *Sesbania*
  - (4) *Brassica*

**Answer (2)**

**Sol.** Bicarpellary ovary with obliquely placed septum is seen in the members of family *Solanaceae* eg. *Solanum*

39. In Hatch and Slack pathway, the primary CO<sub>2</sub> acceptor is
- (1) Phosphoglyceric acid
  - (2) Phosphoenol pyruvate
  - (3) Rubisco
  - (4) Oxaloacetic acid

**Answer (2)**

**Sol.** PEP (Phosphoenol pyruvate) is the primary CO<sub>2</sub> acceptor in C<sub>4</sub> or Hatch & Slack pathway.

40. Removal of shoot tips is a very useful technique to boost the production of tea-leaves. This is because :
- (1) Auxins prevent leaf drop at early stages.
  - (2) Effect of auxins is removed and growth of lateral buds is enhanced.
  - (3) Gibberellins delay senescence of leaves.
  - (4) Gibberellins prevent bolting and are inactivated.

**Answer (2)**

**Sol.** Auxin shows apical dominance. Removal of auxin by removal of shoot tips prevents the apical dominance and promotes the growth of lateral buds which is a very useful in tea leaves production.

41. One scientist cultured *Cladophora* in a suspension of *Azotobacter* and illuminated the culture by splitting light through a prism. He observed that bacteria accumulated mainly in the region of :
- (1) Indigo and green light
  - (2) Orange and yellow light
  - (3) Blue and red light
  - (4) Violet and green light

**Answer (3)**

**Sol.** *Azotobacter* is aerobic bacteria.

*Cladophora* is green alga.

T.W. Engelmann split light into its spectral components and detected that aerobic bacteria accumulated mainly in the region of blue and red light of the split spectrum.

42. In order to increase the yield of sugarcane crop, which of the following plant growth regulators should be sprayed?
- (1) Auxins
  - (2) Gibberellins
  - (3) Cytokinins
  - (4) Ethylene

**Answer (2)**

**Sol.** Gibberellins shows bolting when gibberellin is sprayed on sugarcane crop, the length of the stem increases.

43. What type of pollination takes place in *Vallisneria*?

- (1) Flowers emerge above surface of water and pollination occurs by insects.
- (2) Flowers emerge above water surface and pollen is carried by wind.
- (3) Male flowers are carried by water currents to female flowers at surface of water.
- (4) Pollination occurs in submerged condition by water.

**Answer (3)**

**Sol.** *Vallisneria* shows epihydrophyly.

Male flowers after breakage float on the surface of water and reach the female flowers.

44. In which one of the following, both autogamy and geitonogamy are prevented?

- |            |            |
|------------|------------|
| (1) Papaya | (2) Castor |
| (3) Maize  | (4) Wheat  |

**Answer (1)**

**Sol.** Papaya is a dioecious plant in which male and female flowers are produced on two separate plants. Hence it prevents both autogamy as well as geitonogamy.

**Castor and Maize :** Monoecious and unisexual

**Wheat :** Monoecious and bisexual

45. Match the placental types (column-I) with their examples (column-II).

Column-I	Column-II
(a) Basal	(i) Mustard
(b) Axile	(ii) China rose
(c) Parietal	(iii) Dianthus
(d) Free central	(iv) Sunflower

Choose the correct answer from the following options :

- (1) (a)-(i), (b)-(ii), (c)-(iii), (d)-(iv)
- (2) (a)-(iv), (b)-(ii), (c)-(i), (d)-(iii)
- (3) (a)-(iii), (b)-(iv), (c)-(i), (d)-(ii)
- (4) (a)-(ii), (b)-(iii), (c)-(iv), (d)-(i)

**Answer (2)**

**Sol.** Basal : Sunflower  
Axile : China rose  
Parietal : Mustard  
Free central : *Dianthus*

46. Select the correct sequence of events.

- (1) Gametogenesis → Gamete transfer → Syngamy → Zygote → Cell division → (Cleavage) → Organogenesis → Cell differentiation.
- (2) Gametogenesis → Syngamy → Gamete transfer → Zygote → Cell division (Cleavage) → Cell differentiation → Organogenesis.
- (3) Gametogenesis → Gamete transfer → Syngamy → Zygote → Cell differentiation → Cell division (Cleavage) → Organogenesis.
- (4) Gametogenesis → Gamete transfer → Syngamy → Zygote → Cell division (Cleavage) → Cell differentiation → Organogenesis.

**Answer (4)**

**Sol.** Gametogenesis → Gamete transfer → Syngamy → Zygote → Cell division (Cleavage) → Cell differentiation → Organogenesis  
⇒ Gametogenesis → Formation of Gametes  
⇒ Gamete transfer → Insemination  
⇒ Syngamy → Fusion of gametes and leading to formation of gametes  
⇒ Cleavage → Repeated cell division.  
⇒ Cell differentiation → Specialization of cell to perform specific function.  
⇒ Organogenesis → Formation of organ

47. Which of the following hormones is responsible for both the milk ejection reflex and the foetal ejection reflex?

- |               |              |
|---------------|--------------|
| (1) Prolactin | (2) Oxytocin |
| (3) Relaxin   | (4) Estrogen |

**Answer (2)**

**Sol.** Foetal ejection reflex triggers release of oxytocin from the maternal anterior pituitary gland. Oxytocin acts on the uterine muscles and causes stronger uterine contractions.

Milk ejection reflex is caused by combined neurogenic and hormonal reflexes that involve release of oxytocin from posterior pituitary gland.

48. No new follicles develop in the luteal phase of the menstrual cycle because:
- (1) FSH levels are high in the luteal phase.
  - (2) LH levels are high in the luteal phase.
  - (3) Both FSH and LH levels are low in the luteal phase.
  - (4) Follicles do not remain in the ovary after ovulation.

**Answer (3)**

**Sol.** Ovulation is followed by the luteal phase during which the corpus luteum secretes estrogen and progesterone that exerts negative feedback on hypothalamus which in turn inhibits the release of FSH and LH. This prevents the development of new follicles during the luteal phase.

49. In Australia, marsupials and placental mammals have evolved to share many similar characteristics. This type of evolution may be referred to as
- (1) Divergent Evolution
  - (2) Cyclical Evolution
  - (3) Convergent Evolution
  - (4) Adaptive Radiation

**Answer (3)**

**Sol.** In Australia, marsupials and placental mammals have evolved to share many similar characteristics. This type of evolution may be referred to as convergent evolution.

Many placental mammals resemble the marsupial mammals not only in structure but also in leading similar ways of life. These similarities in these two different types of mammals (Marsupials and placentals) w.r.t. ancestors are due to living in the similar ecological niches. Hence, when two different types of organisms converge towards functional similarity one can conclude that convergent evolution has occurred

50. Match the items of Column-I with Column-II :

Column-I	Column-II
(a) XX-XO method of Sex Determination	(i) Turner's Syndrome
(b) XX-XY method of Sex Determination	(ii) Female Heterogametic
(c) Karyotype-45	(iii) Grasshopper
(d) ZW-ZZ method of Sex Determination	(iv) Female homogametic

Select the correct option from the following :

- (1) (a)-(i), (b)-(iv), (c)-(ii), (d)-(iii)
- (2) (a)-(iii), (b)-(iv), (c)-(i), (d)-(ii)
- (3) (a)-(iv), (b)-(ii), (c)-(i), d-(iii)
- (4) (a)-(ii), (b)-(iv), (c)-(i), (d)-(iii)

**Answer (2)**

**Sol.** XX-XO type sex determination- Grasshopper

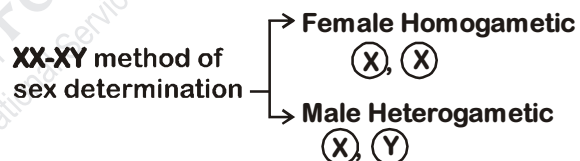

Karyotype-45 — Turner's syndrome

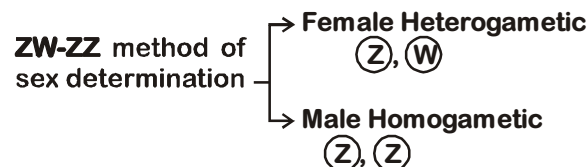

51. What will be the sequence of mRNA produced by the following stretch of DNA?

3' ATGCATGCATGCATG 5' TEMPLATE STRAND

5' TACGTACGTACGTAC 3' CODING STRAND

- (1) 5' UACGUACGUACGUAC 3'
- (2) 3' UACGUACGUACGUAC 5'
- (3) 3' AUGCAUGCAUGCAUG 3'
- (4) 3' AUGCAUGCAUGCAUG 5'

**Answer (1)**

**Sol.** 5' TACGTACGTACGTAC 3' (Coding strand)

5' UACGUACGUACGUAC 3' (m-RNA)

In m-RNA at the place of thymine in coding strand uracil remain present.

52. Select the incorrect statement regarding inbreeding.
- (1) Inbreeding is necessary to evolve a pure line in any animal
  - (2) Continued inbreeding reduces fertility and leads to inbreeding depression
  - (3) Inbreeding depression cannot be overcome by out-crossing
  - (4) Inbreeding helps in elimination of deleterious alleles from the population

Answer (3)

Sol. A single outcross often helps to overcome inbreeding depression. Inbreeding increases homozygosity and close inbreeding usually reduces fertility and even productivity causing inbreeding depression.

53. A biocontrol agent to be a part of an integrated pest management should be
- (1) Free living and broad spectrum
  - (2) Narrow spectrum and symbiotic
  - (3) Species-specific and inactive on non-target organisms
  - (4) Species-specific and symbiotic

Answer (3)

Sol. A good biocontrol agent should be species-specific and inactive on non-target organisms.

54. Match the following enzymes with their functions:
- |                             |       |  |
|-----------------------------|-------|--|
| a. Restriction endonuclease | (i)   | Joins the DNA fragments                  |
| b. Restriction exonuclease  | (ii)  | Extends primers on genomic DNA template  |
| c. DNA ligase               | (iii) | Cuts DNA at specific position            |
| d. Tag polymerase           | (iv)  | Removes nucleotides from the ends of DNA |

Select the correct option from the following:

- (1) a(iii), b(iv), c(i), d(ii)
- (2) a(iv), b(iii), c(i), d(ii)
- (3) a(ii), b(iv), c(i), d(iii)
- (4) a(iii), b(i), c(iv), d(ii)

Answer (1)

- Sol. a. Restriction endonuclease : Cuts DNA at specific position
- b. Restriction Exonuclease : Removes nucleotides from the ends of DNA
- c. DNA ligase : Joins the DNA fragments
- d. Taq polymerase : Extends primers on genomic DNA template

55. The two antibiotic resistance genes on vector pBR 322 are for
- (1) Ampicillin and Chloramphenicol
  - (2) Chloramphenicol and Tetracycline
  - (3) Tetracycline and Kanamycin
  - (4) Ampicillin and Tetracycline

Answer (4)

Sol. *E. Coli* cloning vector pBR322 contains antibiotic resistance genes for Ampicillin and Tetracycline.

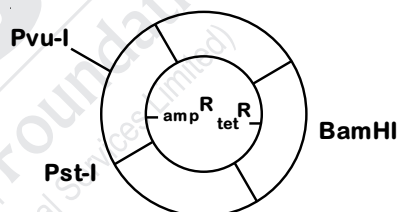

56. Exploitation of bioresources of a nation by multinational companies without authorization from the concerned country is referred to as
- |               |               |
|---------------|---------------|
| (1) Biopiracy | (2) Bioethics |
| (3) Biowar    | (4) Bioweapon |

Answer (1)

Sol. Biopiracy is the term used to refer to the use of bio-resources by multinational companies and other organisations without proper authorisation from the countries and people concerned without compensatory payment.

Biowar/warfare in which disease-producing microorganism, toxins, or organic biocides *e.g.* *Bacillus anthracis* or *Yersinia pestis* used to destroy, injure or immobilize livestock, vegetation, or human life.

Biological warfare/Germ warfare/Bioweapon → use of biological toxins or infectious agents such as bacteria, viruses and fungi with the intent to kill human, animal or plant.

Bioethics is the study of the ethical issues emerging from advances in biology and medicine.

57. Carnivorous animals - lions and leopards, occupy the same niche but lions predate mostly larger animals and leopards take smaller ones. This mechanism of competition is referred to as-

- (1) Altruism
- (2) Resource partitioning
- (3) Competitive exclusion
- (4) Character displacement

**Answer (2)**

**Sol.** If two species compete for the same resource, they could avoid competition by choosing, for instance different times for feeding or different foraging patterns. Such mechanism is called resource partitioning.

58. Decline in the population of Indian native fishes due to introduction of *Clarias gariepinus* in river Yamuna can be categorised as

- (1) Habitat fragmentation
- (2) Over exploitation
- (3) Alien species invasion
- (4) Co-extinction

**Answer (3)**

**Sol.** Introduction of the African catfish *Clarias gariepinus* for aquaculture purposes has become a threat to indigenous catfishes in our rivers.

*Clarias gariepinus* is an alien species for the communities in Yamuna.

59. Match the following genera with their respective phylum :

- |                     |                      |
|---------------------|----------------------|
| (a) <i>Ophiura</i>  | (i) Mollusca         |
| (b) <i>Physalia</i> | (ii) Platyhelminthes |
| (c) <i>Pinctada</i> | (iii) Echinodermata  |
| (d) <i>Planaria</i> | (iv) Coelenterata    |

Select the correct option :

- (1) (a)-(iii), (b)-(iv), (c)-(i), (d)-(ii)
- (2) (a)-(i), (b)-(iii), (c)-(iv), (d)-(ii)
- (3) (a)-(iii), (b)-(iv), (c)-(ii), (d)-(i)
- (4) (a)-(iv), (b)-(i), (c)-(iii), (d)-(ii)

**Answer (1)**

**Sol.** (a) *Ophiura* is an Echinoderm commonly known as brittle star.

(b) *Physalia* is coelenterate (Cnidarian) commonly known as portuguese man of war.

(c) *Pinctada* is pearl oyster belonging to taxon bivalve molluscs.

(d) *Planaria* belongs to platyhelminthes (flatworms).

60. Which of the following animals are true coelomates with bilateral symmetry ?

- |                   |                       |
|-------------------|-----------------------|
| (1) Aschelminthes | (2) Platyhelminthes   |
| (3) Annelids      | (4) Adult Echinoderms |

**Answer (3)**

**Sol.** • Annelids exhibit bilateral symmetry with metameric segmentation where external segments correspond to internal segments.

• Aschelminthes are pseudocoelomates and platyhelminthes are acoelomates.

• Adult echinoderms are bilaterally symmetrical.

61. The contrasting characteristics generally in a pair used for identification of animals in Taxonomic Key are referred to as :

- |               |             |
|---------------|-------------|
| (1) Couplet   | (2) Doublet |
| (3) Alternate | (4) Lead    |

**Answer (1)**

**Sol.** The keys are based on the set of contrasting characters in pair known as couplet.

62. Match the following cell structure with its characteristic feature :

- |                        |   |
|------------------------|---|
| (a) Tight junctions    | (i) Cement neighbouring cells together to form sheet                          |
| (b) Adhering junctions | (ii) Transmit information through chemical to another cells                   |
| (c) Gap junctions      | (iii) Establish a barrier to prevent leakage of fluid across epithelial cells |
| (d) Synaptic junctions | (iv) Cytoplasmic channels to facilitate communication between adjacent cells  |

Select correct option from the following :

- (1) (a)-(iv), (b)-(ii), (c)-(i), (d)-(iii)
- (2) (a)-(iii), (b)-(i), (c)-(iv), (d)-(ii)
- (3) (a)-(iv), (b)-(iii), (c)-(i), (d)-(ii)
- (4) (a)-(ii), (b)-(iv), (c)-(i), (d)-(iii)

**Answer (2)**

**Sol.** • Tight junctions provide a barrier which prevents leakage of fluid across epithelial cells.

- Adherens junctions aid to cement adjacent cells to form a sheet.
- Gap junctions provide cytoplasmic channels to facilitate communication between adjacent cells.
- Synaptic junctions help in transmission of information through chemicals.

63. Which of the following statements is INCORRECT ?

- (1) A mushroom-shaped gland is present in the 6<sup>th</sup>-7<sup>th</sup> abdominal segments of male cockroach.
- (2) A pair of spermatheca is present in the 6<sup>th</sup> segment of female cockroach
- (3) Female cockroach possesses sixteen ovarioles in the ovaries.
- (4) Cockroaches exhibit mosaic vision with less sensitivity and more resolution.

**Answer (4)**

**Sol.** Cockroaches receive several images of an object with the help of ommatidia. This kind of vision possessed by cockroaches is known as mosaic vision which has more sensitivity but less resolution.

64. Match the following RNA polymerases with their transcribed products :

- |                        |             |
|------------------------|-------------|
| (a) RNA polymerase I   | (i) tRNA    |
| (b) RNA polymerase II  | (ii) rRNA   |
| (c) RNA polymerase III | (iii) hnRNA |

Select the correct option from the following :

- (1) (a)-(i), (b)-(ii), (c)-(iii)
- (2) (a)-(ii), (b)-(iii), (c)-(i)
- (3) (a)-(iii), (b)-(ii), (c)-(i)
- (4) (a)-(i), (b)-(iii), (c)-(ii)

**Answer (2)**

**Sol.** In eukaryotes, there are three types of RNA polymerases.

RNA polymerase I transcribes rRNAs,

RNA polymerase II transcribes hnRNAs,

and RNA polymerase III transcribes tRNAs.

65. In a marriage between male with blood group A and female with blood group B, the progeny had either blood group AB or B. What could be the possible genotype of parents?

- (1)  $I^A I^A$  (Male) ;  $I^B I^B$  (Female)
- (2)  $I^A I^A$  (Male) ;  $I^B i$  (Female)
- (3)  $I^A i$  (Male) ;  $I^B i$  (Female)
- (4)  $I^A i$  (Male) ;  $I^B I^B$  (Female)

**Answer (4)**

**Sol.** Male with blood group A can have genotype  $I^A i$  or  $I^A I^A$ .

Female with blood group B can have genotype  $I^B I^B$ , or  $I^B i$

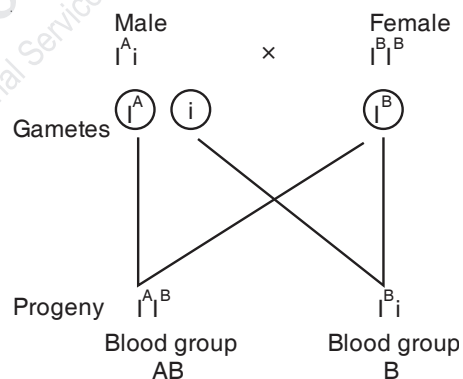

66. A population of a species invades a new area. Which of the following condition will lead to Adaptive Radiation?

- (1) Area with a single type of vacant habitat
- (2) Area with many types of vacant habitats.
- (3) Area with many habitats occupied by a large number of species.
- (4) Area with large number of habitats having very low food supply.

**Answer (2)**

**Sol.** When a population of a species invades a new area with many type of vacant habitats, they face different environmental pressures and eventually adapt exhibiting adaptive radiation.

67. Identify A, B and C in the diagrammatic representation of the mechanism of hormone action.

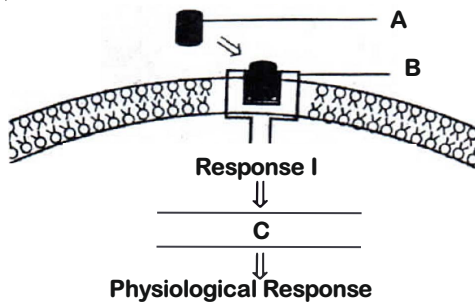

Select the correct option from the following :

- (1) A = Protein Hormone; B = Receptor  
C = Cyclic AMP
- (2) A = Steroid Hormone; B = Receptor;  
C = Second Messenger
- (3) A = Protein Hormone; B = Cyclic AMP;  
C = Hormone-receptor Complex
- (4) A = Steroid Hormone; B = Hormone-receptor Complex; C = Protein

**Answer (1)**

**Sol.** 'A' is a hormone such as FSH that cannot cross lipid bilayer therefore it interacts with the membrane-bound receptors and does not enter the target cell, but generates second messengers. Peptide, polypeptide, protein hormones and catecholamines act through this mechanism.

'B' represents the extracellular receptors present on cell surface that forms a hormone-receptor complex which brings about conformational changes in the cytoplasmic part of the receptor. This cytoplasmic part can produce second messengers such as  $Ca^{+2}$ , cAMP,  $IP_3$  etc. which activates the existing enzyme system of the cell and accelerates the biochemical reactions in the cell.

'C' represents the second messenger.

68. Humans have acquired immune system that produces antibodies to neutralize pathogens. Still innate immune system is present at the time of birth because it
- (1) produces memory cells for mounting fast secondary response.
  - (2) has natural killer cells which can phagocytose and destroy microbes
  - (3) provides passive immunity
  - (4) is very specific and uses different macrophages.

**Answer (2)**

**Sol.** Innate immunity is non-specific and is accomplished by providing different types of barriers to the entry of foreign agent or any pathogen into our body.

- Passive immunity is specific and is a branch of humoral immunity.
- Natural killer cells are a type of lymphocytes which will produce proteins called perforins that create pores on plasma membrane of tumor cells and virally infected cells through which ECF enters and kill the cells.
- Innate immunity does not produce memory cells hence, no secondary immune response is seen.

69. Which of the following statements is not correct ?

- (1) Depolarisation of hair cells of cochlea results in the opening of the mechanically gated potassium-ion channels
- (2) Rods are very sensitive and contribute to daylight vision
- (3) In the knee-jerk reflex, stimulus is the stretching of muscle and response is its contraction
- (4) An action potential in an axon does not move backward because the segment behind is in a refractory phase

**Answer (2)**

**Sol.** Cones are very sensitive to operate in day light. Rods are very sensitive in dim light. In cochlea, endolymph contains large amount of  $K^+$  ions.

Depolarisation of sensory hair cells present in cochlea takes place by opening of mechanical gated  $K^+$  channels.

70. Match the following joints with the bones involved:
- |                   |  |
|-------------------|--|
| (a) Gliding joint | (i) Between carpal and metacarpal of thumb |
| (b) Hinge joint   | (ii) Between Atlas and Axis                |
| (c) Pivot joint   | (iii) Between the Carpals                  |
| (d) Saddle joint  | (iv) Between Humerus and Ulna              |

Select the correct option from the following :

- (1) (a)-(iv), (b)-(i), c-(ii), (d)-(iii)
- (2) (a)-(iv), (b)-(ii), c-(iii), (d)-(i)
- (3) (a)-(i), (b)-(iii), c-(ii), (d)-(iv)
- (4) (a)-(iii), (b)-(iv), c-(ii), (d)-(i)

**Answer (4)**

- Sol.**
- Gliding joint is present between the carpals.
  - Hinge joint is present between humerus and ulna.
  - Pivot joint is present between atlas and axis.
  - Saddle joint is present between carpal and metacarpal of thumb.

71. Which of the following diseases is an autoimmune disorder ?

- (1) Arthritis                      (2) Osteoporosis  
(3) Gout                              (4) Myasthenia gravis

**Answer (4)**

**Sol.** Myasthenia gravis is autoimmune disorder that affects neuromuscular junction leading to fatigue, weakening and paralysis of skeletal muscles.

- Arthritis is inflammation of joints.
- Gout is inflammation of joints due to accumulation of uric acid crystals.
- Osteoporosis is age related disorder characterised by decreased bone mass and increased chances of fractures.

72. Artificial light, extended work-time and reduced sleep-time disrupt the activity of –

- (1) Pineal gland  
(2) Adrenal gland  
(3) Posterior pituitary gland  
(4) Thymus gland

**Answer (1)**

**Sol.** Artificial light, extended work time and reduced sleep-time disrupt the activity of pineal gland.

Melatonin hormone of pineal gland plays a very important role in the regulation of a 24-hours (diurnal) rhythm of our body. Melatonin helps in maintaining the normal rhythms of sleep-wake cycle and body temperature.

73. Which of the following conditions will stimulate parathyroid gland to release parathyroid hormone ?

- (1) Fall in blood  $Ca^{+2}$  levels  
(2) Fall in bone  $Ca^{+2}$  levels  
(3) Rise in blood  $Ca^{+2}$  levels  
(4) Fall in active Vitamin D levels

**Answer (1)**

**Sol.** Parathyroid hormone (PTH) is a hypercalcemic hormone. *i.e.* it increases the blood  $Ca^{2+}$  level. PTH acts on bones and stimulates the process of bone resorption (dissolution/demineralisation). PTH also stimulates reabsorption of  $Ca^{2+}$  by the renal tubules and increases  $Ca^{2+}$  absorption from the digested food.

74. Which of the following is a correct statement ?

- (1) IUDs are generally inserted by the user herself  
(2) IUDs increase phagocytosis of sperms in the uterus  
(3) IUDs suppress gametogenesis  
(4) IUDs once inserted need not be replaced

**Answer (2)**

**Sol.** IUDs of all types are in general treated as a foreign body thus inviting phagocytic cells to the uterus.

- IUDs increase phagocytosis of sperms within the uterus and Cu ions released suppress sperm motility and the fertilising capacity of sperms.
- IUDs need to be inserted by an experienced nurse and have to be replaced after few years depending on copper or hormonal level.

75. Which of the following sexually transmitted diseases do not specifically affect reproductive organs ?

- (1) Syphilis and Genital herpes  
(2) AIDS and Hepatitis B  
(3) Chlamydiasis and AIDS  
(4) Genital warts and Hepatitis-B

**Answer (2)**

**Sol.** AIDS and Hepatitis B are sexually transmitted infections. However, they do not specifically affect the reproductive organs only.

- AIDS is HIV infection affecting the immune system and opportunistic pathogens can infect various body organs.
- Hepatitis B affects liver.
- Agents causing genital herpes, genital warts and chlamydiasis produce lesions on genital organs and also directly affect the reproductive system.

76. Which of the following cell organelles is present in the highest number in secretory cells?

- (1) Golgi complex
- (2) Endoplasmic reticulum
- (3) Lysosome
- (4) Mitochondria

**Answer (1)**

**Sol.** The important function of Golgi apparatus is to process, package and transport the materials for secretion. Therefore secretory cells have Golgi apparatus in highest number.

77. Non-membranous nucleoplasmic structures in nucleus are the site for active synthesis of

- (1) mRNA
- (2) rRNA
- (3) tRNA
- (4) protein synthesis

**Answer (2)**

**Sol.** Nucleolus is non-membranous nucleoplasmic structure in nucleus.

Nucleolus is the site of ribosomal RNA (rRNA) synthesis.

78. Which of the following nucleic acids is present in an organism having 70 S ribosomes only?

- (1) Double stranded circular naked DNA
- (2) Double stranded DNA enclosed in nuclear membrane
- (3) Double stranded circular DNA with histone proteins
- (4) Single stranded DNA with protein coat

**Answer (1)**

**Sol.** The organisms which have ribosomes of 70 S type are prokaryotes. Prokaryotes have double stranded DNA which is not enclosed in membrane.

79. After meiosis I, the resultant daughter cells have

- (1) twice the amount of DNA in comparison to haploid gamete.
- (2) same amount of DNA in comparison to haploid gamete.
- (3) four times the amount of DNA in comparison to haploid gamete.
- (4) same amount of DNA as in the parent cell in S phase.

**Answer (1)**

**Sol.** Meiosis I is reductional division thus the resultant cell just after meiosis I will have half the number of chromosomes as compared to diploid parent cells. Therefore if the parent cell has 4C amount of DNA the daughter cell will have 2C amount of DNA and each gamete will have 1C amount of DNA.

80. Which of the following organic compounds is the main constituent of Lecithin?

- (1) Phospholipid
- (2) Cholesterol
- (3) Phosphoprotein
- (4) Arachidonic acid

**Answer (1)**

**Sol.** Lecithin is an example of phospholipids found in cell membrane.

Casein is a phosphoprotein found in milk

81. The main difference between active and passive transport across cell membrane is :

- (1) passive transport requires a concentration gradient across a biological membrane whereas active transport requires energy to move solutes.
- (2) passive transport is confined to anionic carrier proteins whereas active transport is confined to cationic channel proteins.
- (3) active transport occurs more rapidly than passive transport.
- (4) passive transport is non-selective whereas active transport is selective.

**Answer (1)**

**Sol.** In active transport, materials are transported across a membrane with the help of mobile carrier protein and ATP.

In passive transport, substances move along the concentration gradient, i.e., from its higher concentration to its lower concentration.

82. Match the items given in Column-I with those in Column-II and choose the correct option.

Column-I	Column-II
(a) Rennin	(i) Vitamin B <sub>12</sub>
(b) Enterokinase	(ii) Facilitated transport
(c) Oxyntic cells	(iii) Milk proteins
(d) Fructose	(iv) Trypsinogen

- (1) (a)-(iv), (b)-(iii), (c)-(i), (d)-(ii)
- (2) (a)-(iv), (b)-(iii), (c)-(ii), (d)-(i)
- (3) (a)-(iii), (b)-(iv), (c)-(i), (d)-(ii)
- (4) (a)-(iii), (b)-(iv), (c)-(ii), (d)-(i)

**Answer (3)**

**Sol.** Rennin is a milk digesting protein enzyme.

Enterokinase converts trypsinogen into trypsin.

Fructose shows facilitated transport oxyntic cells secrete HCl and intrinsic factors that are essential for absorption of vitamin B<sub>12</sub>.

83. Kwashiorkor disease is due to -

- (1) simultaneous deficiency of proteins and calories
- (2) deficiency of carbohydrates
- (3) protein deficiency not accompanied by calorie deficiency
- (4) simultaneous deficiency of proteins and fats

**Answer (3)**

**Sol.** Kwashiorkor is produced by protein deficiency but unaccompanied by calorie deficiency. It results from the replacement of mother's milk by a high calorie-low protein diet in a child more than one year in age.

84. Select the correct statement.

- (1) Intrapulmonary pressure is lower than the atmospheric pressure during inspiration.
- (2) Inspiration occurs when atmospheric pressure is less than intrapulmonary pressure.
- (3) Expiration is initiated due to contraction of diaphragm.
- (4) Expiration occurs due to external intercostal muscles.

**Answer (1)**

**Sol.** During inspiration, diaphragm and external intercostal muscles contract causing increase in volume of thoracic cage. As a result intrapulmonary pressure decreases to a level less than atmospheric pressure, thus causing inspiration.

Expiration is initiated due to relaxation of diaphragm.

85. The maximum volume of air a person can breathe in after a forced expiration is known as :

- (1) Vital Capacity
- (2) Inspiratory Capacity
- (3) Total Lung Capacity
- (4) Expiratory Capacity

**Answer (1)**

**Sol.** Maximum amount of air expired by a person after forceful inspiration or inspired after forceful expiration is known as vital capacity 4600 ml

Total amount of air in lungs at end of forceful inspiration is total lung capacity 5800 ml

86. All the components of the nodal tissue are autoexcitable. Why does the SA node act as the normal pacemaker?

- (1) SA node is the only component to generate the threshold potential.
- (2) Only SA node can convey the action potential to the other components.
- (3) SA node has the highest rate of depolarisation.
- (4) SA node has the lowest rate of depolarisation.

**Answer (3)**

**Sol.** SA node acts as pace-maker of heart because its autoexcitable tissue generates heart impulses at highest rate (frequency).

87. A specialised nodal tissue embedded in the lower corner of the right atrium, close to Atrio-ventricular septum, delays the spreading of impulses to heart apex for about 0.1 sec. This delay allows

- (1) the ventricles to empty completely.
- (2) blood to enter pulmonary arteries.
- (3) the atria to empty completely.
- (4) blood to enter aorta.

**Answer (3)**

**Sol.** The delay in transmission of impulse from SAN to the ventricles provided by AVN prevents simultaneous contraction of ventricles and auricles. This allows atria to empty completely before ventricles start contraction.

88. Match the following parts of a nephron with their function :

- |                                     |   |
|-------------------------------------|---|
| (a) Descending limb of Henle's loop | (i) Reabsorption of salts only                          |
| (b) Proximal convoluted tubule      | (ii) Reabsorption of water only                         |
| (c) Ascending limb of Henle's loop  | (iii) Conditional reabsorption of sodium ions and water |
| (d) Distal convoluted tubule        | (iv) Reabsorption of ions, water and organic nutrients  |

Select the correct option from the following :

- (1) (a)-(ii), (b)-(iv), (c)-(i), (d)-(iii)
- (2) (a)-(i), (b)-(iv), (c)-(ii), (d)-(iii)
- (3) (a)-(iv), (b)-(i), (c)-(iii), (d)-(ii)
- (4) (a)-(i), (b)-(iii), (c)-(ii), (d)-(iv)

**Answer (1)**

**Sol.** ⇒ Descending limb of Henle's loop → Reabsorption of water only  
 ⇒ PCT → Reabsorption of ions, water organic nutrients  
 ⇒ Ascending limb of Henle's loop → Reabsorption of salts only.  
 ⇒ DCT → Conditional reabsorption of sodium ions and water

89. Match the items in Column-I with those in Column-II

- | Column-I           | Column-II                 |
|--------------------|---------------------------|
| (a) Podocytes      | (i) Crystallised oxalates |
| (b) Protonephridia | (ii) Annelids             |
| (c) Nephridia      | (iii) Amphioxus           |
| (d) Renal calculi  | (iv) Filtration slits     |

Select the correct option from the following :

- (1) (a)-(iii), (b)-(ii), (c)-(iv), (d)-(i)
- (2) (a)-(iv), (b)-(iii), (c)-(ii), (d)-(i)
- (3) (a)-(iv), (b)-(ii), (c)-(iii), (d)-(i)
- (4) (a)-(iii), (b)-(iv), (c)-(ii), (d)-(i)

**Answer (2)**

**Sol.** Podocytes → Filtration slits  
 Protonephridia → *Amphioxus*  
 Nephridia → Annelids  
 Renal calculi → Crystallised oxalates

90. Which of the following receptors are specifically responsible for maintenance of balance of body and posture?

- (1) Hair cells and organ of corti
- (2) Tectorial membrane and macula
- (3) Crista ampullaris and macula
- (4) Basilar membrane and otoliths

**Answer (3)**

**Sol.** Crista ampullaris → Maintains the dynamic balance of the body  
 Otolith organ → Consists of two structures *i.e.* saccule and utricle  
 → The projecting ridge of the saccule and utricle is called macula.  
 → The otolith organ maintains the static balance of the body

91. In a u-tube as shown in the fig. water and oil are in the left side and right side of the tube respectively. The heights from the bottom for water and oil columns are 15 cm and 20 cm respectively. The density of the oil is

[take  $\rho_{\text{water}} = 1000 \text{ kg/m}^3$ ]

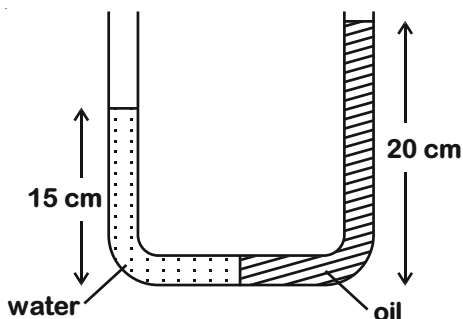

- (1)  $750 \text{ kg/m}^3$                       (2)  $1000 \text{ kg/m}^3$   
(3)  $1333 \text{ kg/m}^3$                     (4)  $1200 \text{ kg/m}^3$

**Answer (1)**

**Sol.** In equilibrium

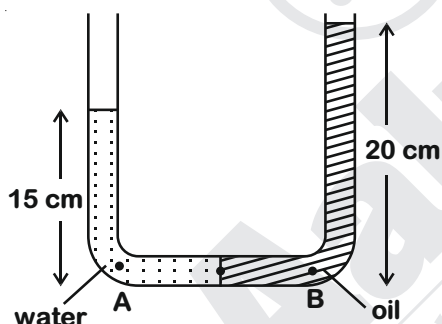

Pressure at A = Pressure at B.

$$P_a + 0.15 \times 10^3 \times g = P_a + 0.20 \times d_0 \times g$$

$$d_0 = \frac{0.15 \times 10^3}{0.20}$$

$$= 0.75 \times 10^3$$

$$= 750 \text{ kg/m}^3$$

92. A deep rectangular pond of surface area  $A$ , containing water (density =  $\rho$ ), specific heat capacity =  $s$ ), is located in a region where the outside air temperature is at a steady value of  $-26^\circ\text{C}$ . The thickness of the frozen ice layer in this pond, at a certain instant is  $x$ .

Taking the thermal conductivity of ice as  $K$ , and its specific latent heat of fusion as  $L$ , the rate of increase of the thickness of ice layer, at this instant, would be given by

- (1)  $26K/(\rho x^2 L)$                       (2)  $26K/(\rho x L)$   
(3)  $26K/\rho x(L + 4s)$                 (4)  $26K/\rho x(L - 4s)$

**Answer (2)**

**Sol.** Assume at any instant thickness of ice is  $x$ . And time taken to form additional thickness ( $dx$ ) is  $dt$ .

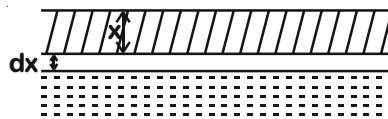

$$mL = \frac{KA[26 - 0]dt}{x}$$

$$(A dx)\rho L = \frac{KA(26)dt}{x}$$

$$\frac{dx}{dt} = \frac{26 K}{x \rho L}$$

93. An LED is constructed from a p-n junction diode using GaAsP. The energy gap is 1.9 eV. The wavelength of the light emitted will be equal to

- (1) 654 nm                                      (2) 654 Å  
(3)  $654 \times 10^{-11} \text{ m}$                       (4)  $10.4 \times 10^{-26} \text{ m}$

**Answer (1)**

**Sol.** Wavelength of light emitted.

$$\lambda = \frac{12400}{E_g \text{ (in eV)}} \text{ Å}$$

$$= \frac{12400}{1.9} = 6526 \text{ Å}$$

$$= 653 \text{ nm}$$

$$\approx 654 \text{ nm}$$

94. The circuit diagram shown here corresponds to the logic gate,

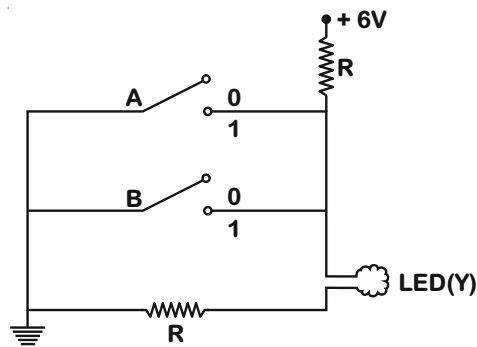

- (1) AND    (2) OR  
(3) NAND    (4) NOR

**Answer (4)**

**Sol. Case-1 : A = 0, B = 0**

LED will glow

∴ Y = 1

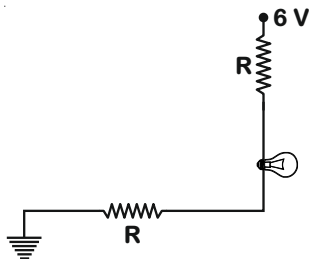

**Case-2 : A = 0, B = 1**

No current will through LED

∴ Y = 0

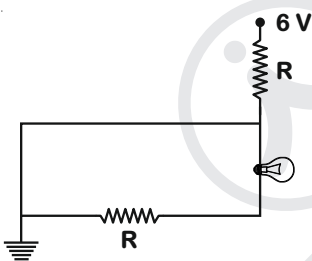

**Case-3 : A = 1, B = 0**

Again no current will through LED

∴ Y = 0

**Case-4 : A = 1, B = 1**

Again Y = 0

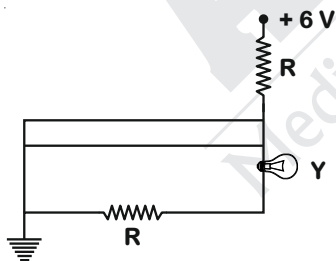

∴

A	B	Y
0	0	1
0	1	0
1	0	0
1	1	0

NOR gate.

95. The value of  $\gamma \left( = \frac{C_p}{C_v} \right)$ , for hydrogen, helium

and another ideal diatomic gas X (whose molecules are not rigid but have an additional vibrational mode), are respectively equal to,

(1)  $\frac{5}{3}, \frac{7}{5}, \frac{9}{7}$

(2)  $\frac{5}{3}, \frac{7}{5}, \frac{7}{5}$

(3)  $\frac{7}{5}, \frac{5}{3}, \frac{7}{5}$

(4)  $\frac{7}{5}, \frac{5}{3}, \frac{9}{7}$

**Answer (4)**

**Sol.** Diatomic gases have 5 degrees of freedom, if vibrational mode is neglected. And if vibrational mode is also considered then degrees of freedom of diatomic gas molecules are 7.

For Hydrogen  $\gamma = 1 + \frac{2}{f} = 1 + \frac{2}{5} = \frac{7}{5}$

For Helium  $\gamma = 1 + \frac{2}{f} = 1 + \frac{2}{3} = \frac{5}{3}$

For gas X (vibrational mode also considered)  $f = 7$ .

$\gamma = 1 + \frac{2}{f} = 1 + \frac{2}{7} = \frac{9}{7}$

So,  $\left( \frac{7}{5}, \frac{5}{3}, \frac{9}{7} \right)$

96. Two metal spheres, one of radius R and the other of radius 2R respectively have the same surface charge density  $\sigma$ . They are brought in contact and separated. What will be the new surface charge densities on them?

(1)  $\sigma_1 = \frac{5}{2}\sigma, \sigma_2 = \frac{5}{6}\sigma$       (2)  $\sigma_1 = \frac{5}{2}\sigma, \sigma_2 = \frac{5}{3}\sigma$

(3)  $\sigma_1 = \frac{5}{3}\sigma, \sigma_2 = \frac{5}{6}\sigma$       (4)  $\sigma_1 = \frac{5}{6}\sigma, \sigma_2 = \frac{5}{2}\sigma$

**Answer (3)**

**Sol.**  $Q_1 = \sigma 4\pi R_1^2 = \sigma 4\pi R^2$

$Q_2 = \sigma 4\pi (2R)^2 = \sigma 16\pi R^2$

After Redistribution of charges

$\frac{Q'_1}{Q'_2} = \frac{R}{2R} \Rightarrow Q'_2 = 2Q'_1 \dots(i)$

$Q'_1 + Q'_2 = 20\sigma\pi R^2 \dots(ii)$

From eq. (i) and (ii)

$Q'_1 = \frac{20}{3}\sigma\pi R^2 \Rightarrow \sigma'_1 = \frac{5}{3}\sigma$

$Q'_2 = \frac{40}{3}\sigma\pi R^2 \Rightarrow \sigma'_2 = \frac{5}{6}\sigma$

97. The distance covered by a particle undergoing SHM in one time period is (amplitude = A),

- (1) A (2) 2A  
(3) 4A (4) Zero

Answer (3)

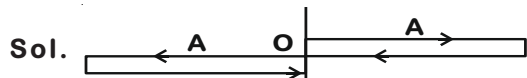

In one time period total distance travelled by the particle is 4A.

98. A mass falls from a height 'h' and its time of fall 't' is recorded in terms of time period T of a simple pendulum. On the surface of earth it is found that  $t = 2T$ . The entire set up is taken on the surface of another planet whose mass is half of that of earth and radius the same. Same experiment is repeated and corresponding times noted as  $t'$  and  $T'$ .

Then we can say

- (1)  $t' > 2T'$  (2)  $t' < 2T'$   
(3)  $t' = 2T'$  (4)  $t' = \sqrt{2}T'$

Answer (3)

Sol. For surface of earth time taken in falling h distance.

$$t = \sqrt{\frac{2h}{g}}$$

and  $T = 2\pi\sqrt{\frac{l}{g}}$

Given  $t = 2T$

$$\frac{t}{T} = 2$$

For surface of other planet

$$g' = \frac{g}{2}$$

Time taken in falling h distance

$$t' = \sqrt{\frac{2h}{g'}} = \sqrt{2}t$$

and  $T' = 2\pi\sqrt{\frac{l}{g'}} = \sqrt{2}T$

Here  $\frac{t'}{T'} = \frac{\sqrt{2}t}{\sqrt{2}T} = 2$

$$\boxed{t' = 2T'}$$

99. A tuning fork with frequency 800 Hz produces resonance in a resonance column tube with upper end open and lower end closed by water surface. Successive resonance are observed at lengths 9.75 cm, 31.25 cm and 52.75 cm. The speed of sound in air is,

- (1) 156 m/s (2) 344 m/s  
(3) 172 m/s (4) 500 m/s

Answer (2)

Sol.  $l_1 = 9.75$  cm

$$l_2 = 31.25$$
 cm

$$l_3 = 52.75$$
 cm

e = end correction

$$\frac{\lambda}{4} + e = 9.75 \text{ cm} \quad \dots (1)$$

$$\frac{3\lambda}{4} + e = 31.25 \text{ cm} \quad \dots (2)$$

$$\frac{3\lambda}{4} - \frac{\lambda}{4} = 31.25 - 9.75$$

$$\frac{\lambda}{2} = 21.5$$

$$\lambda = 43 \text{ cm}$$

$$v = \lambda \times f$$

$$v = 43 \times 800$$

$$v = 34400 \times 10^{-2}$$

$$\boxed{v = 344 \text{ m/s}}$$

100. An object flying in air with velocity  $(20\hat{i} + 25\hat{j} - 12\hat{k})$  suddenly breaks into two pieces whose masses are in the ratio 1 : 5. The smaller mass flies off with a velocity  $(100\hat{i} + 35\hat{j} + 8\hat{k})$ . The velocity of the larger piece will be,

- (1)  $-100\hat{i} - 35\hat{j} - 8\hat{k}$   
(2)  $20\hat{i} + 15\hat{j} - 80\hat{k}$   
(3)  $-20\hat{i} - 15\hat{j} - 80\hat{k}$   
(4)  $4\hat{i} + 23\hat{j} - 16\hat{k}$

**Answer (4)****Sol.** By conservation of linear momentum

$$\vec{P}_i = \vec{P}_f$$

$$m\vec{v}_i = \left( \frac{m}{6}\vec{v}_1 + \frac{5m}{6}\vec{v}_2 \right)$$

$$\vec{v}_i = \left( \frac{\vec{v}_1}{6} + \frac{5}{6}\vec{v}_2 \right)$$

$$20\hat{i} + 25\hat{j} - 12\hat{k} = \frac{(100\hat{i} + 35\hat{j} + 8\hat{k})}{6} + \frac{5\vec{v}_2}{6}$$

$$120\hat{i} + 150\hat{j} - 72\hat{k} = 100\hat{i} + 35\hat{j} + 8\hat{k} + 5\vec{v}_2$$

$$20\hat{i} + 115\hat{j} - 60\hat{k} = 5\vec{v}_2$$

$$\vec{v}_2 = \frac{20\hat{i} + 115\hat{j} - 60\hat{k}}{5}$$

$$\boxed{\vec{v}_2 = 4\hat{i} + 23\hat{j} - 12\hat{k}}$$

101. The main scale of a vernier callipers has  $n$  divisions/cm.  $n$  divisions of the vernier scale coincide with  $(n - 1)$  divisions of main scale. The least count of the vernier callipers is,

(1)  $\frac{1}{n}$  cm

(2)  $\frac{1}{n^2}$  cm

(3)  $\frac{1}{n(n+1)}$  cm

(4)  $\frac{1}{(n+1)(n-1)}$  cm

**Answer (2)****Sol.**  $n$  VSD =  $(n - 1)$  MSD

$$1\text{VSD} = \frac{(n-1)}{n} \text{MSD}$$

$$\text{L.C.} = 1\text{MSD} - 1\text{VSD}$$

$$= 1\text{MSD} - \frac{(n-1)}{n} \text{MSD}$$

$$= \frac{1}{n} \text{MSD}$$

$$= \frac{1}{n} \times \frac{1}{n} \text{cm}$$

$$= \frac{1}{n^2} \text{cm}$$

102. A person travelling in a straight line moves with a constant velocity  $v_1$  for certain distance 'x' and with a constant velocity  $v_2$  for next equal distance. The average velocity  $v$  is given by the relation

(1)  $\frac{2}{v} = \frac{1}{v_1} + \frac{1}{v_2}$

(2)  $\frac{v}{2} = \frac{v_1 + v_2}{2}$

(3)  $v = \sqrt{v_1 v_2}$

(4)  $\frac{1}{v} = \frac{1}{v_1} + \frac{1}{v_2}$

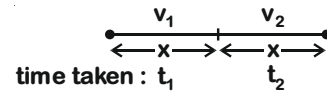
**Answer (1)****Sol.**

$$\text{As } t_1 = \frac{x}{v_1} \text{ and } t_2 = \frac{x}{v_2}$$

$$\begin{aligned} \therefore v &= \frac{x+x}{t_1+t_2} \\ &= \frac{2x}{\frac{x}{v_1} + \frac{x}{v_2}} = \frac{2v_1 v_2}{v_1 + v_2} \end{aligned}$$

$$\therefore \frac{2}{v} = \frac{1}{v_1} + \frac{1}{v_2}$$

103. Assuming that the gravitational potential energy of an object at infinity is zero, the change in potential energy (final - initial) of an object of mass  $m$ , when taken to a height  $h$  from the surface of earth (of radius  $R$ ), is given by,

(1)  $\frac{GMmh}{R(R+h)}$

(2)  $mgh$

(3)  $\frac{GMm}{R+h}$

(4)  $-\frac{GMm}{R+h}$

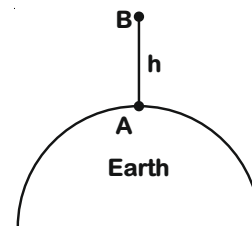
**Answer (1)****Sol.**

$$(P.E)_A = -\frac{GMm}{R}$$

$$(P.E)_B = -\frac{GMm}{R+h}$$

$$\therefore \Delta U = (P.E)_B - (P.E)_A$$

$$= -\frac{GMm}{R+h} + \frac{GMm}{R} = \frac{GMmh}{(R)(R+h)}$$

104. 1 g of water, of volume 1 cm<sup>3</sup> at 100°C, is converted into steam at same temperature under normal atmospheric pressure ( $\approx 1 \times 10^5$  Pa). The volume of steam formed equals 1671 cm<sup>3</sup>. If the specific latent heat of vapourisation of water is 2256 J/g, the change in internal energy is,

- (1) 2089 J                      (2) 167 J  
(3) 2256 J                      (4) 2423 J

**Answer (1)**

**Sol.**  $\Delta Q = 2256 \times 1 = 2256$  J

$$\begin{aligned}\Delta W &= P[V_{\text{steam}} - V_{\text{water}}] \\ &= 1 \times 10^5 [1671 - 1] \times 10^{-6} \\ &= 1670 \times 10^5 \times 10^{-6} \\ &= 167 \text{ J}\end{aligned}$$

By first law of thermodynamics:

$$\text{As } \Delta Q = \Delta U + \Delta W$$

$$2256 = \Delta U + 167$$

$$\Delta U = 2089 \text{ J}$$

105. Angular width of the central maxima in the Fraunhofer diffraction for  $\lambda = 6000 \text{ \AA}$  is  $\theta_0$ . When the same slit is illuminated by another monochromatic light, the angular width decreases by 30%. The wavelength of this light is

- (1) 4200  $\text{\AA}$                       (2) 6000  $\text{\AA}$   
(3) 420  $\text{\AA}$                         (4) 1800  $\text{\AA}$

**Answer (1)**

**Sol.** As  $\theta = \frac{2\lambda}{a}$

$$\theta_0 = \frac{2 \times 6000}{a} \quad \dots \text{(i)}$$

$$\frac{\theta'}{\theta_0} = \frac{\lambda'}{6000} \quad \dots \text{(ii)}$$

$$\Rightarrow \lambda' = 0.7 \times 6000 \quad (\text{as } \theta' = 0.7 \theta_0)$$

$$\Rightarrow 4200 \text{ \AA}$$

106. The work function of a photosensitive material is 4.0 eV. The longest wavelength of light that can cause photon emission from the substance is (approximately)

- (1) 966 nm                      (2) 31 nm  
(3) 310 nm                        (4) 3100 nm

**Answer (3)**

**Sol.** As  $E = \frac{12400}{\lambda}$  (E is in eV and  $\lambda$  is in  $\text{\AA}$ )

$$\lambda = \frac{12400}{4} = 3100 \text{ \AA}$$

$$\therefore \lambda = 310 \text{ nm}$$

107. A proton and an  $\alpha$ -particle are accelerated from rest to the same energy. The de Broglie wavelengths  $\lambda_p$  and  $\lambda_\alpha$  are in the ratio,

- (1) 1 : 1                              (2)  $\sqrt{2} : 1$   
(3) 4 : 1                              (4) 2 : 1

**Answer (4)**

**Sol.** As  $\lambda = \frac{h}{p} = \frac{h}{\sqrt{2mK.E}}$

$$\therefore \lambda \propto \frac{1}{\sqrt{m}} \quad (\text{Kinetic energies are same})$$

$$\frac{\lambda_p}{\lambda_\alpha} = \sqrt{\frac{m_\alpha}{m_p}}$$

$$\frac{\lambda_p}{\lambda_\alpha} = \sqrt{\frac{4m_p}{m_p}}$$

$$\therefore \frac{\lambda_p}{\lambda_\alpha} = \frac{2}{1}$$

108. The radius of the first permitted Bohr orbit, for the electron, in a hydrogen atom equals 0.51  $\text{\AA}$  and its ground state energy equals -13.6 eV. If the electron in the hydrogen atom is replaced by muon ( $\mu^-$ ) [charge same as electron and mass 207  $m_e$ ], the first Bohr radius and ground state energy will be,

- (1) 25.6  $\times 10^{-13}$  m, -2.8 eV  
(2) 2.56  $\times 10^{-13}$  m, -2.8 keV  
(3) 2.56  $\times 10^{-13}$  m, -13.6 eV  
(4) 0.53  $\times 10^{-13}$  m, -3.6 eV

**Answer (2)**

**Sol.**  $r_n \propto \frac{1}{m}$

$$r_\mu = \frac{0.51}{207} = 2.56 \times 10^{-13} \text{ m}$$

$$E \propto m_e$$

$$\begin{aligned}(E)_\mu &= -13.6 \times 207 \\ &= -2.8 \text{ keV}\end{aligned}$$

109. The reading of an ideal voltmeter in the circuit shown is,

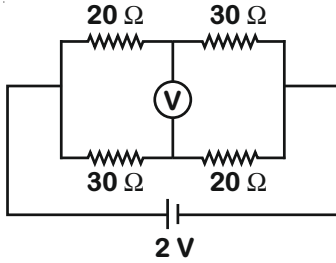

- (1) 0 V                      (2) 0.5 V  
(3) 0.4 V                    (4) 0.6 V

Answer (3)

Sol. Current in APB =  $\frac{2}{50}$  A

Current in AQB =  $\frac{2}{50}$  A

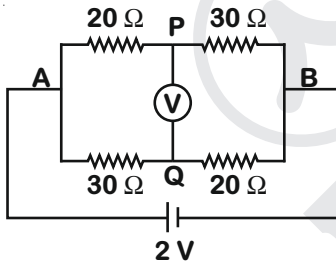

$\Delta V$  from A to P

$$V_A - \frac{2}{50} \times 20 = V_P$$

$\Delta V$  from A to Q

$$V_A - \frac{2}{50} \times 30 = V_Q$$

$$V_P + \frac{2}{50} \times 20 = V_Q + \frac{2}{50} \times 30 \Rightarrow V_P - V_Q = 0.4 \text{ V}$$

110. The metre bridge shown is in balance position with  $\frac{P}{Q} = \frac{l_1}{l_2}$ . If we now interchange the positions of galvanometer and cell, will the bridge work? If yes, what will be balance condition?

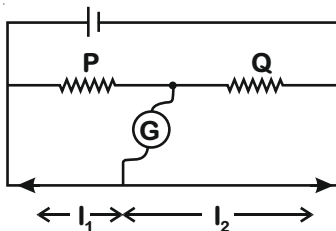

- (1) no, no null point    (2) yes,  $\frac{P}{Q} = \frac{l_2}{l_1}$   
(3) yes,  $\frac{P}{Q} = \frac{l_1}{l_2}$       (4) yes,  $\frac{P}{Q} = \frac{l_2 - l_1}{l_2 + l_1}$

Answer (3)

Sol. In balanced bridge (initially)

$$\frac{P}{Q} = \frac{l_1}{l_2}$$

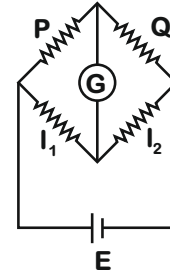

In balanced bridge (finally)

$$\frac{P}{l_1} = \frac{Q}{l_2}$$

$$\frac{P}{Q} = \frac{l_1}{l_2}$$

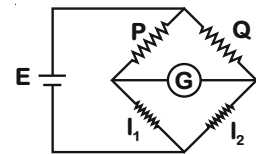

On interchanging galvanometer and battery positions, the balance condition remains unchanged.

111. The relations amongst the three elements of earth's magnetic field, namely horizontal component H, vertical component V and dip  $\delta$  are, ( $B_E$  = total magnetic field)

- (1)  $V = B_E \sin \delta$ ,  $H = B_E \cos \delta$   
(2)  $V = B_E \cos \delta$ ,  $H = B_E \sin \delta$   
(3)  $V = B_E$ ,  $H = B_E \tan \delta$   
(4)  $V = B_E \tan \delta$ ,  $H = B_E$

Answer (1)

Sol.  $H = B_E \cos \delta$

$$V = B_E \sin \delta$$

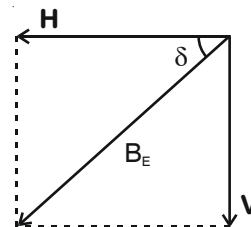

112. An object kept in a large room having air temperature of  $25^\circ\text{C}$  takes 12 minutes to cool from  $80^\circ\text{C}$  to  $70^\circ\text{C}$ .

The time taken to cool for the same object from  $70^\circ\text{C}$  to  $60^\circ\text{C}$  would be nearly,

- (1) 12 min                      (2) 20 min  
(3) 15 min                      (4) 10 min

**Answer (3)**

**Sol.** Using average method in Newton's law of cooling

$$\frac{(T_1 - T_2)}{t} = K \left( \frac{T_1 + T_2}{2} - T_0 \right)$$

$$\frac{(80 - 70)}{12} = K(75 - 25) \quad \dots(i)$$

$$\frac{(70 - 60)}{t'} = K(65 - 25) \quad \dots(ii)$$

Divide eq. (i) by (ii)

$$t' = 12 \times \frac{5}{4} = 15 \text{ min}$$

113. Two small spherical metal balls, having equal masses, are made from materials of densities  $\rho_1$  and  $\rho_2$  ( $\rho_1 = 8\rho_2$ ) and have radii of 1 mm and 2 mm, respectively, they are made to fall vertically (from rest) in a viscous medium whose coefficient of viscosity equals  $\eta$  and whose density is  $0.1\rho_2$ . The ratio of their terminal velocities would be,

(1)  $\frac{19}{36}$

(2)  $\frac{39}{72}$

(3)  $\frac{79}{36}$

(4)  $\frac{79}{72}$

**Answer (3)**

**Sol.** As  $V_T = \frac{2a^2}{9\eta}(\rho - \sigma)g$

$$V_{T1} = \frac{2 \times (1)^2}{9\eta}(\rho_1 - 0.1\rho_2)g$$

$$V_{T1} = \frac{2 \times 1}{9\eta}(8\rho_2 - 0.1\rho_2)g \quad \dots(i)$$

$$V_{T2} = \frac{2 \times (2)^2}{9\eta}(\rho_2 - 0.1\rho_2)g \quad \dots(ii)$$

$$\therefore \frac{V_{T1}}{V_{T2}} = \frac{7.9}{4(0.9)} = \frac{79}{36}$$

114. A particle starting from rest, moves in a circle of radius 'r'. It attains a velocity of  $V_0$  m/s in the  $n^{\text{th}}$  round. Its angular acceleration will be,

(1)  $\frac{V_0^2}{2\pi nr^2} \text{ rad/s}^2$       (2)  $\frac{V_0^2}{4\pi nr^2} \text{ rad/s}^2$

(3)  $\frac{V_0^2}{4\pi nr} \text{ rad/s}^2$       (4)  $\frac{V_0}{n} \text{ rad/s}^2$

**Answer (2)**

**Sol.** Initial speed = 0

Final speed =  $V_0$

Tangential acceleration =  $\alpha r$

$$V^2 = u^2 + 2as$$

$$V_0^2 = 0 + 2r\alpha(2\pi r)n$$

$$\alpha = \frac{V_0^2}{4\pi nr^2}$$

115. A person standing on the floor of an elevator drops a coin. The coin reaches the floor in time  $t_1$  if the elevator is at rest and in time  $t_2$  if the elevator is moving uniformly. Then

(1)  $t_1 < t_2$

(2)  $t_1 > t_2$

(3)  $t_1 = t_2$

(4)  $t_1 < t_2$  or  $t_1 > t_2$  depending upon whether the lift is going up or down

**Answer (3)**

**Sol.** In both case elevator is an inertial frame of reference so effective gravity remains same from both the frames.

So, time of fall remains same in both cases (since initial velocity is same in both frames).

Hence  $t_1 = t_2$

116. A truck is stationary and has a bob suspended by a light string, in a frame attached to the truck. The truck suddenly moves to the right with an acceleration of  $a$ . The pendulum will tilt

(1) to the left and angle of inclination of the pendulum with the vertical is  $\tan^{-1}\left(\frac{a}{g}\right)$

(2) to the left and angle of inclination of the pendulum with the vertical is  $\sin^{-1}\left(\frac{a}{g}\right)$

(3) to the left and angle of inclination of the pendulum with the vertical is  $\tan^{-1}\left(\frac{g}{a}\right)$

(4) to the left and angle of inclination of the pendulum with the vertical is  $\sin^{-1}\left(\frac{g}{a}\right)$

**Answer (1)**

**Sol.** From the frame of truck

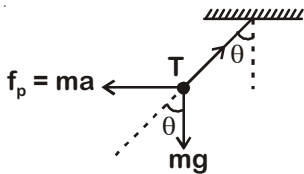

$$T \sin \theta = ma$$

$$T \cos \theta = mg$$

$$\tan \theta = \frac{a}{g}$$

$$\theta = \tan^{-1} \left( \frac{a}{g} \right)$$

117. A body of mass  $m$  is kept on a rough horizontal surface (coefficient of friction  $= \mu$ ). A horizontal force is applied on the body, but it does not move. The resultant of normal reaction and the frictional force acting on the object is given by  $F$ , where  $F$  is,

- (1)  $|\vec{F}| = \mu mg$                       (2)  $|\vec{F}| \leq mg\sqrt{1+\mu^2}$   
 (3)  $|\vec{F}| = mg$                         (4)  $|\vec{F}| = mg + \mu mg$

**Answer (2)**

**Sol.** Since body does not move hence it is in equilibrium.

$f_r$  = frictional force which is less than or equal to limiting friction.

Now  $N = mg$

Hence  $\vec{F} = \vec{N} + \vec{f}_r$

$$|\vec{F}| \leq (mg)^2 + (\mu mg)^2$$

$$|\vec{F}| \leq mg\sqrt{1+\mu^2}$$

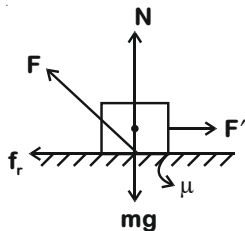

118. A particle of mass  $5m$  at rest suddenly breaks on its own into three fragments. Two fragments of mass  $m$  each move along mutually perpendicular direction with speed  $v$  each. The energy released during the process is,

- (1)  $\frac{5}{3}mv^2$                               (2)  $\frac{3}{2}mv^2$   
 (3)  $\frac{4}{3}mv^2$                               (4)  $\frac{3}{5}mv^2$

**Answer (3)**

**Sol.** From conservation of linear momentum.

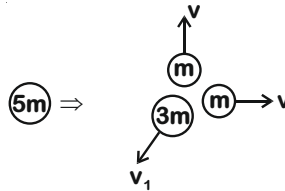

$$0 = mv\hat{j} + mv\hat{i} + 3m\vec{v}_1$$

$$\vec{v}_1 = -\frac{v}{3}(\hat{i} + \hat{j})$$

$$v_1 = \frac{\sqrt{2}}{3}v$$

$$KE_i = 0$$

$$KE_f = \frac{1}{2}mv^2 + \frac{1}{2}mv^2 + \frac{1}{2}(3m)\left(\frac{\sqrt{2}}{3}\right)^2 v^2$$

$$= mv^2 + \frac{mv^2}{3}$$

$$= \frac{4}{3}mv^2$$

$$\Delta KE = KE_f - KE_i = \frac{4}{3}mv^2$$

119. An object of mass 500 g, initially at rest, is acted upon by a variable force whose X-component varies with X in the manner shown. The velocities of the object at the points  $X = 8$  m and  $X = 12$  m, would have the respective values of (nearly)

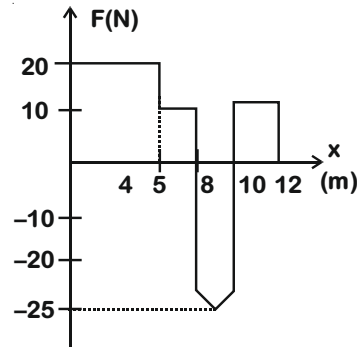

- (1) 23 m/s and 24.4 m/s  
 (2) 23 m/s and 20.6 m/s  
 (3) 18 m/s and 20.6 m/s  
 (4) 18 m/s and 24.4 m/s

**Answer (2)**

Sol.

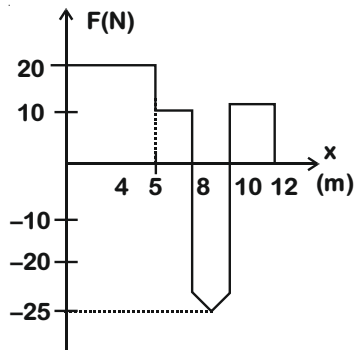

From work-energy theorem

$$\Delta K = \text{work} = \text{area under } F - x \text{ graph}$$

From  $x = 0$  to  $x = 8$  m

$$\frac{1}{2}mv^2 = 100 + 30$$

$$v^2 = 520$$

$$v = \sqrt{520} \approx 23 \text{ m/s}$$

From  $x = 0$  to  $x = 12$  m

$$\frac{1}{2}mv^2 = 100 + 30 - 47.5 + 20$$

$$v = \sqrt{410}$$

$$v \approx 20.6 \text{ m/s}$$

Hence appropriate option is 23 m/s and 20.6 m/s

120. A solid cylinder of mass 2 kg and radius 50 cm rolls up an inclined plane of angle of inclination  $30^\circ$ . The centre of mass of the cylinder has speed of 4 m/s. The distance travelled by the cylinder on the inclined surface will be, [take  $g = 10 \text{ m/s}^2$ ]

- (1) 1.6 m                      (2) 1.2 m  
(3) 2.4 m                      (4) 2.2 m

**Answer (3)**

Sol. Since  $v = \sqrt{\frac{2gh}{1 + \frac{K^2}{R^2}}}$

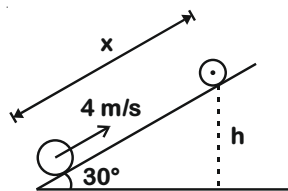

$$v^2 = \frac{2gh}{1 + \frac{1}{2}} \left[ \frac{K^2}{R^2} = \frac{1}{2} \text{ for solid cylinder} \right]$$

$$2gh = 4^2 \times \frac{3}{2}$$

$$h = \frac{12}{10} = 1.2 \text{ m}$$

$$\text{Now } x = \frac{h}{\sin 30^\circ} = \frac{1.2}{\frac{1}{2}} = 2.4 \text{ m}$$

$$x = 2.4 \text{ m}$$

121. Two toroids 1 and 2 have total no. of turns 200 and 100 respectively with average radii 40 cm and 20 cm respectively. If they carry same current  $i$ , the ratio of the magnetic fields along the two loops is,

- (1) 4 : 1                      (2) 2 : 1  
(3) 1 : 2                      (4) 1 : 1

**Answer (4)**

Sol. Magnetic field inside a toroid in

$$B = \frac{\mu_0 N \cdot I}{2\pi R}$$

$$\text{Here, } \frac{B_1}{B_2} = \frac{N_1 R_2}{N_2 R_1} = \frac{200 \cdot 20}{100 \cdot 40} = 1$$

$$\text{So, } \frac{B_1}{B_2} = 1$$

122. A straight conductor carrying current  $i$  splits into two parts as shown in the figure. The radius of the circular loop is  $R$ . The total magnetic field at the centre  $P$  of the loop is,

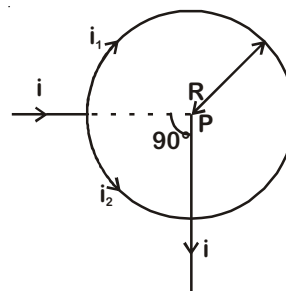

- (1)  $3\mu_0 i/32R$ , outward    (2)  $3\mu_0 i/32R$ , inward  
(3)  $\frac{\mu_0 i}{2R}$ , inward              (4) Zero

**Answer (4)**

Sol.

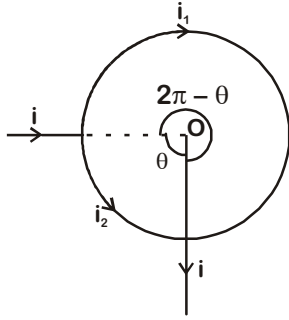

Net magnetic field at point 'P'

$$\vec{B}_{\text{net}} = \vec{B}_1 + \vec{B}_2$$

Here  $\vec{B}_1$  and  $\vec{B}_2$  are equal in magnitude and opposite in direction.

Hence,  $B_{\text{net}} = B_1 - B_2$

$$i_1 = i \left( \frac{\theta}{2\pi} \right) \Rightarrow B_1 = \frac{\mu_0 i_1}{2R} \left( \frac{2\pi - \theta}{2\pi} \right)$$

$$i_2 = i \left( \frac{2\pi - \theta}{2\pi} \right) \Rightarrow B_2 = \frac{\mu_0 i_2}{2R} \left( \frac{\theta}{2\pi} \right)$$

$$B_{\text{net}} = B_1 - B_2 = 0$$

123. The variation of EMF with time for four types of generators are shown in the figures. Which amongst them can be called AC?

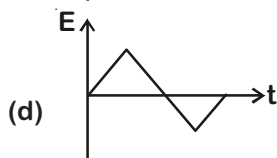
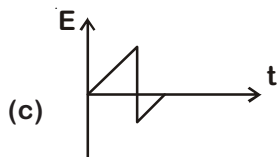
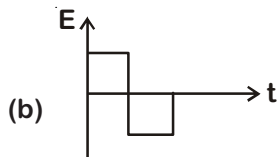
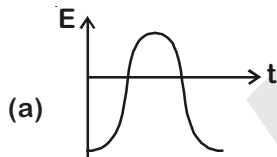

- (1) (a), (b), (c), (d)      (2) (a) and (b)  
(3) Only (a)                      (4) (a) and (d)

Answer (1)

Sol. A current which changes its direction periodically is called alternating current. Hence given all options are AC.

124. An equiconvex lens has power P. It is cut into two symmetrical halves by a plane containing the principal axis. The power of one part will be,

- (1)  $\frac{P}{2}$   
(2)  $\frac{P}{4}$   
(3) P  
(4) 0

Answer (3)

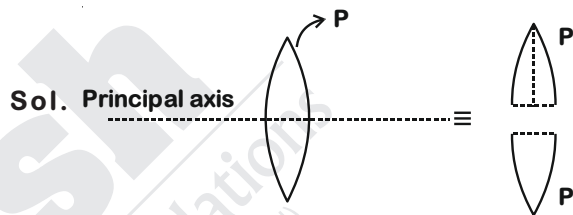

If lens is cut in two half as shown in the figure, then power of one part will be same. i.e. P, as focal length remains same.

125. In a Young's double slit experiment, if there is no initial phase difference between the light from the two slits, a point on the screen corresponding to the fifth minimum has path difference

- (1)  $10 \frac{\lambda}{2}$   
(2)  $9 \frac{\lambda}{2}$   
(3)  $11 \frac{\lambda}{2}$   
(4)  $5 \frac{\lambda}{2}$

Answer (2)

Sol. Path difference for destructive interference in YDSE

$$\Rightarrow \Delta X_n = \frac{(2n-1)\lambda}{2} \quad n = 1, 2, 3 \dots$$

$$\Delta X_{5^{\text{th}}} = \left( \frac{2 \times 5 - 1}{2} \right) \lambda = \frac{9\lambda}{2}$$

126. A double convex lens has focal length 25 cm. The radius of curvature of one of the surfaces is double of the other. Find the radii if the refractive index of the material of the lens is 1.5.

- (1) 25 cm, 50 cm
- (2) 18.75 cm, 37.5 cm
- (3) 50 cm, 100 cm
- (4) 100 cm, 50 cm

Answer (2)

Sol. Focal length of lens is  $\frac{1}{f} = (\mu - 1) \left( \frac{1}{R_1} - \frac{1}{R_2} \right)$

$$\frac{1}{25} = (1.5 - 1) \left( \frac{1}{R} + \frac{1}{2R} \right)$$

$$\frac{1}{25} = 0.5 \left( \frac{3}{2R} \right)$$

$$2R = 37.5 \text{ cm}$$

$$R = 18.75 \text{ cm}$$

Hence radii are 18.75 cm, 37.5 cm

127. Two bullets are fired horizontally and simultaneously towards each other from roof tops of two buildings 100 m apart and of same height of 200 m, with the same velocity of 25 m/s. When and where will the two bullets collide? ( $g = 10 \text{ m/s}^2$ )

- (1) After 2 s at a height of 20 m
- (2) After 4 s at a height of 120 m
- (3) They will not collide
- (4) After 2 s at a height of 180 m

Answer (4)

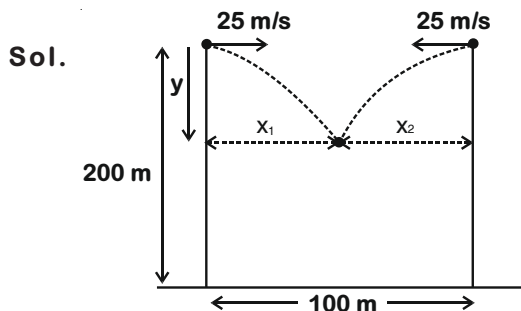

Let bullets collide at time  $t$

$$x_1 + x_2 = 100 \text{ m}$$

$$25t + 25t = 100$$

$$t = 2 \text{ sec}$$

$$y = \frac{1}{2}gt^2 = \frac{1}{2} \times 10 \times 2^2$$

$$= 20 \text{ m}$$

$$h = 200 - 20 = 180 \text{ m}$$

Hence bullets will collide after 2 s at height 180 m above the ground.

128. The stress-strain curves are drawn for two different materials X and Y. It is observed that the ultimate strength point and the fracture point are close to each other for material X but are far apart for material Y.

We can say that materials X and Y are likely to be (respectively),

- (1) Brittle and ductile
- (2) Brittle and plastic
- (3) Plastic and ductile
- (4) Ductile and brittle

Answer (1)

Sol. As given that fracture point and ultimate strength point is close for material X, hence X is brittle in nature and both points are far apart for material Y hence it is ductile.

i.e X is brittle and Y is ductile in nature.

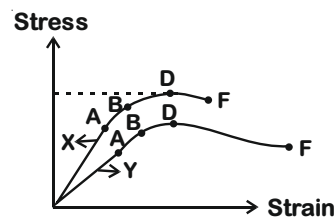

129. The rate of radioactive disintegration at an instant for a radioactive sample of half life  $2.2 \times 10^9 \text{ s}$  is  $10^{10} \text{ s}^{-1}$ . The number of radioactive atoms in that sample at that instant is,

- (1)  $3.17 \times 10^{17}$
- (2)  $3.17 \times 10^{18}$
- (3)  $3.17 \times 10^{19}$
- (4)  $3.17 \times 10^{20}$

**Answer (3)**

$$\text{Sol. } T_{1/2} = \frac{\ln 2}{\lambda} = \frac{0.693}{\lambda}$$

$$2.2 \times 10^9 = \frac{0.693}{\lambda}$$

$$\lambda = \frac{0.693}{2.2 \times 10^9} = 3.15 \times 10^{-10}$$

$$R = \lambda N \quad (R \text{ is activity})$$

$$N = \frac{R}{\lambda} = \frac{10^{10}}{3.15 \times 10^{-10}} = 3.17 \times 10^{19}$$

130. The time period of a geostationary satellite is 24 h, at a height  $6R_E$  ( $R_E$  is radius of earth) from surface of earth. The time period of another satellite whose height is  $2.5 R_E$  from surface will be,

(1)  $12\sqrt{2}$  h

(2)  $\frac{24}{2.5}$  h

(3)  $\frac{12}{2.5}$  h

(4)  $6\sqrt{2}$  h

**Answer (4)**

$$\text{Sol. } T^2 \propto r^3$$

$$T^2 \propto (R_E + h)^3$$

$$\frac{T_1^2}{T_2^2} = \frac{(R_E + 6R_E)^3}{(R_E + 2.5R_E)^3}$$

$$\frac{T_1^2}{T_2^2} = \frac{7^3}{\left(\frac{7}{2}\right)^3}$$

$$\frac{T_1^2}{T_2^2} = 8$$

$$T_2 = \frac{T_1}{2\sqrt{2}}$$

$$T_2 = \frac{24}{2\sqrt{2}}$$

$$T_2 = 6\sqrt{2} \text{ h}$$

131. A circuit when connected to an AC source of 12 V gives a current of 0.2 A. The same circuit when connected to a DC source of 12 V, gives a current of 0.4 A. The circuit is

(1) Series RC

(2) Series LC

(3) Series LCR

(4) Series LR

**Answer (4)**

$$\text{Sol. } I_1 = \frac{V}{Z}$$

$$I_1 = \frac{12}{\sqrt{R^2 + (X_L - X_C)^2}} = 0.2 \text{ A}$$

In second case for DC source, capacitor would provide infinite resistance but current is present in circuit, it means resistor and inductor can be present in the circuit.

As the current with AC source and DC source are different, inductor must be present with resistance.

132. A cycle wheel of radius 0.5 m is rotated with constant angular velocity of 10 rad/s in a region of magnetic field of 0.1 T which is perpendicular to the plane of the wheel. The EMF generated between its centre and the rim is,

(1) 0.125 V

(2) 0.5 V

(3) Zero

(4) 0.25 V

**Answer (1)**

$$\text{Sol. } \begin{matrix} \times & \times & \times & \times & \times & \times \\ \times & \times & \times & \times & \times & \times \\ \times & \times & \times & \times & \times & \times \\ \times & \times & \times & \times & \times & \times \end{matrix}$$

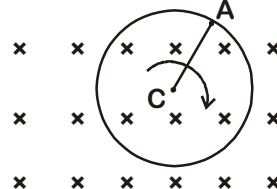

$$e = \frac{B l^2 \omega}{2}$$

$$= \frac{1}{2} \times 0.1 \times \left(\frac{1}{2}\right)^2 \times 10$$

$$= \frac{1}{8}$$

$$= 0.125 \text{ V}$$

133. For a transparent medium, relative permeability and permittivity,  $\mu_r$  and  $\epsilon_r$  are 1.0 and 1.44 respectively. The velocity of light in this medium would be,

- (1)  $3 \times 10^8$  m/s
- (2)  $2.08 \times 10^8$  m/s
- (3)  $4.32 \times 10^8$  m/s
- (4)  $2.5 \times 10^8$  m/s

Answer (4)

$$\begin{aligned} \text{Sol. } v &= \frac{1}{\sqrt{\mu\epsilon}} = \frac{c}{\sqrt{\mu_r \epsilon_r}} \\ &= \frac{3 \times 10^8}{\sqrt{1 \times 1.44}} \\ &= 2.5 \times 10^8 \text{ m/s} \end{aligned}$$

134. A sphere encloses an electric dipole with charges  $\pm 3 \times 10^{-6}$  C. What is the total electric flux across the sphere?

- (1) Zero
- (2)  $3 \times 10^{-6}$  Nm<sup>2</sup>/C
- (3)  $6 \times 10^{-6}$  Nm<sup>2</sup>/C
- (4)  $-3 \times 10^{-6}$  Nm<sup>2</sup>/C

Answer (1)

$$\text{Sol. } \phi_{\text{Total}} = \frac{q_{\text{enclosed}}}{\epsilon_0}$$

Dipole have equal and opposite charge, so net charge inside the sphere will be zero ( $q_{\text{enclosed}} = 0$ )

$$\begin{aligned} \phi_{\text{Total}} &= \frac{0}{\epsilon_0} \\ &= 0 \end{aligned}$$

135. Two identical capacitors  $C_1$  and  $C_2$  of equal capacitance are connected as shown in the circuit. Terminals a and b of the key k are connected to charge capacitor  $C_1$  using battery of emf  $V$  volt. Now disconnecting a and b the terminals b and c are connected. Due to this, what will be the percentage loss of energy?



- (1) 0%
- (2) 50%
- (3) 25%
- (4) 75%

Answer (2)

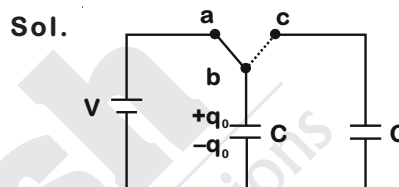

Sol.

$$U_i = \frac{1}{2} CV^2$$

On switching key at point c

$$\frac{q_0 - q}{C} = \frac{q}{C}$$

$$2q = q_0$$

$$q = \left(\frac{q_0}{2}\right)$$

$$U_f = \frac{1}{2} \left(\frac{q_0}{2}\right)^2 \times \frac{1}{C} + \frac{1}{2} \left(\frac{q_0}{2}\right)^2 \times \frac{1}{C}$$

$$U_f = \frac{q_0^2}{4C}$$

$$U_f = \frac{1}{4} CV^2$$

$$\text{loss} = \left(\frac{U_i - U_f}{U_i}\right) \times 100$$

$$\begin{aligned} &= \frac{\left(\frac{1}{2} - \frac{1}{4}\right) CV^2}{\frac{1}{2} CV^2} \times 100 \\ &= 50\% \end{aligned}$$

136. Match the oxide given in column A with its property given in column B

Column-A	Column-B
(i) $\text{Na}_2\text{O}$	(a) Neutral
(ii) $\text{Al}_2\text{O}_3$	(b) Basic
(iii) $\text{N}_2\text{O}$	(c) Acidic
(iv) $\text{Cl}_2\text{O}_7$	(d) Amphoteric

Which of the following options has all correct pairs?

- (1) (i)-(c), (ii)-(b), (iii)-(a), (iv)-(d)  
 (2) (i)-(a), (ii)-(d), (iii)-(b), (iv)-(c)  
 (3) (i)-(b), (ii)-(d), (iii)-(a), (iv)-(c)  
 (4) (i)-(b), (ii)-(a), (iii)-(d), (iv)-(c)

Answer (3)

Sol.  $\text{Na}_2\text{O}$  is basic oxide  $\Rightarrow$  (i) - (b)  
 $\text{Al}_2\text{O}_3$  is amphoteric oxide  $\Rightarrow$  (ii) - (d)  
 $\text{N}_2\text{O}$  is neutral  $\Rightarrow$  (iii) - (a)  
 $\text{Cl}_2\text{O}_7$  is acidic oxide  $\Rightarrow$  (iv) - (c)

137. Match the catalyst with the process

Catalyst	Process
(i) $\text{V}_2\text{O}_5$	(a) The oxidation of ethyne to ethanal
(ii) $\text{TiCl}_4 + \text{Al}(\text{CH}_3)_3$	(b) Polymerisation of alkynes
(iii) $\text{PdCl}_2$	(c) Oxidation of $\text{SO}_2$ in the manufacture of $\text{H}_2\text{SO}_4$
(iv) Nickel complexes	(d) Polymerisation of ethylene

Which of the following is the correct option?

- (1) (i)-(a), (ii)-(b), (iii)-(c), (iv)-(d)  
 (2) (i)-(a), (ii)-(c), (iii)-(b), (iv)-(d)  
 (3) (i)-(c), (ii)-(a), (iii)-(d), (iv)-(b)  
 (4) (i)-(c), (ii)-(d), (iii)-(a), (iv)-(b)

Answer (4)

Sol. (i)  $\text{V}_2\text{O}_5$  : Used in the oxidation of  $\text{SO}_2$  in the manufacture of  $\text{H}_2\text{SO}_4$ .  
 (ii)  $\text{TiCl}_4 + \text{Al}(\text{CH}_3)_3$  : Used in the polymerisation of ethylene  
 (iii)  $\text{PdCl}_2$  : Used in the oxidation of ethyne to ethanal  
 (iv) Nickel Complex : Used in the polymerisation of alkynes

138. The most stable carbocation, among the following, is

- (1)  $\text{CH}_3 - \text{CH}_2 - \overset{\oplus}{\text{C}}\text{H} - \text{CH}_2 - \text{CH}_3$   
 (2)  $\text{CH}_3 - \overset{\oplus}{\text{C}}\text{H} - \text{CH}_2 - \text{CH}_2 - \text{CH}_3$   
 (3)  $\text{CH}_3 - \text{CH}_2 - \overset{\oplus}{\text{C}}\text{H}_2$   
 (4)  $(\text{CH}_3)_3\text{C} - \overset{\oplus}{\text{C}}\text{H} - \text{CH}_3$

Answer (2)

Sol. Stability of carbocation depends upon number of  $\alpha$ -H because of +H effect i.e. hyperconjugation effect.

Among the given carbocations,

$\overset{\alpha\text{-H}}{\text{CH}_3} - \overset{\oplus}{\text{C}}\text{H} - \overset{\alpha\text{-H}}{\text{CH}_2} - \text{CH}_2 - \text{CH}_3$  is the most stable carbocation because number of  $\alpha$ -H is maximum (5  $\alpha$ -H)

139. The alkane that gives only one mono-chloro product on chlorination with  $\text{Cl}_2$  in presence of diffused sunlight is

- (1) neopentane  
 (2) n-pentane  
 (3) Isopentane  
 (4) 2, 2-dimethylbutane

Answer (1)

Sol. Chlorination of neopentane with  $\text{Cl}_2$  in the presence of diffused sunlight gives only one mono-chloro compound.

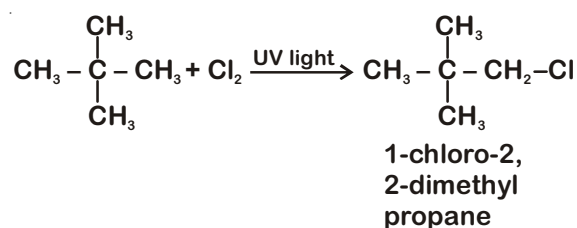

140. In the following reaction,

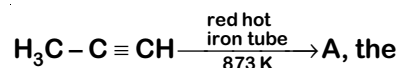

number of sigma ( $\sigma$ ) bonds present in the product A, is

- (1) 9 (2) 24  
 (3) 18 (4) 21

Answer (4)

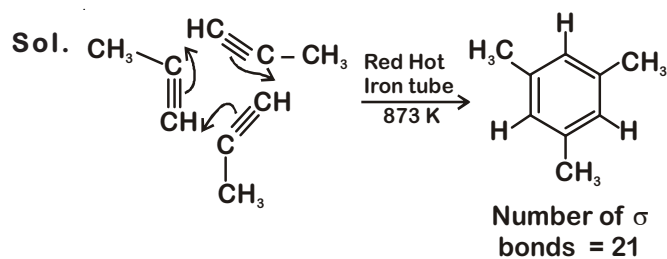

141. The reaction that does not give benzoic acid as the major product is

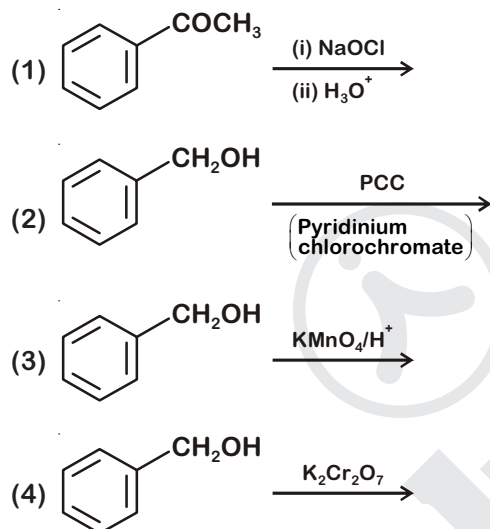

Answer (2)

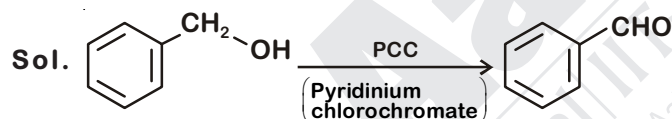

PCC oxidises primary alcohol to aldehyde.

142. The amine that reacts with Hinsberg's reagent to give an alkali insoluble product is

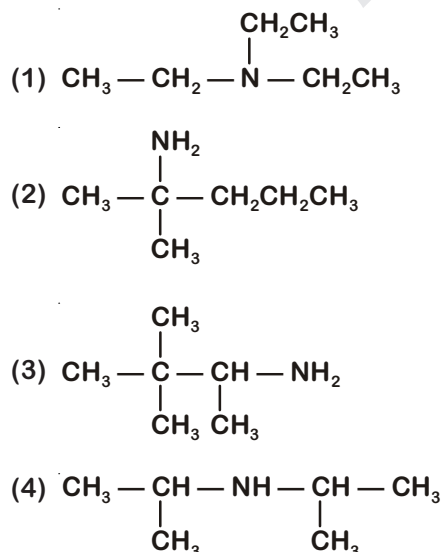

Answer (4)

Sol. Secondary amines react with Hinsberg's reagent to give a product which is insoluble in alkali.

143. Which structure(s) of proteins remain(s) intact during denaturation process?

- (1) Primary structure only  
(2) Secondary structure only  
(3) Tertiary structure only  
(4) Both secondary and tertiary structures

Answer (1)

Sol. During denaturation primary structure of proteins remain intact.

144. The polymer that is used as a substitute for wool in making commercial fibres is

- (1) nylon-6,6                      (2) polyacrylonitrile  
(3) Buna-N                        (4) melamine

Answer (2)

Sol. Polyacrylonitrile is used as a substitute for wool in making commercial fibre as orlon or acrilan.

145. The artificial sweetener stable at cooking temperature and does not provide calories is

- (1) aspartame                      (2) sucralose  
(3) alitame                        (4) saccharin

Answer (2)

Sol. Sucralose is trichloro derivative of sucrose. It is stable at cooking temperature. It does not provide calories.

146. The density of 2 M aqueous solution of NaOH is  $1.28 \text{ g/cm}^3$ . The molality of the solution is [Given that molecular mass of NaOH =  $40 \text{ g mol}^{-1}$ ]

- (1) 1.56 m                        (2) 1.67 m  
(3) 1.32 m                        (4) 1.20 m

Answer (2)

Sol. Let, volume of solution = 1 litre

Mole of NaOH = 2

Mass of NaOH solution =  $1000 \times 1.28 = 1280 \text{ g}$

Mass of  $\text{H}_2\text{O} = (1280 - 2 \times 40) = 1200 \text{ g} = 1.2 \text{ kg}$

$$\text{Molality (m)} = \frac{\text{Mole of NaOH}}{\text{Mass of solvent (kg)}}$$

$$= \frac{2}{1.2}$$

$$= 1.67 \text{ m}$$



$$= \lambda_m^{\circ}(\text{CH}_3\text{COOK}) + \frac{1}{2}\lambda_m^{\circ}(\text{H}_2\text{SO}_4) - \frac{1}{2}\lambda_m^{\circ}(\text{K}_2\text{SO}_4)$$

$$= z + \frac{x}{2} - \frac{y}{2}$$

$$= z + \left(\frac{x-y}{2}\right)$$

153. A first order reaction has a rate constant of  $2.303 \times 10^{-3} \text{ s}^{-1}$ . The time required for 40 g of this reactant to reduce to 10 g will be

[Given that  $\log_{10} 2 = 0.3010$ ]

- (1) 301 s                      (2) 2000 s  
(3) 602 s                      (4) 230.3 s

**Answer (3)**

**Sol.** For a first order reaction

$$\text{Half life period, } t_{1/2} = \frac{0.693}{k} = \frac{0.693}{2.303 \times 10^{-3}} \text{ s}^{-1}$$

$$= 300.91 \text{ s}$$

Now,  $40 \text{ g} \xrightarrow{t_{1/2}} 20 \text{ g} \xrightarrow{t_{1/2}} 10 \text{ g}$

So, 40 g substance requires 2 half life periods to reduce upto 10 g

$$\therefore \text{Time taken in reduction} = 2 \times 300.91 \text{ s}$$

$$= 601.82$$

$$\approx 602 \text{ s}$$

154. For a reaction, activation energy  $E_a = 0$  and the rate constant at 200 K is  $1.6 \times 10^6 \text{ s}^{-1}$ . The rate constant at 400 K will be

[Given that gas constant,  $R = 8.314 \text{ J K}^{-1} \text{ mol}^{-1}$ ]

- (1)  $1.6 \times 10^6 \text{ s}^{-1}$   
(2)  $1.6 \times 10^3 \text{ s}^{-1}$   
(3)  $3.2 \times 10^6 \text{ s}^{-1}$   
(4)  $3.2 \times 10^4 \text{ s}^{-1}$

**Answer (1)**

**Sol.** From Arrhenius equation

$$\log \frac{k_{400}}{k_{200}} = \frac{E_a}{2.303 R} \left[ \frac{T_2 - T_1}{T_1 T_2} \right]$$

Since, given that  $E_a = 0$

$$\therefore \log \frac{k_{400}}{k_{200}} = 0 \Rightarrow \frac{k_{400}}{k_{200}} = 1$$

So,  $k_{400} = k_{200}$

So rate constant at 400 k =  $1.6 \times 10^6 \text{ s}^{-1}$

155. The correct option representing a Freundlich adsorption isotherm is

- (1)  $\frac{x}{m} = kp^{2.5}$                       (2)  $\frac{x}{m} = kp^{-0.5}$   
(3)  $\frac{x}{m} = kp^{-1}$                       (4)  $\frac{x}{m} = kp^{0.3}$

**Answer (4)**

**Sol.** According to Freundlich isotherm

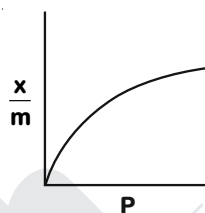

$$\frac{x}{m} = KP^{1/n}$$

( $n > 1$ )

$$\text{So, } \frac{x}{m} = KP^{0.3} \text{ as } \frac{1}{n} = 0.3$$

So, Answer is (2).

156. Which of the following is paramagnetic?

- (1)  $\text{H}_2$                                       (2)  $\text{Li}_2$   
(3)  $\text{O}_2$                                       (4)  $\text{N}_2$

**Answer (3)**

**Sol.**  $\text{O}_2$  has  $8 + 8 = 16$  electrons, so distribution of electrons in MO (molecular orbitals) follows the order as

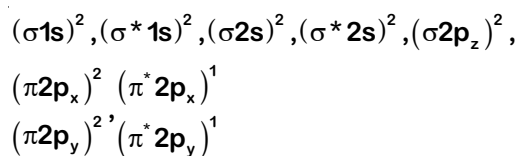

So, in  $\text{O}_2$  molecule, there are two (2) unpaired electrons, so, it is a "paramagnetic" substance in nature.

157. Which of the following is the correct order of dipole moment?

- (1)  $\text{BF}_3 < \text{NF}_3 < \text{NH}_3 < \text{H}_2\text{O}$   
(2)  $\text{BF}_3 < \text{NH}_3 < \text{NF}_3 < \text{H}_2\text{O}$   
(3)  $\text{H}_2\text{O} < \text{NF}_3 < \text{NH}_3 < \text{BF}_3$   
(4)  $\text{NH}_3 < \text{BF}_3 < \text{NF}_3 < \text{H}_2\text{O}$

**Answer (1)**

**Sol.** Dipole moment of a molecule is the vector sum of dipoles of bonds. So based on molecular geometry of following molecules,

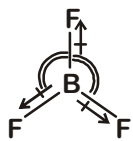

Three equal vectors at  $120^\circ$  has resultant = 0 so nonpolar molecule

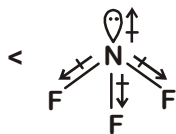

Vectors not aligned in the same direction of lone pair so less dipole moment

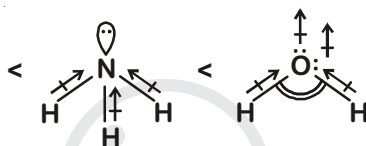

Vectors aligned in same direction of lone pair

Maximum dipole moment

158. Crude sodium chloride obtained by crystallisation of brine solution does not contain

- (1)  $\text{Na}_2\text{SO}_4$                       (2)  $\text{MgCl}_2$   
 (3)  $\text{CaSO}_4$                         (4)  $\text{MgSO}_4$

**Answer (4)**

**Sol.** Crude sodium chloride generally obtained by crystallisation of brine solution contains  $\text{Na}_2\text{SO}_4$ ,  $\text{CaSO}_4$ ,  $\text{CaCl}_2$  and  $\text{MgCl}_2$  as impurities.

159. Which of the alkali metal chloride (MCl) forms its dihydrate salt ( $\text{MCl} \cdot 2\text{H}_2\text{O}$ ) easily?

- (1) CsCl                              (2) RbCl  
 (3) KCl                                (4) LiCl

**Answer (4)**

**Sol.** Out of alkali metal chlorides only LiCl forms a dihydrate, other metal chlorides do not form hydrates.

160. The liquified gas that is used in dry cleaning along with a suitable detergent is

- (1) Petroleum gas      (2)  $\text{NO}_2$   
 (3)  $\text{CO}_2$                       (4) Water gas

**Answer (3)**

**Sol.** Liquified  $\text{CO}_2$  (carbon dioxide) with a suitable detergent is used in dry cleaning.

161. The hydrolysis reaction that takes place at the slowest rate, among the following is

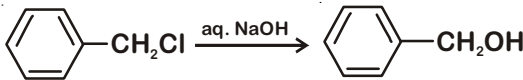
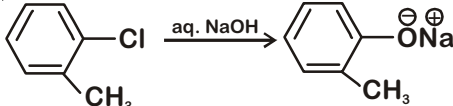
- (1)  $\text{H}_3\text{C}-\text{CH}_2-\text{Cl} \xrightarrow{\text{aq. NaOH}} \text{H}_3\text{C}-\text{CH}_2-\text{OH}$   
 (2)  $\text{H}_2\text{C}=\text{CH}-\text{CH}_2\text{Cl} \xrightarrow{\text{aq. NaOH}} \text{H}_2\text{C}=\text{CH}-\text{CH}_2\text{OH}$   
 (3)   
 (4) 

**Answer (4)**

**Sol.** Aryl halides do not give substitution reactions due to partial double bond character.

162. When vapours of a secondary alcohol is passed over heated copper at 573 K, the product formed is

- (1) an aldehyde                      (2) a ketone  
 (3) an alkene                        (4) a carboxylic acid

**Answer (2)**

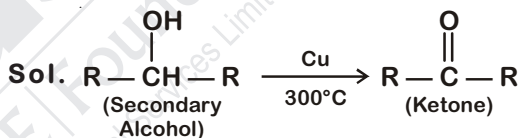

163. The major products C and D formed in the following reaction respectively are

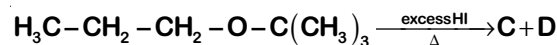

- (1)  $\text{H}_3\text{C}-\text{CH}_2-\text{CH}_2-\text{OH}$  and  $\text{I}-\text{C}(\text{CH}_3)_3$   
 (2)  $\text{H}_3\text{C}-\text{CH}_2-\text{CH}_2-\text{I}$  and  $\text{HO}-\text{C}(\text{CH}_3)_3$   
 (3)  $\text{H}_3\text{C}-\text{CH}_2-\text{CH}_2-\text{OH}$  and  $\text{HO}-\text{C}(\text{CH}_3)_3$   
 (4)  $\text{H}_3\text{C}-\text{CH}_2-\text{CH}_2-\text{I}$  and  $\text{I}-\text{C}(\text{CH}_3)_3$

**Answer (4)**

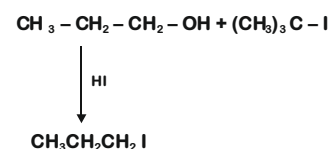
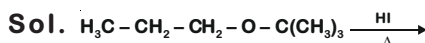

164. The pH of 0.01 M NaOH (aq) solution will be

- (1) 2                                      (2) 12  
 (3) 9                                      (4) 7.01

**Answer (2)**

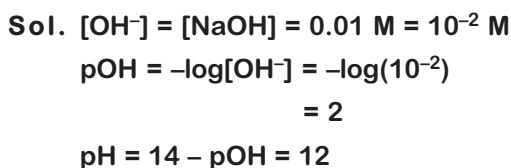

165. Which of the following cannot act both as Bronsted acid and as Bronsted base?

- (1)  $\text{NH}_3$  (2)  $\text{HCl}$   
(3)  $\text{HSO}_4^-$  (4)  $\text{HCO}_3^-$

Answer (2)

Sol. Substance which can release and accept  $\text{H}^+$  can act as both Bronsted base and acid.

$\text{HCl}$  cannot accept  $\text{H}^+$  therefore cannot act as Bronsted base.

166. The molar solubility of  $\text{CaF}_2$  ( $K_{sp} = 5.3 \times 10^{-11}$ ) in 0.1 M solution of  $\text{NaF}$  will be

- (1)  $5.3 \times 10^{-8} \text{ mol L}^{-1}$  (2)  $5.3 \times 10^{-9} \text{ mol L}^{-1}$   
(3)  $5.3 \times 10^{-10} \text{ mol L}^{-1}$  (4)  $5.3 \times 10^{-11} \text{ mol L}^{-1}$

Answer (2)

Sol.  $K_{sp}(\text{CaF}_2) = 5.3 \times 10^{-11}$

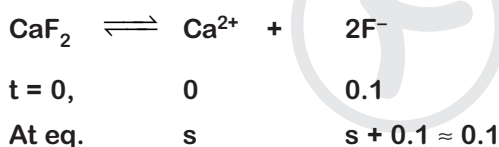

$$K_{sp} = [\text{Ca}^{2+}][\text{F}^-]^2 = (s)(0.1)^2$$

$$s = \frac{K_{sp}}{(0.1)^2} = \frac{5.3 \times 10^{-11}}{(0.1)^2} = 5.3 \times 10^{-9} \text{ mol L}^{-1}$$

167. The oxidation state of Cr in  $\text{CrO}_6$  is

- (1) +12 (2) +6  
(3) +4 (4) -6

Answer (2#)

Sol. The most appropriate oxidation state of Cr in  $\text{CrO}_6$  is +6 although  $\text{CrO}_6$  has doubtful existence.

168. The number of hydrogen bonded water molecule(s) associated with  $\text{CuSO}_4 \cdot 5\text{H}_2\text{O}$  is

- (1) 1 (2) 2  
(3) 5 (4) 3

Answer (1)

Sol. The actual structure of  $\text{CuSO}_4 \cdot 5\text{H}_2\text{O}$  is  $[\text{Cu}(\text{H}_2\text{O})_4]\text{SO}_4 \cdot \text{H}_2\text{O}$ , so only one water molecule is associated with the molecule via hydrogen bond.

169. Formula of nickel oxide with metal deficiency defect in its crystal is  $\text{Ni}_{0.98}\text{O}$ . The crystal contains  $\text{Ni}^{2+}$  and  $\text{Ni}^{3+}$  ions. The fraction of nickel existing as  $\text{Ni}^{2+}$  ions in the crystal is

- (1) 0.04 (2) 0.50  
(3) 0.31 (4) 0.96

Answer (4)

Sol.  $\text{Ni}_{0.98}\text{O} = (\text{Ni}^{2+})_x (\text{Ni}^{3+})_{0.98-x} (\text{O}^{2-})_1$

Net charge = 0

$$[x \times 2] + [(0.98 - x) \times 3] + [-2 \times 1] = 0$$

$$x = 0.94$$

Fraction of nickel existing as

$$\text{Ni}^{2+} = \frac{0.94}{0.98} = 0.959 \approx 0.96$$

170. Which of the following statements is correct regarding a solution of two components A and B exhibiting positive deviation from ideal behaviour?

- (1)  $\Delta_{\text{mix}}H = 0$  at constant T and P.  
(2)  $\Delta_{\text{mix}}V = 0$  at constant T and P.  
(3) Intermolecular attractive forces between A-A and B-B are equal to those between A-B.  
(4) Intermolecular attractive forces between A-A and B-B are stronger than those between A-B.

Answer (4)

Sol. Solution exhibiting positive deviation from ideal behaviour must have weaker A - B interactions than A - A and B - B interactions.

171. In water saturated air, the mole fraction of water vapour is 0.02. If the total pressure of the saturated air is 1.2 atm, the partial pressure of dry air is

- (1) 1.76 atm (2) 1.176 atm  
(3) 0.98 atm (4) 1.18 atm

Answer (2)

Sol. Mole fraction of water vapour = 0.02

$$\text{Mole fraction of dry air} = 1 - 0.02 = 0.98$$

$$\text{Total pressure of saturated air} = 1.2 \text{ atm}$$

Using Dalton's law of partial pressure,

$$P_{\text{Dry air}} = P_{\text{Total}} \times x_{\text{Dry air}} = 1.2 \times 0.98 = 1.176 \text{ atm}$$

172. The standard electrode potential ( $E^\ominus$ ) values of  $\text{Al}^{3+}/\text{Al}$ ,  $\text{Ag}^+/\text{Ag}$ ,  $\text{K}^+/\text{K}$  and  $\text{Cr}^{3+}/\text{Cr}$  are -1.66 V, 0.80 V, -2.93 V and -0.74 V, respectively. The correct decreasing order of reducing power of the metal is

- (1)  $\text{K} > \text{Al} > \text{Cr} > \text{Ag}$  (2)  $\text{K} > \text{Al} > \text{Ag} > \text{Cr}$   
(3)  $\text{Al} > \text{K} > \text{Ag} > \text{Cr}$  (4)  $\text{Ag} > \text{Cr} > \text{Al} > \text{K}$

Answer (1)

**Sol.** Lesser is the reduction potential greater is the reducing power.

Reduction Potential :  $\text{Ag}^+/\text{Ag} > \text{Cr}^{3+}/\text{Cr} > \text{Al}^{3+}/\text{Al} > \text{K}^+/\text{K}$

Reducing Power :  $\text{K} > \text{Al} > \text{Cr} > \text{Ag}$

173. Aluminium chloride in acidified aqueous solution forms a complex 'A', in which hybridisation state of Al is 'B'. What are 'A' and 'B', respectively?

- (1)  $[\text{Al}(\text{H}_2\text{O})_4]^{3+}$ ,  $sp^3$
- (2)  $[\text{Al}(\text{H}_2\text{O})_4]^{3+}$ ,  $dsp^2$
- (3)  $[\text{Al}(\text{H}_2\text{O})_6]^{3+}$ ,  $d^2sp^3$
- (4)  $[\text{Al}(\text{H}_2\text{O})_6]^{3+}$ ,  $sp^3d^2$

**Answer (4)**

**Sol.**  $\text{AlCl}_3 \xrightarrow{\text{Acidified aq. sol.}} [\text{Al}(\text{H}_2\text{O})_6]^{3+}$

$\therefore$  The hybridisation of Al is  $sp^3d^2$ .

174. Which of the following compounds is used in cosmetic surgery?

- (1) Silicates
- (2) Silicones
- (3) Zeolites
- (4) Silica

**Answer (2)**

**Sol.** Silicones are used in cosmetic surgery.

175. Identify the incorrect statement.

- (1) Minerals are naturally occurring chemical substances in the earth's crust
- (2) Ores are minerals that may contain a metal
- (3) Gangue is an ore contaminated with undesired materials
- (4) The scientific and technological process used for isolation of the metal from its ore is known as metallurgy

**Answer (3)**

**Sol.** Gangue is the earthly or undesired material which is contaminating the ore.

176. A compound 'X' upon reaction with  $\text{H}_2\text{O}$  produces a colorless gas 'Y' with rotten fish smell. Gas 'Y' is absorbed in a solution of  $\text{CuSO}_4$  to give  $\text{Cu}_3\text{P}_2$  as one of the products. Predict the compound 'X'.

- (1)  $\text{NH}_4\text{Cl}$
- (2)  $\text{As}_2\text{O}_3$
- (3)  $\text{Ca}_3(\text{PO}_4)_2$
- (4)  $\text{Ca}_3\text{P}_2$

**Answer (4)**

**Sol.**  $\text{Ca}_3\text{P}_2 + 6\text{H}_2\text{O} \longrightarrow 3\text{Ca}(\text{OH})_2 + 2\text{PH}_3$   
 (X) (Y)  
 (rotten fish smell)

$2\text{PH}_3 + 3\text{CuSO}_4 \longrightarrow \text{Cu}_3\text{P}_2 + 3\text{H}_2\text{SO}_4$   
 (Y)

177. Which of the following oxoacids of phosphorus has strongest reducing property?

- (1)  $\text{H}_3\text{PO}_3$
- (2)  $\text{H}_3\text{PO}_2$
- (3)  $\text{H}_3\text{PO}_4$
- (4)  $\text{H}_4\text{P}_2\text{O}_7$

**Answer (2)**

**Sol.** Hypophosphorous acid is a good reducing agent as it contains two P-H bonds.

$4\text{AgNO}_3 + 2\text{H}_2\text{O} + \text{H}_3\text{PO}_2 \longrightarrow 4\text{Ag} + 4\text{HNO}_3 + \text{H}_3\text{PO}_4$

178. Identify the correct formula of 'oleum' from the following.

- (1)  $\text{H}_2\text{SO}_3$
- (2)  $\text{H}_2\text{SO}_4$
- (3)  $\text{H}_2\text{S}_2\text{O}_8$
- (4)  $\text{H}_2\text{S}_2\text{O}_7$

**Answer (4)**

**Sol.** Oleum is ' $\text{H}_2\text{S}_2\text{O}_7$ '.

179. When neutral or faintly alkaline  $\text{KMnO}_4$  is treated with potassium iodide, iodide ion is converted into 'X'. 'X' is

- (1)  $\text{IO}_4^-$
- (2)  $\text{IO}_3^-$
- (3)  $\text{IO}^-$
- (4)  $\text{I}_2$

**Answer (2)**

**Sol.** In neutral or faintly alkaline solutions, iodide ion is converted into iodate.

$2\text{MnO}_4^- + \text{H}_2\text{O} + \text{I}^- \rightarrow 2\text{MnO}_2 + 2\text{OH}^- + \text{IO}_3^-$

180. The Crystal Field Stabilisation Energy (CFSE) for  $[\text{CoCl}_6]^{4-}$  is  $18000 \text{ cm}^{-1}$ . The CFSE for  $[\text{CoCl}_4]^{2-}$  will be

- (1)  $16000 \text{ cm}^{-1}$
- (2)  $18000 \text{ cm}^{-1}$
- (3)  $8000 \text{ cm}^{-1}$
- (4)  $6000 \text{ cm}^{-1}$

**Answer (3)**

**Sol.**  $\therefore \Delta_t = \frac{4}{9}\Delta_0$

$\Delta_t = \frac{4}{9} \times 18000 \text{ cm}^{-1} = 8000 \text{ cm}^{-1}$