

## All India Aakash Test Series for NEET - 2026

**TEST - 2 (Code-E)**[Click here for Code-F Sol.](#)

Test Date : 30/11/2025

**ANSWERS**

1. (3)	37. (2)	73. (3)	109. (2)	145. (3)
2. (4)	38. (3)	74. (1)	110. (1)	146. (4)
3. (3)	39. (3)	75. (2)	111. (2)	147. (1)
4. (4)	40. (3)	76. (1)	112. (2)	148. (3)
5. (2)	41. (2)	77. (4)	113. (2)	149. (4)
6. (2)	42. (4)	78. (3)	114. (4)	150. (2)
7. (4)	43. (2)	79. (2)	115. (2)	151. (1)
8. (1)	44. (3)	80. (2)	116. (2)	152. (4)
9. (1)	45. (4)	81. (4)	117. (3)	153. (4)
10. (4)	46. (3)	82. (4)	118. (4)	154. (3)
11. (1)	47. (1)	83. (1)	119. (1)	155. (3)
12. (2)	48. (4)	84. (3)	120. (1)	156. (3)
13. (3)	49. (4)	85. (2)	121. (2)	157. (2)
14. (4)	50. (1)	86. (2)	122. (4)	158. (4)
15. (2)	51. (3)	87. (2)	123. (4)	159. (4)
16. (2)	52. (3)	88. (3)	124. (1)	160. (3)
17. (4)	53. (1)	89. (4)	125. (1)	161. (4)
18. (3)	54. (3)	90. (2)	126. (3)	162. (2)
19. (1)	55. (3)	91. (3)	127. (3)	163. (2)
20. (3)	56. (4)	92. (1)	128. (4)	164. (3)
21. (1)	57. (3)	93. (3)	129. (1)	165. (1)
22. (3)	58. (3)	94. (2)	130. (3)	166. (2)
23. (4)	59. (3)	95. (4)	131. (3)	167. (3)
24. (4)	60. (4)	96. (4)	132. (2)	168. (4)
25. (2)	61. (3)	97. (3)	133. (1)	169. (4)
26. (2)	62. (2)	98. (3)	134. (1)	170. (1)
27. (2)	63. (4)	99. (4)	135. (3)	171. (1)
28. (1)	64. (3)	100. (1)	136. (3)	172. (1)
29. (4)	65. (1)	101. (2)	137. (1)	173. (3)
30. (3)	66. (2)	102. (3)	138. (3)	174. (3)
31. (2)	67. (3)	103. (3)	139. (2)	175. (2)
32. (2)	68. (1)	104. (4)	140. (1)	176. (3)
33. (1)	69. (1)	105. (2)	141. (4)	177. (1)
34. (1)	70. (1)	106. (3)	142. (1)	178. (1)
35. (4)	71. (2)	107. (2)	143. (1)	179. (3)
36. (3)	72. (4)	108. (4)	144. (1)	180. (3)

# HINTS & SOLUTIONS

## [PHYSICS]

1. Answer (3)

**Hint & Sol.:**  $\vec{P} + \vec{Q} = \vec{R}$

$$\vec{Q} = \vec{R} - \vec{P}$$

$$\vec{Q} \cdot \vec{Q} = \vec{R} \cdot \vec{Q} - \vec{P} \cdot \vec{Q}$$

$$Q^2 = \vec{R} \cdot \vec{Q} - \vec{P} \cdot \vec{Q}$$

$$Q = \sqrt{\vec{R} \cdot \vec{Q} - \vec{P} \cdot \vec{Q}}$$

2. Answer (4)

**Hint:** Apply  $F_{\text{net}} = 0$  in vertical direction.

**Sol.:**  $\because F_{\text{net}} = 0$  in vertical direction

$$\therefore T_2 \sin 37^\circ = 2g$$

$$T_2 \times \frac{3}{5} = 20$$

$$T_2 = \frac{100}{3} \text{ N}$$

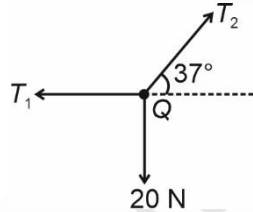

3. Answer (3)

**Hint:** Power is defined as rate of change of kinetic energy.

**Sol.:**  $P = \text{constant}$

$$\frac{dK}{dt} = \text{constant}$$

$$\therefore K \propto t$$

4. Answer (4)

**Hint & Sol.:** The collision in which the bodies stick together after collision is called perfectly inelastic collision, and in perfectly inelastic collision linear momentum of system is conserved.

5. Answer (2)

**Hint:** Use formula  $W = \vec{F} \cdot \vec{d}$

$$\text{Sol.} \quad \vec{d} = (5-2)\hat{i} + (1-3)\hat{j} + (3+4)\hat{k}$$

$$= (3\hat{i} - 2\hat{j} + 7\hat{k}) \text{ m}$$

$$\vec{F} = (2\hat{i} + 2\hat{j} - \hat{k}) \text{ N}$$

$$W = (2\hat{i} + 2\hat{j} - \hat{k}) \cdot (3\hat{i} - 2\hat{j} + 7\hat{k})$$

$$= 6 - 4 - 7 = -5 \text{ J}$$

6. Answer (2)

**Hint:** Use work-energy theorem.

**Sol.:**  $W_{\text{net}} = \Delta K$

$$\frac{1}{2}mv^2 = W_{mg} + W_F$$

$$v^2 = -20 \times 3 + 40 \times 4$$

$$v^2 = 160 - 60 = 100$$

$$v = 10 \text{ m/s}$$

7. Answer (4)

**Hint:**  $W_{\text{net}} = \Delta K$

**Sol.:**  $W_{\text{net}} = W_{mg} + W_{\text{air}}$

$$W_{mg} = 0$$

$|W_{\text{air}}| = \Delta K$

$$= \left| -\frac{1}{2}mv_i^2 + \frac{1}{2}mv_f^2 \right|$$

$$= \left| -\frac{1}{2}m(\sqrt{2gh})^2 + \frac{1}{2}m\left(\sqrt{\frac{2gh}{3}}\right)^2 \right|$$

$$= \left| -mgh + \frac{mgh}{3} \right|$$

$$= \frac{2mgh}{3}$$

8. Answer (1)

**Hint:** Use conservation of mechanical energy

**Sol.:**  $ME_i = ME_f$

$$\frac{1}{2}mv_0^2 = \frac{1}{2}m\left(\frac{v_0}{2}\right)^2 + \frac{1}{2}kx^2$$

$$\frac{3}{4}mv_0^2 = kx^2$$

$$x = \frac{v_0}{2} \sqrt{\frac{3m}{k}}$$

9. Answer (1)

**Hint & Sol:**  $P = \vec{F} \cdot \vec{v}$

$$P = Fv \cos 90^\circ = 0$$

10. Answer (4)

**Hint & Sol:** Potential energy is defined only for conservative force, it depends on reference point so it may be positive, negative or zero.

11. Answer (1)

**Hint:**  $W = \int \vec{F} \cdot d\vec{r}$

**Sol.:**  $\vec{F} = (2x\hat{i} + 2\hat{j}) \text{ N}$

$d\vec{r} = (dx\hat{i} + dy\hat{j}) \text{ m}$

$W = \int_1^3 2x \, dx + \int_2^4 2 \, dy$

$W = [x^2]_1^3 + [2y]_2^4$   
 $= (9 - 1) + (8 - 4) = 8 + 4 = 12 \text{ J}$

12. Answer (2)

**Hint:** Use formula  $W = \int P \, dt$

**Sol.:**  $W = \int P \, dt$

$= \int_1^3 (3t^2 + 2t + 1) \, dt$

$= [t^3 + t^2 + t]_1^3$   
 $= 27 + 9 + 3 - 3 = 36 \text{ J}$

13. Answer (3)

**Hint:**  $\vec{F}_{\text{avg}} = \left( \frac{\Delta \vec{P}}{\Delta t} \right)$

**Sol.:** In vertical direction,  $\vec{P}_i = -mu \cos 60^\circ \hat{j}$

$= -\frac{1}{4} \times 10 \times \frac{1}{2} \hat{j}$

$= \left( \frac{-5}{4} \hat{j} \right) \text{ kg m s}^{-1}$

$\vec{P}_f = me u \cos 60^\circ \hat{j}$

$= \left( \frac{1}{4} \times \frac{1}{2} \times 10 \times \frac{1}{2} \right) \hat{j}$

$= \left( \frac{5}{8} \hat{j} \right) \text{ kg m s}^{-1}$

$|\Delta \vec{P}| = \frac{5}{4} + \frac{5}{8} = \frac{15}{8} \text{ kg m s}^{-1}$

$F_{\text{avg}} = \frac{\Delta P}{\Delta t}$

$= \frac{\frac{15}{8}}{\frac{1}{4}} = \frac{15}{2} \text{ N}$

14. Answer (4)

**Hint & Sol.:** When two bodies of same mass undergo head-on elastic collision, then their velocity, momentum and kinetic energy will be interchanged.

15. Answer (2)

**Hint:**  $v = \frac{dx}{dt}$  and  $K = \frac{1}{2}mv^2$

**Sol.:**  $x = 2t^2 + t^3$

$v = 4t + 3t^2$

$v_f = 4 \times 2 + 3 \times 4 = 20 \text{ m/s}$

$v_i = 4 + 3 = 7 \text{ m/s}$

$\Delta K = \frac{1}{2}m(v_f^2 - v_i^2)$

$= 2(400 - 49) = 702 \text{ J}$

16. Answer (2)

**Hint:** Apply energy conservation principle.

**Sol.:** Only conservative force is acting on the block, therefore total mechanical energy remains conserved.

$(TME)_A = (TME)_B$

$mg(5 \text{ h}) = mg(2 \text{ h}) + \frac{1}{2}mv^2$

$v = \sqrt{6gh}$

At point B :  $N + mg = \frac{mv^2}{R} \Rightarrow N + mg = \frac{m}{h} \times 6gh$

$N = 5mg$

17. Answer (4)

**Hint & Sol.:**  $v = \sqrt{2gx}$

$k = \frac{1}{2}m \times 2gx$

$k \propto x$

18. Answer (3)

**Hint:** Coefficient of restitution

$= \frac{\text{Velocity of separation}}{\text{Velocity of approach}}$

**Sol.:**  $e = \frac{v_1 - u}{3u + u}$

$1 = \frac{v_1 - u}{4u}$

$\Rightarrow v_1 = 5u$

19. Answer (1)

**Hint & Sol:** In compression or expansion, energy

stored is  $U = \frac{1}{2}kx^2$

When work is done against the spring force, this gets stored as potential energy.

20. Answer (3)

**Hint & Sol.:** An object is said to be in stable equilibrium, if on slight displacement from equilibrium position and when released, it comes back to its original position.

21. Answer (1)

**Hint:**  $W_{ext} = \Delta U$

**Sol.:**  $U_i = \frac{1}{2}kx^2$

$U_f = \frac{1}{2}k(y+x)^2$

$W = \frac{1}{2}k(y+x)^2 - \frac{1}{2}kx^2$

$= \frac{1}{2}k(y^2 + x^2 + 2yx - x^2)$

$= \frac{1}{2}ky(y+2x)$

22. Answer (3)

**Hint & Sol.:** Collision is perfectly inelastic so there will be loss of kinetic energy and that loss in kinetic energy will result in increase in temperature. Linear momentum of the system remains conserved.

23. Answer (4)

**Hint & Sol.:** All the given statements are correct with regards to non-conservative force.

24. Answer (4)

**Hint:** Both the balls are identical and collision is elastic, so velocity will get interchanged along line of collision.

**Sol.:**  $v_B = v \cos 30^\circ$

$= 20\sqrt{3} \times \frac{\sqrt{3}}{2} = 30 \text{ m/s}$

$KE = \frac{1}{2}mv^2$

$= \frac{1}{2}(0.1) \times (30)^2 = 45 \text{ J}$

25. Answer (2)

**Hint & Sol.:**  $T_1 = (m_B + m_C) a$

$T_2 = (m_C) a$

$\frac{T_1}{T_2} = \frac{(m+3m)}{3m} = \frac{4}{3}$

26. Answer (2)

**Hint:** A body moving with constant velocity, has constant linear momentum.

**Sol.:**  $\frac{d\vec{P}}{dt} = 0 \Rightarrow \vec{F}_{net} = 0$

$\vec{P} = \text{constant}$

$\vec{v} = \text{constant}$

27. Answer (2)

**Hint:** Sit on the wedge and analyse the FBD of the block.

**Sol.:**  $F_{net} = 0$  in y direction

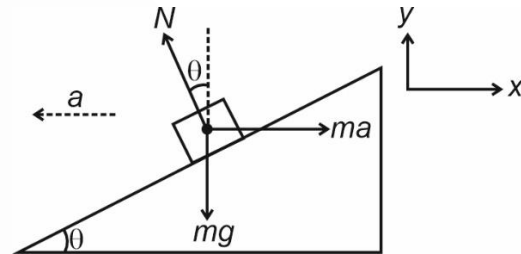

$\therefore N \cos \theta = mg$

28. Answer (1)

**Hint & Sol.:** For 15 kg block :  $F_{net} = ma$

$kx = 15 \times 5$

$kx = 75 \text{ N}$

$100x = 75$

$\Rightarrow x = \frac{3}{4} \text{ m}$

For 30 kg block

$180 - kx = 30 \times a$

$180 - 75 = 30a$

$a = \frac{105}{30} = 3.5 \text{ m/s}^2$

Net force on 30 kg block :

$F = 180 - 75 = 105 \text{ N}$

29. Answer (4)

**Hint:** For maximum acceleration, the tension in the string will be equal to its breaking strength.

**Sol.:**  $T - mg = ma$

$3mg - mg = ma$

$a = 2g$

30. Answer (3)

**Hint:** Books are at rest, therefore net force will be zero on each book

**Sol.:** FBD of B book :

Consider books A and B as a system.

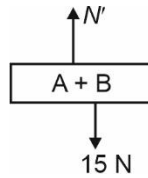

$$F_{\text{net}} = 0$$

$$N - 15 = 0$$

$$N = 15 \text{ N upward}$$

31. Answer (2)

**Hint:**  $F_{\text{net}}$  along the inclined plane is zero.

**Sol.:**  $f - mg\sin\theta = 0$

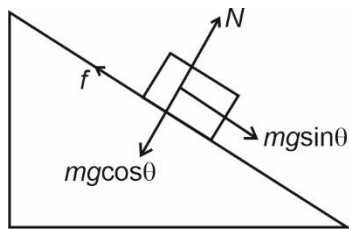

$$\mu_k mg\cos\theta = mgsin\theta$$

$$\mu_k = \tan\theta = \tan 30^\circ = \frac{1}{\sqrt{3}}$$

32. Answer (2)

**Hint:**  $F_{\text{net}} = ma$  and  $T_1 = 2T$

**Sol.:**

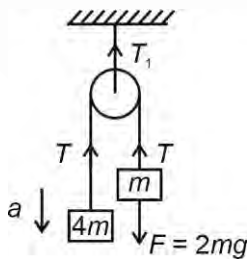

$$4mg - T = 4ma \quad \dots(1)$$

$$T - 3mg = ma \quad \dots(2)$$

on solving equation (1) and (2)

$$\therefore mg = 5ma$$

$$a = \left(\frac{g}{5}\right)$$

on block of mass  $m$ ,

$$T = 3mg + \frac{mg}{5} = \frac{16mg}{5}$$

$$T_1 = 2T = \frac{32mg}{5}$$

33. Answer (1)

**Hint:** Use formula,  $F_{th} = v_r \frac{dm}{dt}$

**Sol.:**  $F_{th} = v_r \frac{dm}{dt}$

$$\Rightarrow 2000 = 180 \times \frac{dm}{dt}$$

$$\Rightarrow \frac{dm}{dt} = \frac{100}{9} \text{ kg/s}$$

34. Answer (1)

**Hint:** Use constraint relation.

**Sol.:**  $a_2 T - 2T a_1 = 0$

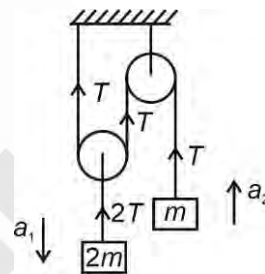

$$a_2 = 2a_1$$

35. Answer (4)

**Hint:** Net force,  $F = \frac{dP}{dt}$

**Sol.:**  $F = \frac{d}{dt}(mvn)$

$$40 = \frac{dn}{dt} \times 100 \times 50 \times 10^{-3}$$

$$\frac{dn}{dt} = 8$$

36. Answer (3)

**Hint:** Angle between tangential acceleration and net acceleration,  $\theta = \tan^{-1}\left(\frac{a_c}{a_t}\right)$ .

**Sol.:**  $\omega = \omega_0 + \alpha t$

$$\omega_t = 2 + 1 \times 2 = 4 \text{ rad/s}$$

$$a_c = \omega^2 r = 16 \times 4 = 64 \text{ m s}^{-2}$$

$$\text{and } a_t = \alpha r = 1 \times 4 = 4 \text{ m s}^{-2}$$

$$\tan\theta = \frac{a_c}{a_t} = \frac{64}{4} = 16$$

$$\theta = \tan^{-1}(16)$$

37. Answer (2)

**Hint:** Since the speed of vehicle is less than optimum speed. Therefore, friction acts in upward direction.

**Sol.:** Banking angle,  $\tan\theta = \frac{v_0^2}{rg} = \frac{400}{100 \times 10} = 0.4$

$\Rightarrow \tan\theta = 0.4 \Rightarrow \theta = 22^\circ$

Now, when  $v = 15 \text{ ms}^{-1}$ , friction is directed upward

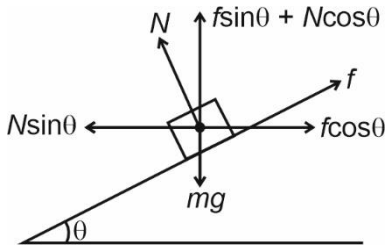

$\Rightarrow$  The vehicle has a tendency to slip in and friction is directed upwards

$\therefore N \sin\theta - f \cos\theta = \frac{mv^2}{R}$

and  $N \cos\theta + f \sin\theta = mg$

eliminating  $N$ , we get

$f[\tan\theta \sin\theta + \cos\theta] = mg \tan\theta - \frac{mv^2}{R}$

$f \left[ \frac{\sin^2\theta + \cos^2\theta}{\cos\theta} \right] = mg \tan\theta - \frac{mv^2}{R}$

$\Rightarrow f = \left( mg \tan\theta - \frac{mv^2}{R} \right) \cos\theta$

$= \left( 500 \times 10 \times 0.4 - \frac{500 \times 225}{100} \right) 0.93$

$= (2000 - 1125) \times 0.93$

$= 813.75 \text{ N}$

38. Answer (3)

**Hint:** Impulse = change in momentum

**Sol.:**  $I = \Delta P = (10t^2 - 4t)$

$10t^2 - 4t = 0$

$t = 0, t = \frac{2}{5} \text{ s}$

39. Answer (3)

**Hint:**  $F_{\text{total}} = M_{\text{net}} \times a$

**Sol.:**  $F_{\text{net}} = 3mg - \mu \times 2mg - \mu mg$

$F_{\text{net}} = 3mg(1 - \mu)$

$a = \frac{F_{\text{net}}}{M} = \frac{3mg(1 - \mu)}{6m} = \frac{g(1 - \mu)}{2}$

40. Answer (3)

**Hint:**  $F = \frac{dP}{dt}$

**Sol.:** From  $t = 0$  to  $t = 6$ ,

$\frac{dP}{dt} = 0$

From  $t = 6$  to  $t = 10$ ,

$\frac{dP}{dt} = -ve \text{ (constant)}$

41. Answer (2)

**Hint:** Only friction force is responsible for motion of block B

**Sol.:** For whole system

$F = m_1 a$

$a = \left( \frac{F}{m_A + m_B} \right)$

$a = \left( \frac{90}{5 + 10} \right) = 6 \text{ m/s}^2$

For block B

$f = m_B \times a$

$= 10 \times 6 = 60 \text{ N}$

42. Answer (4)

**Hint & Sol.:** Friction force also acts when there is tendency of relative motion. Hence statement I is incorrect. Raising the outer edge of a curved road above the inner edge to help vehicles negotiate the curve safely is called banking of the road.

43. Answer (2)

**Hint:** Since  $u < \sqrt{5gl}$ , so it does not complete the circle. It slacks in between.

**Sol.:** Let at point B, string slacks

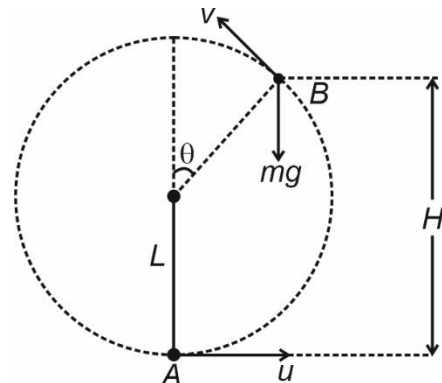

Apply energy conservation between point A and B.

$U_A + k_A = U_B + k_B$

$$\Rightarrow 0 + \frac{1}{2}mu^2 = mgL(1 + \cos\theta) + \frac{1}{2}mv_B^2$$

$$\Rightarrow \frac{u^2}{2} = gL(1 + \cos\theta) + \frac{v_B^2}{2}$$

$$\Rightarrow \frac{4gL}{2} = gL(1 + \cos\theta) + \frac{v_B^2}{2}$$

$$\Rightarrow 2gL = gL(1 + \cos\theta) + \frac{v_B^2}{2}$$

$$\Rightarrow \sqrt{2gL(1 - \cos\theta)} = v_B$$

Now at point B,

$$T + mg\cos\theta = \frac{mv_B^2}{L}$$

$\Rightarrow$  Put  $T = 0$ , because it slacks at that point

$$g\cos\theta = \frac{2gL(1 - \cos\theta)}{L}$$

$$\Rightarrow g\cos\theta = (2 - 2\cos\theta)g$$

$$\Rightarrow 3\cos\theta = 2$$

$$\cos\theta = \frac{2}{3}$$

$$H = L + L\cos\theta$$

$$H = L + \frac{2L}{3}$$

$$H = \frac{5L}{3}$$

44. Answer (3)

$$\text{Hint: } v_m = \sqrt{\mu_s Rg}$$

$$\text{Sol.: } v_m = \sqrt{\frac{1}{2} \times 80 \times 10} = \sqrt{400} = 20 \text{ m/s}$$

45. Answer (4)

**Hint:** Minimum force  $F$  is required when  $f_{\max}$  is equal to  $mg$ .

$$\text{Sol.: } f_{\max} = mg$$

$$\mu F = mg$$

$$\mu = \left(\frac{100}{200}\right) = \frac{1}{2}$$

## [CHEMISTRY]

46. Answer (3)

**Hint:** Atomic weight of middle element is about half way between the atomic weights of other two elements in Dobereiner's Triad if elements are arranged in increasing atomic weights.

**Sol.:** Some example of triad are as

- Li, Na, K
- Ca, Sr, Ba
- Cl, Br, I

47. Answer (1)

**Hint:** Mendeleev predicted existence and position in periodic table for some undiscovered elements.

**Sol.:** Eka Aluminium – Ga

Eka Silicon – Ge

48. Answer (4)

**Hint:** According to Mendeleev's periodic law, the properties of the elements are a periodic function of their atomic weights.

**Sol.:** According to Modern periodic law, the properties of the elements are periodic functions of their atomic numbers.

49. Answer (4)

**Hint:** Ce is first lanthanoid which is introduced in 6<sup>th</sup> period.

**Sol.:** • Group 3 of longest groups with 32 elements.

- Seventh period can have maximum 32 elements.
- Halogens from group 17 are most electronegative.
- 3<sup>rd</sup> and 4<sup>th</sup> period have 8 and 18 elements respectively.

50. Answer (1)

**Hint:** Element with  $Z > 86$  belongs to period 7.

**Sol.:** For element with  $Z = 113$

Period = 7

Group = 13

51. Answer (3)

**Hint:** Y is the first element in which electron is introduced in 4d subshell.

**Sol.:** Cobalt, Rhodium and Iridium belong to 9<sup>th</sup> group in modern periodic table.

52. Answer (3)

**Hint:** Transuranium elements have atomic number greater than 92.

**Sol.:** Atomic number of Np is 93 hence it is a transuranium element.

53. Answer (1)

**Hint:** In order to convert any element to cation electron from outermost shell is removed.

**Sol.:** It is Ge which belongs to 4<sup>th</sup> period and 14<sup>th</sup> group.

54. Answer (3)  
**Hint:** 101 is atomic number of Mendeleevium.  
**Sol.:** 103 is atomic number of Lawrencium.  
 105 is atomic number of Dubnium.  
 107 is atomic number of Bohrium.
55. Answer (3)  
**Hint:** Element from atomic number 87 to 118 will be present in 7<sup>th</sup> period of periodic table.  
**Sol.:** IUPAC naming 1 → un  
 2 → bi  
 4 → quad  
 Name ⇒ Unbiquadium.
56. Answer (4)  
**Hint:** Chlorine is a non-metal.  
**Sol.:** Antimony is a semi-metal  
 Rhenium is a transition metal  
 Promethium is a lanthanoid.
57. Answer (3)  
**Hint:** On moving down the group generally atomic radius increases.  
**Sol.:** On moving left to right in a period, atomic radius generally decreases.  
 $Li > Be > B > C$
58. Answer (3)  
**Hint:** Energy required to remove an electron from an isolated gaseous atom in its ground state is known as ionisation enthalpy.  
**Sol.:** Noble gases have stable electronic configuration so they have large positive electron gain enthalpies.
59. Answer (3)  
**Hint:** As the positive charge increases atomic radius decreases for isoelectronic species.  
**Sol.:** • For any element successive ionisation energy increases.  
 • Formation of multinegative anion  $O^{2-}$ , is always an endothermic process.  
 • During formation of cation, electron is removed from outermost shell.  
 Hence for conversion of Sc to  $Sc^+$ , from Sc, electron will be removed from 4s subshell.
60. Answer (4)  
**Hint:** Group 16 elements are chalcogens.  
**Sol.:** For chalcogens decreasing order of electronegativity is  
 $O > S > Se > Te$

61. Answer (3)  
**Hint:** 3<sup>rd</sup> period element has more negative electron gain enthalpy than 2<sup>nd</sup> period element of same group.  
**Sol.:** For group 16, the correct order of negative electron gain enthalpy is as follows.  
 $S > Se > Te > O$
62. Answer (2)  
**Hint:** On moving left to right in a period, ionisation enthalpy generally increases.  
**Sol.:** • Be has more ionisation enthalpy than B due to more penetrating effect.  
 • N has more ionisation enthalpy than O due to half filled stable configuration.
63. Answer (4)  
**Hint & Sol.:**  $Na^+$ ,  $Mg^{2+}$  and  $Al^{3+}$  all are positive isoelectronic species. So, greater is the charge, smaller will be the size.
64. Answer (3)  
**Hint:** For removal of one electron from stable electronic configuration excessive amount of energy is required hence an abnormal jump in successive ionisation energy will be observed.  
**Sol.:** Number of outermost shell electrons is equal to the number of successive IPs before abnormal jump.

Successive IPs	Number of outer most shell electron(s)	Configuration
x, 2x, 5x, 125x, 130x	3	$1s^2, 2s^2, 2p^6, 3s^2, 3p^1$
y, 30y, 33y, 37y, 43y	1	$1s^2, 2s^2, 2p^6, 3s^1$
z, 5z, 90z, 94z, 99z	2	$1s^2, 2s^2, 2p^6, 3s^2$
p, 4p, 9p, 17p, 102p	4	$1s^2, 2s^2, 2p^6, 3s^2, 3p^2$

65. Answer (1)  
**Hint:** Valence of group 1 element is 1.  
**Sol.:** Valence of group 2 element is 2.  
 Valence of group 15 element is 3, 5.  
 Valence of group 14 element is 4.
66. Answer (2)  
**Hint:** Group 1 elements form basic oxide.  
**Sol.:**  $Al_2O_3$  is amphoteric  $Na_2O$  is basic,  $SiO_2$  is acidic and  $N_2O$  is neutral oxide.

67. Answer (3)

**Hint:** B has 6 electrons in outermost shell in  $\text{BH}_3$  molecule.

**Sol.:** In  $\text{H}_2\text{SO}_4$ , there are 12 electrons around the S atom hence it is termed as expanded octet.

68. Answer (1)

**Hint:** Electrovalence is equal to unit charge on the ion.

**Sol.:**

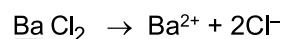
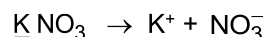
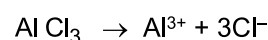
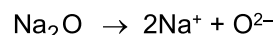

69. Answer (1)

**Hint:** Formal charge (F.C.) on an atom in a Lewis structure = [total number of valence electrons in the free atom] – [total number of non-bonding (lone pair) electrons] – (1/2) [total number of bonding (shared) electrons].

$$\text{Sol.} \text{ For O} - 1 \Rightarrow \text{FC} = 6 - 4 - \frac{1}{2}(4) = 0$$

$$\text{For O} - 2 \Rightarrow \text{FC} = 6 - 2 - \frac{1}{2}(6) = +1$$

$$\text{For O} - 3 \Rightarrow \text{FC} = 6 - 6 - \frac{1}{2}(2) = -1$$

70. Answer (1)

**Hint:** Lattice energy increases with magnitude of the charge and decrease with size of ions.

**Sol.:** For common anion, as charge of cation increase, lattice energy also increase.

Order :  $\text{Na}_2\text{O} < \text{MgO} < \text{Al}_2\text{O}_3$

71. Answer (2)

**Hint:** Generally as size of atom decreases, bond length also decreases.

**Sol.:**

Bond type	Bond length
C – H	107 pm
N – O	136 pm
C – O	143 pm

72. Answer (4)

**Hint & Sol.:**

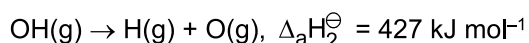
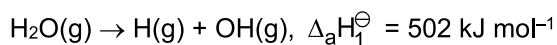

73. Answer (3)

**Hint:** Isoelectronic molecules and ions have identical bond order; for example,  $\text{F}_2$  and  $\text{O}_2^{2-}$  have bond order 1.  $\text{N}_2$ ,  $\text{CO}$  and  $\text{NO}^+$  have bond order 3.

**Sol.:**

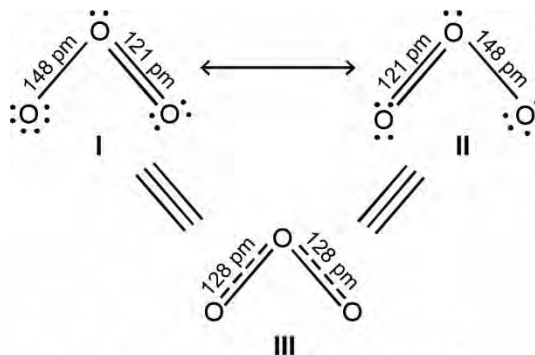

Resonance in the  $\text{O}_3$  molecule

• BE of  $\text{H}_2$  is  $435.8 \text{ kJ mol}^{-1}$  while BE of  $\text{HCl}$  is  $431 \text{ kJ mol}^{-1}$ .

74. Answer (1)

**Hint:** The molecule that shows resonance cannot be depicted by a single Lewis structure.

**Sol.:** The canonical forms have no real existence.

75. Answer (2)

**Hint:**  $\text{H}_2\text{O}$  has very high dipole moment.

**Sol.:**

Molecule	Dipole moment
$\text{H}_2\text{O}$	1.85 D
$\text{HCl}$	1.07 D
$\text{NH}_3$	1.47 D

76. Answer (1)

**Hint & Sol.:** The repulsive interaction of electron pairs decrease in the order:

Lone pair (lp) – Lone pair (lp) > Lone pair (lp) – Bond pair (bp) > Bond pair (bp) – Bond pair (bp)

77. Answer (4)

**Hint:** Shape of  $\text{SO}_2$  is bent.

**Sol.:** Shape of  $\text{ClF}_3$  is T-shape

Shape of  $\text{SF}_4$  is see-saw

Shape of  $\text{XeF}_4$  is square planar

78. Answer (3)

**Hint:**  $\text{PCl}_5$  is trigonal bipyramidal molecule with  $sp^3d$  hybridisation.

**Sol.:** Axial bonds are longer than equatorial bonds.

$$\mu_{\text{net}} = 0$$

79. Answer (2)

**Hint:** When orbitals of two atoms come close to form bond, their overlap may be positive, negative or zero depending upon the sign (phase) and direction of orientation of amplitude of orbital wave function in space.

**Sol.:**

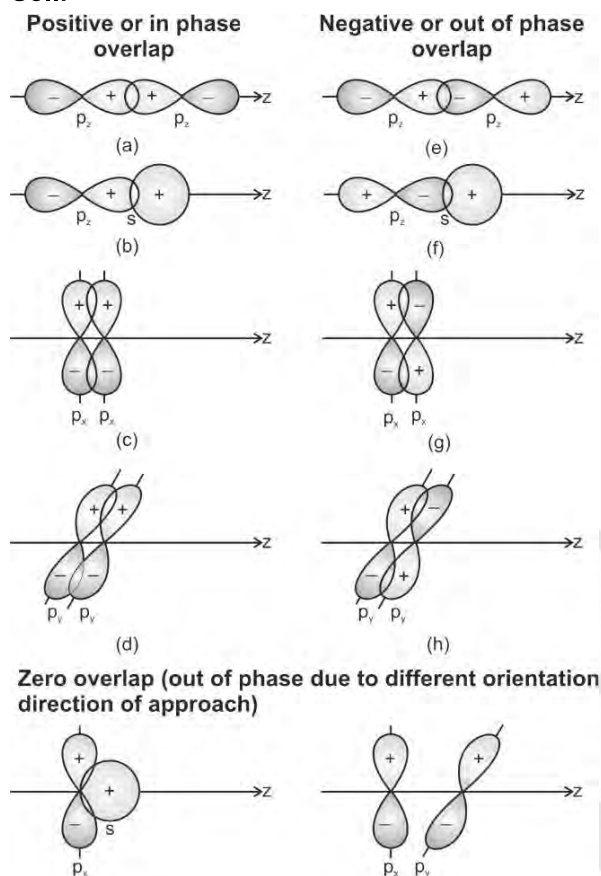

80. Answer (2)

**Hint & Sol.:** The hybrid orbitals are always equivalent in energy and shape.

81. Answer (4)

**Hint:** Nitrogen in  $\text{NH}_3$  is  $sp^3$  hybridised.

**Sol.:**  $\text{ClO}_4^- - sp^3$

$\text{PCl}_3 \rightarrow sp^3$

$[\text{Co}(\text{NH}_3)_6]^{3+} - d^2sp^3$

82. Answer (4)

**Hint & Sol.:** Orbital involved in  $dsp^2$  hybridisation are  $\underbrace{d_{x^2-y^2}}_{\text{inner}} + s + p_x + p_y$ .

83. Answer (1)

**Hint & Sol.:** The combining atomic orbitals must have the same or nearly the same energy. This means that 1s orbital can combine with another 1s orbital but not with 2s orbital because the energy of 2s orbital is appreciably higher than that of 1s orbital.

84. Answer (3)

**Hint:**

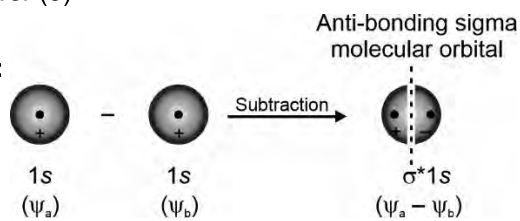

**Sol.:**

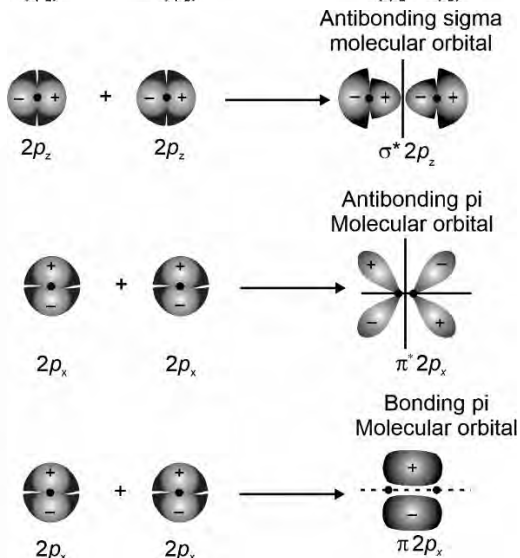

85. Answer (2)

**Hint:** % Ionic character =  $\frac{\mu_{\text{observed}}}{\mu_{\text{calculated}}} \times 100$

**Sol.:**  $\mu_{\text{calculated}} = q \times d$ , [Here  $q = 4.8 \times 10^{-10}$  esu]  
 $= 4.8 \times 10^{-10}$  esu  $\times 99 \times 10^{-10}$  cm  
 $= 4.75 \times 10^{-18}$  esu - cm

$\mu_{\text{observed}} = 1.88$  D

$= 1.88 \times 10^{-18}$  esu - cm

% Ionic character =  $\frac{1.88 \times 10^{-18}}{4.75 \times 10^{-18}} \times 100$

$= 39.57\%$

86. Answer (2)

**Hint:**  $\text{O}_2$  has two unpaired electrons in  $\pi$  antibonding molecular orbital.

**Sol.:** • Magnetic moment  $\mu = \sqrt{n(n+2)}$  BM

$= \sqrt{2(2+2)}$  BM

$= 2.92$  BM

• During conversion of  $\text{N}_2$  to  $\text{N}_2^+$  electron is removed from  $\sigma 2p_z$  orbital.

87. Answer (2)

**Hint:**  $\text{B}_2$  molecule has single  $\pi$  bond.

**Sol.:**  $\text{N}_2 \rightarrow 1\sigma$  and  $2\pi$  bonds

$\text{O}_2 \rightarrow 1\sigma$  and  $1\pi$  bonds

$\text{Li} \rightarrow 1\sigma$  bond

$\text{C}_2 \rightarrow 2\pi$  bonds.

88. Answer (3)

**Hint:** Dipole moment of a molecule is vector sum of all the bond moments.

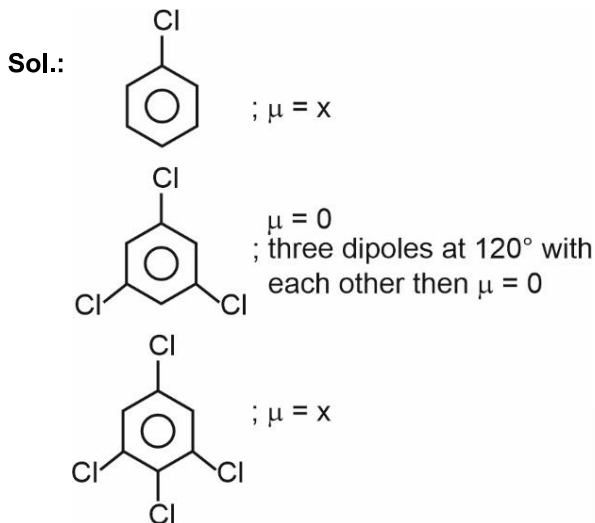

89. Answer (4)

**Hint:** If H-bond is formed within the molecule it is considered as intramolecular hydrogen bond.

**Sol.:**

<chem>Oc1ccc(C=O)cc1</chem>	→	Intermolecular H-bond
<chem>Oc1ccc([N+](=O)[O-])cc1</chem>	→	Intermolecular H-bond
<chem>Cc1cc(O)ccc1</chem>	→	Intermolecular H-bond
<chem>Oc1ccccc1[N+](=O)[O-]</chem>	→	Intramolecular H-bond

90. Answer (2)

**Hint & Sol.:** *p*-block of modern periodic table contains metal, nonmetal and metalloids.

## [BOTANY]

91. Answer (3)

**Hint:** Axillary bud has meristematic cells.

**Sol.:** Sepals, petiole and stipule have chlorophyll. Axillary buds lack chlorophyll.

92. Answer (1)

**Hint:** In vexillary aestivation, one large posterior petal is known as standard.

**Sol.:** In members of Fabaceae, two lateral petals form wings, two anterior ones form a keel that encloses stamen and pistil and one large posterior standard petal are found.

93. Answer (3)

**Hint:** The outer covering of endosperm separates the embryo by a proteinaceous layer called aleurone layer.

**Sol.:** Aleurone layer is proteinaceous, and it surrounds the nutritive tissue. It is found in the monocotyledonous seeds.

94. Answer (2)

**Hint:** Bud may develop into a branch, flower or tendril.

**Sol.:** Bud are not found in axil of leaflets rather found in axil of compound leaf. Internodes of stem and underground stem lack buds.

95. Answer (4)

**Hint:** Pericarp is the fruit wall which is thick and fleshy and further differentiated into three layers.

**Sol.:** When pericarp is thick and fleshy, it is differentiated into outer epicarp, the middle mesocarp and the inner endocarp.

96. Answer (4)

**Hint:** In some leguminous plants, the leaf base swells and is called pulvinus.

**Sol.:** In a monocotyledonous plant, the primary root is short lived and is generally replaced by a number of fine fibrous roots. These roots originate from the base of the stem and constitute the fibrous root system. The seeds obtained are endospermous.

97. Answer (3)

**Hint:** When shoot apical meristem changes to floral meristem, the apex produces different kind of floral appendages laterally at successive nodes instead of leaves.

**Sol.:** A typical flower has four different kinds of whorls which are arranged successively on the swollen end of the stalk or pedicel called thalamus.

98. Answer (3)  
**Hint:** Silk cotton shows the presence of palmately compound leaves.  
**Sol.:** In palmately compound leaves, leaflets are attached to a common point, i.e., tip of a petiole.
99. Answer (4)  
**Hint:** Axillary buds develop at the axil of leaf.  
**Sol.:** Axillary buds do not form leaf. Bracts are found at the base of pedicel.
100. Answer (1)  
**Hint:** It is the region proximal to the region of meristematic activity towards root cap.  
**Sol.:** The cells found in the region of elongation undergo rapid elongation and enlargement and are responsible for the growth of the root in length.
101. Answer (2)  
**Hint:** In the given structure of the monocot seed, label A is aleurone layer, label B is endosperm, label C is scutellum, label D is plumule and label E is coleorhiza.  
**Sol.:** Endosperm is the result of double fertilization. Aleurone layer is proteinaceous in nature. Monocot seed consists of a large and shield shaped cotyledon known as scutellum. The plumule and radicle are enclosed in the sheaths called coleoptile and coleorhiza respectively.
102. Answer (3)  
**Hint:** Solanaceae family is commonly known as potato family and it produces endospermous seeds.  
**Sol.:** In members of solanaceae, actinomorphic flower, valvate aestivation, epipetalous androecium and axile placentation is present.
103. Answer (3)  
**Hint:** Lily and bean belong to liliaceae and fabaceae family respectively.  
**Sol.:** In lily, sepals and petals are not distinguished and perianth is found.
104. Answer (4)  
**Hint:** Leaf blade is also known as lamina.  
**Sol.:** In some leguminous plants, the leaf base may become swollen, which is called the pulvinus. The petiole helps hold the blade to light. Long thin flexible petioles allow leaf blades to flutter in wind. The lamina or the leaf blade is the green expanded part of the leaf with veins and veinlets.
105. Answer (2)  
**Hint:** In China rose, monoadelphous condition of stamens is present.  
**Sol.:** In China rose, cohesion of stamens is observed. In floral diagram, four floral whorls can be easily distinguished.
106. Answer (3)  
**Sol.:** In the members of Fabaceae eg. Pea marginal placentation is seen.
107. Answer (2)  
**Hint:** In cymose inflorescence, basipetal arrangement of flowers is present.  
**Sol.:** In cymose inflorescence, the main axis terminates into flower and hence, has a limited growth. In cymose inflorescence, the flowers are borne in the basipetal order.
108. Answer (4)  
**Hint:** Lemon and members of Solanaceae show axile placentation.  
**Sol.:** *Argemone* and mustard show parietal placentation. *Primrose* and *Dianthus* show free central placentation.
109. Answer (2)  
**Hint:** When stamens are united into two bundles, then it is called diadelphous condition.  
**Sol.:** Diadelphous condition can be represented as  $A_{(n)+(n)}$ .
110. Answer (1)  
**Hint:** Single ovule, attached to placenta is found in the plants having basal placentation.  
**Sol.:** In sunflower, placenta develops at the base of the ovary and it has single ovule attached to the placenta.
111. Answer (2)  
**Hint:** According to R.H Whittaker's, five kingdom classification system, kingdom Animalia includes organisms with tissue/ organ/organ system level of body organization with heterotrophic mode of nutrition only.  
**Sol.:** Kingdom Protista has brought together *Chlamydomonas* and *Chlorella* with *Paramecium* and *Amoeba*.
112. Answer (2)  
**Hint:** Cyanobacteria have some specialized cells called heterocyst in which atmospheric nitrogen can be fixed.  
**Sol.:** Some cyanobacteria can fix atmospheric nitrogen in specialised cells called heterocyst, while other cells fix  $\text{CO}_2$ .

113. Answer (2)

**Hint:** All single celled eukaryotes are put under the kingdom Protista. Euglenoids, slime moulds and members of Protozoa do not have cell wall.

**Sol.:** Euglenoids have pigments identical to higher plants and perform oxygenic photosynthesis, slime moulds are saprophytic in nature.

114. Answer (4)

**Hint:** The sexual life cycle of fungi involves the following steps

Plasmogamy → Karyogamy → Meiosis

**Sol.:** These steps occur as:

- (i) Fusion of protoplasts between two motile or non-motile gametes called plasmogamy.
- (ii) Fusion of two nuclei called karyogamy.
- (iii) Meiosis in zygote resulting in haploid spores.

115. Answer (2)

**Hint:** Asexual spores are absent in club fungi.

**Sol.:** All the given characteristics are true for the members of class Basidiomycetes.

116. Answer (2)

**Hint:** A zygospore is formed by the fusion of two gametes in the members of zygomycetes.

**Sol.:** *Neurospora* belongs to the class ascomycetes. Zygospores are formed in the members of zygomycetes.

117. Answer (3)

**Hint:** Two kingdom system of classification was given by Linnaeus. The proposed two kingdoms are Animalia and Plantae.

**Sol.:** The classification system given by Linnaeus did not distinguish between the eukaryotes and prokaryotes, unicellular and multicellular organisms and photosynthetic (green algae) and non-photosynthetic (fungi) organisms.

118. Answer (4)

**Hint:** *Agaricus* belongs to the class basidiomycetes in which vegetative reproduction commonly takes place by fragmentation.

**Sol.:** *Albugo* is a member of phycmycetes in which mycelium is aseptate and coenocytic. *Colletotrichum* belongs to the class deuteromycetes and they are commonly known as imperfect fungi.

*Neurospora* belongs to the class ascomycetes, in which ascospores (sexual spores) are produced endogenously.

119. Answer (1)

**Hint:** T.O. Diener discovered viroids, which are infectious RNA particles and they are devoid of the protein coat.

**Sol.:** Dmitri Ivanowsky (1892) recognised certain microbes as causal organism of the mosaic disease of tobacco. M.W. Beijerinck (1898) demonstrated that the extract of the infected plants of tobacco could cause infection in healthy plants and called the fluid as "*Contagium vivum fluidum*" (infectious living fluid).

W.M. Stanley (1935) showed that viruses could be crystallised and crystals consist largely of proteins.

120. Answer (1)

**Hint:** Slime moulds are saprophytic protists, and during unfavourable condition, the plasmodium differentiates and forms the fruiting bodies bearing spores at their tips.

**Sol.:** In slime moulds, the spores possess true walls. They are extremely resistant and survive for many years even under the adverse condition.

121. Answer (2)

**Hint:** The kingdom, whose sole members are bacteria is divided into two different domains in six kingdom classification.

**Sol.:** In three domain system, kingdom Monera is divided into two different domains.

122. Answer (4)

**Sol.:** Lupin is the ornamental plant of family Fabaceae.

123. Answer (4)

**Hint:** Lotus has apocarpous gynoecium.

**Sol.:** Lotus is multicarpellary, while pea is monocarpellary.

124. Answer (1)

**Hint:** Prions are abnormally folded proteins which cause mad cow disease in cattle

**Sol.:** Viroid lacks protein coat and causes potato spindle tuber disease. It consists of RNA of low molecular weight.

125. Answer (1)

**Hint:** Morels and truffles belong to the same class of fungi, i.e., ascomycetes

**Sol.:** Mushroom belongs to basidiomycetes and morels belong to the ascomycetes and they both are edible.

126. Answer (3)

**Hint:** In the members of both ascomycetes and basidiomycetes an intervening dikaryophase occurs.

**Sol.:** Basidiomycetes lack asexual reproduction. In both ascomycetes and basidiomycetes, meiosis takes place for formation of spores.

127. Answer (3)

**Hint:** In lichens, the algal component is known as phycobiont and fungal component as mycobiont, which are autotrophic and heterotrophic respectively.

**Sol.:** In lichens, a mutualistic relationship is observed. The algal component prepares food for fungi and fungi provide shelter and absorb mineral nutrients for its partner.

128. Answer (4)

**Hint:** Bacteria are simple in structure and complex in behaviour.

**Sol.:** According to R.H. Whittaker's five kingdom classification, organisms with simple body organization but very complex behaviour are placed under the kingdom Monera.

129. Answer (1)

**Hint:** They are also involved in the methane production.

**Sol.:** Methanogens are present in the gut of several ruminants such as cows and buffaloes and they are responsible for the production of methane (biogas).

130. Answer (3)

**Hint:** Mycoplasma is pathogenic in nature.

**Sol.:** Mycoplasma can affect both plants and animals.

131. Answer (3)

**Hint:** This organism belongs to dinoflagellates.

**Sol.:** Red dinoflagellates, *Gonyaulax* undergo rapid multiplication, due to which they make the sea appear red.

132. Answer (2)

**Hint:** Sleeping sickness is caused by *Trypanosoma*.

**Sol.:** *Trypanosoma* is a flagellated protozoan. The members of this group are either free living or parasitic.

133. Answer (1)

**Hint:** Viruses that infect plant have RNA

**Sol.:** In general, the viruses that infect plants have ssRNA as genetic material.

134. Answer (1)

**Hint:** In members of phycomycetes, asexual reproduction takes place by zoospores or aplanospores.

**Sol.:** According to R.H. Whittaker's classification, kingdom plantae includes autotrophic organisms. Bladderwort and Venus fly trap are examples of insectivorous plants i.e., partial heterotroph and *Cuscuta* is a parasite, still they are placed in kingdom plantae.

135. Answer (3)

**Hint:** Sporozoans do not have any locomotory structure.

**Sol.:** *Plasmodium* is a sporozoan and it lacks flagella or any locomotory structure.

## [ZOOLOGY]

136. Answer (3)

**Hint:** Include different levels of body organisation

**Sol.:** Mechanisms of breathing vary among different groups of animals depending mainly on their habitats and levels of organisation.

Lower invertebrates like sponges, coelenterates, flatworms, etc., exchange O<sub>2</sub> with CO<sub>2</sub> by simple diffusion over their entire body surface. Earthworms use moist cuticle. Likewise, complex organisms use specialised organs for respiration.

137. Answer (1)

**Hint:** Arthropods and molluscs have open circulatory system.

**Sol.:** Open circulatory system is present in arthropods and molluscs in which blood pumped by the heart passes through large vessels into open spaces or body cavities called sinuses. Annelids and chordates have a closed circulatory system in which the blood pumped by the heart is always circulated through a closed network of blood vessels.

Butterfly – Arthropod

Humans, crocodiles – Chordates

Sponges – Poriferans (circulatory system absent)

138. Answer (3)

**Hint:** Pulmonary ventilation is the first step in respiration.

**Sol.:** First step in respiration is breathing or pulmonary ventilation by which atmospheric air is drawn in and CO<sub>2</sub> rich alveolar air is released out.

Nearly, 70 per cent of carbon dioxide is transported as bicarbonate (HCO<sub>3</sub><sup>-</sup>) through the blood plasma.

139. Answer (2)

**Hint:** Diffusion membrane is made up of 3 major layers.

**Sol.:** The diffusion membrane is made up of 3 major layers namely, the thin squamous epithelium of alveoli, the endothelium of alveolar capillaries and the basement substance in between them. However, its total thickness is much less than a millimetre.

140. Answer (1)

**Hint:** Role of oxygen in regulation of respiratory rhythm is insignificant.

**Sol.:** Receptors associated with aortic arch and carotid artery can recognise changes in CO<sub>2</sub> and H<sup>+</sup> concentration and send necessary signals to the rhythm centre for remedial actions. The role of oxygen in the regulation of respiratory rhythm is quite insignificant.

141. Answer (4)

**Hint:** Haemoglobin contains 2 $\alpha$  and 2 $\beta$  chains.

**Sol.:** Haemoglobin is a red coloured iron containing pigment present in the RBCs. Each haemoglobin molecule can carry a maximum of four molecules of O<sub>2</sub>. Haemoglobin is a respiratory pigment in both vertebrates and invertebrates.

Each haemoglobin has one iron atom in each  $\alpha$  and  $\beta$  chain.

142. Answer (1)

**Hint:** RBCs are absent in lymph.

**Sol.:** Exchange of nutrients, gases, etc., between the blood and the cells always occur through tissue fluid (lymph). An elaborate network of vessels called the lymphatic system collects this fluid and drains it back to the major veins. Lymph is a colourless fluid containing specialised lymphocytes which are responsible for the immune responses of the body. Interstitial fluid enables intercellular communication between the cells.

143. Answer (1)

**Hint:** Capillaries facilitate diffusion.

**Sol.:** Each artery and vein consist of three layers: an inner lining of squamous endothelium, the tunica intima, a middle layer of smooth muscle and elastic fibres, the tunica media, and an external layer of fibrous connective tissue with collagen fibres, the tunica externa.

The walls of capillaries are composed of just one cell thick layer – a squamous epithelium or endothelium. So, it forms diffusion boundaries.

144. Answer (1)

**Hint:** Volume that cannot be measured by spirometer

**Sol.:** **Vital Capacity (VC):** The maximum volume of air a person can breathe in after a forced expiration. or the maximum volume of air a person can breathe out after a forced inspiration. This includes ERV, TV and IRV.

**Residual Volume (RV):** Volume of air remaining in the lungs even after a forcible expiration. This averages 1100 mL to 1200 mL.

145. Answer (3)

**Hint:** pCO<sub>2</sub> in deoxygenated blood = 45 mm Hg.

**Sol.:**

Respiratory Gas	Atmospheric Air	Alveoli	Blood (Deoxygenated)	Blood (Oxygenated)	Tissues
O <sub>2</sub>	159	104	40	95	40
CO <sub>2</sub>	0.3	40	45	40	45

146. Answer (4)

**Hint:** Arteries carry blood away from heart.

**Sol.:** The deoxygenated blood pumped into the pulmonary artery is passed on to the lungs from where the oxygenated blood is carried by the pulmonary veins into the left atrium. This pathway constitutes the pulmonary circulation. The oxygenated blood entering the aorta is carried by a network of arteries, arterioles and capillaries to the tissues from where the deoxygenated blood is collected by a system of venules, veins and vena cava and emptied into the right atrium. This is the systemic circulation.

147. Answer (1)

**Hint:** The process of exhalation

**Sol.:** Relaxation of the diaphragm and the intercostal muscles returns the diaphragm and sternum to their normal positions and reduce the thoracic volume and thereby the pulmonary volume. This leads to an increase in intra-pulmonary pressure to slightly above the atmospheric pressure causing the expulsion of air from the lungs, i.e., expiration.

148. Answer (3)

**Hint:** 70% filling of ventricles during relaxation.

**Sol.:** Blood from pulmonary veins and vena cava, fill left and right atria respectively. The buildup of pressure that results due to filling of atria, just before joint diastole and decreased pressure in ventricles during diastole, causes the AV valves to open during joint diastole and blood to flow from atria to ventricles. Nearly 70% of ventricles get filled with blood during joint diastole.

149. Answer (4)

**Hint:** Utilisation of O<sub>2</sub> by cells for metabolism is last step.

**Sol.:** Respiration involves the following steps.

- Pulmonary ventilation
- Diffusion of gases across alveolar membrane.
- Transport of gases by blood
- Diffusion of O<sub>2</sub> and CO<sub>2</sub> between blood and tissues
- Cellular respiration

150. Answer (2)

**Hint:** Volume of air inspired / expired per minute.

**Sol.:** Tidal volume is the volume of air inspired or expired during a normal respiration. It is approx. 500 mL *i.e.*, a healthy man can inspire or expire approximately 6000 to 8000 mL of air per minute (minute respiratory volume) under normal conditions.

151. Answer (1)

**Hint:** Serum = Plasma – Clotting factors.

**Sol.:** Clotting factors are responsible for blood coagulation.

Lymph, plasma and blood, all contain clotting factors and they will coagulate when left undisturbed under normal conditions. Serum on the other hand, is devoid of clotting factors, so it will not coagulate.

152. Answer (4)

**Hint:** Tricuspid valve is present between the right atrium and right ventricle.

**Sol.:** Tricuspid valve is present between right atrium and ventricle. Any damage to chordae tendineae of tricuspid valve will affect the blood flow into right atrium and further to right ventricle. Bicuspid valve is present between left atrium and left ventricle.

153. Answer (4)

**Hint:** High pH can shift the oxygen dissociation curve towards left

**Sol.:** Low pO<sub>2</sub>, high pCO<sub>2</sub>, high H<sup>+</sup> concentration and high temperature are the factors responsible for dissociation of oxygen from oxyhaemoglobin. These factors cause the reduced affinity of Hb to O<sub>2</sub> and lead to right shift of sigmoidal oxygen dissociation curve.

154. Answer (3)

**Hint:** ANS constitutes sympathetic and parasympathetic nervous system.

**Sol.:** ANS constitutes sympathetic and parasympathetic nervous system. Neural signals through sympathetic nerve fibres (part of ANS) can increase the rate of heart beat, the strength of ventricular contraction and thereby the cardiac output. On the other hand, parasympathetic neural signals (another component of ANS) decrease the rate of heart beat, speed of conduction of action potentials and thereby the cardiac output.

155. Answer (3)

**Hint:** Hypertensive individual has blood pressure 140/90 mmHg or above.

**Sol.:** Hypertension is the term for blood pressure that is higher than normal (120/80). In this measurement, 120 mm Hg is the systolic or pumping pressure and 80 mm Hg is the diastolic, or resting pressure. If repeated checks of blood pressure of an individual are 140/90 or higher, it shows hypertension. High blood pressure leads to heart diseases and also affects vital organs like brain and kidney. Blood pressure is measured by sphygmomanometer.

156. Answer (3)

**Hint:** Number of ear ossicles in an ear of man.

**Sol.:** Dark reddish-brown scum is formed at the site of a cut or an injury over a period of time. It is a clot or coagulum formed mainly of a network of threads called fibrins in which dead and damaged formed elements are trapped.

Fibrins are formed by the conversion of inactive fibrinogens present in plasma by the enzyme called thrombin.

An injury or a trauma stimulates the platelets in the blood to release certain factors which activate the mechanism of coagulation.

157. Answer (2)

**Hint:** Superior vena cava opens into right atrium.

**Sol.:** • Tricuspid valve opens into right ventricle.

- Bicuspid valve opens into left ventricle.
- Inferior vena cava and superior vena cava open into right atrium.
- Pulmonary veins open into left atrium.

158. Answer (4)

**Hint:** A part of hindbrain

**Sol.:** A specialised centre present in the medulla region of the brain called respiratory rhythm centre is primarily responsible for this regulation.

Normal activities of the heart are regulated intrinsically, *i.e.*, auto regulated by specialised muscles (nodal tissue), hence the heart is called myogenic. A special neural centre in the medulla oblongata can moderate the cardiac function through autonomic nervous system (ANS).

159. Answer (4)

**Hint:** Pisces exhibit single circulation.

**Sol.:** Fishes exhibit single circulation. Mammals and birds exhibit complete double circulation. Reptiles and amphibians exhibit incomplete double circulation.

160. Answer (3)

**Hint:** Cardiac output = Heart rate × stroke volume

**Sol.:** Cardiac output = 4000 mL

Stroke volume = End diastolic volume - End systolic volume = 90-40 mL = 50 mL

Cardiac output = Heart rate × stroke volume

4000 mL = heart rate × 50 mL

Heart rate = 4000 mL/50 mL

Heart rate = 80 beats per minute

161. Answer (4)

**Hint:** An Rh -ve person if exposed to Rh +ve blood, will form specific antibodies.

**Sol.:**

Blood Group	Antigens on RBCs	Antibodies in Plasma	Donor's Group
A	A	anti-B	A, O
B	B	anti-A	B, O
AB	A, B	nil	AB, A, B, O
O	nil	anti-A, B	O

Another antigen, the Rh antigen similar to one present in Rhesus monkeys, is also observed on the surface of RBCs of majority of humans.

Such individuals are called Rh positive and those in whom this antigen is absent are called Rh negative. An Rh -ve person, if exposed to Rh +ve blood, will form specific antibodies against the Rh antigens. Therefore, Rh group should also be matched before blood transfusions.

162. Answer (2)

**Hint:** p50 value < 50 mm Hg

**Sol.:** p50 value refers to the partial pressure of oxygen at which haemoglobin is 50% saturated with oxygen. A normal p50 value in humans is typically 25 – 30 mm Hg.

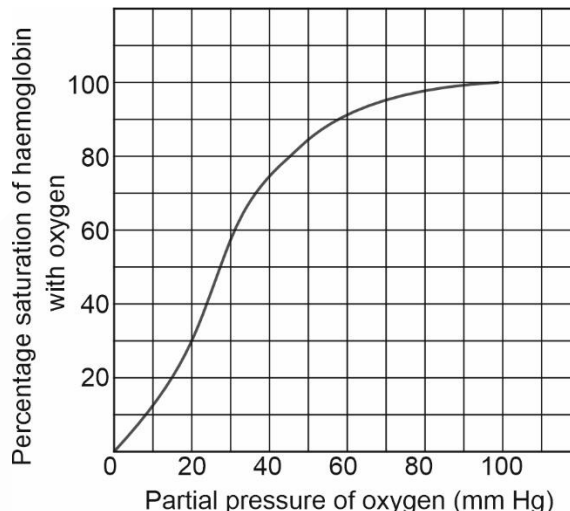

163. Answer (2)

**Hint:** At tissue site, pCO<sub>2</sub> is high

**Sol.:** At tissue site, where partial pressure of CO<sub>2</sub> is high due to catabolism, CO<sub>2</sub> diffuses into blood (RBCs and plasma) and forms HCO<sub>3</sub><sup>-</sup> and H<sup>+</sup>.

At the alveolar site where pCO<sub>2</sub> is low and pO<sub>2</sub> is high, the reaction proceeds in the opposite direction leading to the formation of CO<sub>2</sub> and H<sub>2</sub>O. Thus, CO<sub>2</sub> trapped as bicarbonate at the tissue level is transported to the alveoli and then released out as CO<sub>2</sub>.

164. Answer (3)

**Hint:** Backbone represents dorsal axis.

**Sol.:** The human lungs are situated in the thoracic chamber, which is anatomically an air-tight chamber. The thoracic chamber is formed dorsally by the vertebral column, ventrally by the sternum, laterally by the ribs and on the lower side by the dome shaped diaphragm.

165. Answer (1)

**Hint:** Valves prevent backward blood flow.

**Sol.:** The opening of the right and left ventricles into the pulmonary artery and the aorta respectively are guarded with semilunar valves. The valves in heart allow the flow of blood only in one direction *i.e.* from atria to the ventricles and from the ventricles to the pulmonary artery and aorta.

166. Answer (2)

**Hint:** Asthma is a difficulty in breathing causing wheezing.

**Sol.:**

Heart failure	Heart is not pumping blood effectively enough to meet needs of body
Asthma	Difficulty in breathing due to inflammation of bronchi and bronchioles
Cardiac arrest	Heart stops beating
Emphysema	Alveolar walls are damaged due to which respiratory surface is decreased

167. Answer (3)

**Hint:** Lymphocytes are agranulocytes.

**Sol.:** Neutrophils are the most abundant cells (60-65 per cent) of the total WBCs and basophils are the least (0.5-1 per cent) among them. Basophils secrete histamine, serotonin, heparin, etc., and are involved in inflammatory reactions. Neutrophils, eosinophils and basophils are different types of granulocytes, while lymphocytes and monocytes are the agranulocytes.

168. Answer (4)

**Hint:** Basophils are the least abundant formed element

**Sol.:** Percentage of lymphocytes in total WBCs = 20-25%

Per centage of eosinophils in total WBCs = 2-3%

Per centage of monocytes in total WBCs = 6-8%

Per centage of basophils in total WBCs = 0.5-1%

Per cent of  $\text{CO}_2$  transported as carbaminohemoglobin = 20-25%

Per cent of  $\text{O}_2$  transported in dissolved state = 3%

Per cent of  $\text{CO}_2$  transported in dissolved state = 7%

Per cent of  $\text{O}_2$  transported as oxyhaemoglobin = 97%

169. Answer (4)

**Hint:** Vascularised bag-like structures.

**Sol.:** Larynx is a cartilaginous box which helps in sound production. During swallowing, glottis can be covered by thin elastic cartilaginous flap called epiglottis.

Trachea, primary, secondary and tertiary bronchi and initial bronchioles are supported by cartilaginous rings.

170. Answer (1)

**Hint:** White blood cells.

**Sol.:** Leucocytes are also known as white blood cells (WBC) as they are colourless due to the lack of haemoglobin. They are nucleated and are relatively lesser in number which averages  $6000\text{--}8000\text{ mm}^{-3}$  of blood. Leucocytes are generally short lived. A healthy adult man has on average 5 million to 5.5 million of RBC  $\text{mm}^{-3}$  of blood. Blood normally contains  $1,50,000\text{--}3,50,000$  platelets  $\text{mm}^{-3}$ .

171. Answer (1)

**Hint:** Systemic arteries carry oxygenated blood.

**Sol.:**

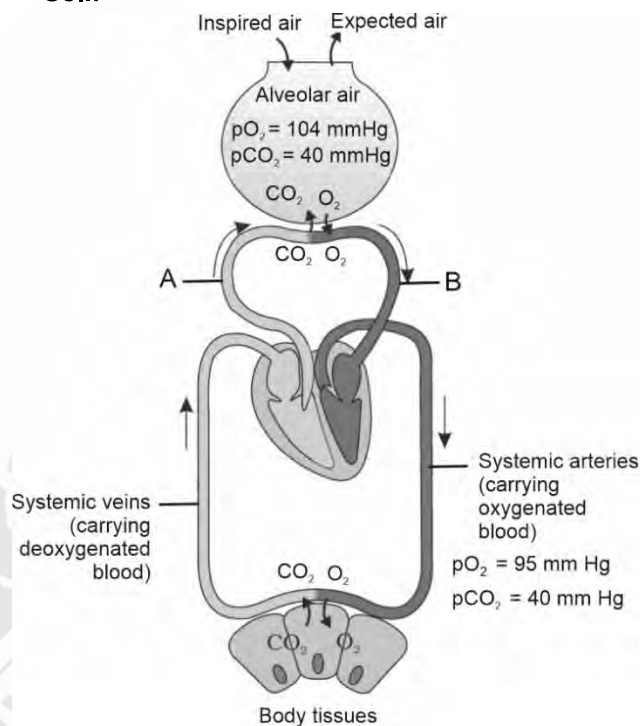

172. Answer (1)

**Hint:** Closure of tricuspid and bicuspid valves produces first heart sound.

**Sol.:** During each cardiac cycle, two prominent sounds are produced which can be easily heard through a stethoscope. The first heart sound (lub) is associated with the closure of the tricuspid and bicuspid valves whereas the second heart sound (dub) is associated with the closure of the semilunar valves. These sounds are of clinical diagnostic significance.

173. Answer (3)

**Hint:** A straight tube extending up to the mid-thoracic cavity.

**Sol.:** Trachea is a straight tube extending up to the mid-thoracic cavity, which divides at the level of 5<sup>th</sup> thoracic vertebra into a right and left primary bronchi.

174. Answer (3)

**Hint:** Aquatic arthropods respire through gills.

**Sol.:** Special vascularised structures called gills (branchial respiration) are used by most of the aquatic arthropods and molluscs whereas vascularised bags called lungs (pulmonary respiration) are used by the terrestrial forms for the exchange of gases. Among vertebrates, fishes use gills whereas amphibians, reptiles, birds and mammals respire through lungs. Amphibians like frogs can respire through their moist skin also.

175. Answer (2)

**Hint:** AV node generates action potential  $< 70 - 75 \text{ min}^{-1}$ .

**Sol.:** A patch of nodal tissue is present in the right upper corner of the right atrium called SA node. Another mass of this tissue is present in lower left corner of the right atrium called AV node.

The number of action potentials that could be generated in a minute vary at different parts of the nodal system. SA node acts as pacemaker by generating maximum number of action potentials.

AV node delays the impulse to facilitate the complete emptying of atria. So, removal of it will lead to simultaneous contraction of chambers.

176. Answer (3)

**Hint:** Cardiac output of a healthy individual is 5 L/minute.

**Sol.:** About 70 mL of blood is pumped out by each ventricle during a cardiac cycle and it is called the stroke or beat volume.

Human circulatory system, also called the blood vascular system consists of a muscular chambered heart, a network of closed branching blood vessels and blood, the fluid which is circulated. Chordae tendineae are found in ventricles.

177. Answer (1)

**Hint:** Veins usually carry deoxygenated blood.

**Sol.:** Arterial blood typically has higher pH than venous blood. The average arterial pH is around 7.41, while the average venous pH is around 7.15. The difference is primarily due to higher levels of carbon dioxide and other metabolic waste products in venous blood.

178. Answer (1)

**Hint:** Alveoli is site of actual diffusion of  $O_2$  and  $CO_2$ .

**Sol.:** The part starting with the external nostrils up to the terminal bronchioles constitute the conducting part whereas the alveoli and their ducts form the respiratory or exchange part of the respiratory system. The conducting part transports the atmospheric air to the alveoli, clears it from foreign particles, humidifies and also brings the air to body temperature. Exchange part is the site of actual diffusion of  $O_2$  and  $CO_2$  between blood and atmospheric air.

179. Answer (3)

**Hint:**  $RV = TLC - VC$

**Sol.:** **Residual Volume:** Volume of air remaining in the lungs even after a forcible expiration. This averages 1100 mL to 1200 mL.

**Vital Capacity:** The maximum volume of air a person can breathe in after a forced expiration.

**Tidal Volume:** Volume of air inspired or expired during a normal respiration.

180. Answer (3)

**Hint:** Person with anti-B antibodies in blood plasma.

**Sol.:**

Blood Group	Antigens on RBCs	Antibodies in Plasma	Donor's Group
A	A	anti-B	A, O
B	B	anti-A	B, O
AB	A, B	nil	AB, A, B, O
O	nil	anti-A, B	O



## All India Aakash Test Series for NEET - 2026

**TEST - 2 (Code-F)**[Click here for Code-E Sol.](#)

Test Date : 30/11/2025

**ANSWERS**

1. (4)	37. (1)	73. (1)	109. (3)	145. (1)
2. (3)	38. (1)	74. (4)	110. (2)	146. (1)
3. (2)	39. (4)	75. (4)	111. (2)	147. (4)
4. (4)	40. (2)	76. (2)	112. (4)	148. (4)
5. (2)	41. (2)	77. (2)	113. (2)	149. (3)
6. (3)	42. (4)	78. (3)	114. (2)	150. (2)
7. (3)	43. (3)	79. (4)	115. (2)	151. (1)
8. (3)	44. (4)	80. (1)	116. (1)	152. (3)
9. (2)	45. (3)	81. (2)	117. (2)	153. (2)
10. (3)	46. (3)	82. (1)	118. (4)	154. (2)
11. (4)	47. (1)	83. (3)	119. (2)	155. (4)
12. (1)	48. (4)	84. (4)	120. (3)	156. (3)
13. (1)	49. (4)	85. (2)	121. (2)	157. (4)
14. (2)	50. (1)	86. (1)	122. (4)	158. (4)
15. (2)	51. (3)	87. (1)	123. (3)	159. (2)
16. (3)	52. (3)	88. (1)	124. (3)	160. (3)
17. (4)	53. (1)	89. (3)	125. (2)	161. (3)
18. (1)	54. (3)	90. (2)	126. (1)	162. (3)
19. (2)	55. (3)	91. (3)	127. (4)	163. (4)
20. (2)	56. (4)	92. (1)	128. (3)	164. (4)
21. (2)	57. (3)	93. (1)	129. (3)	165. (1)
22. (4)	58. (3)	94. (2)	130. (4)	166. (2)
23. (4)	59. (3)	95. (3)	131. (4)	167. (4)
24. (3)	60. (4)	96. (3)	132. (2)	168. (3)
25. (1)	61. (3)	97. (1)	133. (3)	169. (1)
26. (3)	62. (2)	98. (4)	134. (1)	170. (4)
27. (1)	63. (4)	99. (3)	135. (3)	171. (3)
28. (3)	64. (3)	100. (3)	136. (3)	172. (1)
29. (4)	65. (1)	101. (1)	137. (3)	173. (1)
30. (2)	66. (2)	102. (1)	138. (1)	174. (1)
31. (2)	67. (4)	103. (4)	139. (1)	175. (4)
32. (4)	68. (3)	104. (4)	140. (3)	176. (1)
33. (3)	69. (2)	105. (2)	141. (2)	177. (2)
34. (2)	70. (2)	106. (1)	142. (3)	178. (3)
35. (1)	71. (2)	107. (1)	143. (3)	179. (1)
36. (4)	72. (3)	108. (4)	144. (1)	180. (3)

# HINTS & SOLUTIONS

## [PHYSICS]

1. Answer (4)

**Hint:** Minimum force  $F$  is required when  $f_{\max}$  is equal to  $mg$ .

**Sol.:**  $f_{\max} = mg$

$$\mu F = mg$$

$$\mu = \left(\frac{100}{200}\right) = \frac{1}{2}$$

2. Answer (3)

**Hint:**  $v_m = \sqrt{\mu_s Rg}$

**Sol.:**  $v_m = \sqrt{\frac{1}{2} \times 80 \times 10} = \sqrt{400} = 20 \text{ m/s}$

3. Answer (2)

**Hint:** Since  $u < \sqrt{5gl}$ , so it does not complete the circle. It slacks in between.

**Sol.:** Let at point  $B$ , string slacks

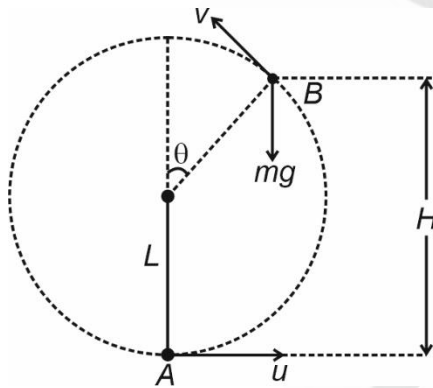

Apply energy conservation between point A and B.

$$U_A + k_A = U_B + k_B$$

$$\Rightarrow 0 + \frac{1}{2}mu^2 = mgL(1 + \cos\theta) + \frac{1}{2}mv_B^2$$

$$\Rightarrow \frac{u^2}{2} = gL(1 + \cos\theta) + \frac{v_B^2}{2}$$

$$\Rightarrow \frac{4gL}{2} = gL(1 + \cos\theta) + \frac{v_B^2}{2}$$

$$\Rightarrow 2gL = gL(1 + \cos\theta) + \frac{v_B^2}{2}$$

$$\Rightarrow \sqrt{2gL(1 - \cos\theta)} = v_B$$

Now at point B,

$$T + mg\cos\theta = \frac{mv_B^2}{L}$$

$\Rightarrow$  Put  $T = 0$ , because it slacks at that point

$$g\cos\theta = \frac{2gL(1 - \cos\theta)}{L}$$

$$\Rightarrow g\cos\theta = (2 - 2\cos\theta)g$$

$$\Rightarrow 3\cos\theta = 2$$

$$\cos\theta = \frac{2}{3}$$

$$H = L + L\cos\theta$$

$$H = L + \frac{2L}{3}$$

$$H = \frac{5L}{3}$$

4. Answer (4)

**Hint & Sol.:** Friction force also acts when there is tendency of relative motion. Hence statement I is incorrect. Raising the outer edge of a curved road above the inner edge to help vehicles negotiate the curve safely is called banking of the road.

5. Answer (2)

**Hint:** Only friction force is responsible for motion of block B

**Sol.:** For whole system

$$F = mra$$

$$a = \left(\frac{F}{m_A + m_B}\right)$$

$$a = \left(\frac{90}{5 + 10}\right) = 6 \text{ m/s}^2$$

For block B

$$f = m_B \times a$$

$$= 10 \times 6 = 60 \text{ N}$$

6. Answer (3)

**Hint:**  $F = \frac{dP}{dt}$

**Sol.:** From  $t = 0$  to  $t = 6$ ,

$$\frac{dP}{dt} = 0$$

From  $t = 6$  to  $t = 10$ ,

$$\frac{dP}{dt} = -ve \text{ (constant)}$$

7. Answer (3)

**Hint:**  $F_{\text{total}} = M_{\text{net}} \times a$

**Sol.:**  $F_{\text{net}} = 3mg - \mu \times 2mg - \mu mg$

$$F_{\text{net}} = 3mg(1 - \mu)$$

$$a = \frac{F_{\text{net}}}{M} = \frac{3mg(1 - \mu)}{6m} = \frac{g(1 - \mu)}{2}$$

8. Answer (3)

**Hint:** Impulse = change in momentum

**Sol.:**  $I = \Delta P = (10t^2 - 4t)$

$$10t^2 - 4t = 0$$

$$t = 0, t = \frac{2}{5} \text{ s}$$

9. Answer (2)

**Hint:** Since the speed of vehicle is less than optimum speed. Therefore, friction acts in upward direction.

**Sol.:** Banking angle,  $\tan \theta = \frac{v_0^2}{rg} = \frac{400}{100 \times 10} = 0.4$

$$\Rightarrow \tan \theta = 0.4 \Rightarrow \theta = 22^\circ$$

Now, when  $v = 15 \text{ ms}^{-1}$ , friction is directed upward

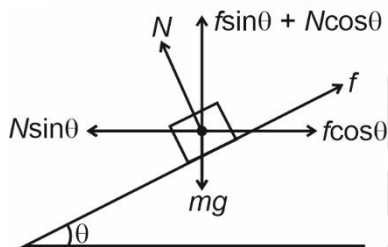

$\Rightarrow$  The vehicle has a tendency to slip in and friction is directed upwards

$$\therefore N \sin \theta - f \cos \theta = \frac{mv^2}{R}$$

and  $N \cos \theta + f \sin \theta = mg$   
eliminating  $N$ , we get

$$f[\tan \theta \sin \theta + \cos \theta] = mg \tan \theta - \frac{mv^2}{R}$$

$$f \left[ \frac{\sin^2 \theta + \cos^2 \theta}{\cos \theta} \right] = mg \tan \theta - \frac{mv^2}{R}$$

$$\Rightarrow f = \left( mg \tan \theta - \frac{mv^2}{R} \right) \cos \theta$$

$$= \left( 500 \times 10 \times 0.4 - \frac{500 \times 225}{100} \right) 0.93$$

$$= (2000 - 1125) \times 0.93$$

$$= 813.75 \text{ N}$$

10. Answer (3)

**Hint:** Angle between tangential acceleration and net acceleration,  $\theta = \tan^{-1} \left( \frac{a_c}{a_t} \right)$ .

**Sol.:**  $\omega = \omega_0 + \alpha t$

$$\omega_t = 2 + 1 \times 2 = 4 \text{ rad/s}$$

$$a_c = \omega^2 r = 16 \times 4 = 64 \text{ m s}^{-2}$$

$$\text{and } a_t = \alpha r = 1 \times 4 = 4 \text{ m s}^{-2}$$

$$\tan \theta = \frac{a_c}{a_t} = \frac{64}{4} = 16$$

$$\theta = \tan^{-1}(16)$$

11. Answer (4)

**Hint:** Net force,  $F = \frac{dP}{dt}$

**Sol.:**  $F = \frac{d}{dt}(m v n)$

$$40 = \frac{dn}{dt} \times 100 \times 50 \times 10^{-3}$$

$$\frac{dn}{dt} = 8$$

12. Answer (1)

**Hint:** Use constraint relation.

**Sol.:**  $a_2 T - 2T a_1 = 0$

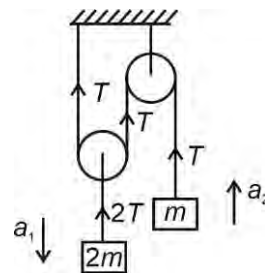

$$a_2 = 2a_1$$

13. Answer (1)

**Hint:** Use formula,  $F_{th} = v_r \frac{dm}{dt}$

**Sol.:**  $F_{th} = v_r \frac{dm}{dt}$

$\Rightarrow 2000 = 180 \times \frac{dm}{dt}$

$\Rightarrow \frac{dm}{dt} = \frac{100}{9} \text{ kg/s}$

14. Answer (2)

**Hint:**  $F_{net} = ma$  and  $T_1 = 2T$

**Sol.:**

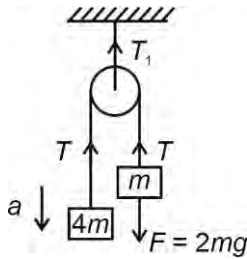

$4mg - T = 4ma \dots(1)$

$T - 3mg = ma \dots(2)$

on solving equation (1) and (2)

$\therefore mg = 5ma$

$a = \left(\frac{g}{5}\right)$

on block of mass  $m$ ,

$T = 3mg + \frac{mg}{5} = \frac{16mg}{5}$

$T_1 = 2T = \frac{32mg}{5}$

15. Answer (2)

**Hint:**  $F_{net}$  along the inclined plane is zero.

**Sol.:**  $f - mg\sin\theta = 0$

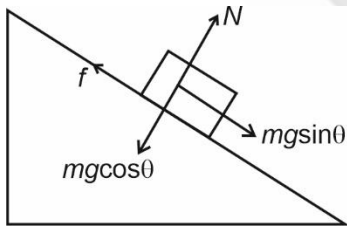

$\mu_k mg\cos\theta = mg\sin\theta$

$\mu_k = \tan\theta = \tan 30^\circ = \frac{1}{\sqrt{3}}$

16. Answer (3)

**Hint:** Books are at rest, therefore net force will be zero on each book

**Sol.:** FBD of B book :

Consider books A and B as a system.

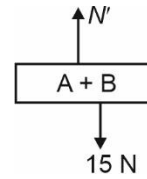

$F_{net} = 0$

$N' - 15 = 0$

$N' = 15 \text{ N upward}$

17. Answer (4)

**Hint:** For maximum acceleration, the tension in the string will be equal to its breaking strength.

**Sol.:**  $T - mg = ma$

$3mg - mg = ma$

$a = 2g$

18. Answer (1)

**Hint & Sol.:** For 15 kg block :  $F_{net} = ma$

$kx = 15 \times 5$

$kx = 75 \text{ N}$

$100x = 75$

$\Rightarrow x = \frac{3}{4} \text{ m}$

For 30 kg block

$180 - kx = 30 \times a$

$180 - 75 = 30a$

$a = \frac{105}{30} = 3.5 \text{ m/s}^2$

Net force on 30 kg block :

$F = 180 - 75 = 105 \text{ N}$

19. Answer (2)

**Hint:** Sit on the wedge and analyse the FBD of the block.

**Sol.:**  $F_{net} = 0$  in  $y$  direction

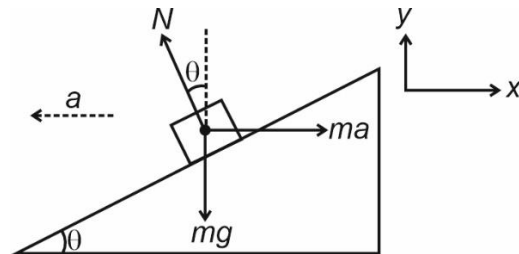

$\therefore N\cos\theta = mg$

20. Answer (2)

**Hint:** A body moving with constant velocity, has constant linear momentum.

$$\text{Sol.: } \frac{d\vec{P}}{dt} = 0 \Rightarrow \vec{F}_{\text{net}} = 0$$

$$\vec{P} = \text{constant}$$

$$\vec{v} = \text{constant}$$

21. Answer (2)

**Hint & Sol.:**  $T_1 = (m_B + m_C) a$

$$T_2 = (m_C) a$$

$$\frac{T_1}{T_2} = \frac{(m + 3m)}{3m} = \frac{4}{3}$$

22. Answer (4)

**Hint:** Both the balls are identical and collision is elastic, so velocity will get interchanged along line of collision.

$$\text{Sol.: } v_B = v \cos 30^\circ$$

$$= 20\sqrt{3} \times \frac{\sqrt{3}}{2} = 30 \text{ m/s}$$

$$KE = \frac{1}{2}mv^2$$

$$= \frac{1}{2}(0.1) \times (30)^2 = 45 \text{ J}$$

23. Answer (4)

**Hint & Sol.:** All the given statements are correct with regards to non-conservative force.

24. Answer (3)

**Hint & Sol.:** Collision is perfectly inelastic so there will be loss of kinetic energy and that loss in kinetic energy will result in increase in temperature. Linear momentum of the system remains conserved.

25. Answer (1)

**Hint:**  $W_{\text{ext}} = \Delta U$

$$\text{Sol.: } U_i = \frac{1}{2}kx^2$$

$$U_f = \frac{1}{2}k(y+x)^2$$

$$W = \frac{1}{2}k(y+x)^2 - \frac{1}{2}kx^2$$

$$= \frac{1}{2}k(y^2 + x^2 + 2yx - x^2)$$

$$= \frac{1}{2}ky(y+2x)$$

26. Answer (3)

**Hint & Sol.:** An object is said to be in stable equilibrium, if on slight displacement from equilibrium position and when released, it comes back to its original position.

27. Answer (1)

**Hint & Sol:** In compression or expansion, energy stored is  $U = \frac{1}{2}kx^2$

When work is done against the spring force, this gets stored as potential energy.

28. Answer (3)

**Hint:** Coefficient of restitution

$$= \frac{\text{Velocity of separation}}{\text{Velocity of approach}}$$

$$\text{Sol.: } e = \frac{v_1 - u}{3u + u}$$

$$1 = \frac{v_1 - u}{4u}$$

$$\Rightarrow v_1 = 5u$$

29. Answer (4)

**Hint & Sol.:**  $v = \sqrt{2gx}$

$$k = \frac{1}{2}m \times 2gx$$

$$k \propto x$$

30. Answer (2)

**Hint:** Apply energy conservation principle.

**Sol.:** Only conservative force is acting on the block, therefore total mechanical energy remains conserved.

$$(TME)_A = (TME)_B$$

$$mg(5h) = mg(2h) + \frac{1}{2}mv^2$$

$$v = \sqrt{6gh}$$

$$\text{At point B : } N + mg = \frac{mv^2}{R} \Rightarrow N + mg = \frac{m}{h} \times 6gh$$

$$N = 5mg$$

31. Answer (2)

**Hint:**  $v = \frac{dx}{dt}$  and  $K = \frac{1}{2}mv^2$

$$\text{Sol.: } x = 2t^2 + t^3$$

$$v = 4t + 3t^2$$

$$v_f = 4 \times 2 + 3 \times 4 = 20 \text{ m/s}$$

$$v_i = 4 + 3 = 7 \text{ m/s}$$

$$\Delta K = \frac{1}{2}m(v_f^2 - v_i^2)$$

$$= 2(400 - 49) = 702 \text{ J}$$

32. Answer (4)

**Hint & Sol.:** When two bodies of same mass undergo head-on elastic collision, then their velocity, momentum and kinetic energy will be interchanged.

33. Answer (3)

$$\text{Hint: } \vec{F}_{\text{avg}} = \left( \frac{\Delta \vec{P}}{\Delta t} \right)$$

**Sol.:** In vertical direction,  $\vec{P}_i = -mu \cos 60^\circ \hat{j}$

$$= -\frac{1}{4} \times 10 \times \frac{1}{2} \hat{j}$$

$$= \left( \frac{-5}{4} \hat{j} \right) \text{ kg m s}^{-1}$$

$$\vec{P}_f = me u \cos 60^\circ \hat{j}$$

$$= \left( \frac{1}{4} \times \frac{1}{2} \times 10 \times \frac{1}{2} \right) \hat{j}$$

$$= \left( \frac{5}{8} \hat{j} \right) \text{ kg m s}^{-1}$$

$$|\Delta \vec{P}| = \frac{5}{4} + \frac{5}{8} = \frac{15}{8} \text{ kg m s}^{-1}$$

$$F_{\text{avg}} = \frac{\Delta P}{\Delta t}$$

$$= \frac{\frac{15}{8}}{\frac{1}{2}} = \frac{15}{4} \text{ N}$$

34. Answer (2)

**Hint:** Use formula  $W = \int P dt$

**Sol.:**  $W = \int P dt$

$$= \int_1^3 (3t^2 + 2t + 1) dt$$

$$= [t^3 + t^2 + t]_1^3$$

$$= 27 + 9 + 3 - 3 = 36 \text{ J}$$

35. Answer (1)

**Hint:**  $W = \int \vec{F} \cdot d\vec{r}$

**Sol.:**  $\vec{F} = (2x\hat{i} + 2\hat{j}) \text{ N}$

$$d\vec{r} = (dx\hat{i} + dy\hat{j}) \text{ m}$$

$$W = \int_1^3 2x dx + \int_2^4 2 dy$$

$$W = [x^2]_1^3 + [2y]_2^4$$

$$= (9 - 1) + (8 - 4) = 8 + 4 = 12 \text{ J}$$

36. Answer (4)

**Hint & Sol:** Potential energy is defined only for conservative force, it depends on reference point so it may be positive, negative or zero.

37. Answer (1)

**Hint & Sol:**  $P = \vec{F} \cdot \vec{v}$

$$P = Fv \cos 90^\circ = 0$$

38. Answer (1)

**Hint:** Use conservation of mechanical energy

**Sol.:**  $ME_i = ME_f$

$$\frac{1}{2}mv_0^2 = \frac{1}{2}m\left(\frac{v_0}{2}\right)^2 + \frac{1}{2}kx^2$$

$$\frac{3}{4}mv_0^2 = kx^2$$

$$x = \frac{v_0}{2} \sqrt{\frac{3m}{k}}$$

39. Answer (4)

**Hint:**  $W_{\text{net}} = \Delta K$

**Sol.:**  $W_{\text{net}} = W_{\text{mg}} + W_{\text{air}}$

$$W_{\text{mg}} = 0$$

$$|W_{\text{air}}| = \Delta K$$

$$= \left| -\frac{1}{2}mv_i^2 + \frac{1}{2}mv_f^2 \right|$$

$$= \left| -\frac{1}{2}m(\sqrt{2gh})^2 + \frac{1}{2}m\left(\sqrt{\frac{2gh}{3}}\right)^2 \right|$$

$$= \left| -mgh + \frac{mgh}{3} \right|$$

$$= \frac{2mgh}{3}$$

40. Answer (2)

**Hint:** Use work-energy theorem.

**Sol.:**  $W_{\text{net}} = \Delta K$

$$\frac{1}{2}mv^2 = W_{\text{mg}} + W_F$$

$$v^2 = -20 \times 3 + 40 \times 4$$

$$v^2 = 160 - 60 = 100$$

$$v = 10 \text{ m/s}$$

41. Answer (2)

**Hint:** Use formula  $W = \vec{F} \cdot \vec{d}$

**Sol.:**  $\vec{d} = (5 - 2)\hat{i} + (1 - 3)\hat{j} + (3 + 4)\hat{k}$

$$= (3\hat{i} - 2\hat{j} + 7\hat{k}) \text{ m}$$

$$\vec{F} = (2\hat{i} + 2\hat{j} - \hat{k}) \text{ N}$$

$$W = (2\hat{i} + 2\hat{j} - \hat{k}) \cdot (3\hat{i} - 2\hat{j} + 7\hat{k})$$

$$= 6 - 4 - 7 = -5 \text{ J}$$

42. Answer (4)

**Hint & Sol.:** The collision in which the bodies stick together after collision is called perfectly inelastic collision, and in perfectly inelastic collision linear momentum of system is conserved.

43. Answer (3)

**Hint:** Power is defined as rate of change of kinetic energy.

**Sol.:**  $P = \text{constant}$

$$\frac{dK}{dt} = \text{constant}$$

$$\therefore K \propto t$$

44. Answer (4)

**Hint:** Apply  $F_{\text{net}} = 0$  in vertical direction.

**Sol.:**  $\therefore F_{\text{net}} = 0$  in vertical direction

$$\therefore T_2 \sin 37^\circ = 2g$$

$$T_2 \times \frac{3}{5} = 20$$

$$T_2 = \frac{100}{3} \text{ N}$$

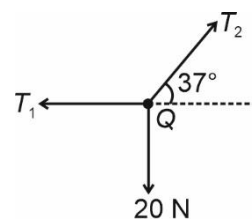

45. Answer (3)

**Hint & Sol.:**  $\vec{P} + \vec{Q} = \vec{R}$

$$\vec{Q} = \vec{R} - \vec{P}$$

$$\vec{Q} \cdot \vec{Q} = \vec{R} \cdot \vec{Q} - \vec{P} \cdot \vec{Q}$$

$$Q^2 = \vec{R} \cdot \vec{Q} - \vec{P} \cdot \vec{Q}$$

$$Q = \sqrt{\vec{R} \cdot \vec{Q} - \vec{P} \cdot \vec{Q}}$$

## [CHEMISTRY]

46. Answer (3)

**Hint:** Atomic weight of middle element is about half way between the atomic weights of other two elements in Dobereiner's Triad if elements are arranged in increasing atomic weights.

**Sol.:** Some example of triad are as

- Li, Na, K
- Ca, Sr, Ba
- Cl, Br, I

47. Answer (1)

**Hint:** Mendeleev predicted existence and position in periodic table for some undiscovered elements.

**Sol.:** Eka Aluminium – Ga

Eka Silicon – Ge

48. Answer (4)

**Hint:** According to Mendeleev's periodic law, the properties of the elements are a periodic function of their atomic weights.

**Sol.:** According to Modern periodic law, the properties of the elements are periodic functions of their atomic numbers.

49. Answer (4)

**Hint:** Ce is first lanthanoid which is introduced in 6<sup>th</sup> period.

**Sol.:** • Group 3 of longest groups with 32 elements.

- Seventh period can have maximum 32 elements.
- Halogens from group 17 are most electronegative.
- 3<sup>rd</sup> and 4<sup>th</sup> period have 8 and 18 elements respectively.

50. Answer (1)

**Hint:** Element with  $Z > 86$  belongs to period 7.

**Sol.:** For element with  $Z = 113$

Period = 7

Group = 13

51. Answer (3)

**Hint:** Y is the first element in which electron is introduced in 4d subshell.

**Sol.:** Cobalt, Rhodium and Iridium belong to 9<sup>th</sup> group in modern periodic table.

52. Answer (3)

**Hint:** Transuranium elements have atomic number greater than 92.

**Sol.:** Atomic number of Np is 93 hence it is a transuranium element.

53. Answer (1)

**Hint:** In order to convert any element to cation electron from outermost shell is removed.

**Sol.:** It is Ge which belongs to 4<sup>th</sup> period and 14<sup>th</sup> group.

54. Answer (3)

**Hint:** 101 is atomic number of Mendelevium.

**Sol.:** 103 is atomic number of Lawrencium.

105 is atomic number of Dubnium.

107 is atomic number of Bohrium.

55. Answer (3)

**Hint:** Element from atomic number 87 to 118 will be present in 7<sup>th</sup> period of periodic table.

**Sol.:** IUPAC naming 1  $\rightarrow$  un

2  $\rightarrow$  bi

4  $\rightarrow$  quad

Name  $\Rightarrow$  Unbiquadium.

56. Answer (4)  
**Hint:** Chlorine is a non-metal.  
**Sol.:** Antimony is a semi-metal  
 Rhenium is a transition metal  
 Promethium is a lanthanoid.
57. Answer (3)  
**Hint:** On moving down the group generally atomic radius increases.  
**Sol.:** On moving left to right in a period, atomic radius generally decreases.  
 $Li > Be > B > C$
58. Answer (3)  
**Hint:** Energy required to remove an electron from an isolated gaseous atom in its ground state is known as ionisation enthalpy.  
**Sol.:** Noble gases have stable electronic configuration so they have large positive electron gain enthalpies.
59. Answer (3)  
**Hint:** As the positive charge increases atomic radius decreases for isoelectronic species.  
**Sol.:** • For any element successive ionisation energy increases.  
 • Formation of multinegative anion  $O^{2-}$ , is always an endothermic process.  
 • During formation of cation, electron is removed from outermost shell.
- Hence for conversion of Sc to  $Sc^+$ , from Sc, electron will be removed from 4s subshell.
60. Answer (4)  
**Hint:** Group 16 elements are chalcogens.  
**Sol.:** For chalcogens decreasing order of electronegativity is  
 $O > S > Se > Te$
61. Answer (3)  
**Hint:** 3<sup>rd</sup> period element has more negative electron gain enthalpy than 2<sup>nd</sup> period element of same group.  
**Sol.:** For group 16, the correct order of negative electron gain enthalpy is as follows.  
 $S > Se > Te > O$
62. Answer (2)  
**Hint:** On moving left to right in a period, ionisation enthalpy generally increases.  
**Sol.:** • Be has more ionisation enthalpy than B due to more penetrating effect.  
 • N has more ionisation enthalpy than O due to half filled stable configuration.
63. Answer (4)  
**Hint & Sol.:**  $Na^+$ ,  $Mg^{2+}$  and  $Al^{3+}$  all are positive isoelectronic species. So, greater is the charge, smaller will be the size.

64. Answer (3)  
**Hint:** For removal of one electron from stable electronic configuration excessive amount of energy is required hence an abnormal jump in successive ionisation energy will be observed.  
**Sol.:** Number of outermost shell electrons is equal to the number of successive IPs before abnormal jump.

Successive IPs	Number of outer most shell electron(s)	Configuration
x, 2x, 5x, 125x, 130x	3	$1s^2, 2s^2, 2p^6, 3s^2, 3p^1$
y, 30y, 33y, 37y, 43y	1	$1s^2, 2s^2, 2p^6, 3s^1$
z, 5z, 90z, 94z, 99z	2	$1s^2, 2s^2, 2p^6, 3s^2$
p, 4p, 9p, 17p, 102p	4	$1s^2, 2s^2, 2p^6, 3s^2, 3p^2$

65. Answer (1)  
**Hint:** Valence of group 1 element is 1.  
**Sol.:** Valence of group 2 element is 2.  
 Valence of group 15 element is 3, 5.  
 Valence of group 14 element is 4.
66. Answer (2)  
**Hint & Sol.:** p-block of modern periodic table contains metal, nonmetal and metalloids.
67. Answer (4)  
**Hint:** If H-bond is formed within the molecule it is considered as intramolecular hydrogen bond.

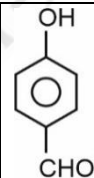
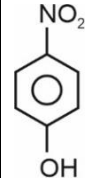
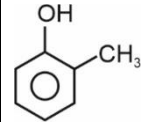
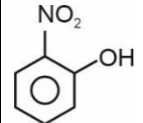
	→	Intermolecular H-bond
	→	Intermolecular H-bond
	→	Intermolecular H-bond
	→	Intramolecular H-bond

68. Answer (3)

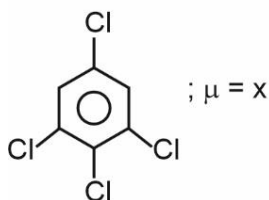
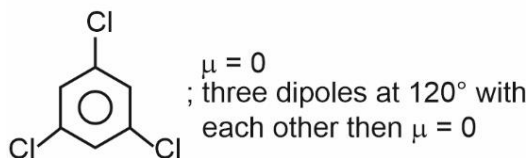
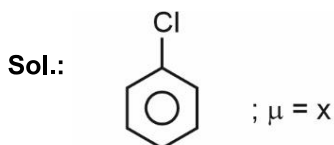
**Hint:** Dipole moment of a molecule is vector sum of all the bond moments.

69. Answer (2)

**Hint:**  $B_2$  molecule has single  $\pi$  bond.

**Sol.:**  $N_2 \rightarrow 1\sigma$  and  $2\pi$  bonds

 $O_2 \rightarrow 1\sigma$  and  $1\pi$  bonds

 $Li \rightarrow 1\sigma$  bond

 $C_2 \rightarrow 2\pi$  bonds.

70. Answer (2)

**Hint:**  $O_2$  has two unpaired electrons in  $\pi$  antibonding molecular orbital.

**Sol.:** • Magnetic moment  $\mu = \sqrt{n(n+2)}$  BM

$$= \sqrt{2(2+2)} \text{ BM}$$

$$= 2.82 \text{ BM}$$

 • During conversion of  $N_2$  to  $N_2^+$  electron is removed from  $\sigma 2p_z$  orbital.

71. Answer (2)

**Hint:** % Ionic character =  $\frac{\mu_{\text{observed}}}{\mu_{\text{calculated}}} \times 100$ 
**Sol.:**  $\mu_{\text{calculated}} = q \times d$ , [Here  $q = 4.8 \times 10^{-10}$  esu]

$$= 4.8 \times 10^{-10} \text{ esu} \times 99 \times 10^{-10} \text{ cm}$$

$$= 4.75 \times 10^{-18} \text{ esu} - \text{cm}$$

$$\mu_{\text{observed}} = 1.88 \text{ D}$$

$$= 1.88 \times 10^{-18} \text{ esu} - \text{cm}$$

$$\% \text{ Ionic character} = \frac{1.88 \times 10^{-18}}{4.75 \times 10^{-18}} \times 100$$

$$= 39.57\%$$

72. Answer (3)

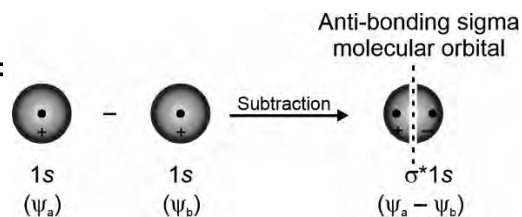
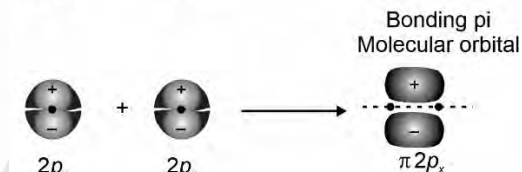
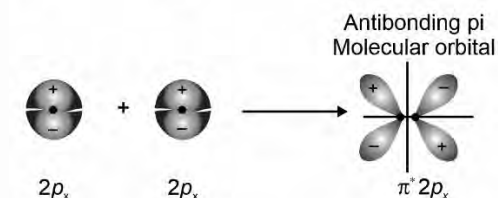
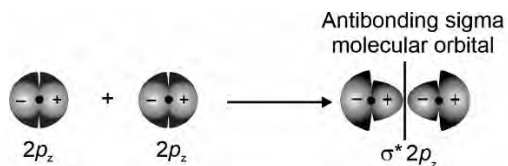
**Hint:**

**Sol.:**

73. Answer (1)

**Hint & Sol.:** The combining atomic orbitals must have the same or nearly the same energy. This means that  $1s$  orbital can combine with another  $1s$  orbital but not with  $2s$  orbital because the energy of  $2s$  orbital is appreciably higher than that of  $1s$  orbital.

74. Answer (4)

**Hint & Sol.:** Orbital involved in  $dsp^2$  hybridisation are  $\underbrace{d_{x^2-y^2}}_{\text{inner}} + s + p_x + p_y$ .

75. Answer (4)

**Hint:** Nitrogen in  $NH_3$  is  $sp^3$  hybridised.

**Sol.:**  $ClO_4^- - sp^3$ 
 $PCl_3 \rightarrow sp^3$ 
 $[Co(NH_3)_6]^{3+} - d^2sp^3$ 

76. Answer (2)

**Hint & Sol.:** The hybrid orbitals are always equivalent in energy and shape.

77. Answer (2)

**Hint:** When orbitals of two atoms come close to form bond, their overlap may be positive, negative or zero depending upon the sign (phase) and direction of orientation of amplitude of orbital wave function in space.

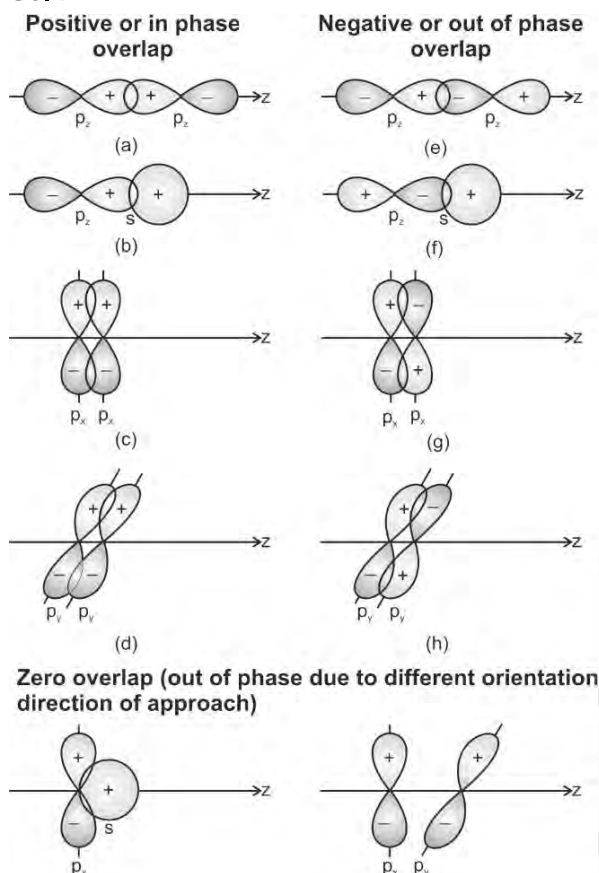
**Sol.:**

78. Answer (3)

**Hint:** PCl<sub>5</sub> is trigonal bipyramidal molecule with sp<sup>3</sup>d hybridisation.**Sol.:** Axial bonds are longer than equatorial bonds.

$$\mu_{\text{net}} = 0$$

79. Answer (4)

**Hint:** Shape of SO<sub>2</sub> is bent.**Sol.:** Shape of ClF<sub>3</sub> is T-shapeShape of SF<sub>4</sub> is see-sawShape of XeF<sub>4</sub> is square planar

80. Answer (1)

**Hint & Sol.:** The repulsive interaction of electron pairs decrease in the order:

Lone pair (lp) – Lone pair (lp) &gt; Lone pair (lp) – Bond pair (bp) &gt; Bond pair (bp) – Bond pair (bp)

81. Answer (2)

**Hint:** H<sub>2</sub>O has very high dipole moment.**Sol.:**

Molecule	Dipole moment
H <sub>2</sub> O	1.85 D
HCl	1.07 D
NH <sub>3</sub>	1.47 D

82. Answer (1)

**Hint:** The molecule that shows resonance cannot be depicted by a single Lewis structure.**Sol.:** The canonical forms have no real existence.

83. Answer (3)

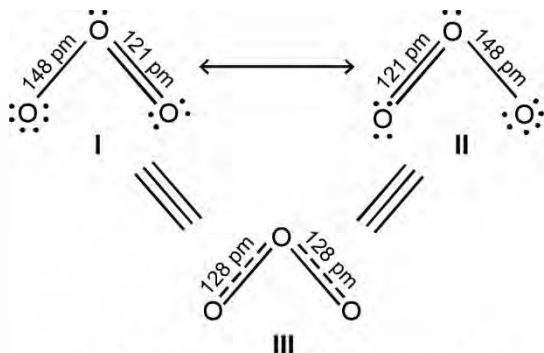
**Hint:** Isoelectronic molecules and ions have identical bond order; for example, F<sub>2</sub> and O<sub>2</sub><sup>2-</sup> have bond order 1. N<sub>2</sub>, CO and NO<sup>+</sup> have bond order 3.**Sol.:**Resonance in the O<sub>3</sub> molecule

- BE of H<sub>2</sub> is 435.8 kJ mol<sup>-1</sup> while BE of HCl is 431 kJ mol<sup>-1</sup>.

84. Answer (4)

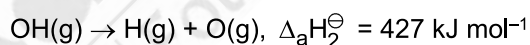
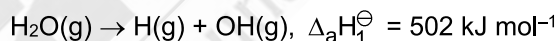
**Hint & Sol.:**

85. Answer (2)

**Hint:** Generally as size of atom decreases, bond length also decreases.**Sol.:**

Bond type	Bond length
C – H	107 pm
N – O	136 pm
C – O	143 pm

86. Answer (1)

**Hint:** Lattice energy increases with magnitude of the charge and decrease with size of ions.**Sol.:** For common anion, as charge of cation increase, lattice energy also increase.Order : Na<sub>2</sub>O < MgO < Al<sub>2</sub>O<sub>3</sub>

87. Answer (1)

**Hint:** Formal charge (F.C.) on an atom in a Lewis structure = [total number of valence electrons in the free atom] – [total number of non-bonding (lone pair) electrons] – (1/2) [total number of bonding (shared) electrons].

**Sol.:** For O - 1  $\Rightarrow$  FC =  $6 - 4 - \frac{1}{2}$  (4)

= 0

For O - 2  $\Rightarrow$  FC =  $6 - 2 - \frac{1}{2}$  (6)

= +1

For O - 3  $\Rightarrow$  FC =  $6 - 6 - \frac{1}{2}$  (2)

= -1

88. Answer (1)

**Hint:** Electrovalence is equal to unit charge on the ion.

**Sol.:**

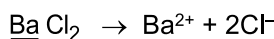
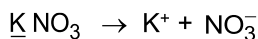
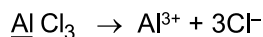
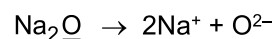

89. Answer (3)

**Hint:** B has 6 electrons in outermost shell in  $\text{BH}_3$  molecule.

**Sol.:** In  $\text{H}_2\text{SO}_4$ , there are 12 electrons around the S atom hence it is termed as expanded octet.

90. Answer (2)

**Hint:** Group 1 elements form basic oxide.

**Sol.:**  $\text{Al}_2\text{O}_3$  is amphoteric  $\text{Na}_2\text{O}$  is basic,  $\text{SiO}_2$  is acidic and  $\text{N}_2\text{O}$  is neutral oxide.

## [BOTANY]

91. Answer (3)

**Hint:** Sporozoans do not have any locomotory structure.

**Sol.:** *Plasmodium* is a sporozoan and it lacks flagella or any locomotory structure.

92. Answer (1)

**Hint:** In members of phycmycetes, asexual reproduction takes place by zoospores or aplanospores.

**Sol.:** According to R.H. Whittaker's classification, kingdom plantae includes autotrophic organisms. Bladderwort and Venus fly trap are examples of insectivorous plants i.e., partial heterotroph and *Cuscuta* is a parasite, still they are placed in kingdom plantae.

93. Answer (1)

**Hint:** Viruses that infect plant have RNA

**Sol.:** In general, the viruses that infect plants have ssRNA as genetic material.

94. Answer (2)

**Hint:** Sleeping sickness is caused by *Trypanosoma*.

**Sol.:** *Trypanosoma* is a flagellated protozoan. The members of this group are either free living or parasitic.

95. Answer (3)

**Hint:** This organism belongs to dinoflagellates.

**Sol.:** Red dinoflagellates, *Gonyaulax* undergo rapid multiplication, due to which they make the sea appear red.

96. Answer (3)

**Hint:** Mycoplasma is pathogenic in nature.

**Sol.:** Mycoplasma can affect both plants and animals.

97. Answer (1)

**Hint:** They are also involved in the methane production.

**Sol.:** Methanogens are present in the gut of several ruminants such as cows and buffaloes and they are responsible for the production of methane (biogas).

98. Answer (4)

**Hint:** Bacteria are simple in structure and complex in behaviour.

**Sol.:** According to R.H. Whittaker's five kingdom classification, organisms with simple body organization but very complex behaviour are placed under the kingdom Monera.

99. Answer (3)

**Hint:** In lichens, the algal component is known as phycobiont and fungal component as mycobiont, which are autotrophic and heterotrophic respectively.

**Sol.:** In lichens, a mutualistic relationship is observed. The algal component prepares food for fungi and fungi provide shelter and absorb mineral nutrients for its partner.

100. Answer (3)

**Hint:** In the members of both ascomycetes and basidiomycetes an intervening dikaryophase occurs.

**Sol.:** Basidiomycetes lack asexual reproduction. In both ascomycetes and basidiomycetes, meiosis takes place for formation of spores.

101. Answer (1)

**Hint:** Morels and truffles belong to the same class of fungi, i.e., ascomycetes

**Sol.:** Mushroom belongs to basidiomycetes and morels belong to the ascomycetes and they both are edible.

102. Answer (1)

**Hint:** Prions are abnormally folded proteins which cause mad cow disease in cattle

**Sol.:** Viroid lacks protein coat and causes potato spindle tuber disease. It consists of RNA of low molecular weight.

103. Answer (4)

**Hint:** Lotus has apocarpous gynoecium.

**Sol.:** Lotus is multicarpellary, while pea is monocarpellary.

104. Answer (4)

**Sol.:** Lupin is the ornamental plant of family Fabaceae.

105. Answer (2)

**Hint:** The kingdom, whose sole members are bacteria is divided into two different domains in six kingdom classification.

**Sol.:** In three domain system, kingdom Monera is divided into two different domains.

106. Answer (1)

**Hint:** Slime moulds are saprophytic protists, and during unfavourable condition, the plasmodium differentiates and forms the fruiting bodies bearing spores at their tips.

**Sol.:** In slime moulds, the spores possess true walls. They are extremely resistant and survive for many years even under the adverse condition.

107. Answer (1)

**Hint:** T.O. Diener discovered viroids, which are infectious RNA particles and they are devoid of the protein coat.

**Sol.:** Dmitri Ivanowsky (1892) recognised certain microbes as causal organism of the mosaic disease of tobacco. M.W. Beijerinck (1898) demonstrated that the extract of the infected plants of tobacco could cause infection in healthy plants and called the fluid as "*Contagium vivum fluidum*" (infectious living fluid).

W.M. Stanley (1935) showed that viruses could be crystallised and crystals consist largely of proteins.

108. Answer (4)

**Hint:** *Agaricus* belongs to the class basidiomycetes in which vegetative reproduction commonly takes place by fragmentation.

**Sol.:** *Albugo* is a member of phycomycetes in which mycelium is aseptate and coenocytic. *Colletotrichum* belongs to the class deuteromycetes and they are commonly known as imperfect fungi.

*Neurospora* belongs to the class ascomycetes, in which ascospores (sexual spores) are produced endogenously.

109. Answer (3)

**Hint:** Two kingdom system of classification was given by Linnaeus. The proposed two kingdoms are Animalia and Plantae.

**Sol.:** The classification system given by Linnaeus did not distinguish between the eukaryotes and prokaryotes, unicellular and multicellular organisms and photosynthetic (green algae) and non-photosynthetic (fungi) organisms.

110. Answer (2)

**Hint:** A zygospore is formed by the fusion of two gametes in the members of zygomycetes.

**Sol.:** *Neurospora* belongs to the class ascomycetes. Zygospores are formed in the members of zygomycetes.

111. Answer (2)

**Hint:** Asexual spores are absent in club fungi.

**Sol.:** All the given characteristics are true for the members of class Basidiomycetes.

112. Answer (4)

**Hint:** The sexual life cycle of fungi involves the following steps

Plasmogamy → Karyogamy → Meiosis

**Sol.:** These steps occur as:

- (i) Fusion of protoplasts between two motile or non-motile gametes called plasmogamy.
- (ii) Fusion of two nuclei called karyogamy.
- (iii) Meiosis in zygote resulting in haploid spores.

113. Answer (2)

**Hint:** All single celled eukaryotes are put under the kingdom Protista. Euglenoids, slime moulds and members of Protozoa do not have cell wall.

**Sol.:** Euglenoids have pigments identical to higher plants and perform oxygenic photosynthesis, slime moulds are saprophytic in nature.

114. Answer (2)

**Hint:** Cyanobacteria have some specialized cells called heterocyst in which atmospheric nitrogen can be fixed.

**Sol.:** Some cyanobacteria can fix atmospheric nitrogen in specialised cells called heterocyst, while other cells fix CO<sub>2</sub>.

115. Answer (2)

**Hint:** According to R.H Whittaker's, five kingdom classification system, kingdom Animalia includes organisms with tissue/ organ/organ system level of body organization with heterotrophic mode of nutrition only.

**Sol.:** Kingdom Protista has brought together *Chlamydomonas* and *Chlorella* with *Paramecium* and *Amoeba*.

116. Answer (1)

**Hint:** Single ovule, attached to placenta is found in the plants having basal placentation.

**Sol.:** In sunflower, placenta develops at the base of the ovary and it has single ovule attached to the placenta.

117. Answer (2)

**Hint:** When stamens are united into two bundles, then it is called diadelphous condition.

**Sol.:** Diadelphous condition can be represented as A<sub>(n)+(n)</sub>.

118. Answer (4)

**Hint:** Lemon and members of Solanaceae show axile placentation.

**Sol.:** *Argemone* and mustard show parietal placentation. *Primrose* and *Dianthus* show free central placentation.

119. Answer (2)

**Hint:** In cymose inflorescence, basipetal arrangement of flowers is present.

**Sol.:** In cymose inflorescence, the main axis terminates into flower and hence, has a limited growth. In cymose inflorescence, the flowers are borne in the basipetal order.

120. Answer (3)

**Sol:** In the members of Fabaceae eg. Pea marginal placentation is seen.

121. Answer (2)

**Hint:** In China rose, monadelphous condition of stamens is present.

**Sol.:** In China rose, cohesion of stamens is observed. In floral diagram, four floral whorls can be easily distinguished.

122. Answer (4)

**Hint:** Leaf blade is also known as lamina.

**Sol.:** In some leguminous plants, the leaf base may become swollen, which is called the pulvinus. The petiole helps hold the blade to light. Long thin flexible petioles allow leaf blades to flutter in wind. The lamina or the leaf blade is the green expanded part of the leaf with veins and veinlets.

123. Answer (3)

**Hint:** Lily and bean belong to liliaceae and fabaceae family respectively.

**Sol.:** In lily, sepals and petals are not distinguished and perianth is found.

124. Answer (3)

**Hint:** Solanaceae family is commonly known as potato family and it produces endospermous seeds.

**Sol.:** In members of solanaceae, actinomorphic flower, valvate aestivation, epipetalous androecium and axile placentation is present.

125. Answer (2)

**Hint:** In the given structure of the monocot seed, label A is aleurone layer, label B is endosperm, label C is scutellum, label D is plumule and label E is coleorhiza.

**Sol.:** Endosperm is the result of double fertilization. Aleurone layer is proteinaceous in nature. Monocot seed consists of a large and shield shaped cotyledon known as scutellum. The plumule and radicle are enclosed in the sheaths called coleoptile and coleorhiza respectively.

126. Answer (1)

**Hint:** It is the region proximal to the region of meristematic activity towards root cap.

**Sol.:** The cells found in the region of elongation undergo rapid elongation and enlargement and are responsible for the growth of the root in length.

127. Answer (4)

**Hint:** Axillary buds develop at the axil of leaf.

**Sol.:** Axillary buds do not form leaf. Bracts are found at the base of pedicel.

128. Answer (3)

**Hint:** Silk cotton shows the presence of palmately compound leaves.

**Sol.:** In palmately compound leaves, leaflets are attached to a common point, i.e., tip of a petiole.

129. Answer (3)

**Hint:** When shoot apical meristem changes to floral meristem, the apex produces different kind of floral appendages laterally at successive nodes instead of leaves.

**Sol.:** A typical flower has four different kinds of whorls which are arranged successively on the swollen end of the stalk or pedicel called thalamus.

130. Answer (4)

**Hint:** In some leguminous plants, the leaf base swells and is called pulvinus.

**Sol.:** In a monocotyledonous plant, the primary root is short lived and is generally replaced by a number of fine fibrous roots. These roots originate from the base of the stem and constitute the fibrous root system. The seeds obtained are endospermous.

131. Answer (4)

**Hint:** Pericarp is the fruit wall which is thick and fleshy and further differentiated into three layers.

**Sol.:** When pericarp is thick and fleshy, it is differentiated into outer epicarp, the middle mesocarp and the inner endocarp.

132. Answer (2)

**Hint:** Bud may develop into a branch, flower or tendril.

**Sol.:** Bud are not found in axil of leaflets rather found in axil of compound leaf. Internodes of stem and underground stem lack buds.

133. Answer (3)

**Hint:** The outer covering of endosperm separates the embryo by a proteinaceous layer called aleurone layer.

**Sol.:** Aleurone layer is proteinaceous, and it surrounds the nutritive tissue. It is found in the monocotyledonous seeds.

134. Answer (1)

**Hint:** In vexillary aestivation, one large posterior petal is known as standard.

**Sol.:** In members of Fabaceae, two lateral petals form wings, two anterior ones form a keel that encloses stamen and pistil and one large posterior standard petal are found.

135. Answer (3)

**Hint:** Axillary bud has meristematic cells.

**Sol.:** Sepals, petiole and stipule have chlorophyll. Axillary buds lack chlorophyll.

## [ZOOLOGY]

136. Answer (3)

**Hint:** Person with anti-B antibodies in blood plasma.

**Sol.:**

Blood Group	Antigens on RBCs	Antibodies in Plasma	Donor's Group
A	A	anti-B	A, O
B	B	anti-A	B, O
AB	A, B	nil	AB, A, B, O
O	nil	anti-A, B	O

137. Answer (3)

**Hint:**  $RV = TLC - VC$

**Sol.:** **Residual Volume:** Volume of air remaining in the lungs even after a forcible expiration. This averages 1100 mL to 1200 mL.

**Vital Capacity:** The maximum volume of air a person can breathe in after a forced expiration.

**Tidal Volume:** Volume of air inspired or expired during a normal respiration.

138. Answer (1)

**Hint:** Alveoli is site of actual diffusion of  $O_2$  and  $CO_2$ .

**Sol.:** The part starting with the external nostrils up to the terminal bronchioles constitute the conducting part whereas the alveoli and their ducts

form the respiratory or exchange part of the respiratory system. The conducting part transports the atmospheric air to the alveoli, clears it from foreign particles, humidifies and also brings the air to body temperature. Exchange part is the site of actual diffusion of  $O_2$  and  $CO_2$  between blood and atmospheric air.

139. Answer (1)

**Hint:** Veins usually carry deoxygenated blood.

**Sol.:** Arterial blood typically has higher pH than venous blood. The average arterial pH is around 7.41, while the average venous pH is around 7.15.

The difference is primarily due to higher levels of carbon dioxide and other metabolic waste products in venous blood.

140. Answer (3)

**Hint:** Cardiac output of a healthy individual is 5 L/minute.

**Sol.:** About 70 mL of blood is pumped out by each ventricle during a cardiac cycle and it is called the stroke or beat volume.

Human circulatory system, also called the blood vascular system consists of a muscular chambered heart, a network of closed branching blood vessels and blood, the fluid which is circulated. Chordae tendineae are found in ventricles.

141. Answer (2)

**Hint:** AV node generates action potential  $< 70 - 75 \text{ min}^{-1}$ .

**Sol.:** A patch of nodal tissue is present in the right upper corner of the right atrium called SA node. Another mass of this tissue is present in lower left corner of the right atrium called AV node.

The number of action potentials that could be generated in a minute vary at different parts of the nodal system. SA node acts as pacemaker by generating maximum number of action potentials.

AV node delays the impulse to facilitate the complete emptying of atria. So, removal of it will lead to simultaneous contraction of chambers.

142. Answer (3)

**Hint:** Aquatic arthropods respire through gills.

**Sol.:** Special vascularised structures called gills (branchial respiration) are used by most of the aquatic arthropods and molluscs whereas vascularised bags called lungs (pulmonary respiration) are used by the terrestrial forms for the exchange of gases. Among vertebrates, fishes use gills whereas amphibians, reptiles, birds and mammals respire through lungs. Amphibians like frogs can respire through their moist skin also.

143. Answer (3)

**Hint:** A straight tube extending up to the mid-thoracic cavity.

**Sol.:** Trachea is a straight tube extending up to the mid-thoracic cavity, which divides at the level of 5<sup>th</sup> thoracic vertebra into a right and left primary bronchi.

144. Answer (1)

**Hint:** Closure of tricuspid and bicuspid valves produces first heart sound.

**Sol.:** During each cardiac cycle, two prominent sounds are produced which can be easily heard through a stethoscope. The first heart sound (lub) is associated with the closure of the tricuspid and bicuspid valves whereas the second heart sound (dub) is associated with the closure of the semilunar valves. These sounds are of clinical diagnostic significance.

145. Answer (1)

**Hint:** Systemic arteries carry oxygenated blood.

**Sol.:**

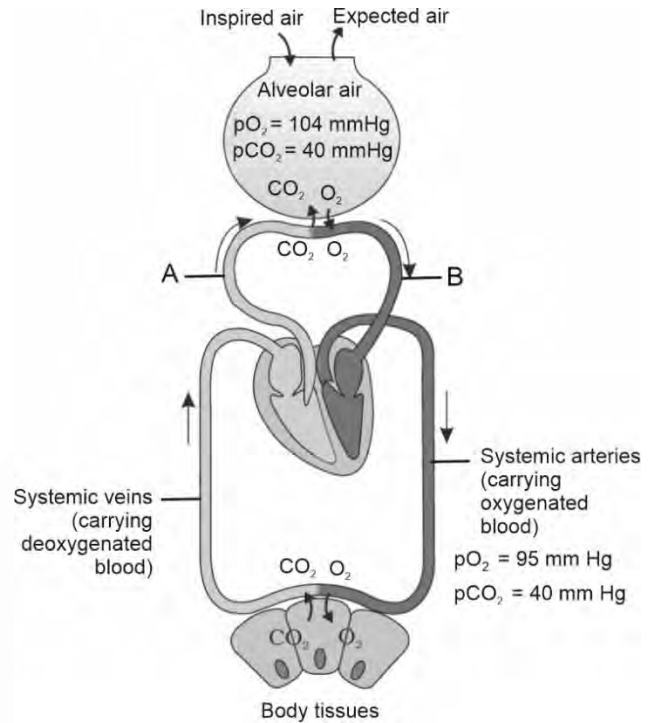

146. Answer (1)

**Hint:** White blood cells.

**Sol.:** Leucocytes are also known as white blood cells (WBC) as they are colourless due to the lack of haemoglobin. They are nucleated and are relatively lesser in number which averages  $6000-8000 \text{ mm}^{-3}$  of blood. Leucocytes are generally short lived. A healthy adult man has on average 5 million to 5.5 million of RBC  $\text{mm}^{-3}$  of blood. Blood normally contains  $1,50,000 - 3,50,000$  platelets  $\text{mm}^{-3}$ .

147. Answer (4)

**Hint:** Vascularised bag-like structures.

**Sol.:** Larynx is a cartilaginous box which helps in sound production. During swallowing, glottis can be covered by thin elastic cartilaginous flap called epiglottis.

Trachea, primary, secondary and tertiary bronchi and initial bronchioles are supported by cartilaginous rings.

148. Answer (4)

**Hint:** Basophils are the least abundant formed element

**Sol.:** Percentage of lymphocytes in total WBCs = 20-25%

Per centage of eosinophils in total WBCs = 2-3%

Per centage of monocytes in total WBCs = 6-8%

Per centage of basophils in total WBCs = 0.5-1%

Per cent of CO<sub>2</sub> transported as carbaminohemoglobin = 20-25%

Per cent of O<sub>2</sub> transported in dissolved state = 3%

Per cent of CO<sub>2</sub> transported in dissolved state = 7%

Per cent of O<sub>2</sub> transported as oxyhaemoglobin = 97%

149. Answer (3)

**Hint:** Lymphocytes are agranulocytes.

**Sol.:** Neutrophils are the most abundant cells (60-65 per cent) of the total WBCs and basophils are the least (0.5-1 per cent) among them. Basophils secrete histamine, serotonin, heparin, etc., and are involved in inflammatory reactions. Neutrophils, eosinophils and basophils are different types of granulocytes, while lymphocytes and monocytes are the agranulocytes.

150. Answer (2)

**Hint:** Asthma is a difficulty in breathing causing wheezing.

**Sol.:**

Heart failure	Heart is not pumping blood effectively enough to meet needs of body
Asthma	Difficulty in breathing due to inflammation of bronchi and bronchioles
Cardiac arrest	Heart stops beating
Emphysema	Alveolar walls are damaged due to which respiratory surface is decreased

151. Answer (1)

**Hint:** Valves prevent backward blood flow.

**Sol.:** The opening of the right and left ventricles into the pulmonary artery and the aorta respectively are guarded with semilunar valves. The valves in heart allow the flow of blood only in one direction *i.e.* from atria to the ventricles and from the ventricles to the pulmonary artery and aorta.

152. Answer (3)

**Hint:** Backbone represents dorsal axis.

**Sol.:** The human lungs are situated in the thoracic chamber, which is anatomically an air-tight chamber. The thoracic chamber is formed dorsally by the vertebral column, ventrally by the sternum, laterally by the ribs and on the lower side by the dome shaped diaphragm.

153. Answer (2)

**Hint:** At tissue site, pCO<sub>2</sub> is high

**Sol.:** At tissue site, where partial pressure of CO<sub>2</sub> is high due to catabolism, CO<sub>2</sub> diffuses into blood (RBCs and plasma) and forms HCO<sub>3</sub><sup>-</sup> and H<sup>+</sup>.

At the alveolar site where pCO<sub>2</sub> is low and pO<sub>2</sub> is high, the reaction proceeds in the opposite direction leading to the formation of CO<sub>2</sub> and H<sub>2</sub>O. Thus, CO<sub>2</sub> trapped as bicarbonate at the tissue level is transported to the alveoli and then released out as CO<sub>2</sub>.

154. Answer (2)

**Hint:** p50 value < 50 mm Hg

**Sol.:** p50 value refers to the partial pressure of oxygen at which haemoglobin is 50% saturated with oxygen. A normal p50 value in humans is typically 25 – 30 mm Hg.

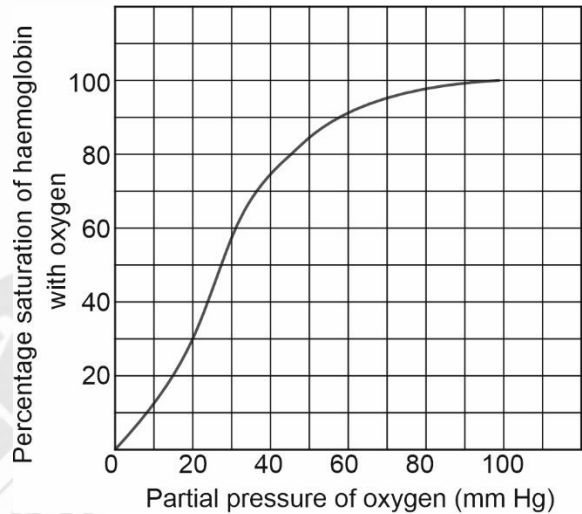

155. Answer (4)

**Hint:** An Rh -ve person if exposed to Rh +ve blood, will form specific antibodies.

**Sol.:**

Blood Group	Antigens on RBCs	Antibodies in Plasma	Donor's Group
A	A	anti-B	A, O
B	B	anti-A	B, O
AB	A, B	nil	AB, A, B, O
O	nil	anti-A, B	O

Another antigen, the Rh antigen similar to one present in Rhesus monkeys, is also observed on the surface of RBCs of majority of humans.

Such individuals are called Rh positive and those in whom this antigen is absent are called Rh negative. An Rh -ve person, if exposed to Rh +ve blood, will form specific antibodies against the Rh antigens. Therefore, Rh group should also be matched before blood transfusions.

156. Answer (3)

**Hint:** Cardiac output = Heart rate  $\times$  stroke volume

**Sol.:** Cardiac output = 4000 mL

Stroke volume = End diastolic volume - End systolic volume = 90-40 mL = 50 mL

Cardiac output = Heart rate  $\times$  stroke volume

4000 mL = heart rate  $\times$  50 mL

Heart rate = 4000 mL/50 mL

Heart rate = 80 beats per minute

157. Answer (4)

**Hint:** Pisces exhibit single circulation.

**Sol.:** Fishes exhibit single circulation. Mammals and birds exhibit complete double circulation. Reptiles and amphibians exhibit incomplete double circulation.

158. Answer (4)

**Hint:** A part of hindbrain

**Sol.:** A specialised centre present in the medulla region of the brain called respiratory rhythm centre is primarily responsible for this regulation.

Normal activities of the heart are regulated intrinsically, *i.e.*, auto regulated by specialised muscles (nodal tissue), hence the heart is called myogenic. A special neural centre in the medulla oblongata can moderate the cardiac function through autonomic nervous system (ANS).

159. Answer (2)

**Hint:** Superior vena cava opens into right atrium.

**Sol.:** • Tricuspid valve opens into right ventricle.

• Bicuspid valve opens into left ventricle.

• Inferior vena cava and superior vena cava open into right atrium.

• Pulmonary veins open into left atrium.

160. Answer (3)

**Hint:** Number of ear ossicles in an ear of man.

**Sol.:** Dark reddish-brown scum is formed at the site of a cut or an injury over a period of time. It is a clot or coagulum formed mainly of a network of threads called fibrins in which dead and damaged formed elements are trapped.

Fibrins are formed by the conversion of inactive fibrinogens present in plasma by the enzyme called thrombin.

An injury or a trauma stimulates the platelets in the blood to release certain factors which activate the mechanism of coagulation.

161. Answer (3)

**Hint:** Hypertensive individual has blood pressure 140/90 mmHg or above.

**Sol.:** Hypertension is the term for blood pressure that is higher than normal (120/80). In this measurement, 120 mm Hg is the systolic or pumping pressure and 80 mm Hg is the diastolic, or resting pressure. If repeated checks of blood pressure of an individual are 140/90 or higher, it shows hypertension. High blood pressure leads to heart diseases and also affects vital organs like brain and kidney. Blood pressure is measured by sphygmomanometer.

162. Answer (3)

**Hint:** ANS constitutes sympathetic and parasympathetic nervous system.

**Sol.:** ANS constitutes sympathetic and parasympathetic nervous system. Neural signals through sympathetic nerve fibres (part of ANS) can increase the rate of heart beat, the strength of ventricular contraction and thereby the cardiac output. On the other hand, parasympathetic neural signals (another component of ANS) decrease the rate of heart beat, speed of conduction of action potentials and thereby the cardiac output.

163. Answer (4)

**Hint:** High pH can shift the oxygen dissociation curve towards left

**Sol.:** Low pO<sub>2</sub>, high pCO<sub>2</sub>, high H<sup>+</sup> concentration and high temperature are the factors responsible for dissociation of oxygen from oxyhaemoglobin. These factors cause the reduced affinity of Hb to O<sub>2</sub> and lead to right shift of sigmoidal oxygen dissociation curve.

164. Answer (4)

**Hint:** Tricuspid valve is present between the right atrium and right ventricle.

**Sol.:** Tricuspid valve is present between right atrium and ventricle. Any damage to chordae tendineae of tricuspid valve will affect the blood flow into right atrium and further to right ventricle. Bicuspid valve is present between left atrium and left ventricle.

165. Answer (1)

**Hint:** Serum = Plasma – Clotting factors.

**Sol.:** Clotting factors are responsible for blood coagulation.

Lymph, plasma and blood, all contain clotting factors and they will coagulate when left undisturbed under normal conditions. Serum on the other hand, is devoid of clotting factors, so it will not coagulate.

166. Answer (2)

**Hint:** Volume of air inspired / expired per minute.

**Sol.:** Tidal volume is the volume of air inspired or expired during a normal respiration. It is approx. 500 mL *i.e.*, a healthy man can inspire or expire approximately 6000 to 8000 mL of air per minute (minute respiratory volume) under normal conditions.

167. Answer (4)

**Hint:** Utilisation of O<sub>2</sub> by cells for metabolism is last step.

**Sol.:** Respiration involves the following steps.

- Pulmonary ventilation
- Diffusion of gases across alveolar membrane.
- Transport of gases by blood
- Diffusion of O<sub>2</sub> and CO<sub>2</sub> between blood and tissues
- Cellular respiration

168. Answer (3)

**Hint:** 70% filling of ventricles during relaxation.

**Sol.:** Blood from pulmonary veins and vena cava, fill left and right atria respectively. The buildup of pressure that results due to filling of atria, just before joint diastole and decreased pressure in ventricles during diastole, causes the AV valves to open during joint diastole and blood to flow from atria to ventricles. Nearly 70% of ventricles get filled with blood during joint diastole.

169. Answer (1)

**Hint:** The process of exhalation

**Sol.:** Relaxation of the diaphragm and the intercostal muscles returns the diaphragm and sternum to their normal positions and reduce the thoracic volume and thereby the pulmonary volume. This leads to an increase in intra-pulmonary pressure to slightly above the atmospheric pressure causing the expulsion of air from the lungs, *i.e.*, expiration.

170. Answer (4)

**Hint:** Arteries carry blood away from heart.

**Sol.:** The deoxygenated blood pumped into the pulmonary artery is passed on to the lungs from where the oxygenated blood is carried by the pulmonary veins into the left atrium. This pathway constitutes the pulmonary circulation. The oxygenated blood entering the aorta is carried by a network of arteries, arterioles and capillaries to the tissues from where the deoxygenated blood is collected by a system of venules, veins and vena cava and emptied into the right atrium. This is the systemic circulation.

171. Answer (3)

**Hint:** pCO<sub>2</sub> in deoxygenated blood = 45 mm Hg.

**Sol.:**

Respiratory Gas	Atmospheric Air	Alveoli	Blood (Deoxygenated)	Blood (Oxygenated)	Tissues
O <sub>2</sub>	159	104	40	95	40
CO <sub>2</sub>	0.3	40	45	40	45

172. Answer (1)

**Hint:** Volume that cannot be measured by spirometer

**Sol.:** **Vital Capacity (VC):** The maximum volume of air a person can breathe in after a forced expiration. or the maximum volume of air a person can breathe out after a forced inspiration. This includes ERV, TV and IRV.

**Residual Volume (RV):** Volume of air remaining in the lungs even after a forcible expiration. This averages 1100 mL to 1200 mL.

173. Answer (1)

**Hint:** Capillaries facilitate diffusion.

**Sol.:** Each artery and vein consist of three layers: an inner lining of squamous endothelium, the tunica intima, a middle layer of smooth muscle and elastic fibres, the tunica media, and an external layer of fibrous connective tissue with collagen fibres, the tunica externa.

The walls of capillaries are composed of just one cell thick layer – a squamous epithelium or endothelium. So, it forms diffusion boundaries.

144. Answer (1)

**Hint:** RBCs are absent in lymph.

**Sol.:** Exchange of nutrients, gases, *etc.*, between the blood and the cells always occur through tissue fluid (lymph). An elaborate network of vessels called the lymphatic system collects this fluid and drains it back to the major veins. Lymph is a colourless fluid containing specialised lymphocytes which are responsible for the immune responses of the body. Interstitial fluid enables intercellular communication between the cells.

175. Answer (4)

**Hint:** Haemoglobin contains 2 $\alpha$  and 2 $\beta$  chains.

**Sol.:** Haemoglobin is a red coloured iron containing pigment present in the RBCs. Each haemoglobin molecule can carry a maximum of four molecules of O<sub>2</sub>. Haemoglobin is a respiratory pigment in both vertebrates and invertebrates.

Each haemoglobin has one iron atom in each  $\alpha$  and  $\beta$  chain.

176. Answer (1)

**Hint:** Role of oxygen in regulation of respiratory rhythm is insignificant.

**Sol.:** Receptors associated with aortic arch and carotid artery can recognise changes in  $\text{CO}_2$  and  $\text{H}^+$  concentration and send necessary signals to the rhythm centre for remedial actions. The role of oxygen in the regulation of respiratory rhythm is quite insignificant.

177. Answer (2)

**Hint:** Diffusion membrane is made up of 3 major layers.

**Sol.:** The diffusion membrane is made up of 3 major layers namely, the thin squamous epithelium of alveoli, the endothelium of alveolar capillaries and the basement substance in between them. However, its total thickness is much less than a millimetre.

178. Answer (3)

**Hint:** Pulmonary ventilation is the first step in respiration.

**Sol.:** First step in respiration is breathing or pulmonary ventilation by which atmospheric air is drawn in and  $\text{CO}_2$  rich alveolar air is released out. Nearly, 70 per cent of carbon dioxide is transported as bicarbonate ( $\text{HCO}_3^-$ ) through the blood plasma.

179. Answer (1)

**Hint:** Arthropods and molluscs have open circulatory system.

**Sol.:** Open circulatory system is present in arthropods and molluscs in which blood pumped by the heart passes through large vessels into open spaces or body cavities called sinuses. Annelids and chordates have a closed circulatory system in which the blood pumped by the heart is always circulated through a closed network of blood vessels.

Butterfly – Arthropod

Humans, crocodiles – Chordates

Sponges – Poriferans (circulatory system absent)

180. Answer (3)

**Hint:** Include different levels of body organisation

**Sol.:** Mechanisms of breathing vary among different groups of animals depending mainly on their habitats and levels of organisation.

Lower invertebrates like sponges, coelenterates, flatworms, etc., exchange  $\text{O}_2$  with  $\text{CO}_2$  by simple diffusion over their entire body surface. Earthworms use moist cuticle. Likewise, complex organisms use specialised organs for respiration.

