

All India Aakash Test Series for NEET - 2026

TEST - 3 (Code-E)[Click here for Code-F Sol.](#)

Test Date : 28/12/2025

ANSWERS

1. (2)	37. (2)	73. (2)	109. (3)	145. (3)
2. (2)	38. (4)	74. (3)	110. (4)	146. (3)
3. (4)	39. (2)	75. (3)	111. (2)	147. (2)
4. (3)	40. (3)	76. (2)	112. (1)	148. (2)
5. (2)	41. (3)	77. (1)	113. (4)	149. (3)
6. (1)	42. (2)	78. (1)	114. (1)	150. (2)
7. (3)	43. (1)	79. (4)	115. (2)	151. (4)
8. (1)	44. (1)	80. (4)	116. (4)	152. (3)
9. (3)	45. (3)	81. (2)	117. (4)	153. (2)
10. (2)	46. (2)	82. (2)	118. (2)	154. (4)
11. (3)	47. (1)	83. (1)	119. (3)	155. (4)
12. (1)	48. (4)	84. (4)	120. (1)	156. (2)
13. (1)	49. (1)	85. (2)	121. (2)	157. (2)
14. (1)	50. (2)	86. (3)	122. (4)	158. (3)
15. (3)	51. (4)	87. (2)	123. (3)	159. (4)
16. (1)	52. (3)	88. (4)	124. (3)	160. (2)
17. (4)	53. (1)	89. (1)	125. (1)	161. (4)
18. (2)	54. (1)	90. (1)	126. (4)	162. (2)
19. (2)	55. (2)	91. (1)	127. (3)	163. (3)
20. (3)	56. (4)	92. (4)	128. (2)	164. (2)
21. (3)	57. (1)	93. (1)	129. (4)	165. (4)
22. (3)	58. (2)	94. (1)	130. (4)	166. (3)
23. (2)	59. (4)	95. (4)	131. (2)	167. (3)
24. (2)	60. (2)	96. (2)	132. (3)	168. (2)
25. (2)	61. (1)	97. (3)	133. (2)	169. (4)
26. (3)	62. (3)	98. (4)	134. (4)	170. (3)
27. (3)	63. (4)	99. (2)	135. (4)	171. (2)
28. (4)	64. (4)	100. (1)	136. (3)	172. (3)
29. (4)	65. (3)	101. (4)	137. (3)	173. (2)
30. (2)	66. (2)	102. (3)	138. (4)	174. (3)
31. (3)	67. (1)	103. (4)	139. (2)	175. (3)
32. (1)	68. (2)	104. (1)	140. (2)	176. (2)
33. (3)	69. (4)	105. (4)	141. (4)	177. (1)
34. (2)	70. (3)	106. (2)	142. (2)	178. (3)
35. (4)	71. (2)	107. (3)	143. (4)	179. (1)
36. (4)	72. (2)	108. (1)	144. (2)	180. (3)

HINTS & SOLUTIONS

[PHYSICS]

1. Answer (2)

Hint: No external torque is acting on the system about the axis of rotation of disc.

Sol.: $\vec{L}_{\text{initial}} = \vec{L}_{\text{final}}$

$$2 \times 20 \times 1 = \frac{1}{2} \times 20 \times 1^2 \times \omega$$

$$\omega = 4 \text{ rad/s}$$

$$e = \frac{\omega R}{20}$$

$$\Rightarrow e = \frac{4}{20} = \frac{1}{5}$$

2. Answer (2)

Hint: Force applied by the person during climbing is internal force for the system.

Sol.: $\vec{v}_{\text{cm}} = 0$

$$M\vec{V} + m\vec{v} = 0$$

$$\frac{m\Delta r_1}{\Delta t} + \frac{M\Delta r_2}{\Delta t} = 0$$

Let d_1 is the distance climbed by the man w.r.t. ground and d_2 is the distance moved by the balloon w.r.t. ground.

$$d_1 = L - d_2$$

$$md_1 - Md_2 = 0$$

$$md_1 = Md_2$$

$$m(L - d_2) = Md_2$$

$$d_2 = \frac{mL}{m + M} = \frac{50 \times 20}{(50 + 150)}$$

$$= \frac{1000}{200} = 5 \text{ m}$$

3. Answer (4)

Hint: Use energy conservation

Sol.: $mgh = \frac{1}{2}mv^2 + \frac{1}{2}I\omega^2$ and, $I = \frac{mr^2}{2}$ and $\omega = \frac{v}{r}$

$$\Rightarrow mgh = \frac{mv^2}{2} + \frac{1}{2} \times \frac{mv^2}{2}$$

$$\Rightarrow 4 \times 10 \times 3 = 2v^2 + v^2$$

$$\Rightarrow 3v^2 = 120$$

$$\Rightarrow v = \sqrt{40} = 2\sqrt{10} \text{ m/s}$$

4. Answer (3)

Hint: $g = \frac{GM}{R^2}$, $\frac{\Delta g}{g} = \frac{\Delta M}{M} - 2 \frac{\Delta R_e}{R_e}$

Sol.: $\frac{\Delta g}{g} \times 100 = \frac{\Delta M}{M} \times 100 - 2 \frac{\Delta R_e}{R_e} \times 100$

$$= 2\% - 2 \times (-1\%)$$

$$= 2 + 2 = +4\%$$

The percentage change in value of g is of approximately +4%.

5. Answer (2)

Hint: Use, $F_{\text{net}} = m \times a_{\text{COM}}$

Sol.: $a_{\text{COM}} = \frac{F_{\text{net}}}{M_{\text{total}}} = \frac{6}{6} = 1 \text{ m/s}^2$

$$\Rightarrow v_{\text{COM}} = a_{\text{COM}} \times t = 1 \times 5 = 5 \text{ m/s}$$

6. Answer (1)

Hint: $x_{\text{cm}} = \frac{m_1x_1 + m_2x_2}{m_1 + m_2}$

Sol.: Let centre O of disc be at origin.

Due to symmetry COM of remaining part will be on the x -axis.

$$m = \frac{\pi \left(\frac{R}{2}\right)^2 M}{\pi R^2} = \frac{M}{4}$$

and COM of circular hole will lie at $x = \frac{R}{2}$

For remaining part

$$x_{\text{cm}} = \frac{M \times 0 - \frac{M}{4} \left(\frac{R}{2}\right)}{M - \frac{M}{4}} = -\frac{R}{6} = -\frac{1}{2} \text{ m}$$

7. Answer (3)

Hint: Apply formula $y_{\text{cm}} = \frac{\int y dm}{\int dm}$

Sol.: $y_{\text{cm}} = \frac{\int y dm}{\int dm} = \frac{\int y \times \lambda A dy}{\int \lambda A dy}$

$$y_{cm} = \frac{\int_0^1 y \times a(1+by^2)dy}{\int_0^1 a(1+by^2)dy} = \frac{\int_0^1 (y+by^3)dy}{\int_0^1 (1+by^2)dy}$$

$$y_{cm} = \frac{\left(\frac{y^2}{2} + \frac{by^4}{4}\right)_0^1}{\left(y + \frac{by^3}{3}\right)_0^1} = \frac{\frac{1}{2} + \frac{b}{4}}{1 + \frac{b}{3}} = \frac{3(2+b)}{4(3+b)}$$

8. Answer (1)

Hint: Total energy of satellite moving in circular orbit, $E = -\frac{GMm}{2R}$

Sol.: When radius is doubled (i.e. $R \rightarrow 2R$)

$$E' = -\frac{GMm}{2 \cdot (2R)} = \frac{E}{2}$$

9. Answer (3)

Hint: $K = \frac{1}{2}I\omega^2$ and $\omega = \omega_0 + \alpha t$

Sol.: $\omega_0 = 40 \text{ rad/s}$

$$\alpha = -2 \text{ rad/s}^2$$

$$K = \frac{1}{2}I\omega^2 \Rightarrow K \propto \omega^2$$

For same kinetic energy, magnitude of ω should be same.

$$\omega = \omega_0 + \alpha t$$

$$-40 = 40 - 2 \times t$$

$$\Rightarrow t = 40 \text{ s}$$

10. Answer (2)

Hint: Use equation $Y = \frac{FL}{A\Delta L}$

Sol.: Stress = $\frac{F}{A}$, for a smaller radius, area is less so stress is higher for the same force.

$$\text{Strain} = \frac{\Delta L}{L} \text{ and } Y = \frac{\text{Stress}}{\text{Strain}}$$

$$\text{Strain} = \frac{\text{Stress}}{Y}$$

So higher stress (due to smaller area) leads to greater strain and thus greater elongation.

11. Answer (3)

Hint and Sol.:

Young's modulus depends on

(1) Nature of material

(2) Impurities

(3) Temperature

Young's modulus is independent from both stress and strain

12. Answer (1)

Hint and Sol.: $\frac{U}{V} = \frac{1}{2} \times \text{Stress} \times \text{Strain}$

$$\text{Strain} = \frac{\Delta L}{L} \Rightarrow \text{Dimensionless}$$

Reciprocal of bulk modulus is known as compressibility.

Breaking point is the point on stress-strain curve beyond which material breaks.

13. Answer (1)

Hint and Sol.: For an ideal rigid body, bulk modulus is infinite.

Modulus of rigidity is the characteristic of solid material only.

14. Answer (1)

Hint and Sol.: R.D = Density of body/Density of reference substance (water).

The weight of a plastic bag full of air is same as that of an empty plastic bag because air inside the bag displaces an equal amount of air outside and force of upthrust is equal to weight of air enclosed.

$$\rho_l V_d g_{\text{eff}} = mg_{\text{eff}}$$

$$V_d = \frac{m}{\rho_l}$$

15. Answer (3)

Hint: Use conservation of angular momentum.

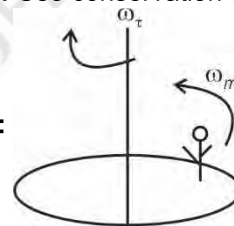

Sol.:

$$L_i = L_f$$

$$\omega_t = \frac{I_m \omega_m}{I_t}$$

$$\omega_m = \frac{v}{r} = 5 \text{ rad/s}$$

$$\omega_t = 150 \times \frac{1}{25} \times \frac{5}{3000}$$

$$= \frac{30}{3000} = \frac{1}{100} \text{ rad/s}$$

16. Answer (1)

Hint: Moment of inertia, $I = \Sigma mr^2$

Sol.: Moment of inertia does not depend on angular acceleration.

17. Answer (4)

Hint and Sol.: Escape velocity is independent of angle of projection.

18. Answer (2)

Hint: $W_{\text{ext}} = U_f - U_i$

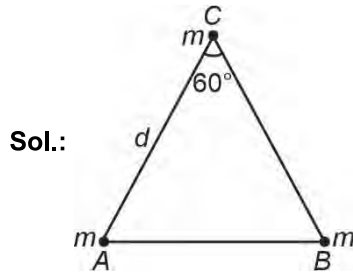

$$U_i = U_{12} + U_{23} + U_{31}$$

$$U_i = -\frac{3Gmm}{d} = -\frac{3Gm^2}{d}$$

$$U_f = -\frac{3Gm^2}{2d}$$

$$\Rightarrow WD = U_f - U_i = \frac{3Gm^2}{2d}$$

$$= \frac{3}{2}G \times \frac{4}{4}$$

$$= \frac{3}{2}GJ$$

19. Answer (2)

Hint and Sol.: Angular momentum, $L = mvr$

For a satellite close to surface of planet

$$v_0 = \sqrt{\frac{GM}{R}} = \frac{v_e}{\sqrt{2}}$$

i.e. $v_e = \sqrt{2}v_0$

20. Answer (3)

Hint: Use manometric equation

Sol.: $P_B + \rho_2 g(5 + H) - \rho_1 g5 = P_A$

$$P_A = P_B = P_{\text{atm}}$$

$$H = \left(\frac{2.5 - 0.8}{0.8}\right)5$$

$$= 10.625 \text{ cm}$$

21. Answer (3)

Hint and Sol.: The shell behaves like a point mass located at its center but only for points outside the shell. Due to absence of atmosphere on moon, atmospheric pressure is zero.

22. Answer (3)

Hint: Gravitational field $g = -\frac{\Delta V}{\Delta x}$

Sol.: $g = -\frac{\Delta V}{\Delta x} = -\frac{(-5)}{20}$

$$= \frac{1}{4} \text{ J/kg m}$$

Work done in moving a mass of 4 kg from the surface to a point 10 m above the surface.

$$W = mgh = 4 \times \frac{1}{4} \times 10 = 10 \text{ J}$$

23. Answer (2)

Hint: Use principle of conservation of angular momentum.

Sol.: $L = I\omega$

$$\because \tau_{\text{net}} = 0 \Rightarrow L = \text{constant}$$

For sphere $I = \frac{2}{5}MR^2$

$$\omega = \frac{2\pi}{T}$$

$$I_1\omega_1 = I_2\omega_2 \Rightarrow R_1^2 \cdot \frac{1}{T_1} = R_2^2 \cdot \frac{1}{T_2}$$

R = initial radius, initial time = 24 hrs

$$R^2 \times \frac{1}{24} = \left(\frac{R}{2}\right)^2 \cdot \frac{1}{T_2} \Rightarrow T_2 = 6 \text{ hrs}$$

24. Answer (2)

Hint: Apply momentum and energy conservation

Sol.: $\vec{P}_i = \vec{P}_f \Rightarrow 2 \times 10 = 10 \times v' \Rightarrow v' = 2 \text{ m/s}$

$$\frac{1}{2}mv^2 + 0 = \frac{1}{2}(M + m)v'^2 + mgh$$

On solving

$$\frac{1}{2} \times 2 \times 10^2 = \frac{1}{2} \times 10 \times 2^2 + 2 \times 10 \times h$$

$$h = 4 \text{ m}$$

25. Answer (2)

Hint: Torque of hinge force about hinge is zero.

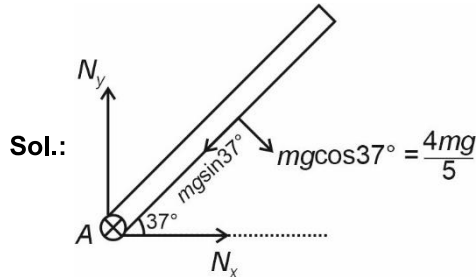

Sol.:

Taking torque about hinge, $\Sigma\tau = I\alpha$

$$\left(\frac{4mg}{5}\right)\frac{l}{2} = \frac{ml^2}{3}\alpha$$

$$\alpha = \frac{6g}{5l}$$

26. Answer (3)

Hint: Gravitational field inside earth is given by

$$g(r) = \frac{GMr}{R^3}$$

Sol.: Acceleration due to gravity at height $\frac{R}{4}$ from

$$\begin{aligned} \text{the surface of earth, } g(h) &= \frac{GM}{\left(R + \frac{R}{4}\right)^2} = \frac{GM}{\left(\frac{5R}{4}\right)^2} \\ &= \frac{16GM}{25R^2} \end{aligned}$$

$$g(h) = \frac{16}{25}g$$

Gravitational field inside earth at $r = \frac{R}{4}$

$$g' = \frac{g}{4}$$

$$\therefore g(h) = \frac{64}{25}g'$$

27. Answer (3)

Hint: Use formula $\vec{E} = -\frac{\partial V}{\partial r}\hat{r}$

Sol.: $V = -kx^3y^2$

$$\vec{E} = -\frac{\partial V}{\partial x}\hat{i} - \frac{\partial V}{\partial y}\hat{j} - \frac{\partial V}{\partial z}\hat{k}$$

$$= k \times 3x^2y^2\hat{i} + kx^3 \times (2y)\hat{j}$$

$$= 3kx^2y^2\hat{i} + 2x^3yk\hat{j}$$

$$\left(\vec{E}\right)_{(2,1,0)} = (3 \times k \times 4 \times 1)\hat{i} + (2 \times 8 \times 1)k\hat{j}$$

$$= 12k\hat{i} + 16k\hat{j}$$

28. Answer (4)

Hint and Sol.: For uniform hollow sphere, field inside the sphere is zero while potential remains constant.

$$\text{For a solid sphere } V_{\text{centre}} = \frac{3}{2}V_{\text{surface}}$$

29. Answer (4)

Hint: Excess pressure inside a drop, $\Delta P = \frac{2T}{r}$

$$\text{Sol.: } \Delta P = \frac{2T}{r}$$

$$\frac{2T}{r_1} = \frac{6 \times 2T}{r_2}$$

$$\frac{r_2}{r_1} = 6 \Rightarrow \frac{A_2}{A_1} = \left(\frac{r_2}{r_1}\right)^2 = \frac{36}{1}$$

30. Answer (2)

Hint: $P + \frac{1}{2}\rho v^2 + \rho gh = \text{constant}$

Sol.: Bernoulli's theorem is derived from conservation of energy and applies to non-viscous, incompressible and steady flow.

$$P + \frac{1}{2}\rho v^2 + \rho gh = \text{constant}$$

\Rightarrow Pressure energy per unit volume + kinetic energy per unit volume + potential energy per unit volume = constant

Fluid speed is maximum where pressure is minimum.

31. Answer (3)

Hint: A soap film on a frame has two surfaces.

Sol.: $PE = 2TA$

$$= 2 \times 40 \times 10^{-3} \times 8 \times 10^{-3}$$

$$= 640 \times 10^{-6}$$

$$= 64 \times 10^{-5} \text{ J}$$

32. Answer (1)

Hint: Surface tension force will balance the weight of the water between the plates.

Sol.: Let the length of the plate be l and h is the height rise between the plates.

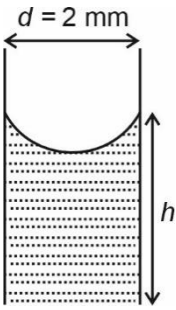

$$2Tl = \rho dlhg$$

Put all the values in cgs.

$$2 \times 22.3 = 1 \times \frac{2}{10} \times h \times 1000$$

$$h = 2.23 \text{ mm}$$

33. Answer (3)

Hint: Weight of the wire is balanced by force due to surface tension.

$$\text{Sol.: } mg = 2Tl$$

$$m \times 10 = 2 \times 6 \times 10^{-2} \times 0.4$$

$$m \times 10 = 4.8 \times 10^{-2}$$

$$m = 4.8 \times 10^{-3} \text{ kg}$$

34. Answer (2)

Hint: For isothermal condition, $PV = P_1V_1 + P_2V_2$

$$\text{Sol.: } \frac{4T}{R} \times R^3 = \frac{4T}{R_1} \times R_1^3 + \frac{4T}{R_2} \times R_2^3$$

$$\Rightarrow R^2 = R_1^2 + R_2^2$$

$$\Rightarrow R = \sqrt{R_1^2 + R_2^2}$$

$$R = \sqrt{4 + 16} = \sqrt{20} \text{ cm}$$

35. Answer (4)

Hint and Sol.: Weight of body $W = V\rho_b g$

Buoyant force in water = $0.5 V \rho_w g$

$$\rho_b = 0.5 \rho_w$$

$$\frac{V_{\text{immersed}}}{\text{Total volume}} = \frac{\rho_{\text{Body}}}{\rho_{\text{Liquid}}} = \frac{0.5}{1.5} = \frac{1}{3}$$

Percentage of volume immersed in liquid $\approx 33.33\%$

36. Answer (4)

Hint: Relation between time period and radius of orbit is given by

$$T^2 \propto R^3$$

$$\text{Sol.: } T^2 \propto R^3$$

$$T = KR^{\frac{3}{2}}$$

$$\log T = \log(K) + \frac{3}{2} \log(R)$$

$$y = mx + c$$

37. Answer (2)

Hint: $AV = \text{constant}$

$$\text{Sol.: } 8 \times 4A = 2 \times 2A + 3 \times A \times V$$

$$32A = 4A + 3AV$$

$$3V = 28$$

$$V = \frac{28}{3} \text{ m/s}$$

38. Answer (4)

Hint and Sol.: In a gas the rise in temperature increases the random motion of atoms and thus coefficient of viscosity increases.

39. Answer (2)

Hint and Sol.:

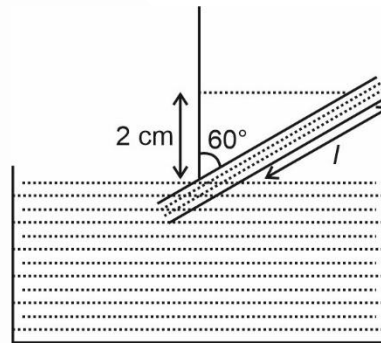

From figure, $l \cos 60^\circ = 2$

$$l \times \frac{1}{2} = 2 \Rightarrow l = 4 \text{ cm}$$

40. Answer (3)

$$\text{Hint: } V_{\text{efflux}} = \sqrt{2gh}$$

Sol.: From Bernoulli's equation

$$\frac{P_{\text{atm}}}{\rho g} + 3H = \frac{V^2}{2g} + \frac{P_{\text{atm}}}{\rho g} + H$$

$$\Rightarrow V = \sqrt{2gH \times 2} = \sqrt{4gH}$$

41. Answer (3)

Hint: Gravitational field intensity due to a point mass $I = \frac{GM}{r^2}$

$$\text{mass } I = \frac{GM}{r^2}$$

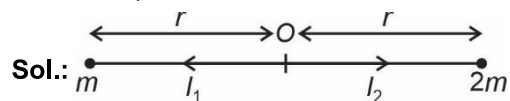

$$\text{Sol.: } m \quad \leftarrow \quad \overset{r}{\quad} \quad O \quad \overset{r}{\quad} \quad \rightarrow \quad 2m$$

$$I_{\text{net}} = I_2 - I_1$$

$$= \frac{2Gm}{r^2} - \frac{Gm}{r^2}$$

$$= \frac{Gm}{r^2}$$

42. Answer (2)

Hint: Apply Bernoulli theorem.

$$\text{Sol.: } P_1 + \frac{1}{2}\rho v_1^2 = P_2 + \frac{1}{2}\rho v_2^2$$

$$v_1 = 0, v_2 = ?$$

$$3.5 \times 10^5 = 3 \times 10^5 + \frac{1}{2} \times 10^3 \times v_2^2$$

$$\frac{0.5 \times 10^5 \times 2}{10^3} = v_2^2 \Rightarrow v_2 = 10 \text{ m/s}$$

43. Answer (1)

Hint and Sol.: Hooke's law holds good upto the proportional limit.

44. Answer (1)

Hint: Use formula $\vec{\tau} = \vec{r} \times \vec{F}$

$$\text{Sol.: } \begin{vmatrix} \hat{i} & \hat{j} & \hat{k} \\ 1 & 2 & -1 \\ -2 & 2 & 2 \end{vmatrix}$$

$$= (4+2)\hat{i} - (2-2)\hat{j} + (2+4)\hat{k}$$

$$\vec{\tau} = 6\hat{i} + 6\hat{k}$$

$$|\vec{\tau}| = 6\sqrt{2} \text{ N m}$$

45. Answer (3)

Hint: Moment of inertia of a ring about its axis is given by $I = mr^2$

$$\text{Sol.: } 2\pi r = \ell$$

$$I = \frac{M\ell^2}{4\pi^2} = \frac{\pi \times 4}{4 \times \pi^2}$$

$$I = \frac{1}{\pi} \text{ kg m}^2$$

[CHEMISTRY]

46. Answer (2)

Hint: $\Delta G^\circ = -2.303 \times RT \log K_c$

$$\text{Sol.: } K_c = \frac{[B]^2[C]}{[A]}$$

$$K_c = \frac{(0.4)^2 \times 0.2}{0.4} = 0.08$$

$$\Delta G^\circ = -2.303 \times 8.314 \times 10^{-3} \times 300 \times \log 0.08$$

$$= 6.3 \text{ kJ mol}^{-1}$$

47. Answer (1)

$$\text{Hint: } \Lambda_m = \frac{1000 \times k}{C}$$

$$\text{Sol.: } \Lambda_m = \frac{1000 \times 2.8 \times 10^{-2}}{0.2}$$

$$= 140 \text{ S cm}^2 \text{ mol}^{-1}$$

48. Answer (4)

Hint: 1 Faraday charge will deposit 1 g equivalent of copper at cathode.

Sol.:

$$\text{Number of Faradays passed} = \frac{1.158 \times 60 \times 60}{96500}$$

$$\text{Mass of copper deposited} = \frac{1.158 \times 60 \times 60}{96500} \times \frac{63.5}{2}$$

$$= 1.37 \text{ g}$$

49. Answer (1)

Hint: Dry cell is also known as Leclanche cell.

Sol.:

- In Leclanche cell (Dry cell), zinc container acts as anode while carbon (graphite) rod surrounded by powdered manganese dioxide and carbon acts as cathode.

- In the primary batteries, the reaction occurs only once and after use over a period of time battery becomes dead and cannot be reused again.

50. Answer (2)

Hint: In a disproportionation reaction an element in one oxidation state is simultaneously oxidised and reduced.

Sol.: Given below are the disproportionation reaction.

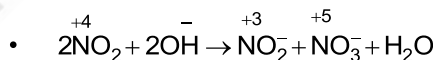
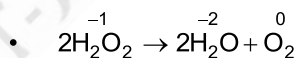
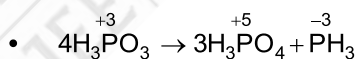

51. Answer (4)

Hint: For reversible isothermal process, the work done

$$w = -2.303nRT \log \frac{V_f}{V_i}$$

$$\text{Sol.: } w = -2.303 \times 2 \times 8.314 \times 300 \log \frac{20}{5}$$

$$w = -6.89 \text{ kJ}$$

$$\Delta H = nC_p \Delta T$$

Since the process is isothermal $\Delta H = 0$

52. Answer (3)

Hint: H_2SO_5 contains peroxide linkage.

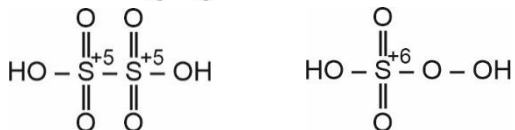
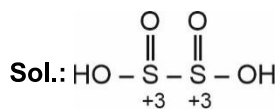

53. Answer (1)

Hint: A metal in a compound can be displaced by another metal in the uncombined state. This is called metal displacement reaction.

Sol.:

- Combination reaction:

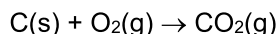

- Decomposition reaction:

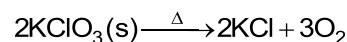

- Metal displacement reaction

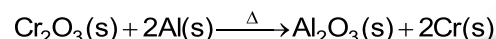

- Non-metal displacement reaction

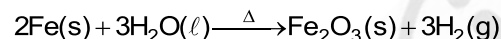

54. Answer (1)

Hint: Down the group, acidity of hydrides (HA) increases. (A is a chalcogen)

Sol.: Down the group, size of the element (A) increases as a result H-A bond strength decreases and so the acid strength increases.

55. Answer (2)

Hint: The salts which undergo anionic hydrolysis makes the solution alkaline.

Sol.: Salts of weak acid and strong base undergo anionic hydrolysis, making solution alkaline in nature.

Same is true for sodium phenoxide and sodium benzoate

56. Answer (4)

Hint: Solubility of AgBr will decrease in the presence of common ion derived from sodium bromide.

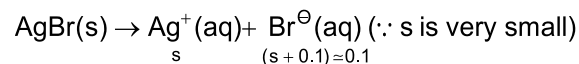
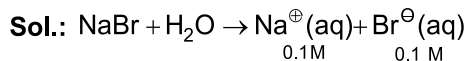

$$s \times 0.1 = 5 \times 10^{-13}$$

$$s = \frac{5 \times 10^{-13}}{0.1} = 5 \times 10^{-12}$$

$$s = 5 \times 10^{-12} \text{ M}$$

57. Answer (1)

Hint: The salt formed in the reaction will go anionic hydrolysis.

$$\text{pH} = 7 + \frac{1}{2}(\text{pK}_a + \log c)$$

Sol.:

Initial	40 × 0.1 = 4 mmol	10 × 0.4 = 4 mmol	-	-
Final	0	0	4 mmol	

$$\text{Concentration of CH}_3\text{COONa} = \frac{4}{50} = 0.08$$

$$\text{pH} = 7 + \frac{1}{2}(\text{pK}_a + \log c)$$

$$= 7 + \frac{1}{2}(4.76 + \log 0.08)$$

$$= 7 + \frac{1}{2}(4.76 - 1.1)$$

$$\text{pH} = 8.83$$

58. Answer (2)

Hint: Iodine gives intense blue colour with starch

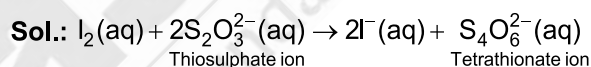

59. Answer (4)

Hint: SO_3^{2-} is oxidised to sulphate while MnO_4^- is reduced to Mn^{2+} .

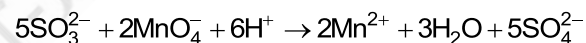
Sol.:

60. Answer (2)

Hint: Internal energy is the state function, hence

$$\Delta U_{\text{ABC}} = -\Delta U_{\text{CBA}}$$

Sol.: For the process, A → B

$$\Delta U_{\text{AB}} = q_{\text{AB}} + w_{\text{AB}}$$

$$\Delta U_{\text{AB}} = 4 - 8 = -4 \text{ kJ mol}^{-1}$$

For the process B → C

$$\Delta U_{\text{BC}} = -7 \text{ kJ mol}^{-1}$$

$$\Delta U_{\text{ABC}} = \Delta U_{\text{AB}} + \Delta U_{\text{BC}} = -4 - 7 = -11 \text{ kJ mol}^{-1}$$

For the process, A → B → C

$$\Delta U_{\text{CBA}} = -\Delta U_{\text{ABC}} = \Delta U_{\text{CA}} = 11 \text{ kJ mol}^{-1}$$

For the process C → A

$$\Delta U_{\text{CA}} = q_{\text{CA}} + w_{\text{CA}}$$

$$q_{\text{CA}} = 11 - 2 = 9 \text{ kJ mol}^{-1}$$

61. Answer (1)

$$\text{Hint: } \Delta_r G^\circ = -nFE^\circ_{\text{cell}}$$

$$\text{Sol.: } E^\circ_{\text{cell}} = E^\circ_{\text{R}} - E^\circ_{\text{L}}$$

$$= E^\circ_{\text{Cu}^{2+}/\text{Cu}} - E^\circ_{\text{Al}^{3+}/\text{Al}} = 0.34 + 1.66 = 2.0 \text{ V}$$

For the given reaction, $n = 6$

$$\Delta_r G^\circ = -nFE^\circ_{\text{cell}}$$

$$= -6 \times 96500 \times 2$$

$$= -1158 \text{ kJ mol}^{-1}$$

62. Answer (3)

Hint: Having same charge, the smaller cations are more solvated leading to decreased ionic mobility and decreased molar conductivity.

Sol.: OH^- has exceptionally high value of molar conductivity in water at 298 K.

Mg^{2+} is smaller in size than Ca^{2+} hence Mg^{2+} is more solvated and its molar conductivity is lesser than Ca^{2+} ions in water at 298 K.

63. Answer (4)

Hint: Conductivity of copper ($5.9 \times 10^3 \text{ S m}^{-1}$) is higher than sodium ($2.1 \times 10^3 \text{ S m}^{-1}$) at 298.15 K

Sol.: Conductivity always decreases with decrease in concentration both, for weak and strong electrolytes.

64. Answer (4)

Hint: More is the disorderness, more is the entropy

Sol.: In conversion of ice to water, the randomness of molecules increases leading to a positive value of ΔS .

During phase change, at given pressure and temperature, the solid-liquid system practically remains at equilibrium and $\Delta G = 0$

65. Answer (3)

Hint: Ethene molecule breaks as

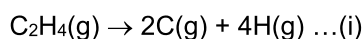

Hess's law of constant heat summation is applied.

Sol.:

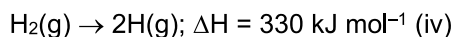
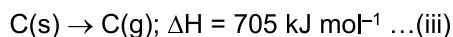
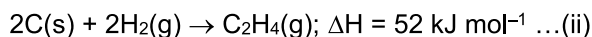

$2 \times (\text{iii}) + 2(\text{iv}) - (\text{ii})$ will give equation (i)

$$\Delta H \text{ for (i)} = 2 \times 705 + 2 \times 330 - 52$$

$$= 1410 + 660 - 52$$

$$= 2018 \text{ kJ mol}^{-1}$$

Equation (i) involves breaking of 4 C – H bonds and 1 C = C bond

ΔH for eq. (i) = 4 × bond energy of C – H + bond energy of C = C bond

$$\text{Bond energy of C = C bond} = 2018 - 4 \times 350$$

$$= 2018 - 1400$$

$$= 618 \text{ kJ mol}^{-1}$$

66. Answer (2)

Hint: NaOH is the limiting reagent.

Sol.: 1 equivalent of NaOH on reaction with 1 equivalent of H_2SO_4 will release 57.1 kJ of energy.

$$\text{Number of milliequivalents of NaOH} = 400 \times 0.4 = 160$$

$$\text{Number of milliequivalents of H}_2\text{SO}_4 = 300 \times 0.4 \times 2 = 240$$

NaOH is limiting

$$\text{Heat released on neutralisation} = 160 \times 10^{-3} \times 57.1$$

$$= 9.1 \text{ kJ}$$

67. Answer (1)

Hint: E°_{cell} is intensive property while ΔG° is extensive property.

Sol.:

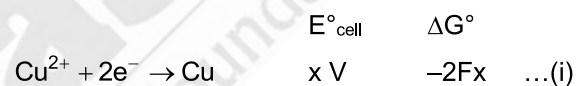

(i) – (ii) will give



$$-zF = Fy - 2Fx$$

$$z = 2x - y$$

68. Answer (2)

Hint: Sum of oxidation number of elements in a compound is zero.

Sol.: For $\text{X}_2(\text{YZ}_2)_2$, sum of oxidation number is zero.

69. Answer (4)

Hint: Higher is the value of reduction potential of metal cation, lower is the reducing power of the metal.

Sol.: Reduction potential of Mg^{2+}/Mg is most negative hence is easier to oxidise Mg and it is the best reducing agent in the given options.

Reduction potential of Cu^{2+}/Cu couple is maximum and positive hence it is difficult so oxidise copper. Copper is not a good reducing agent.

70. Answer (3)

Hint: Lewis acids are electron deficient species.**Sol.:** Conjugate base is obtained by removing one proton from the given species.Equilibrium constant (K_w) depends on temperature.

71. Answer (2)

Hint: $\text{pOH} = 14 - 10 = 4$ **Sol.:** $\text{M}(\text{OH})_2 \rightleftharpoons \text{M}^{2+} + 2\text{OH}^-$
{s is the solubility of $\text{M}(\text{OH})_2$ }

$$\text{pOH} = 4$$

$$[\text{OH}^-] = 10^{-4}$$

$$2s = 10^{-4}$$

$$s = \frac{1}{2} \times 10^{-4}$$

$$K_{\text{sp}} \text{ of } \text{M}(\text{OH})_2 = [\text{M}^{2+}] [\text{OH}^-]^2$$

$$= s (2s)^2$$

$$= \frac{1}{2} \times 10^{-4} \times (10^{-4})^2$$

$$K_{\text{sp}} = \frac{1}{2} \times 10^{-12} = 5 \times 10^{-13}$$

72. Answer (2)

Hint: A catalyst increases the rate of forward and reverse reactions that pass through the same transition state and does not affect the equilibrium.**Sol.:** Since a catalyst does not affect the equilibrium hence it does not affect equilibrium composition of reaction mixture.

73. Answer (2)

Hint: $\Delta H = \Delta U + \Delta n_g RT$ and $\Delta G = \Delta H - T\Delta S$ **Sol.:** $\Delta H = 12 + 3 \times 8.314 \times 300 \times 10^{-3}$

$$\Delta H = 12 + 7.48 = 19.48 \text{ kJ}$$

$$\Delta G = \Delta H - T\Delta S$$

$$= 19.48 - 300 \times 80 \times 10^{-3}$$

$$= (19.48 - 24) \text{ kJ}$$

$$= -4.52 \text{ kJ}$$

74. Answer (3)

Hint: Mixture of RNH_2 and RNH_3^+ in aqueous medium will act as basic buffer.

$$\text{pOH} = \text{p}K_b + \log \frac{[\text{Salt}]}{[\text{Base}]}$$

Sol.:

	RNH_2	+	HCl	\rightarrow	$\text{RNH}_3^+\text{Cl}^-$
Initial	100×0.2		160×0.1		-
	$= 20 \text{ mmol}$		$= 16 \text{ mmol}$		
Final	4 mmol		0		16 mmol

$$\text{pOH} = (4 - \log 4) + \log \frac{16}{4}$$

$$\text{pOH} = 3.4 + 0.6$$

$$\text{pOH} = 4.0$$

$$\text{pH} = 14 - 4 = 10$$

75. Answer (3)

Hint: During phase change from solid to gaseous state, the entropy increases.**Sol.:** On decomposition, the number of particles increases hence entropy increases.

76. Answer (2)

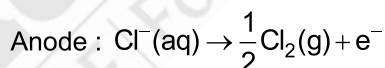
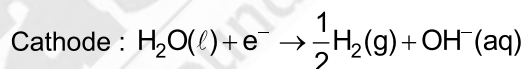
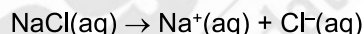
Hint: Reduction potential of Na^+ is very low (-2.71 V)**Sol.:** Reduction potential of $\text{H}^+(\text{aq})$ is zero, hence H_2 gas is liberated at cathode.

Net reaction :

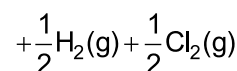
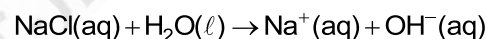

77. Answer (1)

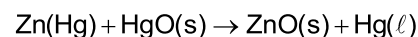
Hint: For mercury cell, overall reaction is**Sol.:** The cell potential of mercury cell is approximately 1.35 V and remains constant during its life as the overall reaction does not involve any ion in solution whose concentration can change during its life

78. Answer (1)

$$\text{Hint: } R = \frac{\rho \ell}{A} \quad \dots(\text{i})$$

$$\kappa = \frac{1}{\rho} \quad \dots(\text{ii})$$

Sol.: $A = \pi r^2 = 3.14 \times 0.4 \times 0.4 \text{ cm}^2$

From (i) we can write

$$\rho = \frac{RA}{\ell} = \frac{5 \times 10^3 \times 3.14 \times 0.4 \times 0.4}{40}$$

$$\rho = 62.8 \text{ ohm cm}$$

$$\kappa = \frac{1}{\rho} = \frac{1}{62.8} = 1.6 \times 10^{-2} \text{ S cm}^{-1}$$

79. Answer (4)

Hint: For a chemical reaction at equilibrium, Gibbs energy change (ΔG) of the reaction is zero.

Sol.:

- At equilibrium, $\Delta G^\circ = -RT \ln K$

- For spontaneous process;

$$\Delta S_{\text{total}} = \Delta S_{\text{system}} + \Delta S_{\text{surr}} > 0$$

80. Answer (4)

Hint: $\Delta H = \Delta U + \Delta n_g RT$

Δn_g = The number of moles of gaseous products minus the number of moles of gaseous reactants.

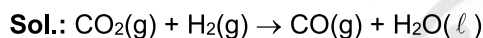

$$\Delta n_g = 1 - 2 = -1$$

$$\Delta H = \Delta U - RT$$

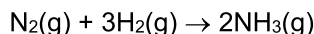

$$\Delta n_g = 2 - 4 = -2$$

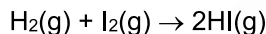

$$\Delta n_g = 2 - 2 = 0$$

$$\Delta H = \Delta U$$

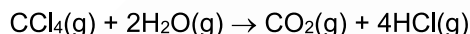

$$\Delta n_g = 5 - 3 = 2$$

$$\Delta H = \Delta U + 2RT$$

81. Answer (2)

Hint: $2\Lambda_m^\circ(\text{NH}_4\text{OH}) = 2\Lambda_m^\circ(\text{NH}_4\text{Cl}) +$

$$\Lambda_m^\circ\{\text{Ba}(\text{OH})_2\} - \Lambda_m^\circ(\text{BaCl}_2)$$

Sol.: $2\Lambda_m^\circ(\text{NH}_4\text{OH}) = 2y + x - z$

$$\Lambda_m^\circ(\text{NH}_4\text{OH}) = y + \frac{x}{2} - \frac{z}{2} \text{ (S cm}^2 \text{ mol}^{-1}\text{)}$$

82. Answer (2)

Hint and Sol.: In the most stable state of aggregation of an element, the enthalpy of formation is considered to be zero.

83. Answer (1)

Hint: Degree of dissociation (α) = $\frac{\Lambda_m}{\Lambda_m^\circ}$

Sol.: $\alpha = \frac{12}{400} = 0.03$

For weak acid, $K = C\alpha^2$

$$K = 0.05 \times (0.03)^2$$

$$K = 4.5 \times 10^{-5}$$

84. Answer (4)

Hint: For sparingly soluble salt M_xX_y if $s \text{ mol L}^{-1}$ is

the solubility then $s = \left(\frac{K_{\text{sp}}}{x^x \cdot y^y} \right)^{\frac{1}{x+y}}$

Sol.:

- For compound AB

$$s^2 = 1 \times 10^{-14}$$

$$s = 10^{-7} \text{ mol L}^{-1}$$

- For compound X_2Y

$$4s^3 = 4 \times 10^{-24}$$

$$s = 10^{-8} \text{ mol L}^{-1}$$

- For compound P_2Q_3

$$108s^5 = 1.08 \times 10^{-28}$$

$$108s^5 = 108 \times 10^{-30}$$

$$s = 10^{-6} \text{ mol L}^{-1}$$

85. Answer (2)

Hint: $\text{N}_2 + 3\text{H}_2 \rightleftharpoons 2\text{NH}_3$, K_2

hence for $2\text{NH}_3 \rightleftharpoons \text{N}_2 + 3\text{H}_2$ the equilibrium

constant will be $\frac{1}{K_2}$

Sol.:

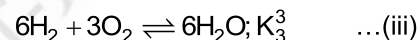
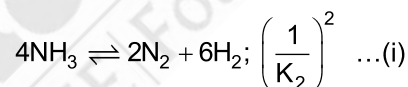

Adding equations (i), (ii) and (iii) we get,

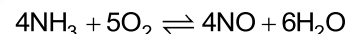

$$K = \frac{K_1^2 K_3^3}{K_2^2}$$

86. Answer (3)

Hint: As the container is insulated the process is adiabatic hence $q = 0$

Sol.: Work done (w) = $-P(\Delta V)$

$$= -4 (6.8 - 4.2)$$

$$= -10.4 \text{ L atm}$$

From first law we know

$$\Delta U = q + w$$

$$\Delta U = 0 - 10.4$$

$$\Delta U = -10.4 \times 101.3$$

$$\Delta U = -1053.5 \text{ J}$$

87. Answer (2)

Hint: $C_3H_8 + 5O_2 \rightarrow 3CO_2 + 4H_2O$

$$\Delta_r H^\circ = \sum a_i \Delta_f H^\circ(\text{products}) - \sum b_i \Delta_f H^\circ(\text{reactant})$$

$$\text{Sol.: } \Delta_r H^\circ = 3 \times (-394) + 4 \times (-286) - (-104)$$

$$= -1182 - 1144 + 104$$

$$\Delta_r H^\circ = -2222 \text{ kJ mol}^{-1}$$

88. Answer (4)

Hint: pH of acidic buffer = $pK_a + \log \frac{[\text{Salt}]}{[\text{Acid}]}$

pH of salt of strong acid and weak base

$$= 7 - \frac{1}{2}(pK_b + \log c)$$

Sol.:

(a) mmol of HCl = $100 \times 0.01 = 1$

mmol of NaOH = $100 \times 0.008 = 0.8$

$$[H^+] = \frac{1-0.8}{200} = 1 \times 10^{-3}$$

pH = 3

(b) $K_a = C\alpha^2$

$$\alpha = \sqrt{\frac{K_a}{C}} = \sqrt{\frac{1.8 \times 10^{-4}}{0.2}} = 3 \times 10^{-2}$$

$$[H^+] = C\alpha = 0.2 \times 3 \times 10^{-2} = 6 \times 10^{-3}$$

pH = $3 - \log 6 = 3 - [\log 2 + \log 3]$

pH = $3 - (0.3 + 0.477)$

pH = 2.22

(c) pH = $7 - \frac{1}{2}(4.75 + \log 0.4)$

pH = $7 - 2.175 = 4.83$

(d)

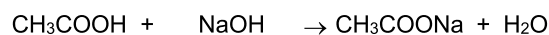

Initial	200×0.2	200×0.04	-	0
	= 40 mmol	= 8 mmol		

Final	32 mmol	0	8 mmol	
-------	---------	---	--------	--

$$pH = 4.76 + \log \frac{8}{32}$$

$$= 4.76 - 0.6 = 4.16$$

89. Answer (1)

Hint: For strong electrolytes, Λ_m increases slowly with dilution and can be represented by the equation:

$$\Lambda_m = \Lambda_m^\circ - AC^{\frac{1}{2}}$$

Sol.: NaCl, CaCl₂ and MgSO₄ are 1-1, 2-1 and 2-2 electrolytes respectively.

90. Answer (1)

Hint: $2H^+(aq) + 2e^- \rightarrow H_2(g)$

$$E_{H^+/H_2} = E_{H^+/H_2}^\circ - \frac{0.0591}{2} \log \frac{p_{H_2}}{[H^+]^2}$$

$$\text{Sol.: } E_{H^+/H_2} = 0 - \frac{0.0591}{2} \log \frac{1}{(10^{-5})^2}$$

$$= -\frac{0.0591}{2} \log 10^{10}$$

$$= -\frac{0.0591}{2} \times 10 = -0.296$$

[BOTANY]

91. Answer (1)

Hint: Cells of endodermis are rich in starch grains and hence it is called starch sheath.**Sol.:** Dicot stem has starch sheath. Endodermis is absent in monocot stem.

92. Answer (4)

Hint: In roots, pericycle forms lateral roots.**Sol.:** In both dicot and monocot root, pericycle is made up of living parenchyma cells.

93. Answer (1)

Hint: Under water stress, bulliform cells become flaccid.**Sol.:** In flaccid condition, bulliform cells curl the leaf inward.

94. Answer (1)

Hint: Isobilateral leaves are found in monocots.**Sol.:** Isobilateral leaves have equal distribution of stomata on both the surfaces. They have bulliform cells and conjoint vascular bundles.

95. Answer (4)

Hint: Companion cells are found in the phloem.**Sol.:** Companion cell is a part of vascular tissue system.

96. Answer (2)

Hint: Conjunctive tissue is found in roots.**Sol.:** Conjunctive tissue is found between xylem and phloem in roots.

97. Answer (3)
Hint: Epidermal hairs are found in both roots and shoots.
Sol.: Roots have radial vascular bundles and these are not surrounded by bundle sheath cells.
98. Answer (4)
Hint: All tissues on the innerside of the endodermis constitute stele.
Sol.: Stele includes pericycle, pith and vascular bundles.
99. Answer (2)
Hint: This is T.S. of a monocot stem.
Sol.: Here,
 A – Epidermis – It can have cuticle and trichomes.
 B – Hypodermis – It is sclerenchymatous in monocot stem but absent in roots.
 C – Vascular bundles – They have water containing cavities.
 D – Xylem – Stem has endarch protoxylem.
100. Answer (1)
Hint: Collenchyma is referred as living mechanical tissue.
Sol.: Both collenchyma and sclerenchyma are mechanical tissues.
101. Answer (4)
Hint: Trichomes are not found in roots.
Sol.: Trichomes cannot help in absorption of water rather this process is done by root hairs.
102. Answer (3)
Hint: Innermost layer of cortex is endodermis.
Sol.: Pericycle forms semi-lunar patches of sclerenchyma in dicot stem.
103. Answer (4)
Hint: Casparian strips are found on endodermal cells of roots.
Sol.: Casparian strips are suberin depositions on radial and tangential walls of barrel shaped endodermal cells.
104. Answer (1)
Hint: Pith is absent in leaves.
Sol.: Well developed pith is found in monocot roots and dicot stems.
105. Answer (4)
Sol.: Mesophyll cells are not included in stomatal apparatus.
106. Answer (2)
Hint: Dicot leaves and monocot stems both have conjoint and closed vascular bundles.
Sol.: Both of them have vascular bundles of different sizes and they lack cambium. Monocot stem has parenchymatous and sclerenchymatous cells in ground tissue while in leaves, mesophyll (parenchymatous cells) constitutes ground tissue.
107. Answer (3)
Hint: This is a dead tissue.
Sol.: Sclereids are found in fruit wall of nuts.
108. Answer (1)
Hint: Epidermal cells are usually single layered.
Sol.: Epidermal cells are parenchymatous cells having large nucleus and small amount of cytoplasm. Root hairs are unicellular.
109. Answer (3)
Hint: Wall of guard cells which is towards the pore is thick.
Sol.: Inner wall of guard cells is thick while outer wall is thin.
110. Answer (4)
Hint: Hypodermis is a multi-layered structure found in stem.
Sol.: Hypodermis is absent in roots.
111. Answer (2)
Hint: Monocot roots have polyarch xylem.
Sol.: Dicot roots have 2-4 xylem and phloem patches.
112. Answer (1)
Hint: Dicot leaves are dorsiventral leaves.
Sol.: In dicot leaves, abaxial surface bears more stomata than adaxial surface. Spongy mesophyll has air cavities. Both upper and lower surfaces have cuticle.
113. Answer (4)
Hint: Bast fibres are sclerenchymatous in nature.
Sol.: Bast fibres are made up of dead cells.
114. Answer (1)
Hint: These are thin-walled cells.
Sol.: Monocots generally lack phloem parenchyma.
115. Answer (2)
Hint: Red algae reproduce by non-motile spores and gametes.
Sol.: Both red and brown algae are found in marine water. Both have chlorophyll a and produce complex carbohydrates. Brown algae produce biflagellate zoospores but red algae do not.

116. Answer (4)
Hint: Frond is mostly seen in the members of brown algae.
Sol.: *Dictyota*, *Laminaria* and *Porphyra* have frond. *Ulothrix* lacks frond.
117. Answer (4)
Hint: Red algae are mostly found in warmer area.
Sol.: Majority of red algae are marine with greater concentration found in warmer area.
118. Answer (2)
Hint: Carrageen is found in red algae.
Sol.: Carrageen – *Gracilaria*
 Filamentous form – *Ectocarpus*
 Algin – *Sargassum*
 Body contains main axis with branches – *Polysiphonia*.
119. Answer (3)
Hint: Structures of gametophytic stage contain haploid set of chromosomes.
Sol.: Antherozoids, rhizoids, protonema – Gametophytic (n)
 Capsule, seta – Sporophytic (2n)
120. Answer (1)
Hint: In algae and bryophytes, main plant body is gametophytic.
Sol.: *Salvinia*, being pteridophyte has sporophytic main body.
121. Answer (2)
Hint: Protonema is first stage of gametophytic generation.
Sol.: Protonema is green structure that arises from spore.
122. Answer (4)
Hint: Prothallus is a gametophytic structure.
Sol.: Prothallus is haploid.
123. Answer (3)
Hint: *Selaginella* being a pteridophyte has sporophytic main plant body.
Sol.: Meiosis in spore mother cell (b)
 → Formation of micro and megaspores (e)
 → Formation of female gametophyte (d)
 → Male gamete swim and reaches to archegonia (c)
 → Zygote forms embryo (a)
124. Answer (3)
Hint: *Eudorina* shows anisogamy.
Sol.: *Pinus*, *Polytrichum* and *Pteris* has archegonia as they show oogamy.
125. Answer (1)
Hint: Gametophytes are haploid.
Sol.: Gametophytes are dependent structures in gymnosperms.
126. Answer (4)
Hint: Some pteridophytes are homosporous.
Sol.: *Dryopteris* is homosporous. Rest all are heterosporous.
127. Answer (3)
Hint: Each female gametophyte of gymnosperm has 2 or more archegonia.
Sol.: During megasporogenesis, one megaspore mother cell undergoes meiosis to form four megaspores out of which only one undergoes development to form female gametophyte.
128. Answer (2)
Hint: In *Cycas*, megasporophylls do not aggregate compactly.
Sol.: *Cycas* lacks female cones.
129. Answer (4)
Hint: Red algae shows complex post-fertilisation events.
Sol.: *Fucus* being brown alga lacks complex post-fertilisation events.
130. Answer (4)
Hint: Bryophytes are of little economic but great ecological importance.
Sol.: Prevention of soil erosion is an ecological importance of bryophytes.
131. Answer (2)
Hint: *Cycas* and *Marchantia* are dioecious.
Sol.: In *Cycas* and *Marchantia*, male and female sex organs are produced on separate plant bodies.
132. Answer (3)
Hint: Pteridophytes are first tracheophytes.
Sol.: Pteridophytes lack pollen grains. These are found in narrow geographical regions. Bryophytes are first embryophytes.
133. Answer (2)
Hint: Conifers have needle like leaves.
Sol.: Needle like leaves have reduced surface area.
134. Answer (4)
Sol.: *Lycopodium* is included in class Lycopsidea.
135. Answer (4)
Hint: Bryophytes do not have strobili.
Sol.: *Polytrichum* lacks strobili.

[ZOOLOGY]

136. Answer (3)

Hint: Exclude the part of midbrain and hindbrain**Sol.:** The forebrain of humans consists of cerebrum, thalamus and hypothalamus. Midbrain, pons and medulla oblongata together make up the brain stem. Cerebellum is a part of hindbrain.

Cerebral aqueduct is a canal that passes through the midbrain.

137. Answer (3)

Hint: Possesses neurosecretory cells**Sol.:** Hypothalamus lies at the base of the thalamus. Limbic system along with the hypothalamus is involved in the regulation of sexual behaviour. Corpus callosum is a tract of nerve fibres that connects two cerebral hemispheres. Pons and cerebellum are parts of the hindbrain.

138. Answer (4)

Hint: Most hind part of hindbrain**Sol.:** The inner parts of cerebral hemispheres and a group of associated deep structures like amygdala, hippocampus, etc. form a complex structure called the limbic system. Medulla oblongata is not the structural component of limbic system.

139. Answer (2)

Hint: Regulated by hypothalamus**Sol.:** The hypothalamus contains centres which controls urge for eating and drinking. The medulla oblongata contains centres which control respiration, cardiovascular reflexes and gastric secretions.

140. Answer (2)

Hint: Dorsally placed in human body**Sol.:** In humans, the skull region articulates with the superior region of the vertebral column with the help of two occipital condyles.

141. Answer (4)

Hint: Part of appendicular skeleton**Sol.:** Sacrum and coccyx are fused vertebral bones. Coxal bones make up the pelvic girdle. Each coxal bone is formed by the fusion of three bones – ilium, ischium and pubis. Each forelimb possess 8 carpals. Carpals are the wrist bones.

142. Answer (2)

Hint: Identify the option with longest bone**Sol.:** The bones of forelimbs are humerus, radius, ulna, carpals, metacarpals and phalanges.

143. Answer 4)

Hint: Joints act as fulcrum.**Sol.:** Joints are essential for all the types of movements involving the bony parts of the body. Locomotory movements are no exception to this.

144. Answer (2)

Hint: Also helps in transformation of host cells.**Sol.:** The increased levels of Ca^{++} leads to the binding of calcium with a subunit of troponin on actin filament and thereby remove the masking of active sites for myosin.

145. Answer (3)

Hint: Thin filament**Sol.:** During muscle contraction, actin filaments slide over the myosin filament which results in shortening of muscle. Myosin is thick filament and is polymer of meromyosin.

Collagen fibres are proteinaceous fibres found in connective tissues.

146. Answer (3)

Hint: Allows passage of small amounts of urea**Sol.:** The renal tubule begins with a double-walled cup-like structure called Bowman's capsule. The tubule further continues to form a highly coiled network *i.e.*, PCT. A hairpin shaped loop of Henle is the next part which has a descending and an ascending limb. The ascending limb continues as another highly coiled region called DCT. The DCTs of many nephrons open into a straight tube called collecting duct.

147. Answer (2)

Hint: Cortical nephrons are more in number.**Sol.:** Cortical nephrons are more in number in comparison to juxtamedullary nephrons. Cortical nephrons have very short loop of Henle while juxtamedullary nephrons have very long loop of Henle. Peritubular capillary network is present in both cortical and juxtamedullary nephrons.

148. Answer (2)

Hint: Ammonia is the most toxic nitrogenous waste.**Sol.:** Terrestrial adaptation necessitated the production of lesser toxic nitrogenous wastes like urea and uric acid for conservation of water. Ammonia is the most toxic form and requires large amount of water for its elimination.

149. Answer (3)

Hint: Prawn has green glands.

Sol.: Protonephridia/flame cells are the excretory structures in rotifers, flatworms, some annelids and the cephalochordates – *Amphioxus*.

Antennal glands or green glands perform the excretory function in crustaceans like prawns.

150. Answer (2)

Hint: Exclude the features of skeletal muscle fibres

Sol.: Smooth muscle is present in GI tract. Smooth muscle fibres are unstriated, unbranched, fusiform, uninucleated and involuntary. They also possess gap junctions. Skeletal muscle fibres are syncytial and are voluntary in nature.

151. Answer (4)

Hint: Choose the joint between flat skull bones.

Sol.: Gliding joint is present between carpals while saddle joint is present between carpal and metacarpal of thumb. These joints are synovial joints. Pivot joint is present between atlas and axis and it is also a synovial joint. Cartilaginous joint is present between adjacent vertebrae in the vertebral column except between atlas and axis. Flat skull bones fuse end-to-end with the help of dense fibrous connective tissue in the form of sutures, to form cranium.

152. Answer (3)

Hint: Both have the protein that stores O₂ in the muscles

Sol.: Both white and red muscle fibres have myoglobin but red muscle fibres have abundance of it. Red muscle fibres are rich in mitochondria while white muscle fibres have less mitochondria. White muscle fibres are rich in sarcoplasmic reticulum. Red muscle fibres undergo aerobic process for energy production while white muscle fibres depend on anaerobic process.

153. Answer (2)

Hint: Neuromuscular junction is affected in Myasthenia gravis.

Sol.: Myasthenia gravis – Autoimmune disorder affecting neuromuscular junction.

Muscular dystrophy – Progressive degeneration of skeletal muscles mostly due to genetic disorder.

154. Answer (4)

Hint: Each limb has 30 bones.

Sol.: Tarsals in both hindlimbs – 14

Carpals in both forelimbs – 16

Phalanges in both forelimbs and both hindlimbs – 56

Total number of bones in both hindlimbs – 60

155. Answer (4)

Hint: Both actin and myosin present in this portion.

Sol.: When skeletal muscle fibres are contracted maximally, the size of sarcomere and isotropic band gets reduced while the size of anisotropic band remains the same.

156. Answer (2)

Hint: Neurotransmitters are released here

Sol.: At a chemical synapse, the membranes of the pre- and post-synaptic neurons are separated by a fluid-filled space called synaptic cleft. Receptors are present on post-synaptic membrane.

157. Answer (2)

Hint: Equal to the number of digits in our right hand.

Sol.: The brain is the central information processing organ of our body and acts as the 'command and control system'. It controls the voluntary movements, balance of the body, functioning of vital involuntary organs, thermoregulation, circadian rhythms of our body.

158. Answer (3)

Hint: Podocytes

Sol.: The epithelial cells of Bowman's capsule called podocytes are arranged in an intricate manner so as to leave some minute spaces called filtration slits or slit pores. Basement substance is an acellular layer.

159. Answer (4)

Hint: True for PCT

Sol.: The PCT of renal tubule is lined by simple cuboidal brush border epithelium which increases the surface area for reabsorption. Nearly all of the essential nutrients, 70-80 per cent of the electrolytes and water are reabsorbed by this segment.

160. Answer (2)

Hint: Selective secretion of K⁺ and H⁺ occurs here

Sol.: The collecting duct allows passage of small amounts of urea into the medullary interstitium to keep up the osmolarity. Descending limb of loop of Henle is almost impermeable to electrolytes and ascending limb is impermeable to water.

161. Answer (4)

Hint: Aldosterone causes Na⁺ reabsorption.

Sol.: Angiotensin II, being a powerful vasoconstrictor, increases the glomerular blood pressure. It also acts on adrenal cortex to release aldosterone. Aldosterone causes reabsorption of Na⁺ and water from the DCT.

162. Answer (2)

Hint: Involves flagellar movement

Sol.: Flagellar movement helps in the swimming of human spermatozoa. Passage of ova through female reproductive tract, movement of mucus in specific direction in human respiratory tract and movement of food through cytopharynx in *Paramecium* are facilitated by ciliary movement.

163. Answer (3)

Hint: Macrophages perform amoeboid movement.

Sol.: Muscles have been classified using different criteria namely location, appearance and nature of regulation of their activities. Based on their location, three types of muscles are identified:

- (i) Skeletal
- (ii) Visceral
- (iii) Cardiac

Flagellar movement helps in locomotion of protists like *Euglena*.

164. Answer (2)

Hint: Exclude the one with O₂ storage protein in muscle.

Sol.: Repeated activation of muscles lead to muscle fatigue which is caused due to accumulation of lactic acid in muscles, produced due to anaerobic breakdown of glycogen.

165. Answer (4)

Hint: Myelinated nerve fibres are enveloped by Schwann cells.

Sol.: Oligodendrocytes are glial cells in the CNS that produce myelin sheath. Schwann cells in PNS produce myelin sheath which envelops axon. Astrocytes provide structural support. Chondrocytes are cells of cartilage.

166. Answer (3)

Hint: Synchronisation is due to coordination.

Sol.: In our body, neural system and endocrine system jointly coordinate and integrate all the activities of the organs so that they function in a synchronised fashion.

167. Answer (3)

Hint: CNS includes brain and spinal cord.

Sol.:

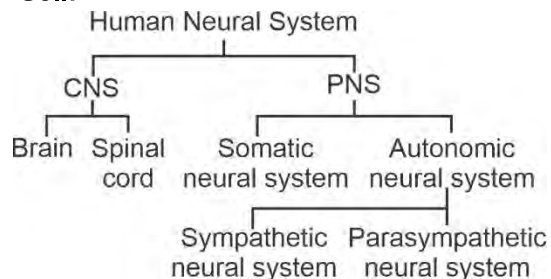

168. Answer (2)

Hint: Renin converts angiotensinogen to angiotensin I.

Sol.: The JGA plays a complex regulatory role. A fall in glomerular blood flow/glomerular blood pressure/GFR can activate JG cells to release renin which converts angiotensinogen in blood to angiotensin I.

169. Answer (4)

Hint: Secretions of sebaceous glands

Sol.: Liver, the largest gland of our body, secretes bile-containing substances like bilirubin, biliverdin, cholesterol, degraded steroid hormones, vitamins and drugs. Sebaceous glands release hydrocarbons and waxes through sebum.

170. Answer (3)

Hint: Normally 25-30 gm of it is excreted out per day.

Sol.: Glucose, albumin and ketone bodies are not present in the urine under normal conditions. Presence of glucose (glycosuria) and ketone bodies (ketonuria) in urine are indicative of diabetes mellitus.

171. Answer (2)

Hint: Inflammation of joint occurs in gout.

Sol.: Uremia – Accumulation of urea in blood.
Gout – Inflammation of joints due to accumulation of uric acid crystals.

Glomerulonephritis – Inflammation of glomeruli of kidney.

Renal calculi – Insoluble mass of crystallised salts (oxalates, etc.) formed within the kidney.

172. Answer (3)

Hint: Proteins are comparatively bigger molecules.

Sol.: The first step in urine formation is the ultrafiltration of blood which is carried out by the renal corpuscle. Blood is filtered so finely through the filtration membrane, that almost all the constituents of the plasma, except the proteins pass onto the lumen of the Bowman's capsule. Therefore, it is considered as a process of ultrafiltration.

173. Answer (2)

Hint: Half the volume of blood filtered by both the kidneys

Sol.: On an average 1100-1200 mL of blood is filtered by the kidneys per minute which constitutes roughly 1/5th of the blood pumped by each ventricle of the heart in a minute. Because both kidneys filter 1100-1200 mL, hence one kidney will filter 550-600 mL of blood.

174. Answer (3)

Hint: Bony fishes are ammonotelic

Sol.: Ammonia as it is readily soluble is generally excreted by diffusion across body surface or through gill surface (in fish) as ammonium ions.

175. Answer (3)

Hint: Concentration gradient increases from cortex towards medulla.

Sol.: The special arrangement of loop of Henle and vasa recta facilitates the counter current mechanism. This mechanism helps to maintain a concentration gradient in the medullary interstitium.

176. Answer (2)

Hint: Afferent nerves transmit impulses towards CNS.

Sol.: The spinal and cranial nerves are components of PNS and they are myelinated. The nerve fibres of PNS are of two types: afferent fibres and efferent fibres. The afferent nerve fibres transmit impulses from tissue/organs to the CNS and the efferent fibres transmit regulatory impulses from the CNS to the concerned peripheral tissues/organs.

177. Answer (1)

Hint: Show differential permeability

Sol.: Different types of ion channels are present on the neural membrane. These ion channels are selectively permeable to different ions.

178. Answer (3)

Hint: Associated with occipital bone of cranium.

Sol.: A is frontal bone which is an unpaired cranial bone. B is parietal bone which is a paired cranial bone. C is a single U-shaped bone called hyoid, present at the base of the buccal cavity. D is occipital condyle which helps in the articulation of the skull region.

179. Answer (1)

Hint: Also called false ribs

Sol.: In humans, the 8th, 9th and 10th pairs of ribs do not articulate directly with the sternum but join the seventh rib with the help of hyaline cartilage. These are called vertebrochondral (false) ribs.

180. Answer (3)

Hint: Arachnoid is the middle layer.

Sol.: Inside the skull, the brain is covered by cranial meninges consisting of an outer layer called dura mater, a very thin middle layer called arachnoid and an inner layer (which is in contact with the brain tissue) called pia mater.



All India Aakash Test Series for NEET - 2026

TEST - 3 (Code-F)[Click here for Code-E Sol.](#)

Test Date : 28/12/2025

ANSWERS

1. (3)	37. (3)	73. (4)	109. (3)	145. (2)
2. (1)	38. (1)	74. (3)	110. (4)	146. (3)
3. (1)	39. (3)	75. (1)	111. (4)	147. (4)
4. (2)	40. (1)	76. (2)	112. (4)	148. (2)
5. (3)	41. (2)	77. (4)	113. (2)	149. (3)
6. (3)	42. (3)	78. (2)	114. (3)	150. (3)
7. (2)	43. (4)	79. (1)	115. (2)	151. (4)
8. (4)	44. (2)	80. (4)	116. (4)	152. (2)
9. (2)	45. (2)	81. (2)	117. (4)	153. (3)
10. (4)	46. (1)	82. (1)	118. (2)	154. (2)
11. (4)	47. (1)	83. (1)	119. (3)	155. (4)
12. (2)	48. (4)	84. (3)	120. (4)	156. (2)
13. (3)	49. (2)	85. (4)	121. (1)	157. (4)
14. (1)	50. (3)	86. (2)	122. (3)	158. (3)
15. (3)	51. (2)	87. (1)	123. (3)	159. (2)
16. (2)	52. (4)	88. (4)	124. (4)	160. (2)
17. (4)	53. (1)	89. (1)	125. (2)	161. (4)
18. (4)	54. (2)	90. (2)	126. (1)	162. (4)
19. (3)	55. (2)	91. (1)	127. (3)	163. (2)
20. (3)	56. (4)	92. (4)	128. (2)	164. (3)
21. (2)	57. (4)	93. (1)	129. (4)	165. (4)
22. (2)	58. (1)	94. (1)	130. (4)	166. (2)
23. (2)	59. (1)	95. (4)	131. (2)	167. (3)
24. (3)	60. (2)	96. (2)	132. (1)	168. (2)
25. (3)	61. (3)	97. (3)	133. (4)	169. (2)
26. (3)	62. (3)	98. (4)	134. (1)	170. (3)
27. (2)	63. (2)	99. (2)	135. (2)	171. (3)
28. (2)	64. (2)	100. (1)	136. (3)	172. (2)
29. (4)	65. (2)	101. (4)	137. (1)	173. (4)
30. (1)	66. (3)	102. (3)	138. (3)	174. (2)
31. (3)	67. (4)	103. (4)	139. (1)	175. (4)
32. (1)	68. (2)	104. (1)	140. (2)	176. (2)
33. (1)	69. (1)	105. (4)	141. (3)	177. (2)
34. (1)	70. (2)	106. (2)	142. (3)	178. (4)
35. (3)	71. (3)	107. (3)	143. (2)	179. (3)
36. (2)	72. (4)	108. (1)	144. (3)	180. (3)

HINTS & SOLUTIONS

[PHYSICS]

1. Answer (3)

Hint: Moment of inertia of a ring about its axis is given by $I = mr^2$

Sol.: $2\pi r = \ell$

$$I = \frac{M\ell^2}{4\pi^2} = \frac{\pi \times 4}{4 \times \pi^2}$$

$$I = \frac{1}{\pi} \text{ kg m}^2$$

2. Answer (1)

Hint: Use formula $\vec{\tau} = \vec{r} \times \vec{F}$

$$\text{Sol.: } \begin{vmatrix} \hat{i} & \hat{j} & \hat{k} \\ 1 & 2 & -1 \\ -2 & 2 & 2 \end{vmatrix}$$

$$= (4+2)\hat{i} - (2-2)\hat{j} + (2+4)\hat{k}$$

$$\vec{\tau} = 6\hat{i} + 6\hat{k}$$

$$|\vec{\tau}| = 6\sqrt{2} \text{ N m}$$

3. Answer (1)

Hint and Sol.: Hooke's law holds good upto the proportional limit.

4. Answer (2)

Hint: Apply Bernoulli theorem.

$$\text{Sol.: } P_1 + \frac{1}{2}\rho v_1^2 = P_2 + \frac{1}{2}\rho v_2^2$$

$$v_1 = 0, v_2 = ?$$

$$3.5 \times 10^5 = 3 \times 10^5 + \frac{1}{2} \times 10^3 \times v_2^2$$

$$\frac{0.5 \times 10^5 \times 2}{10^3} = v_2^2 \Rightarrow v_2 = 10 \text{ m/s}$$

5. Answer (3)

Hint: Gravitational field intensity due to a point

$$\text{mass } I = \frac{GM}{r^2}$$

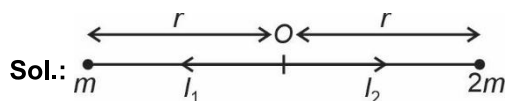

$$I_{\text{net}} = I_2 - I_1$$

$$= \frac{2Gm}{r^2} - \frac{Gm}{r^2}$$

$$= \frac{Gm}{r^2}$$

6. Answer (3)

Hint: $V_{\text{efflux}} = \sqrt{2gh}$

Sol.: From Bernoulli's equation

$$\frac{P_{\text{atm}}}{\rho g} + 3H = \frac{V^2}{2g} + \frac{P_{\text{atm}}}{\rho g} + H$$

$$\Rightarrow V = \sqrt{2gH \times 2}$$

$$= \sqrt{4gH}$$

7. Answer (2)

Hint and Sol.:

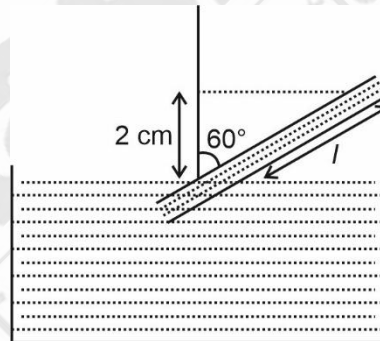

From figure, $l \cos 60^\circ = 2$

$$l \times \frac{1}{2} = 2 \Rightarrow l = 4 \text{ cm}$$

8. Answer (4)

Hint and Sol.: In a gas the rise in temperature increases the random motion of atoms and thus coefficient of viscosity increases.

9. Answer (2)

Hint: $AV = \text{constant}$

$$\text{Sol.: } 8 \times 4A = 2 \times 2A + 3 \times A \times V$$

$$32A = 4A + 3AV$$

$$3V = 28$$

$$V = \frac{28}{3} \text{ m/s}$$

10. Answer (4)

Hint: Relation between time period and radius of orbit is given by

$$T^2 \propto R^3$$

Sol.: $T^2 \propto R^3$

$$T = KR^{\frac{3}{2}}$$

$$\log T = \log(K) + \frac{3}{2} \log(R)$$

$$y = mx + c$$

11. Answer (4)

Hint and Sol.: Weight of body $W = V\rho_b g$

Buoyant force in water = $0.5 V \rho_w g$

$$\rho_b = 0.5 \rho_w$$

$$\frac{V_{\text{immersed}}}{\text{Total volume}} = \frac{\rho_{\text{Body}}}{\rho_{\text{Liquid}}} = \frac{0.5}{1.5} = \frac{1}{3}$$

Percentage of volume immersed in liquid $\approx 33.33\%$

12. Answer (2)

Hint: For isothermal condition, $PV = P_1V_1 + P_2V_2$

Sol.: $\frac{4T}{R} \times R^3 = \frac{4T}{R_1} \times R_1^3 + \frac{4T}{R_2} \times R_2^3$

$$\Rightarrow R^2 = R_1^2 + R_2^2$$

$$\Rightarrow R = \sqrt{R_1^2 + R_2^2}$$

$$R = \sqrt{4 + 16} = \sqrt{20} \text{ cm}$$

13. Answer (3)

Hint: Weight of the wire is balanced by force due to surface tension.

Sol.: $mg = 2T\ell$

$$m \times 10 = 2 \times 6 \times 10^{-2} \times 0.4$$

$$m \times 10 = 4.8 \times 10^{-2}$$

$$m = 4.8 \times 10^{-3} \text{ g}$$

14. Answer (1)

Hint: Surface tension force will balance the weight of the water between the plates.

Sol.: Let the length of the plate be l and h is the height rise between the plates.

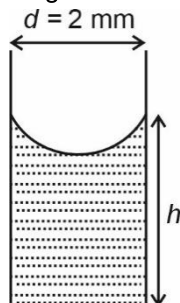

$$2Tl = \rho dlhg$$

Put all the values in cgs.

$$2 \times 22.3 = 1 \times \frac{2}{10} \times h \times 1000$$

$$h = 2.23 \text{ mm}$$

15. Answer (3)

Hint: A soap film on a frame has two surfaces.

Sol.: $PE = 2TA$

$$= 2 \times 40 \times 10^{-3} \times 8 \times 10^{-3}$$

$$= 640 \times 10^{-6}$$

$$= 64 \times 10^{-5} \text{ J}$$

16. Answer (2)

Hint: $P + \frac{1}{2} \rho v^2 + \rho gh = \text{constant}$

Sol.: Bernoulli's theorem is derived from conservation of energy and applies to non-viscous, incompressible and steady flow.

$$P + \frac{1}{2} \rho v^2 + \rho gh = \text{constant}$$

\Rightarrow Pressure energy per unit volume + kinetic energy per unit volume + potential energy per unit volume = constant

Fluid speed is maximum where pressure is minimum.

17. Answer (4)

Hint: Excess pressure inside a drop, $\Delta P = \frac{2T}{r}$

Sol.: $\Delta P = \frac{2T}{r}$

$$\frac{2T}{r_1} = \frac{6 \times 2T}{r_2}$$

$$\frac{r_2}{r_1} = 6 \Rightarrow \frac{A_2}{A_1} = \left(\frac{r_2}{r_1}\right)^2 = \frac{36}{1}$$

18. Answer (4)

Hint and Sol.: For uniform hollow sphere, field inside the sphere is zero while potential remains constant.

For a solid sphere $V_{\text{centre}} = \frac{3}{2} V_{\text{surface}}$

19. Answer (3)

Hint: Use formula $\vec{E} = -\frac{\partial V}{\partial r} \hat{r}$

Sol.: $V = -kx^3y^2$

$$\vec{E} = -\frac{\partial V}{\partial x}\hat{i} - \frac{\partial V}{\partial y}\hat{j} - \frac{\partial V}{\partial z}\hat{k}$$

$$= k \times 3x^2y^2\hat{i} + kx^3 \times (2y)\hat{j}$$

$$= 3kx^2y^2\hat{i} + 2x^3yk\hat{j}$$

$$(\vec{E})_{(2,1,0)} = (3 \times k \times 4 \times 1)\hat{i} + (2 \times 8 \times 1)k\hat{j}$$

$$= 12k\hat{i} + 16k\hat{j}$$

20. Answer (3)

Hint: Gravitational field inside earth is given by

$$g(r) = \frac{GMr}{R^3}$$

Sol.: Acceleration due to gravity at height $\frac{R}{4}$ from

$$\text{the surface of earth, } g(h) = \frac{GM}{\left(R + \frac{R}{4}\right)^2} = \frac{GM}{\left(\frac{5R}{4}\right)^2}$$

$$= \frac{16GM}{25R^2}$$

$$g(h) = \frac{16}{25}g$$

Gravitational field inside earth at $r = \frac{R}{4}$

$$g' = \frac{g}{4}$$

$$\therefore g(h) = \frac{64}{25}g'$$

21. Answer (2)

Hint: Torque of hinge force about hinge is zero.

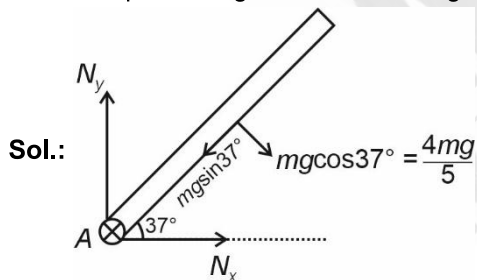

Taking torque about hinge, $\Sigma\tau = I\alpha$

$$\left(\frac{4mg}{5}\right)\frac{l}{2} = \frac{ml^2}{3}\alpha$$

$$\alpha = \frac{6g}{5l}$$

22. Answer (2)

Hint: Apply momentum and energy conservation

Sol.: $\vec{P}_i = \vec{P}_f \Rightarrow 2 \times 10 = 10 \times v' \Rightarrow v' = 2 \text{ m/s}$

$$\frac{1}{2}mv^2 + 0 = \frac{1}{2}(M+m)v'^2 + mgh$$

On solving

$$\frac{1}{2} \times 2 \times 10^2 = \frac{1}{2} \times 10 \times 2^2 + 2 \times 10 \times h$$

$$h = 4 \text{ m}$$

23. Answer (2)

Hint: Use principle of conservation of angular momentum.

Sol.: $L = I\omega$

$$\therefore \tau_{\text{net}} = 0 \Rightarrow L = \text{constant}$$

For sphere $I = \frac{2}{5}MR^2$

$$\omega = \frac{2\pi}{T}$$

$$I_1\omega_1 = I_2\omega_2 \Rightarrow R_1^2 \cdot \frac{1}{T_1} = R_2^2 \cdot \frac{1}{T_2}$$

$R = \text{initial radius, initial time} = 24 \text{ hrs}$

$$R^2 \times \frac{1}{24} = \left(\frac{R}{2}\right)^2 \cdot \frac{1}{T_2} \Rightarrow T_2 = 6 \text{ hrs}$$

24. Answer (3)

Hint: Gravitational field $g = -\frac{\Delta V}{\Delta x}$

Sol.: $g = -\frac{\Delta V}{\Delta x} = -\frac{(-5)}{20}$

$$= \frac{1}{4} \text{ J/kg m}$$

Work done in moving a mass of 4 kg from the surface to a point 10 m above the surface.

$$W = mgh = 4 \times \frac{1}{4} \times 10 = 10 \text{ J}$$

25. Answer (3)

Hint and Sol.: The shell behaves like a point mass located at its center but only for points outside the shell. Due to absence of atmosphere on moon, atmospheric pressure is zero.

26. Answer (3)

Hint: Use manometric equation

Sol.: $P_B + \rho_2g(5+H) - \rho_1g5 = P_A$

$$P_A = P_B = P_{\text{atm}}$$

$$H = \left(\frac{2.5 - 0.8}{0.8}\right)5$$

$$= 10.625 \text{ cm}$$

27. Answer (2)

Hint and Sol.: Angular momentum, $L = mvr$

For a satellite close to surface of planet

$$v_0 = \sqrt{\frac{GM}{R}} = \frac{v_e}{\sqrt{2}}$$

i.e. $v_e = \sqrt{2}v_0$

28. Answer (2)

Hint: $W_{\text{ext}} = U_f - U_i$

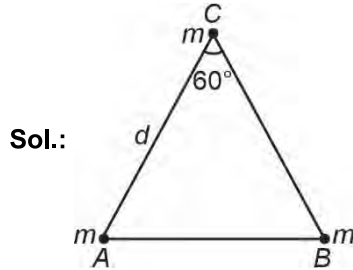

$$U_i = U_{12} + U_{23} + U_{31}$$

$$U_i = -\frac{3Gmm}{d} = -\frac{3Gm^2}{d}$$

$$U_f = -\frac{3Gm^2}{2d}$$

$$\Rightarrow WD = U_f - U_i = \frac{3Gm^2}{2d}$$

$$= \frac{3}{2}G \times \frac{4}{4}$$

$$= \frac{3}{2}GJ$$

29. Answer (4)

Hint and Sol.: Escape velocity is independent of angle of projection.

30. Answer (1)

Hint: Moment of inertia, $I = \Sigma mr^2$

Sol.: Moment of inertia does not depend on angular acceleration.

31. Answer (3)

Hint: Use conservation of angular momentum.

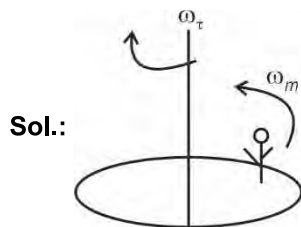

$$L_i = L_f$$

$$\omega_t = \frac{I_m \omega_m}{I_t}$$

$$\omega_m = \frac{v}{r} = 5 \text{ rad/s}$$

$$\omega_t = 150 \times \frac{1}{25} \times \frac{5}{3000}$$

$$= \frac{30}{3000} = \frac{1}{100} \text{ rad/s}$$

32. Answer (1)

Hint and Sol.: R.D = Density of body/Density of reference substance (water).

The weight of a plastic bag full of air is same as that of an empty plastic bag because air inside the bag displaces an equal amount of air outside and force of upthrust is equal to weight of air enclosed.

$$\rho_l V_d g_{\text{eff}} = mg_{\text{eff}}$$

$$V_d = \frac{m}{\rho_l}$$

33. Answer (1)

Hint and Sol.: For an ideal rigid body, bulk modulus is infinite.

Modulus of rigidity is the characteristic of solid material only.

34. Answer (1)

Hint and Sol.: $\frac{U}{V} = \frac{1}{2} \times \text{Stress} \times \text{Strain}$

$$\text{Strain} = \frac{\Delta L}{L} \Rightarrow \text{Dimensionless}$$

Reciprocal of bulk modulus is known as compressibility.

Breaking point is the point on stress-strain curve beyond which material breaks.

35. Answer (3)

Hint and Sol.:

Young's modulus depends on

- (1) Nature of material
- (2) Impurities
- (3) Temperature

Young's modulus is independent from both stress and strain

36. Answer (2)

Hint: Use equation $Y = \frac{FL}{A\Delta L}$

Sol.: Stress = $\frac{F}{A}$, for a smaller radius, area is less so stress is higher for the same force.

$$\text{Strain} = \frac{\Delta L}{L} \text{ and } Y = \frac{\text{Stress}}{\text{Strain}}$$

$$\text{Strain} = \frac{\text{Stress}}{Y}$$

So higher stress (due to smaller area) leads to greater strain and thus greater elongation.

37. Answer (3)

Hint: $K = \frac{1}{2}I\omega^2$ and $\omega = \omega_0 + \alpha t$

Sol.: $\omega_0 = 40 \text{ rad/s}$

$\alpha = -2 \text{ rad/s}^2$

$K = \frac{1}{2}I\omega^2 \Rightarrow K \propto \omega^2$

For same kinetic energy, magnitude of ω should be same.

$\omega = \omega_0 + \alpha t$

$-40 = 40 - 2 \times t$

$\Rightarrow t = 40 \text{ s}$

38. Answer (1)

Hint: Total energy of satellite moving in circular orbit, $E = -\frac{GMm}{2R}$

Sol.: When radius is doubled (i.e. $R \rightarrow 2R$)

$$E' = -\frac{GMm}{2 \cdot (2R)} = \frac{E}{2}$$

39. Answer (3)

Hint: Apply formula $y_{cm} = \frac{\int y dm}{\int dm}$

Sol.: $y_{cm} = \frac{\int y dm}{\int dm} = \frac{\int y \times \lambda A dy}{\int \lambda A dy}$

$$y_{cm} = \frac{\int_0^1 y \times a(1+by^2) dy}{\int_0^1 a(1+by^2) dy} = \frac{\int_0^1 (y + by^3) dy}{\int_0^1 (1+by^2) dy}$$

$$y_{cm} = \frac{\left(\frac{y^2}{2} + \frac{by^4}{4}\right)_0^1}{\left(y + \frac{by^3}{3}\right)_0^1} = \frac{\frac{1}{2} + \frac{b}{4}}{1 + \frac{b}{3}} = \frac{3(2+b)}{4(3+b)}$$

40. Answer (1)

Hint: $x_{cm} = \frac{m_1x_1 + m_2x_2}{m_1 + m_2}$

Sol.: Let centre O of disc be at origin.

Due to symmetry COM of remaining part will be on the x-axis.

$$m = \frac{\pi\left(\frac{R}{2}\right)^2 M}{\pi R^2} = \frac{M}{4}$$

and COM of circular hole will lie at $x = \frac{R}{2}$

For remaining part

$$x_{cm} = \frac{M \times 0 - \frac{M}{4}\left(\frac{R}{2}\right)}{M - \frac{M}{4}} = -\frac{R}{6} = -\frac{1}{2} \text{ m}$$

41. Answer (2)

Hint: Use, $F_{net} = m \times a_{COM}$

Sol.: $a_{COM} = \frac{F_{net}}{M_{total}} = \frac{6}{6} = 1 \text{ m/s}^2$

$\Rightarrow v_{COM} = a_{COM} \times t = 1 \times 5 = 5 \text{ m/s}$

42. Answer (3)

Hint: $g = \frac{GM}{R^2}$, $\frac{\Delta g}{g} = \frac{\Delta M}{M} - 2 \frac{\Delta R_e}{R_e}$

Sol.: $\frac{\Delta g}{g} \times 100 = \frac{\Delta M}{M} \times 100 - 2 \frac{\Delta R_e}{R_e} \times 100$

$= 2\% - 2 \times (-1\%)$

$= 2 + 2 = +4\%$

The percentage change in value of g is of approximately +4%.

43. Answer (4)

Hint: Use energy conservation

Sol.: $mgh = \frac{1}{2}mv^2 + \frac{1}{2}I\omega^2$ and, $I = \frac{mr^2}{2}$ and $\omega = \frac{v}{r}$

$\Rightarrow mgh = \frac{mv^2}{2} + \frac{1}{2} \times \frac{mv^2}{2}$

$\Rightarrow 4 \times 10 \times 3 = 2v^2 + v^2$

$\Rightarrow 3v^2 = 120$

$\Rightarrow v = \sqrt{40} = 2\sqrt{10} \text{ m/s}$

44. Answer (2)

Hint: Force applied by the person during climbing is internal force for the system.

$$\text{Sol.: } \vec{v}_{\text{cm}} = 0$$

$$M\vec{V} + m\vec{v} = 0$$

$$\frac{m\Delta\vec{r}_1}{\Delta t} + \frac{M\Delta\vec{r}_2}{\Delta t} = 0$$

Let d_1 is the distance climbed by the man w.r.t. ground and d_2 is the distance moved by the balloon w.r.t. ground.

$$d_1 = L - d_2$$

$$md_1 - Md_2 = 0$$

$$md_1 = Md_2$$

$$m(L - d_2) = Md_2$$

$$d_2 = \frac{mL}{m+M} = \frac{50 \times 20}{(50+150)}$$

$$= \frac{1000}{200} = 5 \text{ m}$$

45. Answer (2)

Hint: No external torque is acting on the system about the axis of rotation of disc.

$$\text{Sol.: } \vec{L}_{\text{initial}} = \vec{L}_{\text{final}}$$

$$2 \times 20 \times 1 = \frac{1}{2} \times 20 \times 1^2 \times \omega$$

$$\omega = 4 \text{ rad/s}$$

$$e = \frac{\omega R}{20}$$

$$\Rightarrow e = \frac{4}{20} = \frac{1}{5}$$

[CHEMISTRY]

46. Answer (1)

Hint: $2\text{H}^+(\text{aq}) + 2\text{e}^- \rightarrow \text{H}_2(\text{g})$

$$E_{\text{H}^+/\text{H}_2} = E^\circ_{\text{H}^+/\text{H}_2} - \frac{0.0591}{2} \log \frac{p_{\text{H}_2}}{[\text{H}^+]^2}$$

$$\text{Sol.: } E_{\text{H}^+/\text{H}_2} = 0 - \frac{0.0591}{2} \log \frac{1}{(10^{-5})^2}$$

$$= -\frac{0.0591}{2} \log 10^{10}$$

$$= -\frac{0.0591}{2} \times 10 = -0.296$$

47. Answer (1)

Hint: For strong electrolytes, Λ_m increases slowly with dilution and can be represented by the equation:

$$\Lambda_m = \Lambda_m^\circ - AC^2$$

Sol.: NaCl, CaCl₂ and MgSO₄ are 1 – 1, 2 – 1 and 2 – 2 electrolytes respectively.

48. Answer (4)

Hint: pH of acidic buffer = $\text{p}K_a + \log \frac{[\text{Salt}]}{[\text{Acid}]}$

pH of salt of strong acid and weak base

$$= 7 - \frac{1}{2}(\text{p}K_b + \log c)$$

Sol.:

(a) mmol of HCl = $100 \times 0.01 = 1$

mmol of NaOH = $100 \times 0.008 = 0.8$

$$[\text{H}^+] = \frac{1-0.8}{200} = 1 \times 10^{-3}$$

$$\text{pH} = 3$$

(b) $K_a = C\alpha^2$

$$\alpha = \sqrt{\frac{K_a}{C}} = \sqrt{\frac{1.8 \times 10^{-4}}{0.2}} = 3 \times 10^{-2}$$

$$[\text{H}^+] = C\alpha = 0.2 \times 3 \times 10^{-2} = 6 \times 10^{-3}$$

$$\text{pH} = 3 - \log 6 = 3 - [\log 2 + \log 3]$$

$$\text{pH} = 3 - (0.3 + 0.477)$$

$$\text{pH} = 2.22$$

$$(c) \text{pH} = 7 - \frac{1}{2}(4.75 + \log 0.4)$$

$$\text{pH} = 7 - 2.175 = 4.83$$

(d)

	$\text{CH}_3\text{COOH} +$	NaOH	\rightarrow	$\text{CH}_3\text{COONa} +$	H_2O
Initial	200×0.2	200×0.04		–	0
	$= 40 \text{ mmol}$	$= 8 \text{ mmol}$			
Final	32 mmol	0		8 mmol	

$$\text{pH} = 4.76 + \log \frac{8}{32}$$

$$= 4.76 - 0.6 = 4.16$$

49. Answer (2)

Hint: $\text{C}_3\text{H}_8 + 5\text{O}_2 \rightarrow 3\text{CO}_2 + 4\text{H}_2\text{O}$

$$\Delta_r H^\circ = \sum a_i \Delta_f H^\circ(\text{products}) - \sum b_i \Delta_f H^\circ(\text{reactant})$$

$$\text{Sol.: } \Delta_r H^\circ = 3 \times (-394) + 4 \times (-286) - (-104)$$

$$= -1182 - 1144 + 104$$

$$\Delta_r H^\circ = -2222 \text{ kJ mol}^{-1}$$

50. Answer (3)

Hint: As the container is insulated the process is adiabatic hence $q = 0$

$$\text{Sol.: Work done (w)} = -P(\Delta V)$$

$$= -4(6.8 - 4.2)$$

$$= -10.4 \text{ L atm}$$

From first law we know

$$\Delta U = q + w$$

$$\Delta U = 0 - 10.4$$

$$\Delta U = -10.4 \times 101.3$$

$$\Delta U = -1053.5 \text{ J}$$

51. Answer (2)

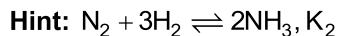

hence for $2\text{NH}_3 \rightleftharpoons \text{N}_2 + 3\text{H}_2$ the equilibrium

constant will be $\frac{1}{K_2}$

Sol.:

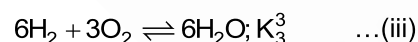
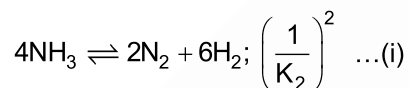

Adding equations (i), (ii) and (iii) we get,

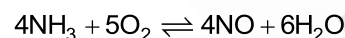

$$K = \frac{K_1^2 K_3^3}{K_2^2}$$

52. Answer (4)

Hint: For sparingly soluble salt M_xX_y if $s \text{ mol L}^{-1}$ is

$$\text{the solubility then } s = \left(\frac{K_{sp}}{x^x \cdot y^y}\right)^{\frac{1}{x+y}}$$

Sol.:

• For compound AB

$$s^2 = 1 \times 10^{-14}$$

$$s = 10^{-7} \text{ mol L}^{-1}$$

• For compound X_2Y

$$4s^3 = 4 \times 10^{-24}$$

$$s = 10^{-8} \text{ mol L}^{-1}$$

• For compound P_2Q_3

$$108s^5 = 1.08 \times 10^{-28}$$

$$108s^5 = 108 \times 10^{-30}$$

$$s = 10^{-6} \text{ mol L}^{-1}$$

53. Answer (1)

$$\text{Hint: Degree of dissociation } (\alpha) = \frac{\Lambda_m}{\Lambda_m^\circ}$$

$$\text{Sol.: } \alpha = \frac{12}{400} = 0.03$$

For weak acid, $K = C\alpha^2$

$$K = 0.05 \times (0.03)^2$$

$$K = 4.5 \times 10^{-5}$$

54. Answer (2)

Hint and Sol.: In the most stable state of aggregation of an element, the enthalpy of formation is considered to be zero.

55. Answer (2)

$$\text{Hint: } 2\Lambda_m^\circ(\text{NH}_4\text{OH}) = 2\Lambda_m^\circ(\text{NH}_4\text{Cl}) + \Lambda_m^\circ\{\text{Ba}(\text{OH})_2\} - \Lambda_m^\circ(\text{BaCl}_2)$$

$$\text{Sol.: } 2\Lambda_m^\circ(\text{NH}_4\text{OH}) = 2y + x - z$$

$$\Lambda_m^\circ(\text{NH}_4\text{OH}) = y + \frac{x}{2} - \frac{z}{2} \text{ (S cm}^2 \text{ mol}^{-1}\text{)}$$

56. Answer (4)

$$\text{Hint: } \Delta H = \Delta U + \Delta n_g RT$$

Δn_g = The number of moles of gaseous products minus the number of moles of gaseous reactants.

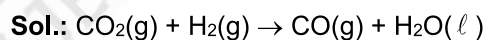

$$\Delta n_g = 1 - 2 = -1$$

$$\Delta H = \Delta U - RT$$

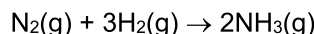

$$\Delta n_g = 2 - 4 = -2$$

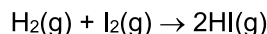

$$\Delta n_g = 2 - 2 = 0$$

$$\Delta H = \Delta U$$

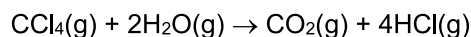

$$\Delta n_g = 5 - 3 = 2$$

$$\Delta H = \Delta U + 2RT$$

57. Answer (4)

Hint: For a chemical reaction at equilibrium, Gibbs energy change (ΔG) of the reaction is zero.

Sol.:

• At equilibrium, $\Delta G^\circ = -RT \ln K$

• For spontaneous process;

$$\Delta S_{\text{total}} = \Delta S_{\text{system}} + \Delta S_{\text{surr}} > 0$$

58. Answer (1)

$$\text{Hint: } R = \frac{\rho \ell}{A} \quad \dots(i)$$

$$\kappa = \frac{1}{\rho} \quad \dots(ii)$$

$$\text{Sol.: } A = \pi r^2 = 3.14 \times 0.4 \times 0.4 \text{ cm}^2$$

From (i) we can write

$$\rho = \frac{RA}{\ell} = \frac{5 \times 10^3 \times 3.14 \times 0.4 \times 0.4}{40}$$

$$\rho = 62.8 \text{ ohm cm}$$

$$\kappa = \frac{1}{\rho} = \frac{1}{62.8} = 1.6 \times 10^{-2} \text{ S cm}^{-1}$$

59. Answer (1)

Hint: For mercury cell, overall reaction is

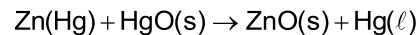

Sol.: The cell potential of mercury cell is approximately 1.35 V and remains constant during its life as the overall reaction does not involve any ion in solution whose concentration can change during its life

60. Answer (2)

Hint: Reduction potential of Na^+ is very low (-2.71 V)

Sol.: Reduction potential of $\text{H}^+(\text{aq})$ is zero, hence H_2 gas is liberated at cathode.

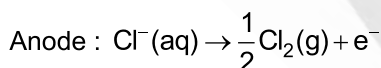
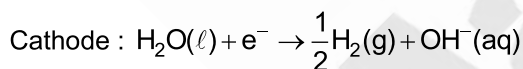
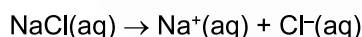

Net reaction :

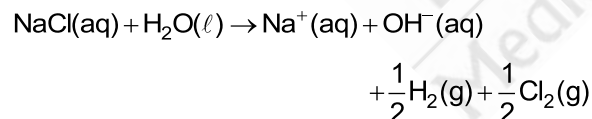

61. Answer (3)

Hint: During phase change from solid to gaseous state, the entropy increases.

Sol.: On decomposition, the number of particles increases hence entropy increases.

62. Answer (3)

Hint: Mixture of RNH_2 and RNH_3^{\oplus} in aqueous medium will act as basic buffer.

$$\text{pOH} = \text{p}K_b + \log \frac{[\text{Salt}]}{[\text{Base}]}$$

Sol.:

	RNH_2	+	HCl	\rightarrow	$\text{RNH}_3^{\oplus}\text{Cl}^-$
Initial	100×0.2		160×0.1		–
	$= 20 \text{ mmol}$		$= 16 \text{ mmol}$		
Final	4 mmol		0		16 mmol

$$\text{pOH} = (4 - \log 4) + \log \frac{16}{4}$$

$$\text{pOH} = 3.4 + 0.6$$

$$\text{pOH} = 4.0$$

$$\text{pH} = 14 - 4 = 10$$

63. Answer (2)

Hint: $\Delta H = \Delta U + \Delta n_g RT$ and $\Delta G = \Delta H - T\Delta S$

$$\text{Sol.: } \Delta H = 12 + 3 \times 8.314 \times 300 \times 10^{-3}$$

$$\Delta H = 12 + 7.48 = 19.48 \text{ kJ}$$

$$\Delta G = \Delta H - T\Delta S$$

$$= 19.48 - 300 \times 80 \times 10^{-3}$$

$$= (19.48 - 24) \text{ kJ}$$

$$= -4.52 \text{ kJ}$$

64. Answer (2)

Hint: A catalyst increases the rate of forward and reverse reactions that pass through the same transition state and does not affect the equilibrium.

Sol.: Since a catalyst does not affect the equilibrium hence it does not affect equilibrium composition of reaction mixture.

65. Answer (2)

$$\text{Hint: } \text{pOH} = 14 - 10 = 4$$

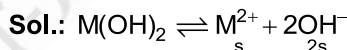

{s is the solubility of M(OH)_2 }

$$\text{pOH} = 4$$

$$[\text{OH}^-] = 10^{-4}$$

$$2s = 10^{-4}$$

$$s = \frac{1}{2} 10^{-4}$$

$$K_{\text{sp}} \text{ of } \text{M(OH)}_2 = [\text{M}^{2+}] [\text{OH}^-]^2$$

$$= s (2s)^2$$

$$= \frac{1}{2} \times 10^{-4} \times (10^{-4})^2$$

$$K_{\text{sp}} = \frac{1}{2} \times 10^{-12} = 5 \times 10^{-13}$$

66. Answer (3)

Hint: Lewis acids are electron deficient species.

Sol.: Conjugate base is obtained by removing one proton from the given species.

Equilibrium constant (K_w) depends on temperature.

67. Answer (4)

Hint: Higher is the value of reduction potential of metal cation, lower is the reducing power of the metal.

Sol.: Reduction potential of Mg^{2+}/Mg is most negative hence is easier to oxidise Mg and it is the best reducing agent in the given options.

Reduction potential of Cu^{2+}/Cu couple is maximum and positive hence it is difficult so oxidise copper. Copper is not a good reducing agent.

68. Answer (2)

Hint: Sum of oxidation number of elements in a compound is zero.

Sol.: For $X_2(YZ_2)_2$, sum of oxidation number is zero.

69. Answer (1)

Hint: E°_{cell} is intensive property while ΔG° is extensive property.

Sol.:

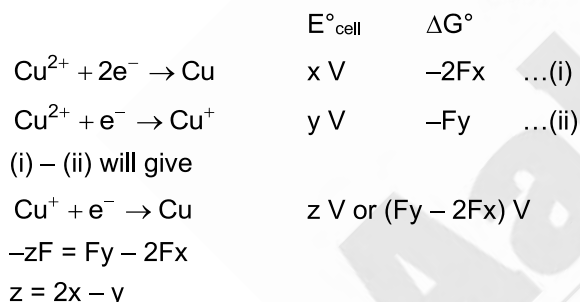

70. Answer (2)

Hint: NaOH is the limiting reagent.

Sol.: 1 equivalent of NaOH on reaction with 1 equivalent of H_2SO_4 will release 57.1 kJ of energy.

Number of milliequivalents of NaOH = $400 \times 0.4 = 160$

Number of milliequivalents of $H_2SO_4 = 300 \times 0.4 \times 2 = 240$

NaOH is limiting

Heat released on neutralisation = $160 \times 10^{-3} \times 57.1$

= 9.1 kJ

71. Answer (3)

Hint: Ethene molecule breaks as

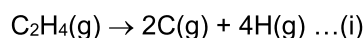

Hess's law of constant heat summation is applied.

Sol.:

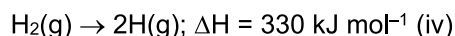
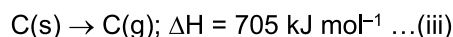
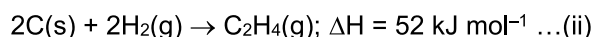

$2 \times (iii) + 2(iv) - (ii)$ will give equation (i)

$$\Delta H \text{ for (i)} = 2 \times 705 + 2 \times 330 - 52$$

$$= 1410 + 660 - 52$$

$$= 2018 \text{ kJ mol}^{-1}$$

Equation (i) involves breaking of 4 C – H bonds and 1 C = C bond

ΔH for eq. (i) = 4 × bond energy of C – H + bond energy of C = C bond

$$\text{Bond energy of C = C bond} = 2018 - 4 \times 350$$

$$= 2018 - 1400$$

$$= 618 \text{ kJ mol}^{-1}$$

72. Answer (4)

Hint: More is the disorderness, more is the entropy

Sol.: In conversion of ice to water, the randomness of molecules increases leading to a positive value of ΔS .

During phase change, at given pressure and temperature, the solid-liquid system practically remains at equilibrium and $\Delta G = 0$

73. Answer (4)

Hint: Conductivity of copper ($5.9 \times 10^3 \text{ S m}^{-1}$) is higher than sodium ($2.1 \times 10^3 \text{ S m}^{-1}$) at 298.15 K

Sol.: Conductivity always decreases with decrease in concentration both, for weak and strong electrolytes.

74. Answer (3)

Hint: Having same charge, the smaller cations are more solvated leading to decreased ionic mobility and decreased molar conductivity.

Sol.: OH^- has exceptionally high value of molar conductivity in water at 298 K.

Mg^{2+} is smaller in size than Ca^{2+} hence Mg^{2+} is more solvated and its molar conductivity is lesser than Ca^{2+} ions in water at 298 K.

75. Answer (1)

Hint: $\Delta_r G^\circ = -nFE^\circ_{cell}$

$$\text{Sol.: } E^\circ_{\text{cell}} = E^\circ_{\text{R}} - E^\circ_{\text{L}}$$

$$= E^\circ_{\text{Cu}^{2+}/\text{Cu}} - E^\circ_{\text{Al}^{3+}/\text{Al}} = 0.34 + 1.66 = 2.0 \text{ V}$$

For the given reaction, $n = 6$

$$\Delta_r G^\circ = -nFE^\circ_{\text{cell}}$$

$$= -6 \times 96500 \times 2$$

$$= -1158 \text{ kJ mol}^{-1}$$

76. Answer (2)

Hint: Internal energy is the state function, hence

$$\Delta U_{\text{ABC}} = -\Delta U_{\text{CBA}}$$

Sol.: For the process, $A \rightarrow B$

$$\Delta U_{\text{AB}} = q_{\text{AB}} + w_{\text{AB}}$$

$$\Delta U_{\text{AB}} = 4 - 8 = -4 \text{ kJ mol}^{-1}$$

For the process $B \rightarrow C$

$$\Delta U_{\text{BC}} = -7 \text{ kJ mol}^{-1}$$

$$\Delta U_{\text{ABC}} = \Delta U_{\text{AB}} + \Delta U_{\text{BC}} = -4 - 7 = -11 \text{ kJ mol}^{-1}$$

For the process, $A \rightarrow B \rightarrow C$

$$\Delta U_{\text{CBA}} = -\Delta U_{\text{ABC}} = \Delta U_{\text{CA}} = 11 \text{ kJ mol}^{-1}$$

For the process $C \rightarrow A$

$$\Delta U_{\text{CA}} = q_{\text{CA}} + w_{\text{CA}}$$

$$q_{\text{CA}} = 11 - 2 = 9 \text{ kJ mol}^{-1}$$

77. Answer (4)

Hint: SO_3^{2-} is oxidised to sulphate while MnO_4^- is reduced to Mn^{2+} .

Sol.:

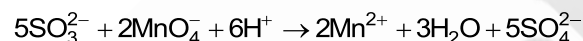

78. Answer (2)

Hint: Iodine gives intense blue colour with starch

Sol.:

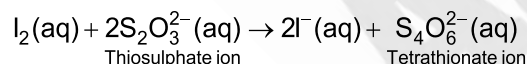

79. Answer (1)

Hint: The salt formed in the reaction will go anionic hydrolysis.

$$\text{pH} = 7 + \frac{1}{2}(\text{p}K_a + \log c)$$

Sol.:

	CH_3COOH	+	NaOH	\rightarrow	CH_3COONa	+	H_2O
Initial	$40 \times 0.1 =$ 4 mmol		$10 \times 0.4 =$ 4 mmol		-		-
Final	0		0		4 mmol		

$$\text{Concentration of } \text{CH}_3\text{COONa} = \frac{4}{50} = 0.08$$

$$\text{pH} = 7 + \frac{1}{2}(\text{p}K_a + \log c)$$

$$= 7 + \frac{1}{2}(4.76 + \log 0.08)$$

$$= 7 + \frac{1}{2}(4.76 - 1.1)$$

$$\text{pH} = 8.83$$

80. Answer (4)

Hint: Solubility of AgBr will decrease in the presence of common ion derived from sodium bromide.

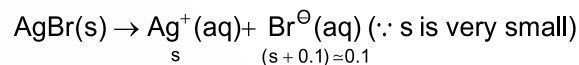
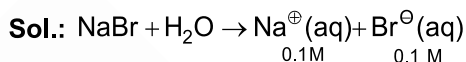

$$s \times 0.1 = 5 \times 10^{-13}$$

$$s = \frac{5 \times 10^{-13}}{0.1} = 5 \times 10^{-12}$$

$$s = 5 \times 10^{-12} \text{ M}$$

81. Answer (2)

Hint: The salts which undergo anionic hydrolysis makes the solution alkaline.

Sol.: Salts of weak acid and strong base undergo anionic hydrolysis, making solution alkaline in nature.

Same is true for sodium phenoxide and sodium benzoate

82. Answer (1)

Hint: Down the group, acidity of hydrides (HA) increases. (A is a chalcogen)

Sol.: Down the group, size of the element (A) increases as a result H-A bond strength decreases and so the acid strength increases.

83. Answer (1)

Hint: A metal in a compound can be displaced by another metal in the uncombined state. This is called metal displacement reaction.

Sol.:

• Combination reaction:

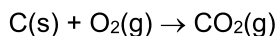

• Decomposition reaction:

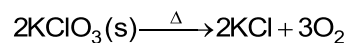

• Metal displacement reaction

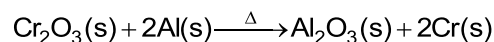

• Non-metal displacement reaction

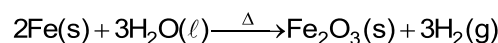

84. Answer (3)

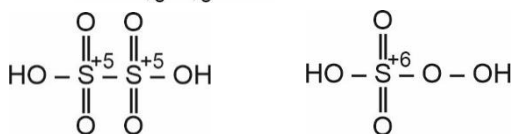
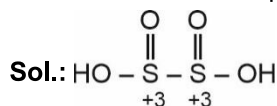
Hint: H_2SO_5 contains peroxide linkage.

85. Answer (4)

Hint: For reversible isothermal process, the work done

$$w = -2.303nRT \log \frac{V_f}{V_i}$$

$$\text{Sol.: } w = -2.303 \times 2 \times 8.314 \times 300 \log \frac{20}{5}$$

$$w = -6.89 \text{ kJ}$$

$$\Delta H = nC_p \Delta T$$

Since the process is isothermal $\Delta H = 0$

86. Answer (2)

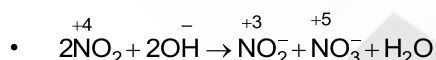
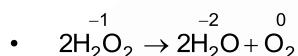
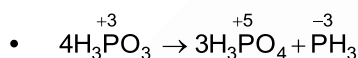
Hint: In a disproportionation reaction an element in one oxidation state is simultaneously oxidised and reduced.**Sol.:** Given below are the disproportionation reaction.

87. Answer (1)

Hint: Dry cell is also known as Leclanche cell.**Sol.:**

- In Leclanche cell (Dry cell), zinc container acts as anode while carbon (graphite) rod surrounded by powdered manganese dioxide and carbon acts as cathode.
- In the primary batteries, the reaction occurs only once and after use over a period of time battery becomes dead and cannot be reused again.

88. Answer (4)

Hint: 1 Faraday charge will deposit 1 g equivalent of copper at cathode.**Sol.:**

$$\text{Number of Faradays passed} = \frac{1.158 \times 60 \times 60}{96500}$$

$$\text{Mass of copper deposited} = \frac{1.158 \times 60 \times 60}{96500} \times \frac{63.5}{2}$$

$$= 1.37 \text{ g}$$

89. Answer (1)

$$\text{Hint: } \Lambda_m = \frac{1000 \times k}{C}$$

$$\text{Sol.: } \Lambda_m = \frac{1000 \times 2.8 \times 10^{-2}}{0.2}$$

$$= 140 \text{ S cm}^2 \text{ mol}^{-1}$$

90. Answer (2)

$$\text{Hint: } \Delta G^\circ = -2.303 \times RT \log K_C$$

$$\text{Sol.: } K_C = \frac{[\text{B}]^2 [\text{C}]}{[\text{A}]}$$

$$K_C = \frac{(0.4)^2 \times 0.2}{0.4} = 0.08$$

$$\Delta G^\circ = -2.303 \times 8.314 \times 10^{-3} \times 300 \times \log 0.08$$

$$= 6.3 \text{ kJ mol}^{-1}$$

[BOTANY]

91. Answer (1)

Hint: Cells of endodermis are rich in starch grains and hence it is called starch sheath.**Sol.:** Dicot stem has starch sheath. Endodermis is absent in monocot stem.

92. Answer (4)

Hint: In roots, pericycle forms lateral roots.**Sol.:** In both dicot and monocot root, pericycle is made up of living parenchyma cells.

93. Answer (1)

Hint: Under water stress, bulliform cells become flaccid.**Sol.:** In flaccid condition, bulliform cells curl the leaf inward.

94. Answer (1)

Hint: Isobilateral leaves are found in monocots.**Sol.:** Isobilateral leaves have equal distribution of stomata on both the surfaces. They have bulliform cells and conjoint vascular bundles.

95. Answer (4)

Hint: Companion cells are found in the phloem.**Sol.:** Companion cell is a part of vascular tissue system.

96. Answer (2)
Hint: Conjunctive tissue is found in roots.
Sol.: Conjunctive tissue is found between xylem and phloem in roots.
97. Answer (3)
Hint: Epidermal hairs are found in both roots and shoots.
Sol.: Roots have radial vascular bundles and these are not surrounded by bundle sheath cells.
98. Answer (4)
Hint: All tissues on the innerside of the endodermis constitute stele.
Sol.: Stele includes pericycle, pith and vascular bundles.
99. Answer (2)
Hint: This is T.S. of a monocot stem.
Sol.: Here,
 A – Epidermis – It can have cuticle and trichomes.
 B – Hypodermis – It is sclerenchymatous in monocot stem but absent in roots.
 C – Vascular bundles – They have water containing cavities.
 D – Xylem – Stem has endarch protoxylem.
100. Answer (1)
Hint: Collenchyma is referred as living mechanical tissue.
Sol.: Both collenchyma and sclerenchyma are mechanical tissues.
101. Answer (4)
Hint: Trichomes are not found in roots.
Sol.: Trichomes cannot help in absorption of water rather this process is done by root hairs.
102. Answer (3)
Hint: Innermost layer of cortex is endodermis.
Sol.: Pericycle forms semi-lunar patches of sclerenchyma in dicot stem.
103. Answer (4)
Hint: Casparian strips are found on endodermal cells of roots.
Sol.: Casparian strips are suberin depositions on radial and tangential walls of barrel shaped endodermal cells.
104. Answer (1)
Hint: Pith is absent in leaves.
Sol.: Well developed pith is found in monocot roots and dicot stems.
105. Answer (4)
Sol.: Mesophyll cells are not included in stomatal apparatus.
106. Answer (2)
Hint: Dicot leaves and monocot stems both have conjoint and closed vascular bundles.
Sol.: Both of them have vascular bundles of different sizes and they lack cambium. Monocot stem has parenchymatous and sclerenchymatous cells in ground tissue while in leaves, mesophyll (parenchymatous cells) constitutes ground tissue.
107. Answer (3)
Hint: This is a dead tissue.
Sol.: Sclereids are found in fruit wall of nuts.
108. Answer (1)
Hint: Epidermal cells are usually single layered.
Sol.: Epidermal cells are parenchymatous cells having large nucleus and small amount of cytoplasm. Root hairs are unicellular.
109. Answer (3)
Hint: Wall of guard cells which is towards the pore is thick.
Sol.: Inner wall of guard cells is thick while outer wall is thin.
110. Answer (4)
Hint: Hypodermis is a multi-layered structure found in stem.
Sol.: Hypodermis is absent in roots.
111. Answer (4)
Hint: Bryophytes do not have strobili.
Sol.: *Polytrichum* lacks strobili.
112. Answer (4)
Sol.: *Lycopodium* is included in class Lycopsidea.
113. Answer (2)
Hint: Conifers have needle like leaves.
Sol.: Needle like leaves have reduced surface area.
114. Answer (3)
Hint: Pteridophytes are first tracheophytes.
Sol.: Pteridophytes lack pollen grains. These are found in narrow geographical regions. Bryophytes are first embryophytes.

115. Answer (2)
Hint: *Cycas* and *Marchantia* are dioecious.
Sol.: In *Cycas* and *Marchantia*, male and female sex organs are produced on separate plant bodies.
116. Answer (4)
Hint: Bryophytes are of little economic but great ecological importance.
Sol.: Prevention of soil erosion is an ecological importance of bryophytes.
117. Answer (4)
Hint: Red algae shows complex post-fertilisation events.
Sol.: *Fucus* being brown alga lacks complex post-fertilisation events.
118. Answer (2)
Hint: In *Cycas*, megasporophylls do not aggregate compactly.
Sol.: *Cycas* lacks female cones.
119. Answer (3)
Hint: Each female gametophyte of gymnosperm has 2 or more archegonia.
Sol.: During megasporogenesis, one megaspore mother cell undergoes meiosis to form four megaspores out of which only one undergoes development to form female gametophyte.
120. Answer (4)
Hint: Some pteridophytes are homosporous.
Sol.: *Dryopteris* is homosporous. Rest all are heterosporous.
121. Answer (1)
Hint: Gametophytes are haploid.
Sol.: Gametophytes are dependent structures in gymnosperms.
122. Answer (3)
Hint: *Eudorina* shows anisogamy.
Sol.: *Pinus*, *Polytrichum* and *Pteris* has archegonia as they show oogamy.
123. Answer (3)
Hint: *Selaginella* being a pteridophyte has sporophytic main plant body.
Sol.: Meiosis in spore mother cell (b)
 → Formation of micro and megaspores (e)
 → Formation of female gametophyte (d)
 → Male gamete swim and reaches to archegonia (c)
 → Zygote forms embryo (a)
124. Answer (4)
Hint: Prothallus is a gametophytic structure.
Sol.: Prothallus is haploid.
125. Answer (2)
Hint: Protonema is first stage of gametophytic generation.
Sol.: Protonema is green structure that arises from spore.
126. Answer (1)
Hint: In algae and bryophytes, main plant body is gametophytic.
Sol.: *Salvinia*, being pteridophyte has sporophytic main body.
127. Answer (3)
Hint: Structures of gametophytic stage contain haploid set of chromosomes.
Sol.: Antherozoids, rhizoids, protonema – Gametophytic (n)
 Capsule, seta – Sporophytic (2n)
128. Answer (2)
Hint: Carrageen is found in red algae.
Sol.: Carrageen – *Gracilaria*
 Filamentous form – *Ectocarpus*
 Algin – *Sargassum*
 Body contains main axis with branches – *Polysiphonia*.
129. Answer (4)
Hint: Red algae are mostly found in warmer area.
Sol.: Majority of red algae are marine with greater concentration found in warmer area.
130. Answer (4)
Hint: Frond is mostly seen in the members of brown algae.
Sol.: *Dictyota*, *Laminaria* and *Porphyra* have frond. *Ulothrix* lacks frond.
131. Answer (2)
Hint: Red algae reproduce by non-motile spores and gametes.
Sol.: Both red and brown algae are found in marine water. Both have chlorophyll a and produce complex carbohydrates. Brown algae produce biflagellate zoospores but red algae do not.

132. Answer (1)

Hint: These are thin-walled cells.

Sol.: Monocots generally lack phloem parenchyma.

133. Answer (4)

Hint: Bast fibres are sclerenchymatous in nature.

Sol.: Bast fibres are made up of dead cells.

134. Answer (1)

Hint: Dicot leaves are dorsiventral leaves.

Sol.: In dicot leaves, abaxial surface bears more stomata than adaxial surface. Spongy mesophyll has air cavities. Both upper and lower surfaces have cuticle.

135. Answer (2)

Hint: Monocot roots have polyarch xylem.

Sol.: Dicot roots have 2-4 xylem and phloem patches.

[ZOOLOGY]

136. Answer (3)

Hint: Arachnoid is the middle layer.

Sol.: Inside the skull, the brain is covered by cranial meninges consisting of an outer layer called dura mater, a very thin middle layer called arachnoid and an inner layer (which is in contact with the brain tissue) called pia mater.

137. Answer (1)

Hint: Also called false ribs

Sol.: In humans, the 8th, 9th and 10th pairs of ribs do not articulate directly with the sternum but join the seventh rib with the help of hyaline cartilage. These are called vertebrochondral (false) ribs.

138. Answer (3)

Hint: Associated with occipital bone of cranium.

Sol.: A is frontal bone which is an unpaired cranial bone. B is parietal bone which is a paired cranial bone. C is a single U-shaped bone called hyoid, present at the base of the buccal cavity. D is occipital condyle which helps in the articulation of the skull region.

139. Answer (1)

Hint: Show differential permeability

Sol.: Different types of ion channels are present on the neural membrane. These ion channels are selectively permeable to different ions.

140. Answer (2)

Hint: Afferent nerves transmit impulses towards CNS.

Sol.: The spinal and cranial nerves are components of PNS and they are myelinated. The nerve fibres of PNS are of two types: afferent fibres and efferent fibres. The afferent nerve fibres transmit impulses from tissue/organs to the CNS and the efferent fibres transmit regulatory impulses from the CNS to the concerned peripheral tissues/organs.

141. Answer (3)

Hint: Concentration gradient increases from cortex towards medulla.

Sol.: The special arrangement of loop of Henle and vasa recta facilitates the counter current mechanism. This mechanism helps to maintain a concentration gradient in the medullary interstitium.

142. Answer (3)

Hint: Bony fishes are ammonotelic

Sol.: Ammonia as it is readily soluble is generally excreted by diffusion across body surface or through gill surface (in fish) as ammonium ions.

143. Answer (2)

Hint: Half the volume of blood filtered by both the kidneys

Sol.: On an average 1100-1200 mL of blood is filtered by the kidneys per minute which constitutes roughly 1/5th of the blood pumped by each ventricle of the heart in a minute. Because both kidneys filter 1100-1200 mL, hence one kidney will filter 550-600 mL of blood.

144. Answer (3)

Hint: Proteins are comparatively bigger molecules.

Sol.: The first step in urine formation is the ultrafiltration of blood which is carried out by the renal corpuscle. Blood is filtered so finely through the filtration membrane, that almost all the constituents of the plasma, except the proteins pass onto the lumen of the Bowman's capsule. Therefore, it is considered as a process of ultrafiltration.

145. Answer (2)

Hint: Inflammation of joint occurs in gout.

Sol.: Uremia – Accumulation of urea in blood.

Gout – Inflammation of joints due to accumulation of uric acid crystals.

Glomerulonephritis – Inflammation of glomeruli of kidney.

Renal calculi – Insoluble mass of crystallised salts (oxalates, etc.) formed within the kidney.

146. Answer (3)

Hint: Normally 25-30 gm of it is excreted out per day.

Sol.: Glucose, albumin and ketone bodies are not present in the urine under normal conditions. Presence of glucose (glycosuria) and ketone bodies (ketonuria) in urine are indicative of diabetes mellitus.

147. Answer (4)

Hint: Secretions of sebaceous glands

Sol.: Liver, the largest gland of our body, secretes bile-containing substances like bilirubin, biliverdin, cholesterol, degraded steroid hormones, vitamins and drugs. Sebaceous glands release hydrocarbons and waxes through sebum.

148. Answer (2)

Hint: Renin converts angiotensinogen to angiotensin I.

Sol.: The JGA plays a complex regulatory role. A fall in glomerular blood flow/glomerular blood pressure/GFR can activate JG cells to release renin which converts angiotensinogen in blood to angiotensin I.

149. Answer (3)

Hint: CNS includes brain and spinal cord.

Sol.:

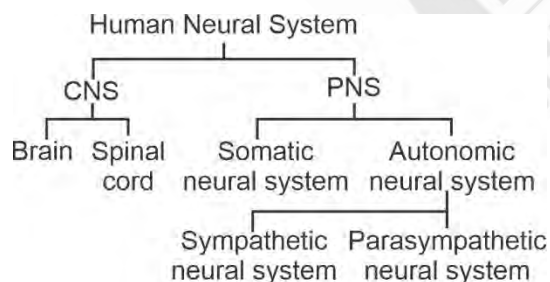

150. Answer (3)

Hint: Synchronisation is due to coordination.

Sol.: In our body, neural system and endocrine system jointly coordinate and integrate all the activities of the organs so that they function in a synchronised fashion.

151. Answer (4)

Hint: Myelinated nerve fibres are enveloped by Schwann cells.

Sol.: Oligodendrocytes are glial cells in the CNS that produce myelin sheath. Schwann cells in PNS produce myelin sheath which envelops axon. Astrocytes provide structural support. Chondrocytes are cells of cartilage.

152. Answer (2)

Hint: Exclude the one with O₂ storage protein in muscle.

Sol.: Repeated activation of muscles lead to muscle fatigue which is caused due to accumulation of lactic acid in muscles, produced due to anaerobic breakdown of glycogen.

153. Answer (3)

Hint: Macrophages perform amoeboid movement.

Sol.: Muscles have been classified using different criteria namely location, appearance and nature of regulation of their activities. Based on their location, three types of muscles are identified:

- (i) Skeletal
- (ii) Visceral
- (iii) Cardiac

Flagellar movement helps in locomotion of protists like *Euglena*.

154. Answer (2)

Hint: Involves flagellar movement

Sol.: Flagellar movement helps in the swimming of human spermatozoa. Passage of ova through female reproductive tract, movement of mucus in specific direction in human respiratory tract and movement of food through cytopharynx in *Paramecium* are facilitated by ciliary movement.

155. Answer (4)

Hint: Aldosterone causes Na⁺ reabsorption.

Sol.: Angiotensin II, being a powerful vasoconstrictor, increases the glomerular blood pressure. It also acts on adrenal cortex to release aldosterone. Aldosterone causes reabsorption of Na⁺ and water from the DCT.

156. Answer (2)

Hint: Selective secretion of K⁺ and H⁺ occurs here

Sol.: The collecting duct allows passage of small amounts of urea into the medullary interstitium to keep up the osmolarity. Descending limb of loop of Henle is almost impermeable to electrolytes and ascending limb is impermeable to water.

157. Answer (4)

Hint: True for PCT

Sol.: The PCT of renal tubule is lined by simple cuboidal brush border epithelium which increases the surface area for reabsorption. Nearly all of the essential nutrients, 70-80 per cent of the electrolytes and water are reabsorbed by this segment.

158. Answer (3)

Hint: Podocytes

Sol.: The epithelial cells of Bowman's capsule called podocytes are arranged in an intricate manner so as to leave some minute spaces called filtration slits or slit pores. Basement substance is an acellular layer.

159. Answer (2)

Hint: Equal to the number of digits in our right hand.

Sol.: The brain is the central information processing organ of our body and acts as the 'command and control system'. It controls the voluntary movements, balance of the body, functioning of vital involuntary organs, thermoregulation, circadian rhythms of our body.

160. Answer (2)

Hint: Neurotransmitters are released here

Sol.: At a chemical synapse, the membranes of the pre- and post-synaptic neurons are separated by a fluid-filled space called synaptic cleft. Receptors are present on post-synaptic membrane.

161. Answer (4)

Hint: Both actin and myosin present in this portion.

Sol.: When skeletal muscle fibres are contracted maximally, the size of sarcomere and isotropic band gets reduced while the size of anisotropic band remains the same.

162. Answer (4)

Hint: Each limb has 30 bones.

Sol.: Tarsals in both hindlimbs – 14

Carpals in both forelimbs – 16

Phalanges in both forelimbs and both hindlimbs – 56

Total number of bones in both hindlimbs – 60

163. Answer (2)

Hint: Neuromuscular junction is affected in Myasthenia gravis.

Sol.: Myasthenia gravis – Autoimmune disorder affecting neuromuscular junction.

Muscular dystrophy – Progressive degeneration of skeletal muscles mostly due to genetic disorder.

164. Answer (3)

Hint: Both have the protein that stores O₂ in the muscles

Sol.: Both white and red muscle fibres have myoglobin but red muscle fibres have abundance of it. Red muscle fibres are rich in mitochondria while white muscle fibres have less mitochondria. White muscle fibres are rich in sarcoplasmic reticulum. Red muscle fibres undergo aerobic process for energy production while white muscle fibres depend on anaerobic process.

165. Answer (4)

Hint: Choose the joint between flat skull bones.

Sol.: Gliding joint is present between carpals while saddle joint is present between carpal and metacarpal of thumb. These joints are synovial joints. Pivot joint is present between atlas and axis and it is also a synovial joint. Cartilaginous joint is present between adjacent vertebrae in the vertebral column except between atlas and axis. Flat skull bones fuse end-to-end with the help of dense fibrous connective tissue in the form of sutures, to form cranium.

166. Answer (2)

Hint: Exclude the features of skeletal muscle fibres

Sol.: Smooth muscle is present in GI tract. Smooth muscle fibres are unstriated, unbranched, fusiform, uninucleated and involuntary. They also possess gap junctions. Skeletal muscle fibres are syncytial and are voluntary in nature.

167. Answer (3)

Hint: Prawn has green glands.

Sol.: Protonephridia/flame cells are the excretory structures in rotifers, flatworms, some annelids and the cephalochordates – *Amphioxus*.

Antennal glands or green glands perform the excretory function in crustaceans like prawns.

168. Answer (2)

Hint: Ammonia is the most toxic nitrogenous waste.

Sol.: Terrestrial adaptation necessitated the production of lesser toxic nitrogenous wastes like urea and uric acid for conservation of water. Ammonia is the most toxic form and requires large amount of water for its elimination.

169. Answer (2)

Hint: Cortical nephrons are more in number.

Sol.: Cortical nephrons are more in number in comparison to juxtamedullary nephrons. Cortical nephrons have very short loop of Henle while juxtamedullary nephrons have very long loop of Henle. Peritubular capillary network is present in both cortical and juxtamedullary nephrons.

170. Answer (3)

Hint: Allows passage of small amounts of urea

Sol.: The renal tubule begins with a double-walled cup-like structure called Bowman's capsule. The tubule further continues to form a highly coiled network *i.e.*, PCT. A hairpin shaped loop of Henle is the next part which has a descending and an ascending limb. The ascending limb continues as another highly coiled region called DCT. The DCTs of many nephrons open into a straight tube called collecting duct.

171. Answer (3)

Hint: Thin filament

Sol.: During muscle contraction, actin filaments slide over the myosin filament which results in shortening of muscle. Myosin is thick filament and is polymer of meromyosin.

Collagen fibres are proteinaceous fibres found in connective tissues.

172. Answer (2)

Hint: Also helps in transformation of host cells.

Sol.: The increased levels of Ca^{++} leads to the binding of calcium with a subunit of troponin on actin filament and thereby remove the masking of active sites for myosin.

173. Answer (4)

Hint: Joints act as fulcrum.

Sol.: Joints are essential for all the types of movements involving the bony parts of the body. Locomotory movements are no exception to this.

174. Answer (2)

Hint: Identify the option with longest bone

Sol.: The bones of forelimbs are humerus, radius, ulna, carpals, metacarpals and phalanges.

175. Answer (4)

Hint: Part of appendicular skeleton

Sol.: Sacrum and coccyx are fused vertebral bones. Coxal bones make up the pelvic girdle. Each coxal bone is formed by the fusion of three bones – ilium, ischium and pubis. Each forelimb possess 8 carpals. Carpals are the wrist bones.

176. Answer (2)

Hint: Dorsally placed in human body

Sol.: In humans, the skull region articulates with the superior region of the vertebral column with the help of two occipital condyles.

177. Answer (2)

Hint: Regulated by hypothalamus

Sol.: The hypothalamus contains centres which controls urge for eating and drinking. The medulla oblongata contains centres which control respiration, cardiovascular reflexes and gastric secretions.

178. Answer (4)

Hint: Most hind part of hindbrain

Sol.: The inner parts of cerebral hemispheres and a group of associated deep structures like amygdala, hippocampus, *etc.* form a complex structure called the limbic system. Medulla oblongata is not the structural component of limbic system.

179. Answer (3)

Hint: Possesses neurosecretory cells

Sol.: Hypothalamus lies at the base of the thalamus. Limbic system along with the hypothalamus is involved in the regulation of sexual behaviour. Corpus callosum is a tract of nerve fibres that connects two cerebral hemispheres. Pons and cerebellum are parts of the hindbrain.

180. Answer (3)

Hint: Exclude the part of midbrain and hindbrain

Sol.: The forebrain of humans consists of cerebrum, thalamus and hypothalamus. Midbrain, pons and medulla oblongata together make up the brain stem. Cerebellum is a part of hindbrain.

Cerebral aqueduct is a canal that passes through the midbrain.

