



ANSWERS & HINTS
for
WBJEE - 2022
SUB : MATHEMATICS

CATEGORY - I (Q:1 to Q50)

(Carry 1 mark each. Only one option is correct. Negative marks – ¼)

1. Two circle $S_1 = px^2 + py^2 + 2g'x + 2f'y + d = 0$ and $S_2 = x^2 + y^2 + 2gx + 2fy + d' = 0$ have a common chord PQ. The equation of PQ is

(A) $S_1 - S_2 = 0$ (B) $S_1 + S_2 = 0$ (C) $S_1 - pS_2 = 0$ (D) $S_1 + pS_2 = 0$

Ans : (C)

Hint : $\frac{S_1}{p} - S_2 = 0 \Rightarrow S_1 - pS_2 = 0$

2. If the sum of the distances of a point from two perpendicular lines in a plane is 1 unit, then its locus is

(A) a square (B) a circle (C) a straight line (D) two intersecting lines

Ans : (A)

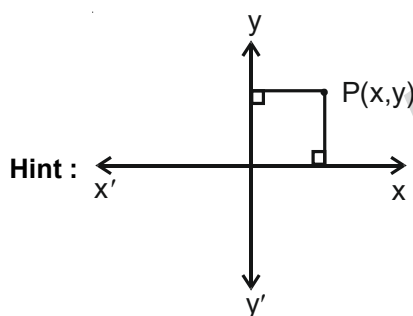

$$|x| + |y| = 1$$

Locus is square

3. A line passes through the point $(-1, 1)$ and makes an angle $\sin^{-1}\left(\frac{3}{5}\right)$ in the positive direction of x-axis. If this line meets the curve $x^2 = 4y - 9$ at A and B, then $|AB|$ is equal to

(A) $\frac{4}{5}$ unit (B) $\frac{5}{4}$ unit (C) $\frac{3}{5}$ unit (D) $\frac{5}{3}$ unit

Ans : (B)

Hint : $4y - 3x = 7$ and $x^2 = 4y - 9$

On solving, $x^2 - 3x + 2 = 0 \Rightarrow x = 1, 2$ and $y = \frac{5}{2}, \frac{13}{4}$

$A\left(1, \frac{5}{2}\right)$ and $B\left(2, \frac{13}{4}\right)$

$|AB| = \frac{5}{4}$

4. AB is a chord of a parabola $y^2 = 4ax$, ($a > 0$) with vertex A. BC is drawn perpendicular to AB meeting the axis at C. The projection of BC on the axis of the parabola is

- (A) a unit (B) 2 a unit (C) 8a unit (D) 4a unit

Ans : (D)

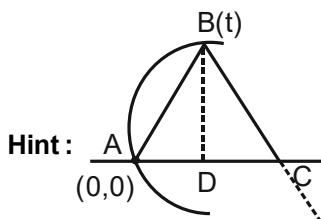

$B(at^2, 2at) \therefore D(at^2, 0)$

$m_{AB} = \frac{2at}{at^2} = \frac{2}{t} \therefore m_{BC} = -\frac{t}{2}$

$\therefore y - 2at = -\frac{t}{2}(x - at^2)$ [Equation of BC]

for $y = 0, -2at = -\frac{t}{2}(x - at^2) = -\frac{t}{2}x + \frac{at^3}{2}$

$\Rightarrow tx = 4at + at^3$

$\Rightarrow x = 4a + at^2$

$\therefore C(4a + at^2, 0)$

\therefore Projection of BC on the axis is $DC = AC - AD = 4a + at^2 - at^2 = 4a$

5. Let $P(3 \sec \theta, 2 \tan \theta)$ $Q(3 \sec \phi, 2 \tan \phi)$ be two points on $\frac{x^2}{9} - \frac{y^2}{4} = 1$ such that $\theta + \phi = \frac{\pi}{2}, 0 < \theta, \phi < \frac{\pi}{2}$. Then the ordinate of the point of intersection of the normals at P and Q is

- (A) $\frac{13}{2}$ (B) $-\frac{13}{2}$ (C) $\frac{5}{2}$ (D) $-\frac{5}{2}$

Ans : (B)

Hint : $\frac{a^2x}{x_1} + \frac{b^2y}{y_1} = a^2 + b^2, P(3\sec\theta, 2\tan\theta)$

$\therefore \frac{9x}{3\sec\theta} + \frac{4y}{2\tan\theta} = 9 + 4 = 13$

$\Rightarrow 3x \cos\theta + 2y \cot\theta = 13 \dots\dots (1)$

Similarly, $3x \cos\phi + 2y \cot\phi = 13$

$$3x \cos\left(\frac{\pi}{2} - \theta\right) + 2y \cot\left(\frac{\pi}{2} - \theta\right) = 13$$

$$\Rightarrow 3x \sin\theta + 2y \tan\theta = 13 \dots\dots (2)$$

$$\therefore \frac{13 - 2y \cot\theta}{3 \cos\theta} = \frac{13 - 2y \tan\theta}{3 \sin\theta}$$

$$\Rightarrow 13 \sin\theta - 2y \cos\theta = 13 \cos\theta - 2y \sin\theta$$

$$\Rightarrow 13 \tan\theta - 2y = 13 - 2y \tan\theta$$

$$\Rightarrow 13(\tan\theta - 1) = -2y(\tan\theta - 1)$$

$$\therefore y = -\frac{13}{2}$$

$$\therefore \text{Ordinate} = -\frac{13}{2}$$

6. Let P be a point on (2, 0) and Q be a variable point on $(y - 6)^2 = 2(x - 4)$. Then the locus of mid-point of PQ is
 (A) $y^2 + x + 6y + 12 = 0$ (B) $y^2 - x + 6y + 12 = 0$ (C) $y^2 + x - 6y + 12 = 0$ (D) $y^2 - x - 6y + 12 = 0$

Ans : (D)

Hint : P(2, 0)

$$Q\left(4 + \frac{1}{2}t^2, 6 + t\right)$$

Let midpoint of PQ be R(h, k)

$$h = 3 + \frac{1}{4}t^2, k = 3 + \frac{t}{2}$$

$$\Rightarrow (k - 3)^2 = (h - 3)$$

$$\Rightarrow y^2 - 6y - x + 12 = 0$$

7. The line $x - 2y + 4z + 4 = 0$, $x + y + z - 8 = 0$ intersect the plane $x - y + 2z + 1 = 0$ at the point
 (A) (-2, 5, 1) (B) (2, -5, 1) (C) (2, 5, -1) (D) (2, 5, 1)

Ans : (D)

Hint : All other options are discarded

8. AB is a variable chord of the ellipse $\frac{x^2}{a^2} + \frac{y^2}{b^2} = 1$. If AB subtends a right angle at the origin O, then $\frac{1}{OA^2} + \frac{1}{OB^2}$ equals to

- (A) $\frac{1}{a^2} + \frac{1}{b^2}$ (B) $\frac{1}{a^2} - \frac{1}{b^2}$ (C) $a^2 + b^2$ (D) $a^2 - b^2$

Ans : (A)

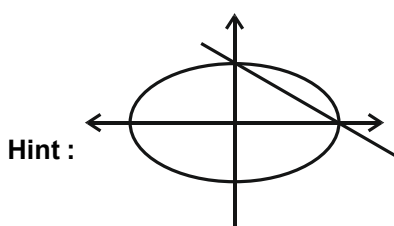

9. The equation of the plane through the intersection of the planes $x + y + z = 1$ and $2x + 3y - z + 4$ and parallel to the x -axis is
 (A) $y + 3z + 6 = 0$ (B) $y + 3z - 6 = 0$ (C) $y - 3z + 6 = 0$ (D) $y - 3z - 6 = 0$

Ans : (C)

Hint : $(2x + 3y - z + 4) + \lambda(x + y + z - 1) = 0$

$$\vec{n} = (2 + \lambda)\hat{i} + (3 + \lambda)\hat{j} + (-1 + \lambda)\hat{k}$$

$$\vec{n} \cdot \vec{i} = 0 \Rightarrow \lambda = -2$$

$$\Rightarrow y - 3z + 6 = 0$$

10. The values of a, b, c for which the function $f(x) = \begin{cases} \frac{\sin(a+1)x + \sin x}{x}, & x < 0 \\ c, & x = 0 \\ \frac{(x + bx^2)^{1/2} - \sqrt{x}}{bx^{1/2}}, & x > 0 \end{cases}$

is continuous at $x = 0$, are

(A) $a = \frac{3}{2}, b = -\frac{3}{2}, c = \frac{1}{2}$

(B) $a = -\frac{3}{2}, c = \frac{3}{2}$, b is arbitrary non-zero real number

(C) $a = -\frac{5}{2}, b = -\frac{3}{2}, c = \frac{3}{2}$

(D) $a = -2, b \in \mathbb{R} - \{0\}, c = 0$

Ans : (D)

Hint : $f(0^+) = \lim_{x \rightarrow 0^+} \frac{(1 + bx)^{1/2} - 1}{b} = 0$

$f(0) = c$

$f(0^-) = a + 2$

$\Rightarrow c = 0$ and $a = -2, b \in \mathbb{R} - \{0\}$

11. If $y = e^{\tan^{-1}x}$ then

(A) $(1 + x^2)y_2 + (2x - 1)y_1 = 0$

(B) $(1 + x^2)y_2 + 2xy_1 = 0$

(C) $(1 + x^2)y_2 - y_1 = 0$

(D) $(1 + x^2)y_2 + 3xy_1 + 4y = 0$

Ans : (A)

Hint : $\frac{dy}{dx} = e^{\tan^{-1}x} \times \frac{1}{1+x^2}$

$\Rightarrow (1 + x^2)y' = y$

or $2xy' + (1 + x^2)y'' = y'$

or $(1 + x^2)y'' + y'(2x - 1) = 0$

12. Domain of $y = \sqrt{\log_{10} \frac{3x-x^2}{2}}$ is

- (A) $x < 1$ (B) $2 < x$ (C) $1 \leq x \leq 2$ (D) $2 < x < 3$

Ans : (C)

Hint : $\log_{10} \left(\frac{3x-x^2}{2} \right) \geq 0$

or $\log_{10} \left(\frac{3x-x^2}{2} \right) \geq \log_{10} 1$

or $x^2 - 3x + 2 \leq 0$

or $x \in [1, 2]$ and $\frac{3x-x^2}{2} > 0$

$\Rightarrow x \in [1, 2]$

13. Let $f(x) = a_0 + a_1|x| + a_2|x|^2 + a_3|x|^3$, where a_0, a_1, a_2, a_3 are real constants. Then $f(x)$ is differentiable at $x = 0$

- (A) whatever be a_0, a_1, a_2, a_3
 (B) for no values of a_0, a_1, a_2, a_3
 (C) only if $a_1 = 0$
 (D) only if $a_1 = 0, a_3 = 0$

Ans : (C)

Hint : $f'(0^+) = \lim_{x \rightarrow 0^+} (a_1 + 2a_1x + 3a_3x^2) = a_1$

$f'(0^-) = \lim_{x \rightarrow 0^-} (-a_1 + 2a_1x - 3a_3x^2) = -a_1$

$f'(0^+) = f'(0^-) \Rightarrow a_1 = 0$

14. Let $f: [a, b] \rightarrow \mathbb{R}$ be continuous in $[a, b]$, differentiable in (a, b) and $f(a) = 0 = f(b)$. Then

- (A) there exists at least one point $c \in (a, b)$ for which $f'(c) = f(c)$
 (B) $f'(x) = f(x)$ does not hold at any point of (a, b)
 (C) at every point of (a, b) , $f'(x) > f(x)$
 (D) at every point of (a, b) , $f'(x) < f(x)$

Ans : (A)

Hint : Let $g(x) = e^{-x}f(x)$

$g(a) = g(b) = 0$

By Rolle's theorem, for atleast one $c \in (a, b)$ where

$g'(c) = 0$

or $e^{-c} f'(c) - f(c) e^{-c} = 0$

or $e^{-c}(f'(c) - f(c)) = 0$

or $f'(c) = f(c)$ for atleast one $c \in (a, b)$

15. $\lim_{x \rightarrow 0} \left(\frac{1}{x} \ln \sqrt{\frac{1+x}{1-x}} \right)$ is

- (A) $\frac{1}{2}$ (B) 0 (C) 1 (D) does not exist

Ans : (C)

Hint :
$$\lim_{x \rightarrow 0} \frac{\frac{1}{2}(\ln(1+x) - \ln(1-x))}{x}$$

$$= \frac{1}{2} \lim_{x \rightarrow 0} \left(\frac{1}{1+x} + \frac{1}{1-x} \right) = 1$$

16. Let f be derivable in $[0, 1]$, then

- (A) there exists $c \in (0, 1)$ such that $\int_0^c f(x) dx = (1-c)f(c)$
- (B) there does not exist any point $d \in (0, 1)$ for which $\int_0^d f(x) dx = (1-d)f(d)$
- (C) $\int_0^c f(x) dx$ does not exist, for any $c \in (0, 1)$
- (D) $\int_0^c f(x) dx$ is independent of c , $c \in (0, 1)$

Ans : (A)

Hint : Let $g(x) = x \int_0^x f(t) dt - \int_0^x f(t) dt$

Now, $g(0) = 0$

$g(1) = 0$

By Rolle's Theorem

$g'(x) = 0$ for some $x \in (0, 1)$

$g'(x) = xf(x) + \int_0^x f(t) dt - f(x) = 0$

17. $I = \int \cos(\ln x) dx$. Then $I =$

- (A) $\frac{x}{2} \{ \cos(\ln x) + \sin(\ln x) \} + c$
- (B) $x^2 \{ \cos(\ln x) - \sin(\ln x) \} + c$
- (C) $x^2 \sin(\ln x) + c$
- (D) $x \cos(\ln x) + c$

Ans : (A)

Hint :
$$\int \cos(\ln(x)) dx = x \cdot \cos(\ln x) - \int (-\sin(\ln x)) \times \frac{1}{x} (x) dx$$

$$= x \cos(\ln x) + \int \sin(\ln x) dx$$

$$= x \cos(\ln x) + x \sin(\ln x) - \int \cos(\ln x) dx$$

18. Let $\lim_{\epsilon \rightarrow 0^+} \int_{\epsilon}^x \frac{bt \cos 4t - a \sin 4t}{t^2} dt = \frac{a \sin 4x}{x} - 1, (0 < x < \frac{\pi}{4})$. Then a and b are given by

- (A) $a = 2, b = 2$
- (B) $a = \frac{1}{4}, b = 1$
- (C) $a = -1, b = 4$
- (D) $a = 2, b = 4$

Ans : (B)

Hint : Let $g(x) = \lim_{\epsilon \rightarrow 0} \int_{\epsilon}^{x} \frac{bt \cos 4t - a \sin 4t}{t^2} dt = \frac{a \sin 4x}{x} - 1$

$$\lim_{x \rightarrow 0} g(x) = 0 = 4a - 1 \Rightarrow a = \frac{1}{4}$$

$$g'(x) = \frac{bx \cos 4x - a \sin 4x}{x^2}$$

Comparing, $b = 4a = 1$

19. Let $\int \frac{x^{1/2}}{\sqrt{1-x^3}} dx = \frac{2}{3} g(f(x)) + c$; then

(A) $f(x) = \sqrt{x}, g(x) = x^{3/2}$

(B) $f(x) = x^{3/2}, g(x) = \sin^{-1} x$

(C) $f(x) = \sqrt{x}, g(x) = \sin^{-1} x$

(D) $f(x) = \sin^{-1} x, g(x) = x^{3/2}$

Ans : (B)

Hint : $\int \frac{x^{1/2} dx}{\sqrt{1-(x^{3/2})^2}} = \frac{2}{3} \int \frac{dt}{\sqrt{1-t^2}}$

$$x^{3/2} = t$$

$$\frac{3}{2} x^{1/2} dx = dt$$

$$= \frac{2}{3} \sin^{-1}(t) + c$$

$$= \frac{2}{3} \sin^{-1}(x^{3/2}) + c$$

20. The value of $\int_0^{\pi/2} \frac{(\cos x)^{\sin x}}{(\cos x)^{\sin x} + (\sin x)^{\cos x}} dx$ is

(A) $\pi/4$

(B) 0

(C) $\pi/2$

(D) $1/2$

Ans : (A)

Hint : $I = \int_0^{\pi/2} \frac{(\cos x)^{\sin x}}{(\cos x)^{\sin x} + (\sin x)^{\cos x}} dx$

$$I = \int_0^{\pi/2} \frac{(\sin x)^{\cos x}}{(\sin x)^{\cos x} + (\cos x)^{\sin x}} dx$$

$$\Rightarrow 2I = \frac{\pi}{2}$$

$$\Rightarrow I = \frac{\pi}{4}$$

21. A curve passes through the point (3, 2) for which the segment of the tangent line contained between the co-ordinate axes is bisected at the point of contact. The equation of the curve is

(A) $y = x^2 - 7$

(B) $x = \frac{y^2}{2} + 2$

(C) $xy = 6$

(D) $x^2 + y^2 - 5x + 7y + 11 = 0$

Ans : (C)

Hint : $\frac{x}{x_1} + \frac{y}{y_1} = 2$

$\therefore \left(\frac{dy}{dx}\right)_{(x_1, y_1)} = -\frac{y_1}{x_1}$

$\therefore \frac{dy}{dx} = -\frac{y}{x} \Rightarrow \frac{dy}{y} = -\frac{dx}{x} \Rightarrow \ln y = -\ln x + k \Rightarrow \ln xy = k \Rightarrow xy = e^k = C \Rightarrow xy = C$ passes through (3, 2)

$\therefore C = 3 \times 2 = 6 \therefore xy = 6$

22. Let $f(x) = \int_{\sin x}^{\cos x} e^{-t^2} dt$. Then $f'\left(\frac{\pi}{4}\right)$ equals

(A) $\sqrt{\frac{1}{e}}$

(B) $-\sqrt{\frac{2}{e}}$

(C) $\sqrt{\frac{2}{e}}$

(D) $-\sqrt{\frac{1}{e}}$

Ans : (B)

Hint : $f'(x) = -e^{-\cos^2 x} \sin x - e^{-\sin^2 x} \cos x$

$\therefore f'\left(\frac{\pi}{4}\right) = -e^{-\frac{1}{2}} \frac{1}{\sqrt{2}} - e^{-\frac{1}{2}} \frac{1}{\sqrt{2}} = -\frac{2}{\sqrt{2e}} = -\sqrt{\frac{2}{e}}$

23. If $x \frac{dy}{dx} + y = x \frac{f(xy)}{f'(xy)}$, then $|f(xy)|$ is equal to

(A) $Ce^{x^2/2}$

(B) Ce^{x^2}

(C) Ce^{2x^2}

(D) $Ce^{x^2/3}$

where C is the constant of integration

Ans : (A)

Hint : $x \frac{dy}{dx} + y = x \frac{f(xy)}{f'(xy)} \Rightarrow \frac{d(xy)}{dx} = x \frac{f(xy)}{f'(xy)} \Rightarrow \frac{f'(xy)}{f(xy)} d(xy) = x dx \Rightarrow \ln |f(xy)| = \frac{x^2}{2} + k \Rightarrow f(xy) = Ce^{\frac{x^2}{2}}$

24. Let $f(x) = (x-2)^{17}(x+5)^{24}$. Then

(A) f does not have a critical point at $x = 2$

(B) f has a minimum at $x = 2$

(C) f has neither a maximum nor a minimum at $x = 2$

(D) f has a maximum at $x = 2$

Ans : (C)

Hint : $f(x) = (x-2)^{17}(x+5)^{24}$

$\Rightarrow f'(x) = 17(x-2)^{16}(x+5)^{24} + 24(x-2)^{17}(x+5)^{23} = (x-2)^{16}(x+5)^{23}(17x+85+24x-48) = (x-2)^{16}(x+5)^{23}(41x+37)$

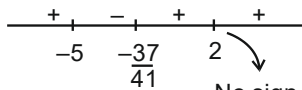

No sign change at $x = 2$
 $\Rightarrow f(x)$ has neither a maximum
 nor a minimum at $x = 2$

25. The solution of $\cos y \frac{dy}{dx} = e^{x+\sin y} + x^2 e^{\sin y}$ is $f(x) + e^{-\sin y} = C$ (C is arbitrary real constant) where $f(x)$ is equal to

- (A) $e^x + \frac{1}{2}x^3$ (B) $e^{-x} + \frac{1}{3}x^3$ (C) $e^{-x} + \frac{1}{2}x^3$ (D) $e^x + \frac{1}{3}x^3$

Ans : (D)

Hint : $-e^{-\sin y} \cos y \frac{dy}{dx} = -[e^x + x^2] \Rightarrow d(e^{-\sin y}) + (e^x + x^2)dx = 0 \Rightarrow e^{-\sin y} + e^x + \frac{x^3}{3} = C$

26. The point of contact of the tangent to the parabola $y^2 = 9x$ which passes through the point $(4, 10)$ and makes an angle θ with the positive side of the axis of the parabola where $\tan \theta > 2$, is

- (A) $(\frac{4}{9}, 2)$ (B) $(4, 6)$ (C) $(4, 5)$ (D) $(\frac{1}{4}, \frac{1}{6})$

Ans : (A)

Hint : $\tan \theta = \frac{1}{t} > 2$

Equation of tangent at t

$yt = x + \frac{9}{4}t^2$ (passes through $(4, 10)$) $\Rightarrow 10t = 4 + \frac{9}{4}t^2 \Rightarrow 9t^2 - 40t + 16 = 0 \Rightarrow t = 4, \frac{4}{9}$ ($\frac{1}{t} > 2$) $\Rightarrow t = \frac{4}{9}$

\therefore point $(at^2, 2at) \Rightarrow (\frac{4}{9}, 2)$

27. A particle moving in a straight line starts from rest and the acceleration at any time t is $a - kt^2$ where a and k are positive constants. The maximum velocity attained by the particle is

- (A) $\frac{2}{3}\sqrt{\frac{a^3}{k}}$ (B) $\frac{1}{3}\sqrt{\frac{a^3}{k}}$ (C) $\sqrt{\frac{a^3}{k}}$ (D) $2\sqrt{\frac{a^3}{k}}$

Ans : (A)

Hint : $\frac{dv}{dt} = a - kt^2 = (\sqrt{a} - \sqrt{kt})(\sqrt{a} + \sqrt{kt})$ [$\because a, k > 0$]



v will be max at $t = \sqrt{\frac{a}{k}}$

$\therefore v = at - \frac{k}{3}t^3 + C$

at $t = 0, v = 0 \Rightarrow C = 0$

$$\therefore v = at - \frac{k}{3}t^3$$

$$\begin{aligned} \therefore v_{\max} &= a\sqrt{\frac{a}{k}} - \frac{k}{3} \frac{a}{k} \sqrt{\frac{a}{k}} \\ &= \frac{2a}{3} \sqrt{\frac{a}{k}} \end{aligned}$$

28. If $\vec{a} = \hat{i} + \hat{j} - \hat{k}$, $\vec{b} = \hat{i} - \hat{j} + \hat{k}$ and \vec{c} is unit vector perpendicular to \vec{a} and coplanar with \vec{a} and \vec{b} , then unit vector \vec{d} perpendicular to both \vec{a} and \vec{c} is

- (A) $\pm \frac{1}{\sqrt{6}}(2\hat{i} - \hat{j} + \hat{k})$ (B) $\pm \frac{1}{\sqrt{2}}(\hat{j} + \hat{k})$ (C) $\pm \frac{1}{\sqrt{6}}(\hat{i} - 2\hat{j} + \hat{k})$ (D) $\pm \frac{1}{\sqrt{2}}(\hat{j} - \hat{k})$

Ans : (B)

Hint : $\therefore \vec{d}$ is normal to the plane of \vec{a} and \vec{b}

$$\vec{a} \times \vec{b} \text{ or } \vec{b} \times \vec{a} = \pm 2(\hat{j} + \hat{k}) \therefore \text{unit vector } \vec{d} = \pm \frac{1}{\sqrt{2}}(\hat{j} + \hat{k})$$

29. If the equation of one tangent to the circle with centre at (2, -1) from the origin is $3x + y = 0$, then the equation of the other tangent through the origin is

- (A) $3x - y = 0$ (B) $x + 3y = 0$ (C) $x - 3y = 0$ (D) $x + 2y = 0$

Ans : (C)

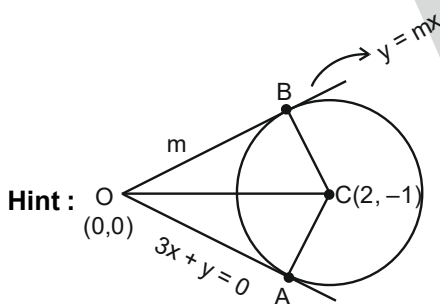

$$\therefore CA = CB$$

$$\Rightarrow \frac{5}{\sqrt{10}} = \frac{|2m + 1|}{\sqrt{1 + m^2}}$$

squaring

$$\frac{25}{10} = \frac{4m^2 + 4m + 1}{1 + m^2}$$

$$\Rightarrow 5 + 5m^2 = 8m^2 + 8m + 2 \Rightarrow 3m^2 + 8m - 3 = 0 \Rightarrow m = \frac{1}{3}, -3$$

$$\therefore \text{Equation of tangent OB is } y = \frac{x}{3}$$

30. Area of the figure bounded by the parabola $y^2 + 8x = 16$ and $y^2 - 24x = 48$ is

- (A) $\frac{11}{9}$ sq. unit (B) $\frac{32}{3}\sqrt{6}$ sq. unit (C) $\frac{16}{3}$ sq. unit (D) $\frac{24}{5}$ sq. unit

Ans : (B)

Hint : $y^2 = -8(x-2)$ -----(1)

$y^2 = 24(x+2)$ -----(2)

Solving (1) and (2) $\Rightarrow x = -1$

$$\text{Area} = 2 \left[\int_{-2}^{-1} 2\sqrt{6}\sqrt{x+2} dx + \int_{-1}^2 2\sqrt{2}\sqrt{2-x} dx \right] = \frac{32}{3}\sqrt{6} \text{ sq. unit}$$

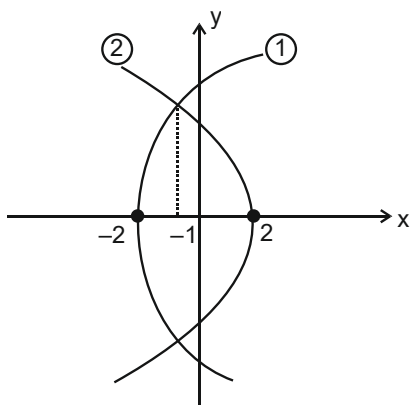

31. Let $a_n = (1^2 + 2^2 + \dots + n^2)^n$ and $b_n = n^n (n!)$. Then

- (A) $a_n < b_n \forall n$ (B) $a_n > b_n \forall n$
 (C) $a_n = b_n$ for infinitely many n (D) $a_n < b_n$ if n be even and $a_n > b_n$ if n be odd

Ans : (B)

Hint : Using PMI $a_n > b_n$ [$a_n > b_n \forall n \geq 2$ as $a_1 = b_1$]

32. If a, b, c are in G. P. and $\log a, -\log 2b, \log 2b - \log 3c, \log 3c - \log a$ are in A. P., then a, b, c are the lengths of the sides of a triangle which is

- (A) acute angled (B) obtuse angled (C) right angled (D) equilateral

Ans : (B)

Hint : $\therefore 2 \log \frac{2b}{3c} = \log \frac{a}{2b} + \log \frac{3c}{a} \Rightarrow \frac{4b^2}{9c^2} = \frac{3c}{2b} \Rightarrow 2b = 3c \Rightarrow \frac{c}{b} = \frac{2}{3}$ (common ratio)

\therefore Sides are $a, \frac{2a}{3}, \frac{4a}{9}$

Using Cosine rule

$\Rightarrow \cos A < 0 \Rightarrow$ obtuse angled triangle

33. If a, b are odd integers, then the roots of the equation $2ax^2 + (2a + b)x + b = 0, a \neq 0$ are

- (A) rational (B) irrational (C) non-real (D) equal

Ans : (A)

Hint : Disc is a perfect square \Rightarrow Rational roots

34. The number of zeros at the end of $100!$ is

- (A) 21 (B) 22 (C) 23 (D) 24

Ans : (D)

Hint : $E_5(100!) = \left[\frac{100}{5} \right] + \left[\frac{100}{25} \right] + \left[\frac{100}{125} \right] = 20 + 4 + 0 = 24$

35. If $|z - 25i| \leq 15$, then Maximum $\arg(z)$ - Minimum $\arg(z)$ is equal to

- (A) $2\cos^{-1}\left(\frac{3}{5}\right)$ (B) $2\cos^{-1}\left(\frac{4}{5}\right)$ (C) $\frac{\pi}{2} + \cos^{-1}\left(\frac{3}{5}\right)$ (D) $\sin^{-1}\left(\frac{3}{5}\right) - \cos^{-1}\left(\frac{3}{5}\right)$

Ans : (B)

Hint :

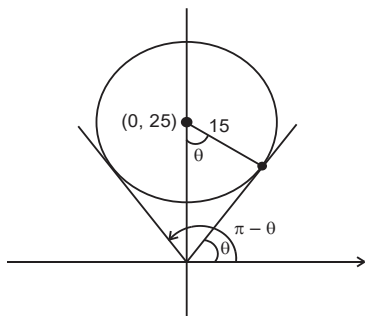

$\therefore \cos\theta = \frac{15}{25} = \frac{3}{5}$

$\therefore \text{Min arg}(z) = \cos^{-1}\left(\frac{3}{5}\right)$

$\text{Max arg}(z) = \pi - \cos^{-1}\left(\frac{3}{5}\right) = \frac{\pi}{2} + \sin^{-1}\left(\frac{3}{5}\right)$

$\therefore \text{difference} = \frac{\pi}{2} + \sin^{-1}\left(\frac{3}{5}\right) - \cos^{-1}\left(\frac{3}{5}\right) = 2\sin^{-1}\left(\frac{3}{5}\right) = 2\cos^{-1}\left(\frac{4}{5}\right)$

36. If $z = x - iy$ and $z^{\frac{1}{3}} = p + iq$ ($x, y, p, q \in \mathbb{R}$), then $\frac{\left(\frac{x}{p} + \frac{y}{q}\right)}{(p^2 + q^2)}$ is equal to

- (A) 2 (B) -1 (C) 1 (D) -2

Ans : (D)

Hint : $z = p^3 - 3pq^2 + i(3p^2q - q^3) = x - iy$

$x = p(p^2 - 3q^2)$

$y = -q(3p^2 - q^2)$

$\therefore \frac{x}{p} + \frac{y}{q} = p^2 - 3q^2 - 3p^2 + q^2 = -2(p^2 + q^2)$

37. A is a set containing n elements. P and Q are two subsets of A. Then the number of ways of choosing P and Q so that $P \cap Q = \phi$ is
 (A) $2^{2n} 2^n C_n$ (B) 2^n (C) $3^n - 1$ (D) 3^n

Ans : (D)

Hint : $\sum_{r=0}^n {}^n C_r \cdot 2^{n-r} = (2+1)^n = 3^n$ (Assuming P contains r elements then Q can be formed with $n-r$ elements in 2^{n-r} ways)

38. There are n white and n black balls marked 1, 2, 3, ..., n . The number of ways in which we can arrange these balls in a row so that neighbouring balls are of different colours is

- (A) $(n!)^2$ (B) $(2n)!$ (C) $2(n!)^2$ (D) $\frac{(2n)!}{(n!)^2}$

Ans : (C)

Hint : BW BW = $n! \times n!$

or

$$WB WB \dots = 2(n!)^2$$

39. Let $f(n) = 2^{n+1}$, $g(n) = 1 + (n+1)2^n$ for all $n \in \mathbb{N}$. Then

- (A) $f(n) > g(n)$ (B) $f(n) < g(n)$
 (C) $f(n)$ and $g(n)$ are not comparable (D) $f(n) > g(n)$ if n be even and $f(n) < g(n)$ if n be odd

Ans : (B)

Hint : $g(n) - f(n) = 1 + (n+1)2^n - 2 \cdot 2^n = 1 + n \cdot 2^n - 2^n = 1 + (n-1)2^n > 0$

$$\therefore n \geq 1 \Rightarrow (n-1) \geq 0$$

40. If $\Delta(x) = \begin{vmatrix} x-2 & (x-1)^2 & x^3 \\ x-1 & x^2 & (x+1)^3 \\ x & (x+1)^2 & (x+2)^3 \end{vmatrix}$, then coefficient of x in $\Delta(x)$ is

- (A) 2 (B) -2 (C) 3 (D) -4

Ans : (B)

Hint : co-eff of x in $\Delta(x) = \frac{\Delta'(0)}{1!} = -2$

41. Under which of the following condition(s) does(do) the system of equations $\begin{pmatrix} 1 & 2 & 4 \\ 2 & 1 & 2 \\ 1 & 2 & (a-4) \end{pmatrix} \begin{pmatrix} x \\ y \\ z \end{pmatrix} = \begin{pmatrix} 6 \\ 4 \\ a \end{pmatrix}$ possesses

(possess) unique solution ?

- (A) $\forall a \in \mathbb{R}$ (B) $a = 8$
 (C) for all integral values of a (D) $a \neq 8$

Ans : (D)

Hint : $\Delta \neq 0$

$$\Rightarrow \begin{vmatrix} 1 & 2 & 4 \\ 2 & 1 & 2 \\ 1 & 2 & a-4 \end{vmatrix} \neq 0 \Rightarrow a \neq 8$$

42. Let S, T, U be three non-void sets and $f : S \rightarrow T, g : T \rightarrow U$ and composed mapping $g \circ f : S \rightarrow U$ be defined. Let $g \circ f$ be injective mapping. Then

- (A) f, g both are injective. (B) neither f nor g is injective.
 (C) f is obviously injective. (D) g is obviously injective.

Ans : (C)

Hint : Let, $x_1, x_2 \in S$ and $f(x_1) = f(x_2)$
 $\Rightarrow g \circ f(x_1) = g(f(x_1)) = g(f(x_2)) = g \circ f(x_2)$
 $\Rightarrow x_1 = x_2$ (as $g \circ f$ is injective)
 $\Rightarrow f(x)$ is obviously injective.

43. If $p = \begin{bmatrix} 1 & \alpha & 3 \\ 1 & 3 & 3 \\ 2 & 4 & 4 \end{bmatrix}$ is the adjoint of the 3×3 matrix A and $\det A = 4$, then α is equal to

- (A) 4 (B) 11 (C) 5 (D) 0

Ans : (B)

Hint : $|p| = 2\alpha - 6 = (\det A)^2 = 16$
 $\Rightarrow \alpha = 11$

44. If $A = \begin{pmatrix} 1 & 1 \\ 0 & i \end{pmatrix}$ and $A^{2018} = \begin{pmatrix} a & b \\ c & d \end{pmatrix}$, then $(a + d)$ equals

- (A) $1 + i$ (B) 0 (C) 2 (D) 2018

Ans : (B)

Hint : $A^2 = \begin{pmatrix} 1 & 1+i \\ 0 & -1 \end{pmatrix}, A^3 = \begin{pmatrix} 1 & i \\ 0 & -i \end{pmatrix}, A^4 = I$

$$\therefore A^{2018} = A^{2016} \times A^2 = A^2 = \begin{pmatrix} 1 & 1+i \\ 0 & -1 \end{pmatrix}$$

$$\therefore a + d = 1 + (-1) = 0$$

45. A determinant is chosen at random from the set of all determinants of order 2 with elements 0 or 1 only. The probability that the determinant chosen is non-zero is

- (A) $\frac{3}{16}$ (B) $\frac{3}{8}$ (C) $\frac{1}{4}$ (D) $\frac{5}{8}$

Ans : (B)

Hint : $\begin{vmatrix} a & b \\ c & d \end{vmatrix} = ad - bc = 0$

Case 1 : $ad = bc = 0 \rightarrow 3 \times 3 = 9$ cases

Case 2 : $ad = bc = 1 \rightarrow 1$ case only

$$\therefore \text{Probability} = 1 - \frac{9+1}{2^4} = \frac{3}{8}$$

46. For the mapping $f : \mathbb{R} - \{1\} \rightarrow \mathbb{R} - \{2\}$, given by $f(x) = \frac{2x}{x-1}$, which of the following is correct ?

- (A) f is one-one but not onto
 (B) f is onto but not one-one
 (C) f is neither one-one nor onto
 (D) f is both one-one and onto

Ans : (D)

Hint : $f(x) = \frac{2x}{x-1} \Rightarrow f'(x) = \frac{-2}{(x-1)^2} < 0$

$\therefore f(x)$ is one-one

Let, $y_1 \in \mathbb{R} - \{2\}$ and $f(x_1) = y_1$

Then, $y_1 = \frac{2x_1}{x_1-1} \Rightarrow x_1 = \frac{y_1}{y_1-2} \in \mathbb{R} - \{1\}$

$\therefore f(x)$ is onto .

47. A, B, C are mutually exclusive events such that $P(A) = \frac{3x+1}{3}$, $P(B) = \frac{1-x}{4}$ and $P(C) = \frac{1-2x}{2}$. Then the set of possible values of x are in

- (A) $[0, 1]$ (B) $\left[\frac{1}{3}, \frac{1}{2}\right]$ (C) $\left[\frac{1}{3}, \frac{2}{3}\right]$ (D) $\left[\frac{1}{3}, \frac{13}{3}\right]$

Ans : (B)

Hint : $0 \leq P(A)+P(B)+P(C) \leq 1$ and $0 \leq P(A) \leq 1, 0 \leq P(B) \leq 1, 0 \leq P(C) \leq 1 \Rightarrow \frac{1}{3} \leq x \leq \frac{1}{2}$

48. The side AB of $\triangle ABC$ is fixed and is of length $2a$ unit. The vertex moves in the plane such that the vertical angle is always constant and is α . Let x -axis be along AB and the origin be at A. Then the locus of the vertex is

- (A) $x^2 + y^2 + 2ax \sin \alpha + a^2 \cos \alpha = 0$ (B) $x^2 + y^2 - 2ax - 2ay \cot \alpha = 0$
 (C) $x^2 + y^2 - 2ax \cos \alpha - a^2 = 0$ (D) $x^2 + y^2 - ax \sin \alpha - ay \cos \alpha = 0$

Ans : (B)

Hint :

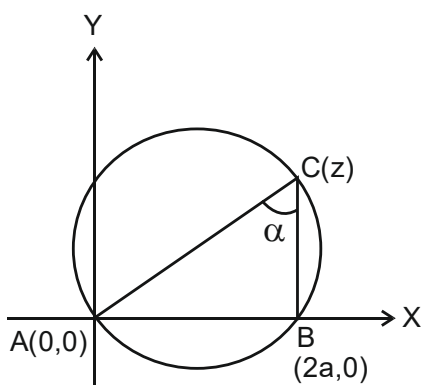

Let, $c = z = x + iy$

$$\arg \left(\frac{2a - z}{0 - z} \right) = \alpha$$

$$\Rightarrow \arg \left(\frac{(x - 2a) + iy}{x + iy} \right) = \alpha$$

$$\Rightarrow x^2 + y^2 - 2ax - 2ay \cot \alpha = 0$$

49. If $(\cot \alpha_1) (\cot \alpha_2) \dots (\cot \alpha_n) = 1$, $0 < \alpha_1, \alpha_2, \dots, \alpha_n < \pi/2$, then the maximum value of $(\cos \alpha_1) (\cos \alpha_2) \dots (\cos \alpha_n)$ is given by

- (A) $\frac{1}{2^{n/2}}$ (B) $\frac{1}{2^n}$ (C) $\frac{1}{2n}$ (D) 1

Ans : (A)

Hint : $\frac{1}{(\cos \alpha_1 \cos \alpha_2 \dots \cos \alpha_n)^2}$

$$= (1 + \tan^2 \alpha_1)(1 + \tan^2 \alpha_2) \dots (1 + \tan^2 \alpha_n)$$

$$\geq (2 \tan \alpha_1)(2 \tan \alpha_2) \dots (2 \tan \alpha_n) \text{ [AM - GM inequality]}$$

$$= 2^n \times \frac{1}{\cot \alpha_1 \cot \alpha_2 \dots \cot \alpha_n} = 2^n$$

$$\therefore \cos \alpha_1 \cos \alpha_2 \dots \cos \alpha_n \leq \frac{1}{2^{n/2}}$$

50. If the algebraic sum of the distances from the points (2, 0), (0, 2) and (1, 1) to a variable straight line be zero, then the line passes through the fixed point

- (A) (-1, 1) (B) (1, -1) (C) (-1, -1) (D) (1, 1)

Ans : (D)

Hint : $\left(\frac{2+0+1}{3}, \frac{0+2+1}{3}\right)$ i.e. (1,1).

CATEGORY - II (Q51 to Q65)

(Carry 2 marks each. Only one option is correct. Negative marks : ½)

51. PQ is a double ordinate of the hyperbola $\frac{x^2}{a^2} - \frac{y^2}{b^2} = 1$ such that ΔOPQ is an equilateral triangle, O being the centre of the hyperbola. Then the eccentricity e of the hyperbola satisfies

- (A) $1 < e < \frac{2}{\sqrt{3}}$ (B) $e = \frac{2}{\sqrt{3}}$ (C) $e = 2\sqrt{3}$ (D) $e > \frac{2}{\sqrt{3}}$

Ans : (D)

Hint : $\tan 30^\circ = \frac{b \tan \theta}{a \sec \theta}$

$$\Rightarrow \frac{b}{a} = \frac{1}{\sin \theta \sqrt{3}}$$

$$e = \sqrt{1 + \frac{1}{3 \sin^2 \theta}} > \sqrt{1 + \frac{1}{3}}$$

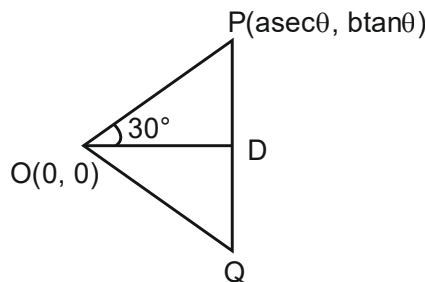

$$\Rightarrow e > \frac{2}{\sqrt{3}} \quad (0 < \sin^2 \theta < 1)$$

52. Let f be a non-negative function defined in $[0, \pi/2]$, f' exists and be continuous for all x and $\int_0^x \sqrt{1 - (f'(t))^2} dt = \int_0^x f(t) dt$ and $f(0) = 0$. Then

- (A) $f\left(\frac{1}{2}\right) < \frac{1}{2}$ and $f\left(\frac{1}{3}\right) > \frac{1}{3}$ (B) $f\left(\frac{1}{2}\right) > \frac{1}{2}$ and $f\left(\frac{1}{3}\right) < \frac{1}{3}$
 (C) $f\left(\frac{4}{3}\right) < \frac{4}{3}$ and $f\left(\frac{2}{3}\right) < \frac{2}{3}$ (D) $f\left(\frac{4}{3}\right) > \frac{4}{3}$ and $f\left(\frac{2}{3}\right) > \frac{2}{3}$

Ans : (C)

Hint : $\int_0^x \sqrt{1 - (f'(t))^2} dt = \int_0^x f(t) dt$

Using Leibnitz Rule,

$$\sqrt{1 - (f'(x))^2} = f(x)$$

$$\therefore f'(x) = \pm \sqrt{1 - f^2(x)} \Rightarrow \int \frac{df(x)}{\sqrt{1 - f^2(x)}} = \pm \int dx$$

$$\sin^{-1}(f(x)) = \pm x + c$$

$$\therefore f(x) = \sin(\pm x + C)$$

$$\therefore f(0) = 0 \Rightarrow C = 0$$

$$\therefore f(x) = \sin x \text{ or } -\sin x$$

But f is non-negative on $\left[0, \frac{\pi}{2}\right]$

$$\therefore f(x) = \sin x$$

$$\therefore f(x) < x \text{ for all } x > 0$$

$$\therefore f\left(\frac{4}{3}\right) < \frac{4}{3} \text{ and } f\left(\frac{2}{3}\right) < \frac{2}{3}$$

53. If the transformation $z = \log \tan \frac{x}{2}$ reduces the differential equation $\frac{d^2y}{dx^2} + \cot x \frac{dy}{dx} + 4y \operatorname{cosec}^2 x = 0$ into the form

$$\frac{d^2y}{dz^2} + ky = 0 \text{ then } k \text{ is equal to}$$

- (A) -4 (B) 4 (C) 2 (D) -2

Ans : (B)

Hint : $\frac{d^2y}{dz^2} = \frac{d}{dz} \left(\frac{dy}{dz} \right) = \frac{d}{dz} \left(\frac{dy}{dx} \frac{dx}{dz} \right)$

$$= \frac{d}{dz} \left(\frac{\frac{dy}{dx}}{\frac{1}{\sin x}} \right) \quad \left(\because \frac{dz}{dx} = \frac{1}{\sin x} \right)$$

$$= \frac{d}{dz} \left(\sin x \cdot \frac{dy}{dx} \right) = \frac{\frac{d}{dx} \left(\sin x \cdot \frac{dy}{dx} \right)}{\frac{dz}{dx}}$$

$$= \sin x \left[\cos x \cdot \frac{dy}{dx} + \sin x \frac{d^2y}{dx^2} \right]$$

$$\therefore \frac{d^2y}{dz^2} + ky = 0$$

$$\therefore \sin x \cdot \cos x \cdot \frac{dy}{dx} + \sin^2 x \frac{d^2y}{dx^2} + ky = 0$$

Dividing the equation by $\sin^2 x$, we get $\frac{d^2y}{dx^2} + \cot x \cdot \frac{dy}{dx} + k \cdot \operatorname{cosec}^2 x \cdot y = 0$

Comparing with the equation

$$\frac{d^2y}{dx^2} + \cot x \cdot \frac{dy}{dx} + 4 \operatorname{cosec}^2 x \cdot y = 0$$

We get $k = 4$

54. If I is the greatest of

$$I_1 = \int_0^1 e^{-x} \cos^2 x \, dx, \quad I_2 = \int_0^1 e^{-x^2} \cos^2 x \, dx, \quad I_3 = \int_0^1 e^{-x^2} \, dx, \quad I_4 = \int_0^1 e^{-x^2/2} \, dx, \text{ then}$$

- (A) $I = I_1$ (B) $I = I_2$ (C) $I = I_3$ (D) $I = I_4$

Ans : (D)

Hint : $e^{-x} \cdot \cos^2 x < e^{-x^2} \cos^2 x < e^{-x^2} < e^{-x^2/2}$ for $0 < x < 1$

\therefore By domination Law, I_4 is maximum

$\therefore I = I_4$

55. $\lim_{x \rightarrow \infty} \left(\frac{x^2 + 1}{x + 1} - ax - b \right), (a, b \in \mathbb{R}) = 0$. Then

- (A) $a = 0, b = 1$ (B) $a = 1, b = -1$ (C) $a = -1, b = 1$ (D) $a = 0, b = 0$

Ans : (B)

Hint : $\lim_{x \rightarrow \infty} \frac{x^2 + 1 - ax(x + 1) - b(x + 1)}{x + 1} = 0$

$$= \lim_{x \rightarrow \infty} \frac{(1-a)x^2 - (a+b)x + 1-b}{x+1} = 0$$

for the limit to exist,

$$1 - a = 0 \text{ and } -(a + b) = 0$$

$$\therefore a = 1, b = -1$$

56. Let the tangent and normal at any point $P(at^2, 2at)$, ($a > 0$), on the parabola $y^2 = 4ax$ meet the axis of the parabola at T and G respectively. Then the radius of the circle through P, T and G is

- (A) $a(1 + t^2)$ (B) $(1 + t^2)$ (C) $a(1 - t^2)$ (D) $(1 - t^2)$

Ans : (A)

Hint : $P(at^2, 2at)$, $T(-at^2, 0)$, $G(2a + at^2, 0)$

$$\text{Slope of PT} \times \text{Slope of PG} = -1$$

\therefore TG is a diameter of the circle through points P, T and G.

$$\therefore \text{radius} = \frac{1}{2} \text{TG} = a(1 + t^2)$$

57. From the point $(-1, -6)$, two tangents are drawn to $y^2 = 4x$. Then the angle between the two tangents is

- (A) $\pi/3$ (B) $\pi/4$ (C) $\pi/6$ (D) $\pi/2$

Ans : (D)

Hint : $(-1, -6)$ lies on the directrix of the parabola $y^2 = 4x$.

\therefore angle between tangents $= \pi/2$

58. If $\vec{\alpha}$ is a unit vector, $\vec{\beta} = \hat{i} + \hat{j} - \hat{k}$, $\vec{\gamma} = \hat{i} + \hat{k}$, then the maximum value of $[\vec{\alpha} \vec{\beta} \vec{\gamma}]$ is

- (A) 3 (B) $\sqrt{3}$ (C) 2 (D) $\sqrt{6}$

Ans : (D)

$$\text{Hint : } [\vec{\alpha} \vec{\beta} \vec{\gamma}] = \vec{\alpha} \cdot (\vec{\beta} \times \vec{\gamma}) = \vec{\alpha} \cdot \begin{vmatrix} \hat{i} & \hat{j} & \hat{k} \\ 1 & 1 & -1 \\ 1 & 0 & 1 \end{vmatrix}$$

$= \vec{\alpha} \cdot (\hat{i} + 2\hat{j} - \hat{k})$ is maximum \Rightarrow angle between $\vec{\alpha}$ & $\hat{i} + 2\hat{j} - \hat{k}$ will be 0

$$\therefore [\vec{\alpha} \vec{\beta} \vec{\gamma}] = |\vec{\alpha}| |\hat{i} + 2\hat{j} - \hat{k}| = \sqrt{6}$$

59. The maximum value of $f(x) = e^{\sin x} + e^{\cos x}$; $x \in \mathbb{R}$ is

- (A) $2e$ (B) $2\sqrt{e}$ (C) $2e^{1/\sqrt{2}}$ (D) $2e^{-1/\sqrt{2}}$

Ans : (C)

Hint : $f(x) = e^{\sin x} + e^{\cos x}$

$$f'(x) = e^{\sin x} \cdot \cos x - e^{\cos x} \cdot \sin x$$

$$\begin{aligned} f''(x) &= e^{\sin x} \cos^2 x + e^{\cos x} \cdot \sin^2 x - \sin x \cdot e^{\sin x} - \cos x \cdot e^{\cos x} \\ &= e^{\sin x} (1 - \sin x - \sin^2 x) + e^{\cos x} (1 - \cos^2 x - \cos x) \end{aligned}$$

$$f'(\pi/4) = 0 \text{ and } f''(\pi/4) < 0$$

$$f'(x) = 0 \text{ at } x = \pi/4 + 2n\pi \text{ or } 5\pi/4 + 2n\pi (n \in \mathbb{Z})$$

$$f'(\pi/4 + 2n\pi) = 0 \text{ and } f''(\pi/4 + 2n\pi) < 0$$

$$\therefore f_{\max} = f(\pi/4 + 2n\pi), n \in \mathbb{Z} = 2e^{1/\sqrt{2}}$$

60. A straight line meets the co-ordinate axes at A and B. A circle is circumscribed about the triangle OAB, O being the origin. If m and n are the distances of the tangent to the circle at the origin from the points A and B respectively, the diameter of the circle is

- (A) $m(m+n)$ (B) $m+n$ (C) $n(m+n)$ (D) $\frac{1}{2}(m+n)$

Ans : (B)

Hint : Clearly, AB is one of diameter

\therefore AM and BN are parallel and $\angle BNO = \angle AMO = \pi/2$

\therefore Points N, O and M are collinear.

\therefore \square BNMA is a rectangle

\Rightarrow $AB = MN = m + n$

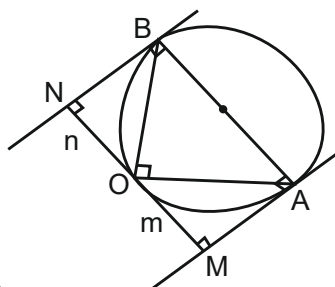

61. The solution of $\det(A - \lambda I_2) = 0$ be 4 and 8 and $A = \begin{pmatrix} 2 & 3 \\ x & y \end{pmatrix}$. Then

- (A) $x = 4, y = 10$ (B) $x = 5, y = 8$ (C) $x = 3, y = 9$ (D) $x = -4, y = 10$

Ans : (D)

Hint : $\det(A - \lambda I_2) = 0 \Rightarrow \begin{vmatrix} 2-\lambda & 3 \\ x & y-\lambda \end{vmatrix} = 0$

$$\Rightarrow (2 - \lambda)(y - \lambda) - 3x = 0$$

$$\Rightarrow 2y - \lambda y - 2\lambda + \lambda^2 - 3x = 0$$

$$\Rightarrow \lambda^2 - (y + 2)\lambda + 2y - 3x = 0$$

$$y + 2 = 4 + 8 \Rightarrow y = 10$$

$$\text{and } 2y - 3x = 4 \times 8 \Rightarrow x = -4$$

62. The value of a for which sum of the squares of the roots of the equation $x^2 - (a - 2)x - a - 1 = 0$ assumes the least value is

- (A) 0 (B) 1 (C) 2 (D) 3

Ans : (B)

Hint : Let α, β be the roots, then

$$\alpha^2 + \beta^2 = (\alpha + \beta)^2 - 2\alpha\beta$$

$$= (a - 2)^2 + 2(a + 1)$$

$$= a^2 - 2a + 6$$

$$= (a - 1)^2 + 5 \geq 5$$

$\therefore \alpha^2 + \beta^2$ is minimum if $a = 1$.

63. If x satisfies the inequality $\log_{25}x^2 + (\log_5x)^2 < 2$, then x belongs to

- (A) $\left(\frac{1}{5}, 5\right)$ (B) $\left(\frac{1}{25}, 5\right)$ (C) $\left(\frac{1}{5}, 25\right)$ (D) $\left(\frac{1}{25}, 25\right)$

Ans : (B)

Hint : Domain = $(0, \infty)$

$$\log_5 x + \left(\log_5 x\right)^2 - 2 < 0$$

$$\Rightarrow (\log_5 x - 1)(\log_5 x + 2) < 0$$

$$\therefore -2 < \log_5 x < 1$$

$$\therefore \frac{1}{25} < x < 5$$

64. $f : X \rightarrow \mathbb{R}$, $X = \{x | 0 < x < 1\}$ is defined as $f(x) = \frac{2x-1}{1-|2x-1|}$. Then

(A) f is only injective

(B) f is only surjective

(C) f is bijective

(D) f is neither injective nor surjective

Ans : (C)

Hint : Put $2x - 1 = t$, then the function becomes

$$f(t) = \frac{t}{1-|t|}, -1 < t < 1$$

$$\therefore f(t) = \begin{cases} \frac{t}{1+t}, & -1 < t \leq 0 \\ \frac{t}{1-t}, & 0 < t < 1 \end{cases}$$

\therefore It is continuous and $f(-1^+) = -\infty, f(1^-) = +\infty$

\therefore Range = $(-\infty, +\infty) = \mathbb{R}$

It is differentiable also,

$$f'(t) = \begin{cases} \frac{1}{(1+t)^2}, & -1 < t < 0 \\ \frac{1}{(1-t)^2}, & 0 < t < 1 \end{cases}$$

$\therefore f'(t) > 0 \forall -1 < t < 1$

$\therefore f$ is injective

65. If P_1P_2 and P_3P_4 are two focal chords of the parabola $y^2 = 4ax$ then the chords P_1P_3 and P_2P_4 intersect on the

(A) directrix of the parabola

(B) axis of the parabola

(C) latus-rectum of the parabola

(D) y-axis

Ans : (A)

Hint : Let $P_i(at_i^2, 2at_i)$, $i = 1, 2, 3, 4$

then, $t_1t_2 = t_3t_4 = -1$

equation of $P_1P_3 : (t_1 + t_3)y = 2x + 2at_1t_3$ (1)

$P_2P_4 : (t_2 + t_4)y = 2x + 2at_2t_4$ (2)

Putting $x = -a$ in equation (1) gives $y = \frac{2at_1t_3 - 2a}{t_1 + t_3}$

Putting $x = -a$ in equation (2) gives

$$y = \frac{2at_2t_4 - 2a}{t_2 + t_4} = \frac{\frac{2a}{t_1t_3} - 2a}{-\frac{1}{t_1} - \frac{1}{t_3}} = \frac{2a(1 - t_1t_3)}{-(t_1 + t_3)} = \frac{2a(t_1t_3 - 1)}{(t_1 + t_3)}$$

\therefore These lines meet at $\left(-a, \frac{2a(t_1t_3 - 1)}{t_1 + t_3}\right)$

CATEGORY - III (Q66 to Q75)

(Carry 2 marks each. One or more options are correct. No negative marks)

66. The line $y = x + 5$ touches

- (A) the parabola $y^2 = 20x$
- (B) the ellipse $9x^2 + 16y^2 = 144$
- (C) the hyperbola $\frac{x^2}{29} - \frac{y^2}{4} = 1$
- (D) the circle $x^2 + y^2 = 25$

Ans : (A, B, C are correct)

Hint : (A) $y^2 = 20x = 4(5)x \quad \therefore$ Tangent : $y = mx + \frac{a}{m}$ for $m = 1, a = 5$

$\therefore y = x + 5$ is a tangent to $y^2 = 20x$

(B) $9x^2 + 16y^2 = 144 \quad c^2 = a^2m^2 + b^2 \quad y = x + 5 \Rightarrow m = 1; c = 5$

$$\Rightarrow \frac{x^2}{16} + \frac{y^2}{9} = 1 \quad \therefore 5^2 = 16(1)^2 + 9 \Rightarrow \text{True}$$

$\therefore y = x + 5$ is a tangent to $9x^2 + 16y^2 = 144$

(C) $c^2 = a^2m^2 - b^2 \quad \frac{x^2}{29} - \frac{y^2}{4} = 1 \rightarrow a^2 = 29; b^2 = 4$

$$5^2 = 29(1)^2 - 4 \rightarrow \text{True}$$

$\therefore y = x + 5$ is a tangent

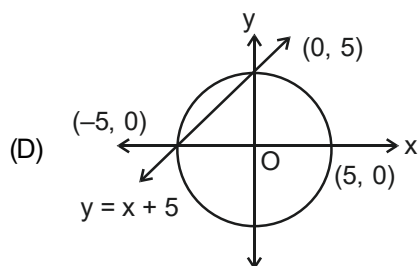

$\therefore y = x + 5$ is NOT tangent to $x^2 + y^2 = 25$

(A), (B), (C) are correct.

67. Let $p(x)$ be a polynomial with real co-efficients, $p(0) = 1$ and $p'(x) > 0$ for all $x \in \mathbb{R}$. Then

- (A) $p(x)$ has at least two real roots
- (B) $p(x)$ has only one positive real root
- (C) $p(x)$ may have negative real root
- (D) $p(x)$ has infinitely many real roots

Ans : (C)

Hint : $P(x) = 0$ has exactly one negative real root.

68. Twenty metres of wire is available to fence off a flower bed in the form of a circular sector. What must the radius of the circle be, if the area of the flower bed be greatest?

- (A) 10 m
- (B) 4 m
- (C) 5 m
- (D) 6 m

Ans : (C)

Hint : Let, radius = r , arc length = ℓ

$$2r + \ell = 20 \Rightarrow \ell = 20 - 2r$$

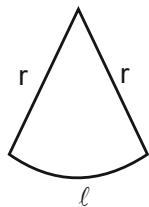

$$\Rightarrow A = \frac{1}{2}\ell r = \frac{1}{2}(20 - 2r)r \Rightarrow \frac{dA}{dr} = \frac{1}{2}(20 - 4r) = 0 \Rightarrow \boxed{r = 5} \therefore r = 5\text{m}$$

69. Let $f(x) = x^2 + x \sin x - \cos x$. Then

- (A) $f(x) = 0$ has at least one real root
- (B) $f(x) = 0$ has no real root
- (C) $f(x) = 0$ has at least one positive root
- (D) $f(x) = 0$ has at least one negative root

Ans : (A, C, D)

Hint : $f'(x) = 2x + x \cos x + \sin x + \sin x = 2(x + \sin x) + x \cos x$

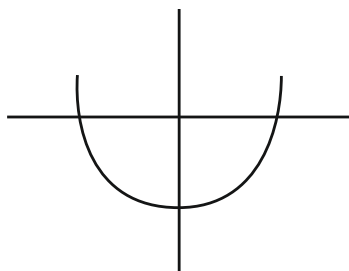

$$\Rightarrow f'(x) > 0 \quad \forall x > 0, \quad f'(x) < 0 \quad \forall x < 0 \Rightarrow f(0) = -1$$

70. From a balloon rising vertically with uniform velocity v ft/sec a piece of stone is let go. The height of the balloon above the ground when the stone reaches the ground after 4 sec is $[g = 32 \text{ ft/sec}^2]$

- (A) 220 ft
- (B) 240 ft
- (C) 256 ft
- (D) 260 ft

Ans : (C)

Hint : When stone is let go, its velocity = $-v$ (downwards)

Let, it was at a height h .

$$\therefore h = -vt + \frac{1}{2}gt^2$$