

Code - B



ANSWERS & HINTS
for
WBJEE - 2022
SUB : PHYSICS & CHEMISTRY

PHYSICS

CATEGORY - I (Q1 to Q30)

(Carry 1 mark each. Only one option is correct. Negative mark – ¼)

1. Two charges, each equal to $-q$ are kept at $(-a, 0)$ and $(a, 0)$. A charge q is placed at the origin. If q is given a small displacement along y direction, the force acting on q is proportional to

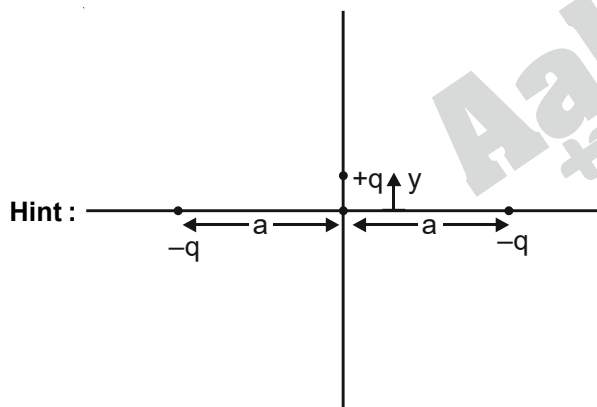
(A) y (B) $-y$ (C) $\frac{1}{y}$ (D) $-\frac{1}{y}$ **Ans : (B)**

$\vec{F} = +q$ (Electric field due to the two negative charges = \vec{E})

$$\vec{F} = +q \left[\frac{k(-2q)\vec{y}}{a^3} \right] \Rightarrow \vec{F} = -\frac{2kq^2y}{a^3} \Rightarrow \vec{F} \propto -\vec{y}$$

2. Consider a thermodynamic process where internal energy $U = AP^2V$ ($A = \text{constant}$). If the process is performed adiabatically, then

(A) $AP^2(V + 1) = \text{constant}$ (B) $(AP + 1)^2V = \text{constant}$ (C) $(AP + 1)V^2 = \text{constant}$ (D) $\frac{V}{(AP + 1)^2} = \text{constant}$ **Ans : (B)**

Hint : $U = AP^2V$

$$\frac{dU}{dV} = AP^2 + 2PAV \frac{dP}{dV} \quad [\text{For adiabatic process } dQ = 0, \quad dU = -dw = -PdV]$$

$$-\frac{PdV}{dV} = AP^2 + 2PAV \frac{dP}{dV}$$

$$-1 = AP + 2AV \frac{dP}{dV} \Rightarrow -1 - AP = 2AV \frac{dP}{dV}$$

$$-\int \frac{dV}{V} = \int \frac{2AdP}{AP+1}$$

$$-\ln V + C = \frac{2A}{A} \ln(AP+1)$$

$$C = \ln(AP+1)^2 + \ln V \Rightarrow \boxed{C = (AP+1)^2 V}$$

3. One mole of a diatomic ideal gas undergoes a process shown in P-V diagram. The total heat given to the gas ($\ln 2 = 0.7$) is

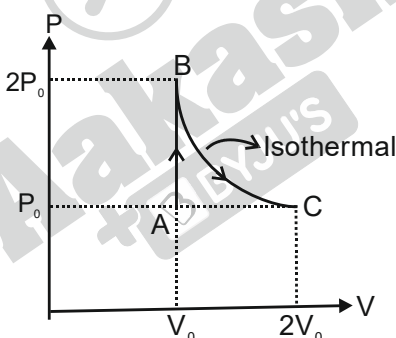

- (A) $2.5 P_0 V_0$ (B) $3.9 P_0 V_0$ (C) $1.1 P_0 V_0$ (D) $1.4 P_0 V_0$

Ans : (B)

Hint : For a Diatomic gas the total heat given is $\Delta Q_{AB} + \Delta Q_{BC}$

$$\Delta Q_{AB} \text{ (Isochoric Process)} = nC_V \Delta T$$

$$= \frac{P_f V_f - P_i V_i}{\gamma - 1} = \frac{2P_0 V_0 - P_0 V_0}{\frac{7}{5} - 1} = \frac{P_0 V_0}{\left(\frac{2}{5}\right)} = \frac{5}{2} P_0 V_0 = 2.5 P_0 V_0$$

$$\Delta Q_{BC} \text{ (Isothermal Process)}$$

$$Q_{BC} = nRT \ln \frac{V_f}{V_i} = PV \ln \frac{V_f}{V_i}$$

$$= 2P_0 \times V_0 \ln \left(\frac{2V_0}{V_0} \right) = 2P_0 V_0 \ln 2 = 1.4 P_0 V_0$$

$$\Rightarrow \boxed{\Delta Q_{\text{total}} = 3.9 P_0 V_0}$$

4. Consider two concentric conducting sphere of radii R and $2R$ respectively. The inner sphere is given a charge $+Q$. The other sphere is grounded. The potential at $r = \frac{3R}{2}$ is

- (A) $\frac{1}{4\pi\epsilon_0} \frac{Q}{6R}$ (B) 0 (C) $\frac{1}{4\pi\epsilon_0} \frac{2Q}{3R}$ (D) $\frac{1}{4\pi\epsilon_0} \frac{Q}{R}$

Ans : (A)

Hint :

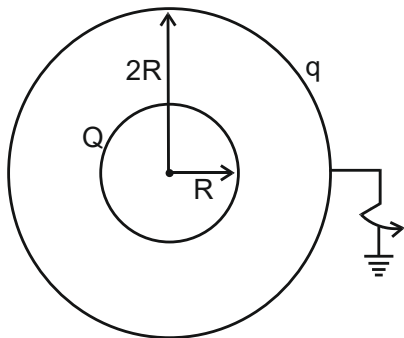

$q \rightarrow$ Charge appearing on shell of radius $2R$ after earthing

Calculating q $V_{\text{outer shell}} = \frac{KQ}{2R} + \frac{Kq}{2R} = 0$ $q = -Q$

Calculating potential at $r = \frac{3R}{2}$

$$V_{\text{inner shell}} + V_{\text{outer shell}} = \frac{KQ}{r} + \frac{Kq}{2R} = \frac{KQ}{\frac{3R}{2}} + \frac{K(-Q)}{2R} = \frac{KQ}{6R} = \frac{1}{4\pi\epsilon_0} \frac{Q}{6R}$$

5.

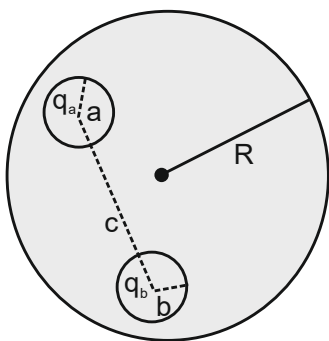

A neutral conducting solid sphere of radius R has two spherical cavities of radius a and b as shown in the figure. Centre to centre distance between two cavities is c . q_a and q_b charges are placed at the centres of cavities respectively. The force between q_a and q_b is

- (A) $\frac{1}{4\pi\epsilon_0} \frac{q_a q_b}{c^2}$ (B) $\frac{1}{4\pi\epsilon_0} q_a q_b \left(\frac{1}{a^2} + \frac{1}{b^2} \right)$
 (C) zero (D) insufficient data

Ans : (A)

Hint : Considering only interaction between charge q_a and q_b .

6. The electric potential for an electric field directed parallel to X-axis is shown in the figure. Choose the correct plot of electric field strength.

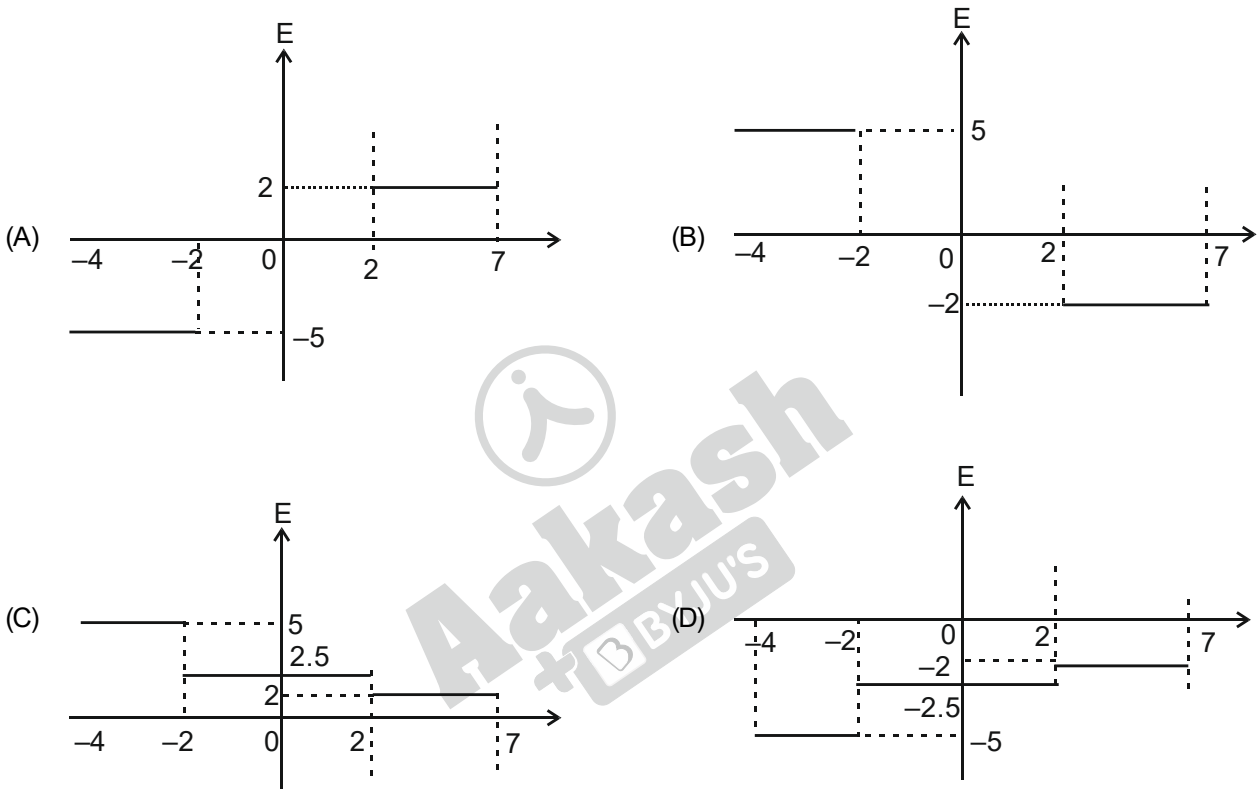
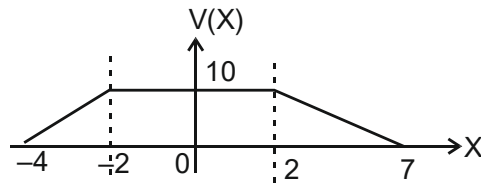

Ans : (A)

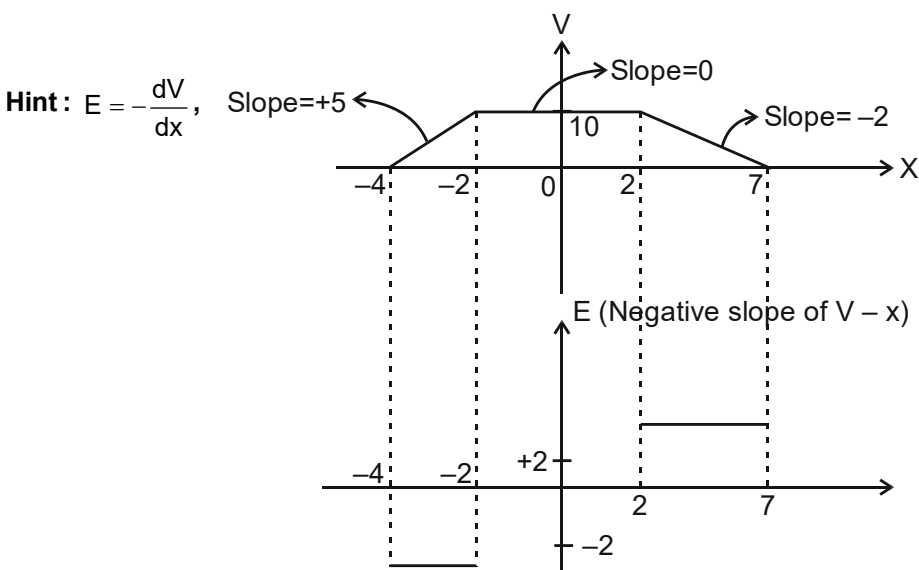

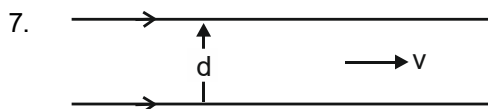

Two infinite line-charges parallel to each other are moving with a constant velocity v in the same direction as shown in the figure. The separation between two line-charges is d . The magnetic attraction balances the electric repulsion when, [c = speed of light in free space]

- (A) $v = \sqrt{2}c$ (B) $v = \frac{c}{\sqrt{2}}$ (C) $v = c$ (D) $v = \frac{c}{2}$

Ans : (C)

Hint : $F_E = q_2 E_1 = \lambda_2 \ell \frac{2k\lambda_1}{d}$

$$F_B = \frac{\mu_0 i_1 i_2 \ell}{2\pi d} = \frac{\mu_0 \lambda_1 V \lambda_2 V}{2\pi d} \times \ell$$

$$F_E = F_B$$

$$\Rightarrow \frac{2k\lambda_1 \lambda_2 \ell}{d} = \frac{\mu_0 \lambda_1 \lambda_2 V^2 \ell}{2\pi d}$$

$$\Rightarrow \frac{2\lambda_1 \lambda_2 \ell}{4\pi\epsilon_0} = \frac{\mu_0 \lambda_1 \lambda_2 V^2 \ell}{2\pi}$$

$$V^2 = \frac{1}{\mu_0 \epsilon_0} = c^2 \Rightarrow \boxed{V = c}$$

8. In a closed circuit there is only a coil of inductance L and resistance 100Ω . The coil is situated in a uniform magnetic field. All on a sudden, the magnetic flux linked with the circuit changes by 5 Weber. What amount of charge will flow in the circuit as a result?

- (A) 500 C (B) 0.05 C
(C) 20 C (D) Value of L is to be known to find the charge flown

Ans : (C)

Hint : $\text{Emf} = -\frac{d\phi}{dt}$ (Faraday's Law)

$$i_{\text{induced}} = \frac{\text{Emf}}{R} = -\frac{d\phi}{dt} \times \frac{1}{R}$$

$$\Rightarrow \frac{dq}{dt} = -\frac{1}{R} \frac{d\phi}{dt} \Rightarrow dq = -\frac{d\phi}{R} \Rightarrow \int dq = -\int \frac{d\phi}{R}$$

$$\Rightarrow q_{\text{flown}} = \frac{\phi_i - \phi_f}{R} = \frac{5 \text{ weber}}{100} = 0.05 \text{ C.}$$

9. An electron revolves around the nucleus in a circular path with angular momentum \vec{L} . A uniform magnetic field \vec{B} is applied perpendicular to the plane of its orbit. If the electron experiences a torque $\vec{\tau}$, then

- (A) $\vec{\tau} \parallel \vec{L}$
- (B) $\vec{\tau}$ is anti-parallel to \vec{L}
- (C) $\vec{\tau} \cdot \vec{L} = 0$
- (D) Angle between $\vec{\tau}$ and \vec{L} is 45°

Ans : (C)

Hint :

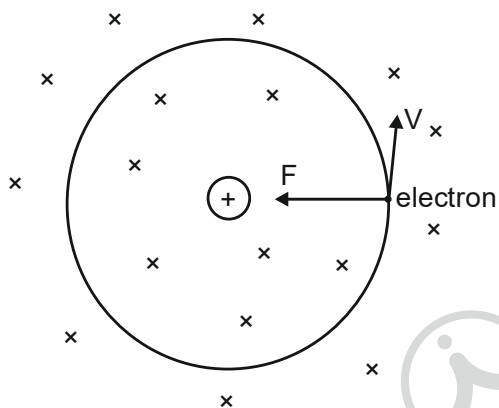

$$\vec{\tau} = 0 \Rightarrow \vec{\tau} \cdot \vec{L} = 0$$

10. A straight wire is placed in a magnetic field that varies with distance x from origin as $\vec{B} = B_0 \left(2 - \frac{x}{a} \right) \hat{k}$. Ends of wire are at $(a, 0)$ and $(2a, 0)$ and it carries a current I . If force on wire is $\vec{F} = IB_0 \left(\frac{ka}{2} \right) \hat{j}$, then value of k is

- (A) 1
- (B) 5
- (C) -1
- (D) $\frac{1}{2}$

Ans : (C)

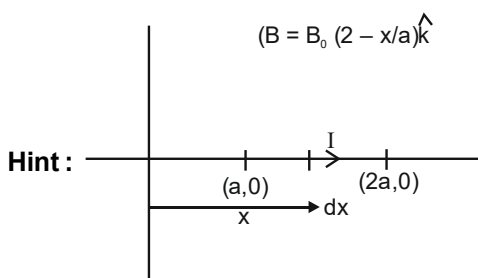

Hint :

$$d\vec{F} = I d\vec{x} \times \vec{B} = I dx \hat{i} \times B \hat{k} = I dx B (-\hat{j})$$

$$\int dF = \int_a^{2a} I dx B_0 \left(2 - \frac{x}{a} \right) (-\hat{j})$$

$$\begin{aligned}
 F &= IB_0 \int_a^{2a} \left(2 - \frac{x}{a}\right) dx (-\hat{j}) \\
 &= IB_0 \left[2x - \frac{x^2}{2a}\right]_a^{2a} (-\hat{j}) \\
 &= IB_0 \left[\left(2 \times 2a - \frac{(2a)^2}{2a}\right) - \left(2a - \frac{a^2}{2a}\right)\right] (-\hat{j}) \\
 &= IB_0 \left[(4a - 2a) - \left(\frac{3a}{2}\right)\right] (-\hat{j}) \\
 &= IB_0 \left[2a - \frac{3a}{2}\right] (-\hat{j}) \\
 &= IB_0 \left[\frac{a}{2}\right] (-\hat{j})
 \end{aligned}$$

Comparing F with $IB_0 \left[\frac{ka}{2}\right] \hat{j}$, we get $k = -1$

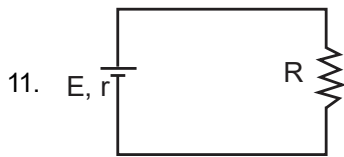

A battery of emf E and internal resistance r is connected with an external resistance R as shown in the figure. The battery will act as a constant voltage source if

- (A) $r \ll R$ (B) $r \gg R$
 (C) $r = R$ (D) It will never act as a constant voltage source

Ans : (A)

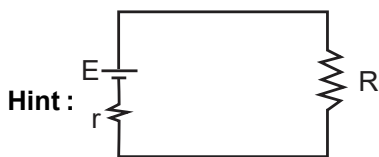

$$V_R = \frac{E}{(R+r)} \times R, \quad V_R = \frac{E}{(1+r/R)}$$

$$r \ll R, \quad V_R \approx E$$

12. When an AC source of emf E with frequency $\omega = 100 \text{ Hz}$ is connected across a circuit, the phase difference between E and current I in the circuit is observed to be $\frac{\pi}{4}$ as shown in the figure. If the circuit consist of only RC or RL in series, then

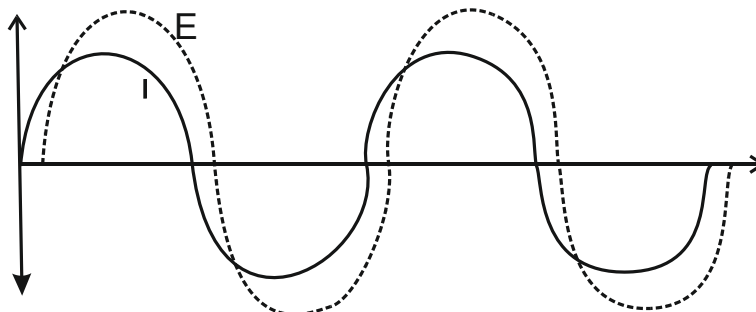

- (A) $R = 1 \text{ k}\Omega, C = 5 \mu\text{F}$ (B) $R = 1 \text{ k}\Omega, L = 10 \text{ H}$
 (C) $R = 1 \text{ k}\Omega, L = 1 \text{ H}$ (D) $R = 1 \text{ k}\Omega, C = 10 \mu\text{F}$

Ans : (D)

Hint : Since supply voltage lags the current By $(\phi = \pi / 4)$

$$\tan \phi = \frac{X_c}{R} = 1, X_c = R \dots\dots (1)$$

$$X_c = \frac{1}{\omega c} = \frac{1}{100 \times 10 \times 10^{-6}} = 1 \text{ k}\Omega = R$$

13. The human eye has an approximate angular resolution of $\theta = 5.8 \times 10^{-4} \text{ rad}$ and typical photo printer prints a minimum of 300 dip (dots per inch, 1 inch = 2.54 cm). At what minimal distance d should a printed page be held so that one does not see the individual dots ?
 (A) 20.32 cm (B) 29.50 cm (C) 14.59 cm (D) 6.85 cm

Ans : (C)

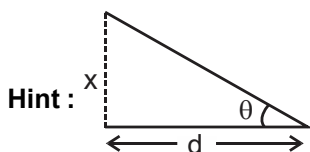

$$\theta = \frac{x}{d}$$

$$5.8 \times 10^{-4} = \frac{2.54}{300} \times \frac{1}{d}$$

$$d = 14.59 \text{ cm}$$

14. If the kinetic energies of an electron, an alpha particle and a proton having same de-Broglie wavelength are ϵ_1, ϵ_2 and ϵ_3 respectively, then
 (A) $\epsilon_1 > \epsilon_3 > \epsilon_2$ (B) $\epsilon_1 = \epsilon_2 = \epsilon_3$
 (C) $\epsilon_1 < \epsilon_3 < \epsilon_2$ (D) $\epsilon_1 > \epsilon_2 > \epsilon_3$

Ans : (A)

Hint : $\lambda = \frac{h}{\sqrt{2mk}}$, $\sqrt{mk} = \text{const}$

$k \propto \frac{1}{m}$, $\epsilon_1 > \epsilon_3 > \epsilon_2$

15. In a Young's double slit experiment, the intensity of light at a point on the screen where the path difference between the interfering waves is λ , (λ being the wavelength of light used) is I . The intensity at a point where the path difference is $\frac{\lambda}{4}$ will be (assume two waves have same amplitude)

- (A) zero (B) I (C) $\frac{I}{2}$ (D) $\frac{I}{4}$

Ans : (C)

Hint : $I' = I \cos^2 \phi / 2$

$\phi = \frac{2\pi}{\lambda} \Delta x$, $\phi = \frac{2\pi}{\lambda} \cdot \frac{\lambda}{4} = \frac{\pi}{2}$

$\frac{\phi}{2} = \frac{\lambda}{4}$, $I' = I \cos^2 \frac{\pi}{4} = \frac{I}{2}$

16. In Young's double slit experiment with a monochromatic light, maximum intensity is 4 times the minimum intensity in the interference pattern. What is the ratio of the intensities of the two interfering waves ?

- (A) 1/9 (B) 1/3 (C) 1/16 (D) 1/2

Ans : (A)

Hint : $(\sqrt{I_1} + \sqrt{I_2})^2 = 4(\sqrt{I_1} - \sqrt{I_2})^2$

$\sqrt{I_1} + \sqrt{I_2} = 2(\sqrt{I_1} - \sqrt{I_2})$, $3\sqrt{I_2} = \sqrt{I_1}$, $\frac{I_2}{I_1} = \frac{1}{9}$

17. The expression $\bar{A}(A+B) + (B+AA)(A+\bar{B})$ simplifies to

- (A) $A+B$ (B) AB (C) $\overline{A+B}$ (D) $\bar{A} + \bar{B}$

Ans : (A)

Hint : $\bar{A}(A+B) + (B+AA)(A+\bar{B})$

$= \bar{A}A + \bar{A}B + (B+A)(A+\bar{B})$

$= 0 + \bar{A}B + AB + A + B\bar{B} + A\bar{B}$

$= (\bar{A}+A)B + A + 0 + A\bar{B}$

$= 1.B + A(1+\bar{B})$

$= A+B$

18. Suppose in a hypothetical world the angular momentum is quantized to be even integral multiples of $\frac{h}{2\pi}$. The largest possible wavelength emitted by hydrogen atoms in visible range in a world according to Bohr's model will be,

(Consider $hc = 1242 \text{ Mev-fm}$)

- (A) 153 nm (B) 409 nm (C) 121 nm (D) 487 nm

Ans : (D)

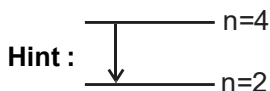

$$\frac{1}{\lambda} = R \left[\frac{1}{(2)^2} - \frac{1}{(4)^2} \right]$$

$$\frac{1}{\lambda} = R \left[\frac{3}{16} \right], \quad \lambda = \frac{912 \times 16}{3} = 4864 \text{ \AA}$$

$$\lambda \approx 487 \text{ nm}$$

19. A Zener diode having break down voltage $V_z = 6V$ is used in a voltage regulator circuit as shown in the figure. The minimum current required to pass through the Zener to act as a voltage regulator is 10 mA and maximum allowed current through Zener is 40 mA. The maximum value of R_s for Zener to act as a voltage regulator is

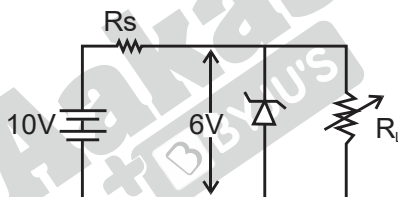

- (A) 100 Ω (B) 400 Ω (C) 0.4 Ω (D) 950 Ω

Ans : (B)

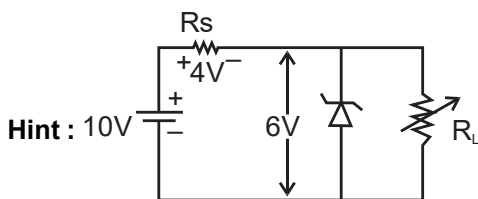

Minimum current = 10 mA ($I_L = 0$) $R_s = \frac{V}{I} = \frac{4V}{10\text{mA}} = 400\Omega$

20. The Entropy (S) of a black hole can be written as $S = \beta k_B A$, where k_B is the Boltzmann constant and A is the area of the black hole. Then β has dimension of

- (A) L^2 (B) ML^2T^{-1} (C) L^{-2} (D) dimensionless

Ans : (C)

Hint : $S = \beta K_p A$

$$\frac{[ML^2T^{-2}]}{[\theta]} = [\beta] \left[\frac{ML^2T^{-2}}{\theta} \right] [L^2] \quad [\beta] = [L^{-2}]$$

21. Given : The percentage error in the measurements of A, B, C and D are respectively, 4%, 2%, 3% and 1%. The relative

error in $Z = \frac{A^4 B^{\frac{1}{3}}}{CD^{\frac{1}{2}}}$ is

(A) $\frac{127}{2} \%$

(B) $\frac{127}{5} \%$

(C) $\frac{127}{6} \%$

(D) $\frac{127}{7} \%$

Ans : (C)

Hint : $Z = \frac{A^4 B^{\frac{1}{3}}}{CD^{\frac{1}{2}}} = \frac{\Delta Z}{Z} = 4 \frac{\Delta A}{A} + \frac{1}{3} \frac{\Delta B}{B} + \frac{\Delta C}{C} + \frac{3}{2} \frac{\Delta D}{D}$

$$= 4 \times 4\% + \frac{1}{3} \times 2\% + 3\% + \frac{3}{2} \times 1\% = \left(16 + \frac{2}{3} + 3 + \frac{3}{2} \right) \%$$

$$= \left(\frac{127}{6} \right) \%$$

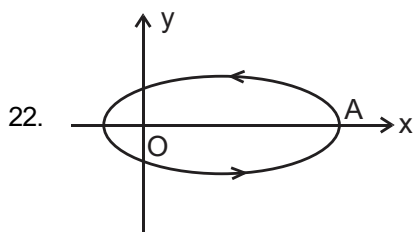

A particle is moving in an elliptical orbit as shown in figure. If \vec{p} , \vec{L} and \vec{r} denote the linear momentum, angular momentum and position vector of the particle (from focus O) respectively at a point A, then the direction of $\vec{\alpha} = \vec{p} \times \vec{L}$ is along

(A) +ve x axis

(B) -ve x axis

(C) +ve y axis

(D) -ve y axis

Ans : (A)

Hint : $\vec{\alpha} = \vec{p} \times \vec{L}$ \vec{L} is along Z-axis

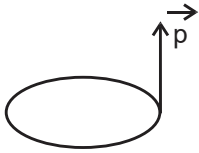

So, $\vec{p} \times \vec{L}$ is along (+)ve x-axis

23. The kinetic energy (E_k) of a particle moving along X-axis varies with its position (X) as shown in the figure. The force acting on the particle at $X = 10$ m is

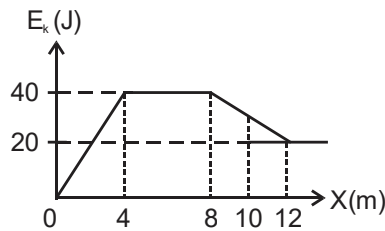

- (A) $5 \hat{i}$ N (B) 0 N (C) $97.5 \hat{i}$ N (D) $-5 \hat{i}$ N

Ans : (D)

Hint : $\frac{dk}{dx} = \frac{d\left(\frac{1}{2}mv^2\right)}{dx} = \frac{1}{2}m \cdot 2v \frac{dv}{dx} = ma = F$

So, Force is slope at $x = 10$ m $F = -\frac{20}{4} = -5 \hat{i}$

24. A body of mass m is thrown vertically upward with speed $\sqrt{3} v_e$, where v_e is the escape velocity of a body from earth surface. The final velocity of the body is

- (A) 0 (B) $2 v_e$ (C) $\sqrt{3} v_e$ (D) $\sqrt{2} v_e$

Ans : (D)

Hint : $-\frac{GMm}{R} + \frac{1}{2}m(\sqrt{3}v_e)^2 = 0 + \frac{1}{2}mv^2$, $v = \sqrt{2}v_e$

25. A particle is subjected to two simple harmonic motions in the same direction having equal amplitudes and equal frequency. If the resultant amplitude is equal to the amplitude of the individual motion, the phase difference (δ) between the two motions is

- (A) $\delta = \frac{\pi}{3}$ (B) $\delta = \frac{2\pi}{3}$ (C) $\delta = \pi$ (D) $\delta = \frac{\pi}{2}$

Ans : (B)

Hint : $A_{res}^2 = A_1^2 + A_2^2 + 2A_1A_2 \cos \delta$ $A^2 = A^2 + A^2 + 2A^2 \cos \delta$, $\cos \delta = -\frac{1}{2}$ $\delta = 120^\circ$

26. A body of mass m is thrown with velocity u from the origin of a co-ordinate axes at an angle θ with the horizon. The magnitude of the angular momentum of the particle about the origin at time t when it is at the maximum height of the trajectory is proportional to

- (A) u (B) u^2 (C) u^3 (D) independent of u

Ans : (C)

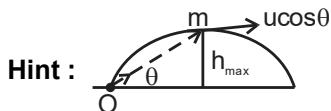

$$\vec{L} = m u \cos \theta h_{\max} = m u \cos \theta \frac{u^2 \sin^2 \theta}{2g} \Rightarrow L = \frac{m u^3 \sin^2 \theta \cos \theta}{2g} \quad L \propto u^3$$

27. Three particles, each of mass ' m ' grams situated at the vertices of an equilateral ΔABC of side ' a ' cm (as shown in the figure). The moment of inertia of the system about a line AX perpendicular to AB and in the plane of ABC in $g\text{-cm}^2$ units will be

- (A) $2ma^2$ (B) $\frac{3}{2}ma^2$ (C) $\frac{3}{4}ma^2$ (D) $\frac{5}{4}ma^2$

Ans : (D)

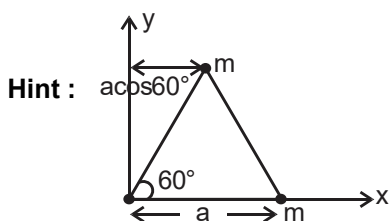

$$I = ma^2 + m(a \cos 60^\circ)^2 = ma^2 + \frac{ma^2}{4} = \frac{5ma^2}{4}$$

28. Certain amount of an ideal gas is taken from its initial state 1 to final state 4 through the paths $1 \rightarrow 2 \rightarrow 3 \rightarrow 4$ as shown in figure. AB, CD, EF are all isotherms. If v_p is the most probable speed of the molecules, then

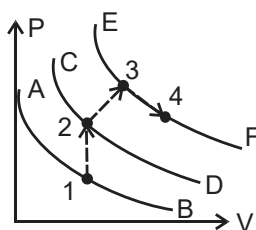

- (A) v_p at 3 = v_p at 4 > v_p at 2 > v_p at 1
 (B) v_p at 3 > v_p at 1 > v_p at 2 > v_p at 4
 (C) v_p at 3 > v_p at 2 > v_p at 4 > v_p at 1
 (D) v_p at 2 = v_p at 3 > v_p at 1 > v_p at 4

Ans : (A)

Hint : $v_p \propto \sqrt{T}$

29. If a string, suspended from the ceiling is given a downward force F_1 , its length becomes L_1 , its length is L_2 , if the downward force is F_2 . What is its actual length ?

- (A) $\frac{L_1 + L_2}{2}$ (B) $\sqrt{L_1 L_2}$ (C) $\frac{F_2 K_1 + F_1 K_2}{F_2 + F_1}$ (D) $\frac{F_2 K_1 - F_1 K_2}{F_2 - F_1}$

Ans : (D)

Hint : $(L_1 - L) = \frac{F_1 L}{Ay}$; $L_2 - L = \frac{F_2 L}{Ay}$

$$\Rightarrow \frac{L_1 - L}{L_2 - L} = \frac{F_1}{F_2} \Rightarrow F_2 L_1 - F_2 L = F_1 L_2 - F_1 L \Rightarrow L = \frac{F_2 L_1 - F_1 L_2}{F_2 - F_1}$$

30. 27 drops of mercury coalesce to form a bigger drop. What is the relative increase in surface energy ?

- (A) $\frac{3}{2}$ (B) $\frac{2}{3}$ (C) $-\frac{2}{3}$ (D) 8

Ans : (C)

Hint : Let the initial radius r and final radius R . $\frac{4}{3}\pi R^3 = 27 \times \frac{4}{3}\pi r^3 \Rightarrow R = 3r$

$$U_i = (S \ 4\pi r^2) \times 27 \quad U_f = S \ 4\pi R^2$$

$$\text{Relative increase} = \left(\frac{U_f - U_i}{U_i} \right) = \frac{9 - 27}{27} = -\frac{18}{27} = -\frac{2}{3}$$

Category II (Q31 to Q 35)

(Carry 2 marks each. Only one option is correct. Negative marks – 1/2)

31. Three concentric metallic shells A, B and C of radii a , b and c ($a < b < c$) have surface charge densities $+\sigma$, $-\sigma$ and $+\sigma$ respectively. The potential of shell B is

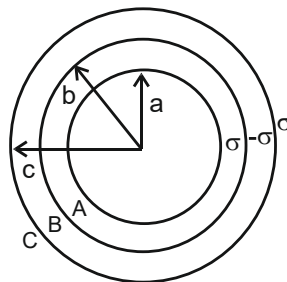

- (A) $(a + b + c) \frac{\sigma}{\epsilon_0}$ (B) $\frac{\sigma c}{\epsilon_0}$ (C) $\left(\frac{a^2}{c} - \frac{b^2}{c} + c \right) \frac{\sigma}{\epsilon_0}$ (D) $\left(\frac{a^2}{b} - b + c \right) \frac{\sigma}{\epsilon_0}$

Ans : (D)

Hint : $V_b = V_{A,b} + V_{B,b} + V_{C,b}$

$$= \frac{K\sigma 4\pi a^2}{b} - \frac{K\sigma 4\pi b^2}{b} + \frac{K\sigma 4\pi c^2}{c}$$

$$= \frac{\sigma}{\epsilon_0} \left(\frac{a^2}{b} - b + c \right)$$

32. A horizontal semi-circular wire of radius r is connected to a battery through two similar springs X and Y to an electric cell, which sends current I through it. A vertically downward uniform magnetic field B is applied on the wire, as shown in the figure. What is the force acting on each spring?

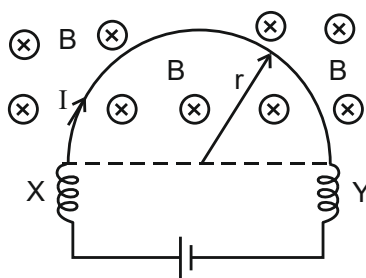

- (A) $2\pi BI$ (B) $\frac{1}{2} \pi r BI$ (C) BIr (D) $2BIr$

Ans : (C)

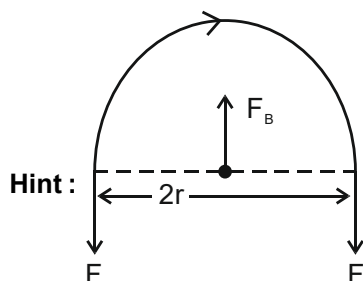

$$F_B = i \times 2r \times B$$

$$2F = F_B$$

$$F = irB$$

33. Find the equivalent capacitance between A and B of the following arrangement :

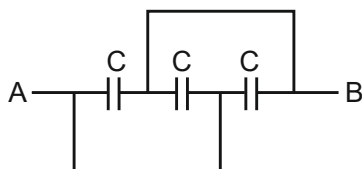

- (A) C (B) $3C$ (C) $\frac{2C}{3}$ (D) $\frac{3C}{2}$

Ans : (B)

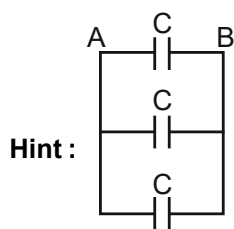

$$C_{\text{net}} = C + C + C = 3C$$

34. A golf ball of mass 50 gm placed on a tee, is struck by a golf-club. The speed of the golf ball as it leaves the tee is 100 m/s, the time of contact on the ball is 0.02 s. If the force decreases to zero linearly with time, then the force at the beginning of the contact is

- (A) 100 N (B) 200 N (C) 250 N (D) 500 N

Ans : (D)

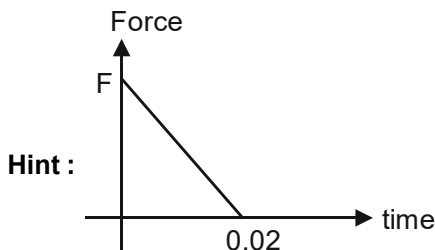

Impulse = Area under F-t graph = change in linear momentum

$$= \frac{1}{2} \times F \times 0.02 = \frac{50}{1000} (100 - 0) \Rightarrow F = 500 \text{ N}$$

35. One mole of an ideal monoatomic gas expands along the polytrope $PV^3 = \text{constant}$ from V_1 to V_2 at a constant pressure P_1 . The temperature during the process is such that molar specific heat $C_v = \frac{3R}{2}$. The total heat absorbed during the process can be expressed as

- (A) $P_1V_1\left(\frac{V_1^2}{V_2^2} + 1\right)$ (B) $P_1V_1\left(\frac{V_1^2}{V_2^2} - 1\right)$ (C) $P_1V_1\left(\frac{V_1^3}{V_2^2} - 1\right)$ (D) $P_1V_1\left(\frac{V_1}{V_2^2} - 1\right)$

Ans : (B)

Hint : Assuming P_1 as initial pressure.

$$PV^3 = \text{constant}$$

$$n = 3$$

$$C = C_v + \frac{R}{1-n} = \frac{3R}{2} + \frac{R}{1-3} = R$$

$$T_i = \frac{P_1V_1}{R}$$

$$P_2V_2^3 = P_1V_1^3$$

$$P_2 = P_1 \times \left(\frac{V_1}{V_2}\right)^3$$

$$T_2 = \frac{P_2V_2}{R} = \frac{P_1}{R} \times \left(\frac{V_1}{V_2}\right)^3 \times V_2 = \frac{P_1V_1^3}{RV_2^2}$$

$$Q = nC\Delta T$$

$$= 1 \times R \times \left(\frac{P_1V_1^3}{RV_2^2} - \frac{P_1V_1}{R}\right)$$

$$Q = P_1V_1\left(\frac{V_1^2}{V_2^2} - 1\right)$$

Category III (Q36 to Q40)

(Carry 2 marks each. One or more options are correct. No negative marks)

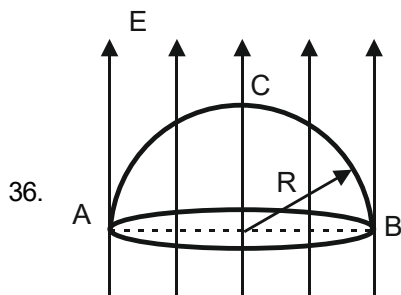

A hemisphere of radius R is placed in a uniform electric field E so that its axis is parallel to the field. Which of the following statement(s) is / are true ?

- (A) Flux through the curved surface of hemisphere is $\pi R^2 E$.
- (B) Flux through the circular surface of hemisphere is $\pi R^2 E$.
- (C) Total flux enclosed is zero
- (D) Work done in moving a point charge q from A to B via the path ACB depends upon R .

Ans : (A, C)

Hint : as $\phi_{in} = 0$, $\phi_{total} = 0$

$$\phi_{curved} + \phi_{flat} = 0$$

$$\phi_{flat} = -E \times \pi R^2$$

$$\therefore \phi_{curved} = E \times \pi R^2$$

Also $\Delta V = -\vec{E} \cdot \Delta \vec{r}$ for uniform electrified.

as $\vec{E} \perp \Delta \vec{r}$

$$\Delta V = 0$$

$$W = q\Delta V = 0$$

so work is independent of R in moving charge q from $A + B$

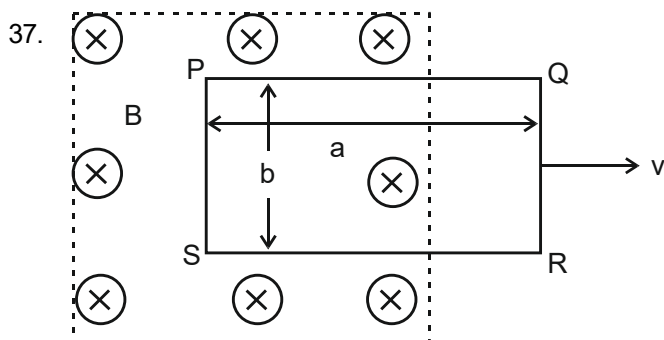

As shown in figure, a rectangular loop of length ' a ' and width ' b ' and made of a conducting material of uniform cross-section is kept in a horizontal plane where a uniform magnetic field of intensity B is acting vertically downward. Resistance per unit length of the loop is $\lambda \Omega/m$. If the loop is pulled with uniform velocity ' v ' in horizontal direction, which of the following statement is / are true ?

- (A) Current in the loop $I = \frac{Bbv}{\lambda(2b + 2a)}$
- (B) Current will be in clockwise direction, looking from the top.
- (C) $V_P - V_S = V_Q - V_R$, where V is the potential
- (D) There cannot be any induction in part SR.

Ans : (A, D)

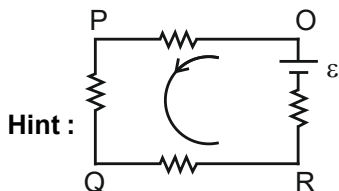

$$\varepsilon = B \times b \times v$$

$$i = \frac{\varepsilon}{R_{\text{total}}} = \frac{\varepsilon}{\lambda(2b + 2a)}$$

Current is anticlockwise

$$V_P - V_S \neq V_Q - V_R$$

Also SR, $\vec{\ell} \parallel \vec{v}$; So $\varepsilon = 0$

38. A sample of hydrogen atom in its ground state is radiated with photons of 10.2 eV energies. The radiation from the sample is absorbed by excited ionized He⁺. Then which of the following statement/s is / are true ?
- (A) He⁺ electron moves from n = 2 to n = 4
 - (B) In the He⁺ emission spectra, there will be 6 lines
 - (C) Smallest wavelength of He⁺ spectrum is obtained when transition taken place from n = 4 to n = 3
 - (D) He⁺ electron moves from n = 2 to n = 3

Ans : (A, C)

Hint : $E = 13.6 \times 2^2 \left(\frac{1}{n^2} - \frac{1}{m^2} \right)$

$$n = 2 \text{ to } m = 4$$

$$E = 13.6 \times 2^2 \times \left(\frac{1}{2^2} - \frac{1}{4^2} \right) = 10.2 \text{ eV}$$

So He⁺ electron can move from n = 2 to n = 4

$$\text{Number of spectral lines} = \frac{n(n-1)}{2} = \frac{4(4-1)}{2} = 6$$

Smallest wavelength correspond to n = 4 to n = 3 transition

39. A particle is moving in x – y plane according to $\vec{r} = b \cos \omega t \hat{i} + b \sin \omega t \hat{j}$. Where ω is constant. Which of the following statement(s) is / are true ?
- (A) $\frac{E}{\omega}$ is a constant where E is the total energy of the particle
 - (B) The trajectory of the particle in x – y plane is a circle

(C) In $a_x - a_y$ plane, trajectory of the particle is an ellipse (a_x, a_y denotes the components of acceleration)

(D) $\vec{a} = \omega^2 \vec{v}$

Ans : (A, B)

Hint : $\vec{r} = b \cos \omega t \mathbf{i} + b \sin \omega t \mathbf{j}$

$$\vec{v} = \frac{d\vec{r}}{dt} = -b\omega \sin \omega t \mathbf{i} + b\omega \cos \omega t \mathbf{j}$$

$$(\vec{v}) = \sqrt{b^2 \omega^2 \sin^2 \omega t + b^2 \omega^2 \cos^2 \omega t}$$

$$(\vec{v}) = b\omega \rightarrow \text{constant} \quad \therefore E = \frac{1}{2} m v^2 = \text{constant}$$

$$E = \frac{1}{2} m [b^2 \omega^2] \quad \Rightarrow \frac{E}{\omega} = \frac{1}{2} m b^2 \cdot \omega = \text{constant}$$

$$x = b \cos \omega t$$

$$y = b \sin \omega t$$

$$x^2 + y^2 = b^2 \rightarrow \text{equation of circle}$$

$$\therefore \vec{a} \perp \vec{v} \quad \text{So } \vec{a} \neq \omega^2 \vec{v}$$

40.

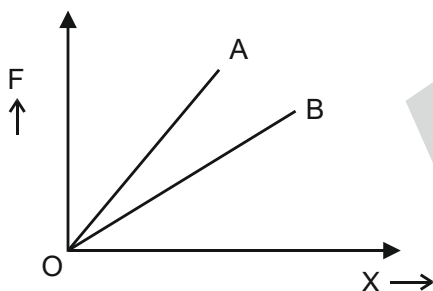

Two wires A and B of same length are made of same material. Load (F) vs. elongation (x) graph for these two wires is shown in the figure. Then which of the following statement(s) is / are true ?

- (A) The cross-section area of A is greater than that of B.
- (B) Young's modulus of A is greater than Young's modulus of B.
- (C) The cross-sectional area of B is greater than that of A.
- (D) Young's modulus of both A and B are same.

Ans : (A, D)

Hint : Same material have identical Young's Modulus.

For a given strain and Young's Modulus.

stress in same

$$\frac{F_A}{A_A} = \frac{F_B}{A_B} \quad \Rightarrow \quad \frac{F_A}{F_B} = \frac{A_A}{A_B}$$

$$\text{as } F_A > F_B, \quad A_A > A_B$$

CHEMISTRY

CATEGORY - I (Q41 to Q70)

(Carry 1 mark each. Only one option is correct. Negative marks $-\frac{1}{4}$)

41. Which one of the following is the correct set of four quantum numbers (n, l, m, s) ?

- (A) $\left(3, 0, -1, +\frac{1}{2}\right)$ (B) $\left(4, 3, -2, -\frac{1}{2}\right)$ (C) $\left(3, 1, -2, -\frac{1}{2}\right)$ (D) $\left(4, 2, -3, +\frac{1}{2}\right)$

Ans : (B)**Hint :** $n = 4, l = 0, 1, 2, 3$ For $l = 3, m = -3, -2, -1, 0, +1, +2, +3$ For $m = -2, s = -\frac{1}{2}$

42. Avogadro's law is valid for

- (A) all gases (B) ideal gas (C) Van der Waals gas (D) real gas

Ans : (B)**Hint :** Fact

43. A metal (M) forms two oxides. The ratio M:O (by weight) in the two oxides are 25:4 and 25:6. The minimum value of atomic of M is

- (A) 50 (B) 100 (C) 150 (D) 200

Ans : (B)**Hint :** Let two oxide beAs per question

$$\frac{2a}{16x} = \frac{25}{4} \text{ and } \frac{2a}{16y} = \frac{25}{6}$$

$$x = \frac{a}{50}, y = \frac{3a}{100} \text{ where } a = \text{atomic mass of Metal}$$

As x and y to be an integer,

If we take $a = 50$, then $x = 1, y = 1.5$ (not possible)If we take $a = 100$ then $x = 2, y = 3$ (possible) \therefore Minimum Atomic Mass = 100 u44. The de-Broglie wavelength (λ) for electron (e), proton (p) and He^{2+} ion (α) are in the following order. (Speed of e, p and α are the same)

- (A) $\alpha > p > e$ (B) $e > p > \alpha$ (C) $e > \alpha > p$ (D) $\alpha < p > e$

Ans : (B)**Hint :** $\lambda = \frac{h}{mv}$ \therefore speed are same

$$\therefore \lambda \propto \frac{1}{m}$$

$$\therefore \lambda_e > \lambda_p > \lambda_\alpha \text{ as } m_\alpha > m_p > m_e$$

45. 1 mL of water has 25 drops. Let N_0 be the Avogadro number. What is the number of molecules present in 1 drop of water? (Density of water = 1 g/mL)

- (A) $\frac{0.02}{9}N_0$ (B) $\frac{18}{25}N_0$ (C) $\frac{25}{18}N_0$ (D) $\frac{0.04}{25}N_0$

Ans : (A)

Hint : Volume of one drop = $\left(\frac{1}{25}\right)$ mL

$$\therefore \text{Mass of 1 drop} = V \times d$$

$$= \left(\frac{1}{25} \text{ mL}\right)(1 \text{ g/mL})$$

$$= \frac{1}{25} \text{ g}$$

$$\text{Number of moles of H}_2\text{O} = \frac{\text{Mass of water in one drop}}{\text{Molar mass of water}} = \frac{\frac{1}{25}}{18} = \frac{1}{25 \times 18}$$

$$\therefore \text{Number of H}_2\text{O Molecule} = \frac{1}{25 \times 18} N_0 = \frac{1}{50 \times 9} N_0 = \frac{0.02}{9} N_0$$

46. In Bohr model of atom, radius of hydrogen atom in ground state is r_1 and radius of He^+ ion in ground state is r_2 . Which of the following is correct?

- (A) $\frac{r_1}{r_2} = 4$ (B) $\frac{r_1}{r_2} = \frac{1}{2}$ (C) $\frac{r_2}{r_1} = \frac{1}{4}$ (D) $\frac{r_2}{r_1} = \frac{1}{2}$

Ans : (D)

Hint : $r_n = a_0 \times \frac{n^2}{Z}$

For H-atom

$$r_1 = a_0$$

Also, For He^+ ion

$$r_2 = a_0 \times \frac{1^2}{2} = \frac{r_1}{2}$$

$$\therefore \frac{r_2}{r_1} = \frac{1}{2}$$

47. The average speed of H_2 at $T_1\text{K}$ is equal to that of O_2 at $T_2\text{K}$. The ratio $T_1 : T_2$ is

- (A) 1 : 6 (B) 16 : 1 (C) 1 : 4 (D) 1 : 1

Ans : (*No option is correct)

Hint : $(C_{av})_{\text{H}_2} = (C_{av})_{\text{O}_2}$

$$\sqrt{\frac{8RT_1}{\pi M_{H_2}}} = \sqrt{\frac{8RT_2}{\pi M_{O_2}}}$$

$$\therefore \frac{T_1}{T_2} = \frac{M_{H_2}}{M_{O_2}} = \frac{2}{32} = \frac{1}{16}$$

* No option is correct.

48. A sample of $MgCO_3$ is dissolved in dil. HCl and the solution is neutralized with ammonia and buffered with NH_4Cl/NH_4OH . Disodium hydrogen phosphate reagent is added to the resulting solution. A white precipitate is formed. What is the formula of the precipitate ?

- (A) $Mg_3(PO_4)_2$ (B) $Mg(NH_4)PO_4$ (C) $MgHPO_4$ (D) $Mg_2P_2O_7$

Ans : (B)

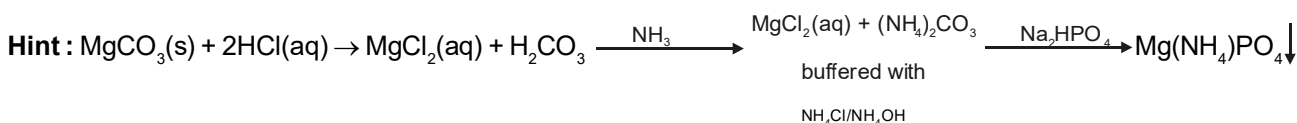

49. $XeF_2, NO_2, HCN, ClO_2, CO_2$.

Identify the non-linear molecule-pair from the above mentioned molecules.

- (A) XeF_2, ClO_2 (B) CO_2, NO_2 (C) HCN, NO_2 (D) ClO_2, NO_2

Ans : (D)

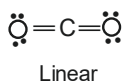
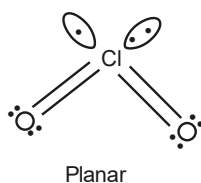
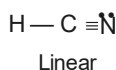
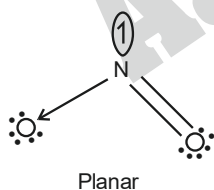
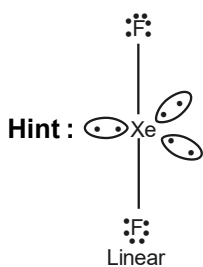

50. The number of atoms in body centred and face centred cubic unit cell respectively are

- (A) 2 and 4 (B) 4 and 3 (C) 1 and 2 (D) 4 and 6

Ans : (A)

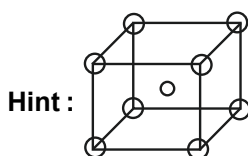

$$Z_{BCC} = \frac{1}{8} \times 8 + 1 = 2$$

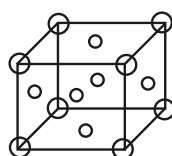

$$Z_{FCC} = \frac{1}{8} \times 8 + \frac{1}{2} \times 6 = 1 + 3 = 4$$

51. The number of unpaired electron in Mn^{2+} ion is

- (A) 2 (B) 3 (C) 5 (D) 6

Ans : (C)

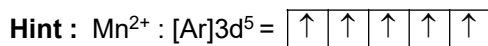

52. The correct bond order of B-F bond in BF_3 molecule is

- (A) 1 (B) $1\frac{1}{2}$ (C) 2 (D) $1\frac{1}{3}$

Ans : (D)

Hint : $B.O = \frac{2+1+1}{3} = 1\frac{1}{3}$

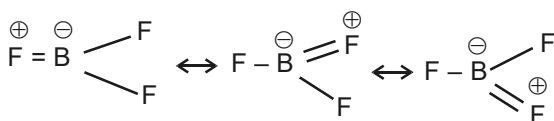

53. Sodium nitroprusside is

- (A) $Na_4[Fe(CN)_5NO_2]$ (B) $Na_2[Fe(CN)_5NO]$ (C) $Na_3[Fe(CN)_5NO]$ (D) $Na_4[Fe(CN)_5NO_3]$

Ans : (B)

Hint : Fact

54. Choose the correct statement for the $[Ni(CN)_4]^{2-}$ complex ion (Atomic no. of Ni = 28)

- (A) The complex is square planar and paramagnetic
 (B) The complex is tetrahedral and diamagnetic
 (C) The complex is square planar and diamagnetic
 (D) The complex is tetrahedral and paramagnetic

Ans : (C)

Hint : $[Ni(CN)_4]^{2-}$

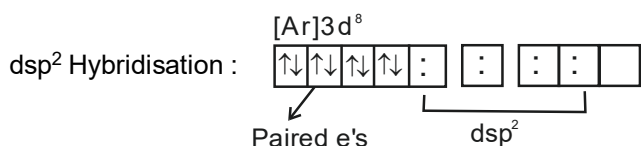
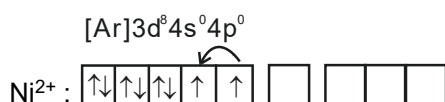

(Square planar complex and diamagnetic)

55. The boiling point of the water is higher than liquid HF. The reason is that

- (A) Hydrogen bonds are stronger in water
 (B) Hydrogen bonds are stronger in HF.
 (C) Hydrogen bonds are larger in number in HF
 (D) Hydrogen bonds are larger in number in water

Ans : (D)

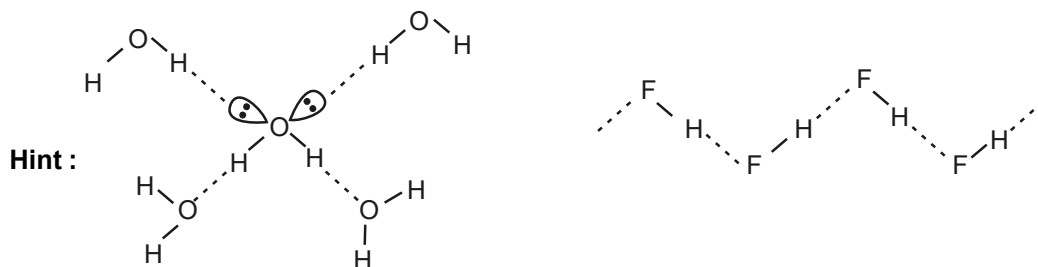

56. The metal-pair that can produce nascent hydrogen in alkaline medium is
 (A) Zn, Al (B) Fe, Ni (C) Al, Mg (D) Mg, Zn

Ans : (A)

Hint : Fact

57. Oxidation states of Cr in $K_2Cr_2O_7$ and CrO_5 are, respectively
 (A) +6, +5 (B) +6, +10 (C) +6, +6 (D) None of these

Ans : (C)

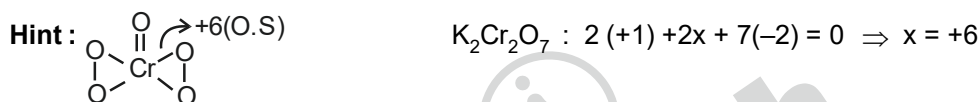

58. Which of the following is radioactive?
 (A) Hydrogen (B) Deuterium (C) Tritium (D) none

Ans : (C)

Hint : Fact

59. The correct order of acidity of the following hydra acids is
 (A) $HF > HCl > HBr > HI$ (B) $HF < HCl < HBr < HI$ (C) $HF < HCl > HBr > HI$ (D) $HF > HCl < HBr > HI$

Ans : (B)

Hint : $HI > HBr > HCl > HF$

Down the group acidic strength increases.

60. To a solution of colourless sodium salt, a solution of lead nitrate was added to have a white precipitate which dissolves in warm water and reprecipitates on cooling. Which of the following acid radical is present in the salt?
 (A) Cl^- (B) SO_4^{2-} (C) S^{2-} (D) NO_3^-

Ans : (A)

Hint : $2NaCl + Pb(NO_3)_2 \rightarrow PbCl_2(ppt) + 2NaNO_3$

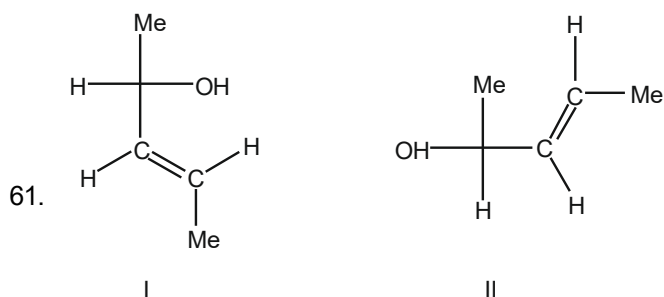

The correct relationship between molecules I and II is

- (A) Enantiomer (B) Homomer (C) Diastereomer (D) Constitutional isomer

Ans : (B)

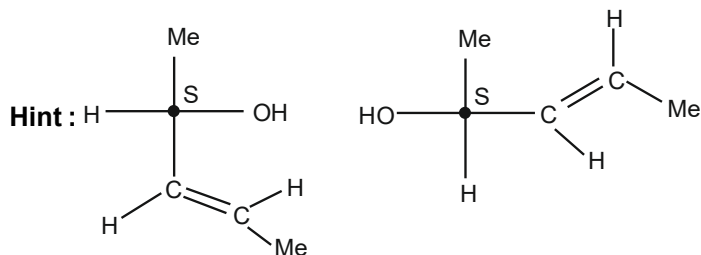

They are homomers

62. The correct order of relative stability for the given free radicals is

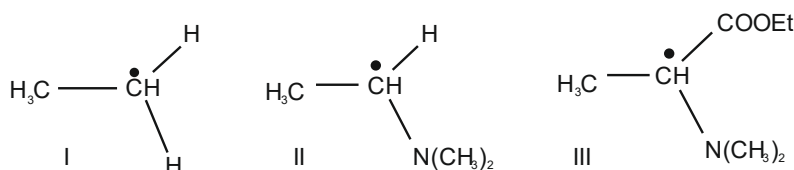

- (A) II > I > III (B) II > III > I (C) III > I > II (D) III > II > I

Ans : (D)*

Hint : III > II > I

Adjacent functional group appear to weaken C – H Bonds, hence making free radical more stable
 (* All the three are molecules - not radicals. We have assumed them as radicals)

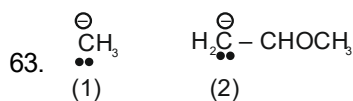

Hybridisation of the negative carbons in (1) and (2) are

- (A) sp^2 and sp^3 (B) sp^3 and sp^2 (C) both sp^2 (D) both sp^3

Ans : (B or D)

Hint : Original question is $\oplus \overset{\oplus}{\text{C}}\text{H}_3$ $\overset{\oplus}{\text{H}_2\text{C}} - \text{CHOCH}_3$ which is a misprint.
 (1) (2)

Probable structures are:

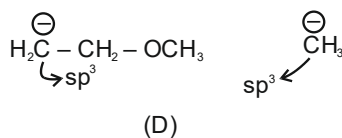

OR

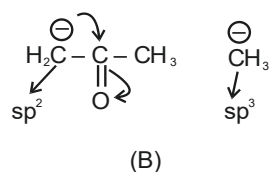

64. What is the correct order of acidity of salicylic acid, 4-hydroxybenzoic acid, and 2, 6-dihydroxybenzoic acid?

- (A) 2, 6-dihydroxybenzoic acid > salicylic acid > 4-hydroxybenzoic acid
 (B) 2, 6-dihydroxybenzoic acid > 4-hydroxybenzoic acid > salicylic acid
 (C) salicylic acid > 2, 6-dihydroxybenzoic acid > 4-hydroxybenzoic acid
 (D) salicylic acid > 4-hydroxybenzoic acid > 2, 6-dihydroxybenzoic acid

Ans : (A)

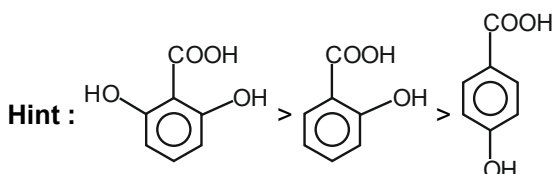

The conjugate base of 2, 6-dihydroxybenzoic acid is highly stabilised by H-bonding. The effect is lesser in salicylic acid.

65. The enol form in which ethyle-3-oxobutanoate exists is

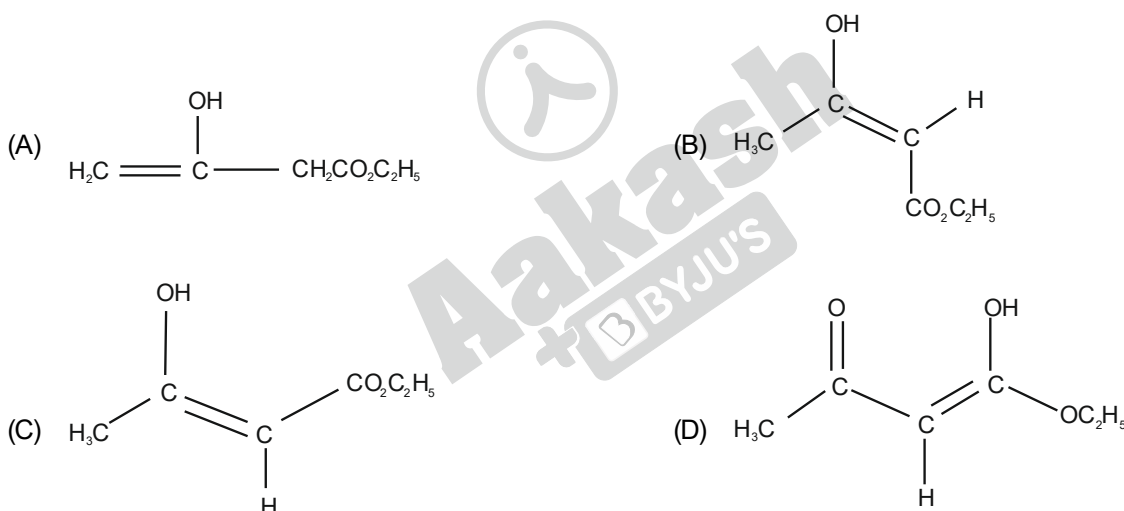

Ans : (C)

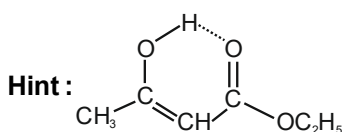

Stabilised by H-bonding and Ketonic group enolises relatively more than ester group.

66. How many monobrominated product(s) (including stereoisomers) would form in the free radical bromination of n-butane?

- (A) 2 (B) 1 (C) 3 (D) 4

Ans : (C)

Hint : Total = 3

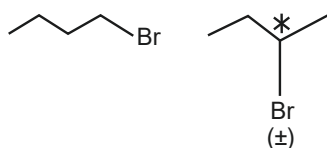

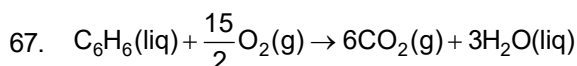

Benzene burns in oxygen according to the above equation. What is the volume of oxygen (at STP) needed for complete combustion of 39 gram of liquid benzene?

- (A) 11.2 litre (B) 22.4 litre (C) 84 litre (D) 168 litre

Ans : (C)

Hint : $n_{\text{C}_6\text{H}_6} = \frac{39}{78} = \frac{1}{2}$ mole

From Balanced equation,

$$n_{\text{C}_6\text{H}_6} = \frac{2}{15} n_{\text{O}_2}$$

$$\frac{1}{2} = \frac{2}{15} \times \frac{x\text{L}}{22.4\text{L}}$$

$$\therefore x = 84 \text{ L}$$

68. How much solid oxalic acid (Molecular weight 126) has to be weighed to prepare 100 mL exactly 0.1 (N) oxalic acid solution in water?

- (A) 1.26 g (B) 0.126 g (C) 0.63 g (D) 0.063 g

Ans : (C)

Hint : $n_{\text{eq}} = N \times V(\text{L})$

$$= (0.1) \left(\frac{100}{1000} \right) = 0.01$$

weight = no. of eq (n_{eq}) \times Equivalent mass = $0.01 \times \frac{126}{2} = 0.63\text{g}$

69. The major product of the following reaction is

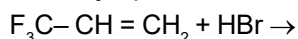

- (A) $\text{F}_3\text{C}-\text{CH}_2-\text{CH}_2\text{Br}$ (B) $\text{F}_3\text{C}-\text{CH}(\text{Br})-\text{CH}_3$ (C) $\text{F}_2\text{C}(\text{Br})-\text{CH}(\text{F})-\text{CH}_3$ (D) $\text{F}_2\text{CH}-\underset{\text{Br}}{\text{C}}\text{H}-\text{CH}_2\text{F}$

Ans : (A)

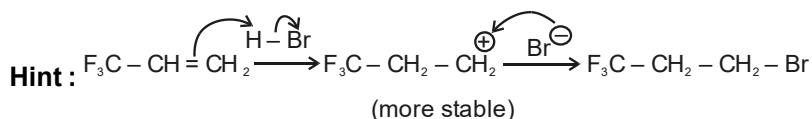

70. The correct order of relative stability of the given conformers of n-butane is

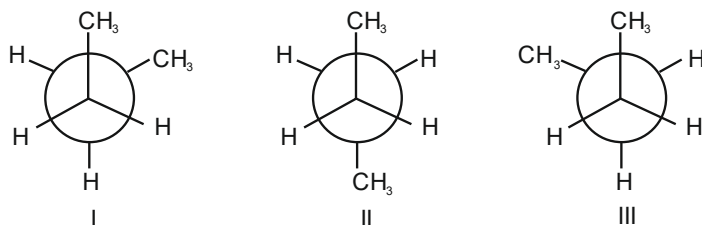

- (A) II > I = III (B) II > III > I (C) II > I > III (D) I = III > II

Ans : (A)

Hint : II > I = III

Anti form is more stable than Gauche form.

Category II (Q71 to Q 75)**(Carry 2 marks each. Only one option is correct. Negative marks : ½)**

71. Pick the correct statement.

- (A) Relative lowering of vapour pressure is independent of T.
 (B) Osmotic pressure always depends on the nature of solute.
 (C) Elevation of boiling point is independent of nature of the solvent.
 (D) Lowering of freezing point is proportional to the molar concentration of solute.

Ans : (A)**Hint :**

Relative lowering of vapour pressure is $\frac{\Delta P}{P^{\circ}}$, which is equal to mole fraction of solute which is independent of temperature.

72. Let $(C_{rms})_{H_2}$ is the r.m.s speed of H_2 at 150 K. At what temperature, the most probable speed of helium $[(C_{mp})_{He}]$ will be half of $(C_{rms})_{H_2}$?

- (A) 75 K (B) 112.5 K (C) 225 K (D) 900 K

Ans : (B)**Hint :**

$$C_{rms} = \sqrt{\frac{3RT}{M}} \quad C_{mp} = \sqrt{\frac{2RT}{M}}$$

$$\text{As per question } \frac{1}{2} \sqrt{\frac{3 \times R \times 150}{2}} = \sqrt{\frac{2RT}{4}}$$

$$T = 112.5 \text{ K}$$

73. The correct pair of electron affinity order is

- (A) $O > S, F > Cl$ (B) $O < S, Cl > F$ (C) $S > O, F > Cl$ (D) $S < O, Cl > F$

Ans : (B)**Hint :**

Second period elements of p-block have lower values of electron affinity than expected due to unusually smaller size.

74. The product of the following reaction is :

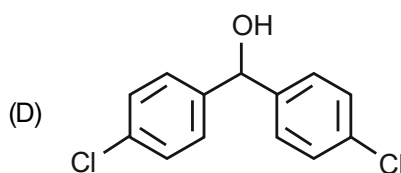
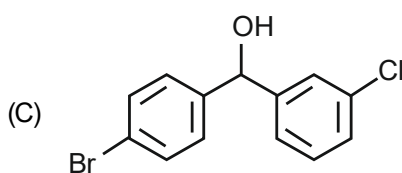
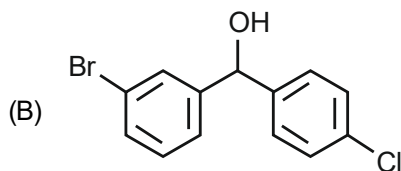
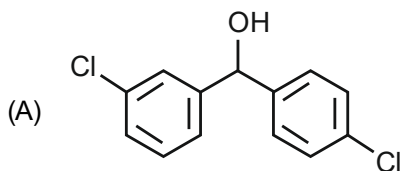
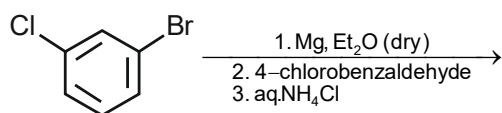

Ans : (A)

Hint :

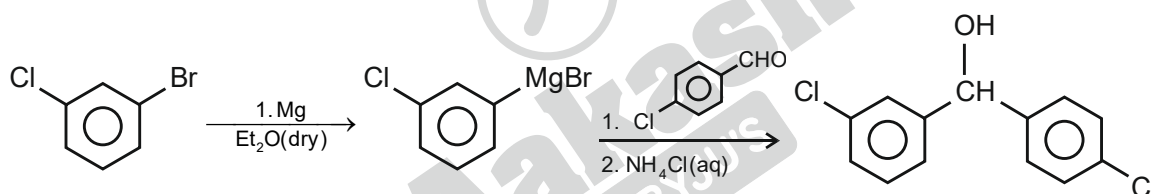

75. The product of the following hydrogenation reaction is :

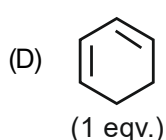
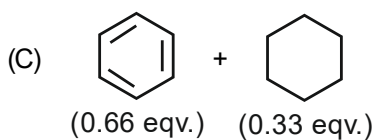
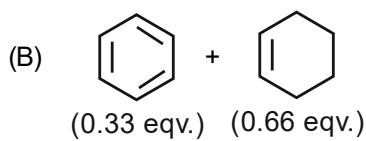
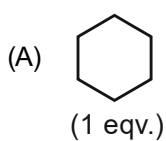
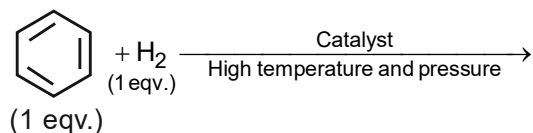

Ans : (C)

Hint :

The double bonds will continue to get reduced in one molecule one after another. This process will continue till all the hydrogens are exhausted.

Category III (Q76 to Q80)**(Carry 2 marks each. One or more options are correct. No negative marks)**

76. Which of the statements are incorrect ?

- (A) pH of a solution of salt of strong acid and weak base is less than 7.
 (B) pH of a solution of a weak acid and weak base is basic if $K_b < K_a$.
 (C) pH of an aqueous solution of 10^{-8} (M) HCl is 8.
 (D) Conjugate acid of NH_2^- is NH_3 .

Ans : (B, C)**Hint :**

- * pH of a solution of strong acid and weak base (say NH_4Cl) is less than 7.
- * For hydrolysis of salt of weak acid and weak base.
When $K_a > K_b$, $\text{pH} < 7$
- * pH of 10^{-8} M HCl (aq) will be less than 7.
- * Conjugate acid of NH_2^- is NH_3 . This is a true statement.

77. During the preparation of NH_3 in Haber's process, the promoter(s) used is / are –

- (A) PtO_2 (B) Mo (C) Mix of Al_2O_3 and K_2O (D) Fe and Mn

Ans : (B, C)**Hint :**Mo was used as promoter earlier. Now K_2O and Al_2O_3 are used as promoter.78. The correct statement(s) about B_2H_6 is / are :

- (A) All B atoms are sp^3 hybridised (B) It is paramagnetic
 (C) It contains 3C - 4e bonding (D) There are two types of H present

Ans : (A, D)**Hint :**In diborane, all boron atoms are sp^3 hybridised. It is diamagnetic and contains 3C – 2e bonds. There are two types of hydrogens – terminal and bridging.

79. Which of the following would produce enantiomeric products when reacted with methyl magnesium iodide ?

- (A) Benzaldehyde (B) Propiophenone (C) Acetone (D) Acetaldehyde

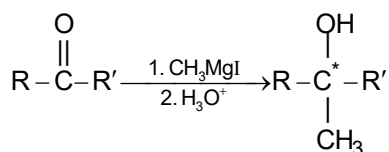
Ans : (A, B)**Hint :**

When R and R' are different and none of them is methyl, we will get enantiomeric product.

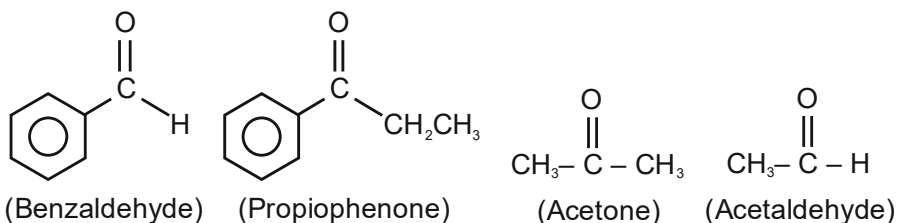

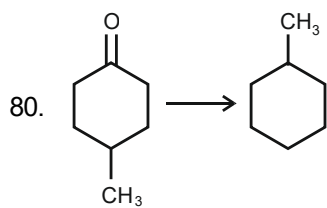

The above conversion can be carried out by,

- (A) Zn – Hg/Conc. HCl
(B) i. H_2NNH_2 ii. NaOH in ethylene glycol, Δ
(C) i. $\text{HSCH}_2\text{CH}_2\text{SH} / \text{H}^{\oplus}$ ii. H_2 / Ni
(D) Bromine water

Ans : (A, B, C)

Hint :

- (A) Zn - Hg / Conc. HCl – Clemmensen Reduction
(B) $\text{NH}_2 - \text{NH}_2$, NaOH in ethylene glycol, Δ – Wolf-Kishner reduction
(C) i. $\text{HSCH}_2\text{CH}_2\text{SH} / \text{H}^+$ ii. H_2 / Ni – Mozingo method.

These are known to reduce – CO – to – CH_2 –

