

Date: 17/05/2026



Aakash

Medical | IIT-JEE | Foundations

Corporate Office : AESL, 3rd Floor, Incuspaze Campus-2, Plot-13, Sector-18, Udyog Vihar,
Gurugram, Haryana-122015

Time : 3 hrs.

Questions & Answers

Max. Marks: 180

for

JEE (Advanced)-2026 (Paper-2)

PART-I : MATHEMATICS

SECTION 1 (Maximum Marks : 12)

- This section contains **FOUR (04)** questions.
- Each question has **FOUR** options (A), (B), (C) and (D). **ONLY ONE** of these four options is the correct answer.
- For each question, choose the option corresponding to the correct answer.
- Answer to each question will be evaluated **according to the following marking scheme:**

Full Marks : +3 If **ONLY** the correct option is chosen;

Zero Marks : 0 If none of the options is chosen (i.e. the question is unanswered);

Negative Marks : -1 In all other cases.

1. Let \vec{a} , \vec{b} be two vectors, and let P , Q and R be the points with position vectors \vec{a} , \vec{b} and $\vec{a} + \vec{b}$, respectively, with respect to the origin O . If $|\vec{a} + \vec{b}| = \sqrt{21}$, $|\vec{a} - \vec{b}| = 3$, and \vec{a} and $(\vec{a} - \vec{b})$ are perpendicular to each other, then the area of the triangle OPR is

1 out of 2

Aakashians*

Qualified for JEE (Adv.) 2026



37 YEARS OF CONTINUOUS SUCCESS

(A) $\sqrt{3}$

(B) $\frac{\sqrt{3}}{2}$

(C) $\frac{3\sqrt{3}}{2}$

(D) $\frac{3}{2}$

Answer (C)

2. Let T be the tangent to the parabola $y^2=16x$ at the point $(64, 32)$. Let L be the tangent to the same parabola at another point (x_1, y_1) on the parabola. If L and T are perpendicular to each other, then the distance between the point (x_1, y_1) and the focus of the parabola, is

(A) $\frac{15}{4}$

(B) 4

(C) $\frac{17}{4}$

(D) 5

Answer (C)

3. Let $y : (-\infty, \infty) \rightarrow (0, \infty)$, be the solution of the differential equation

$$\frac{dy}{dx} = \frac{e^{5x}y^3 + y^3}{e^x + e^xy^4},$$

satisfying $y(0) = \frac{1}{\sqrt{2}}$. Then the value of $y(\log_e 2)$ is

(A) $\sqrt{\frac{5 + \sqrt{35}}{2}}$

(B) $\sqrt{\frac{7 + \sqrt{53}}{2}}$

(C) $\frac{7 + \sqrt{53}}{2}$

(D) $\frac{5 + \sqrt{35}}{2}$

Answer (B)

4. The value of the definite integral $\int_0^2 \frac{1}{3^x + 3} dx$ is

(A) $\frac{1}{2}$

(B) $\frac{1}{3}$

(C) $\frac{\log_e 3}{3}$

(D) $\frac{\log_e 3}{2}$

Answer (B)

1

out of

2

Aakashians*

Qualified for JEE (Adv.) 2026

37 YEARS OF CONTINUOUS SUCCESS

AIR 93

© Piyush Shukla
1 Year Classroom

AIR 57

Sudhanshu K. Agarwal
1 Year Classroom

AIR 43

Adarsh Kumar Sharma
2 Year Classroom

AIR 27

Utkarsh Prakash
1 Year Classroom

AIR 11

Rajasthan
Topper

AIR 31

Ansh P
1 Year Classroom

AIR 55

Rishabh Choudhary
1 Year Classroom

AIR 68

Aman Gupta
1 Year Classroom

AIR 94

Sanku C Pradhan
1 Year Classroom

SECTION 2 (Maximum Marks : 20)

- This section contains **FIVE (05)** questions.
- Each question has **FOUR** options (A), (B), (C) and (D). **ONE OR MORE THAN ONE** of these four option(s) is(are) correct answer(s).
- For each question, choose the option(s) corresponding to (all) the correct answer(s).
- Answer to each question will be evaluated **according to the following marking scheme:**

Full Marks : +4 **ONLY** if (all) the correct option(s) is(are) chosen;
Partial Marks : +3 If all the four options are correct but **ONLY** three options are chosen;
Partial Marks : +2 If three or more options are correct but **ONLY** two options are chosen, both of which are correct;
Partial Marks : +1 If two or more options are correct but **ONLY** one option is chosen and it is a correct option;
Zero Marks : 0 If none of the options is chosen (i.e. the question is unanswered);
Negative Marks : -1 In all other cases.

5. Let \mathbb{R} denote the set of all real numbers. Consider the polynomial function $f: \mathbb{R} \rightarrow \mathbb{R}$ defined by

$$F(x) = \frac{d^{10}}{dx^{10}}((x^2 - 1)^{10}), \text{ for all } x \in \mathbb{R}.$$

Here $\frac{d^{10}}{dx^{10}}((x^2 - 1)^{10})$ is the 10th order derivative of the function $(x^2 - 1)^{10}$.

Then which of the following statements is (are) TRUE ?

- (A) The coefficient of x^8 in the polynomial $f(x)$ is $(-10) \left(\frac{18!}{8!} \right)$
- (B) The value of $f(1) + f(-1)$ is equal to $10!2^{11}$
- (C) The degree of the polynomial $f(x)$ is 10
- (D) The constant term of the polynomial $f(x)$ is $-\left(\frac{10!}{5!} \right)$

Answer (A, B, C)

6. Let a, b, c be positive integers in arithmetic progression such that the equation

$$ax^2 + bx + c = 0$$

has only integer solutions.

Then which of the following statements is (are) TRUE?

- (A) $c - b$ is an integer multiple of a
- (B) Both the roots of the equation $ax^2 + bx + c = 0$ are odd integers
- (C) If $c = 15$, then $ab = 8$
- (D) If $b = 8$, then $x = 3$ is a root of the equation $ax^2 + bx + c = 0$

Answer (A, B, C)

7. Let L be the straight line joining the points $P(1, 2, -1)$ and $Q(2, 3, 1)$. Let S be the foot of the perpendicular drawn from the point $R(4, -1, 5)$ to the line L . Another line passing through R intersects L at a point T such that the point S divides the line segment PT internally in the ratio $|PS| : |ST| = 1 : 2$, where $|PS|$ and $|ST|$ are the lengths of the line segments PS and ST , respectively.

Then which of the following statements is (are) TRUE?

- (A) The orthocentre of the triangle PRT is $\left(\frac{23}{5}, -4, \frac{31}{5}\right)$
- (B) The orthocentre of the triangle PRT is $(4, 3, 5)$
- (C) The area of the triangle PRT is $6\sqrt{5}$
- (D) The area of the triangle PRT is $18\sqrt{5}$

Answer (A, D)

8. Let $y = f(x)$ be the real valued function defined on the interval $(0, \infty)$, satisfying $y(1) = 0$ and the differential equation $x \frac{dy}{dx} = y - x^3$. Then which of the following statements is (are) TRUE?

- (A) The function f has a local minimum at $x = \frac{1}{\sqrt{3}}$
- (B) The function f has a local maximum at $x = \frac{1}{\sqrt{3}}$
- (C) The function f is increasing in the interval $(1, 2)$
- (D) If $g(x) = 4x^3 - 5x^2 + \frac{3}{2}x$ for $x > 0$, then the number of elements in the set $\{x \in (0, \infty) : f(x) = g(x)\}$ is 2

Answer (B, D)

9. Let \mathbb{R} denote the set of all real numbers and let $i = \sqrt{-1}$. Consider the matrices

$$S = \begin{bmatrix} 0 & -1 \\ 1 & 0 \end{bmatrix} \text{ and } T = \begin{bmatrix} 1 & 1 \\ 0 & 1 \end{bmatrix}.$$

Let a, b, c, d be real numbers such that

$$ST = \begin{bmatrix} a & b \\ c & d \end{bmatrix}.$$

Let

$$H = \{x + iy : x, y \in \mathbb{R} \text{ and } y > 0\}.$$

Then which of the following statements is (are) TRUE ?

- (A) $\frac{b + ia}{d + ic} = i$
- (B) If $\omega = \frac{-1 + i\sqrt{3}}{2}$, then $\frac{a\omega + b}{c\omega + d} = \omega$
- (C) If m is an integer greater than 2 such that $(ST)^2 = (ST)^m$, then m is an integer multiple of 8
- (D) If $z \in H$, then $\frac{az + b}{cz + d} \in H$

Answer (B, D)

1 out of 2

Aakashians*

Qualified for JEE (Adv.) 2026

AIR 93
Prayansh Chakrabarti
1 Year Classmate

AIR 57
Sudhant K Agarwal
1 Year Classmate

AIR 43
Adarsh Kumar Bhatnagar
2 Year Classmate

AIR 27
Utkarsh Prakash
Topper

AIR 11
Rajasthan Topper
Yash Wardhan
1 Year Classmate

AIR 31
Anshu P
1 Year Classmate

AIR 55
Rishabh Choudhary
1 Year Classmate

AIR 68
Aman Gupta
1 Year Classmate

AIR 94
Sanku C Pradhan
1 Year Classmate

37 YEARS OF CONTINUOUS SUCCESS

SECTION 3 (Maximum Marks : 20)

- This section contains **FIVE (05)** questions.
- The answer to each question is a **NUMERICAL VALUE**.
- For each question, enter the correct numerical value corresponding to the answer in the designated place using the mouse and the on-screen virtual numeric keypad.
- If the numerical value has more than two decimal places, **truncate/round-off** the value to **TWO** decimal places.
- Answer to each question will be evaluated **according to the following marking scheme**:

Full Marks : +4 If **ONLY** the correct numerical value is entered in the designated place;

Zero Marks : 0 In all other cases.

10. Let \mathbb{N} denote the set of all positive integers. Consider the sets

$$A = \{1, 2, 3, 4, 5\} \text{ and } B = \{1, 2, 3, 4, 5, 6, 7\}.$$

Let S be the set of all functions $f: A \rightarrow B$ such that $f(2) \neq 2$ and $f(4) \neq 4$. Consider the set

$$T = \{f \in S : \text{there exists a function } g: B \rightarrow \mathbb{N} \text{ such that } g(f(x)) = 2^x \text{ for all } x \in A\}.$$

Then the number of elements in the set T is _____.

Answer (1860.00)

11. A bookshelf contains 6 distinct books of Mathematics and 5 distinct books of Physics. From these 11 books, 6 books are chosen at random. Let X be the absolute value of the difference between the number of Mathematics books chosen and the number of Physics books chosen. If α is the mean of the random variable X then the value of 77α is _____.

Answer (100.00)

12. Consider a data consisting of 10 observations x_1, x_2, \dots, x_{10} , whose mean is 5 and variance is 7. If the mean and the variance of the first 8 observations x_1, x_2, \dots, x_8 are 4 and 3.5, respectively, and $x_9 < x_{10}$, then the value of $3x_9 + 2x_{10}$ is _____.

Answer (44.00)



1 out of 2 Aakashians*
Qualified for JEE (Adv.) 2026

AIR 93, AIR 57, AIR 43, AIR 27 (Uttar Pradesh Topper), AIR 11 (Rajasthan Topper), AIR 31, AIR 55, AIR 68, AIR 94

© Piyush Chandra, Subham K. Agarwal, Adarsh Kumar Bhatia, Vikram Khanna, Yash Wardhan, Ansh P, Karish Choudhary, Aman Gupta, Adil C. Pradhan

37 YEARS OF CONTINUOUS SUCCESS

13. Consider the ellipse E given by $\frac{x^2}{18} + \frac{y^2}{12} = 1$. Let H be the hyperbola whose eccentricity is the reciprocal of the eccentricity of E and whose foci are the same as that of E . Let P and Q be the points of intersection of H and the parabola $\sqrt{5}y = x^2$ in the first quadrant. Let d be the distance between P and Q .

If a and b are the integers such that $d^2 = a + b\sqrt{5}$, then the value of $a - b$ is _____.

Answer (18.00)

14. For a real number α , let $[\alpha]$ denote the greatest integer less than or equal to α . For a finite set S , let $|S|$ denote the number of elements in the set S .

Consider the functions $f: (-3, 3) \rightarrow (-\infty, \infty)$ and $g: (-3, 3) \rightarrow (-\infty, \infty)$ defined by

$$f(x) = [x^3] \log_e(1 + \sin^2(\pi(x - [x])))$$

and

$$g(x) = x^3 \sin^2(\pi \log_e(1 + x - [x])).$$

Let

$$A = \{x \in (-3, 3) : f \text{ is discontinuous at } x\}$$

And

$$B = \{x \in (-3, 3) : g \text{ is discontinuous at } x\}.$$

Then the value of $|A| + 2|B| - |A \cap B|$ is _____.

Answer (56.00)

SECTION 4 (Maximum Marks : 8)

- This section contains **TWO (02)** question stems.
- There are **TWO (02)** questions corresponding to each question stem.
- The answer to each question is a **NUMERICAL VALUE**.
- For each question, enter the correct numerical value corresponding to the answer in the designated place using the mouse and the on-screen virtual numeric keypad.
- If the numerical value has more than two decimal places, **truncate/round-off** the value to **TWO** decimal places.
- Answer to each question will be evaluated **according to the following marking scheme**:

Full Marks : +2 If **ONLY** the correct numerical value is entered in the designated place;

Zero Marks : 0 In all other cases.

1 out of 2
Aakashians*
Qualified for JEE (Adv.) 2026

AIR 93, AIR 57, AIR 43, AIR 27 (Uttar Pradesh Topper), AIR 11 (Rajasthan Topper), AIR 31, AIR 55, AIR 68, AIR 94

© Piyush Chakravarti, Sushant K Agarwal, Adarsh Kumar Sharma, Vikram Khanna, Yash Wardhan, Ansh P, Karish Choudhary, Arun Gupta, Anil C Prasad

37 YEARS OF CONTINUOUS SUCCESS

Question Stem for Question Nos. 15 and 16

Consider the curve C_1 given by $y = e^{-x}$ for $x \in [0, 10\pi]$, and the curve C_2 given by $y = e^{-x}(\sin x + \cos x)$ for $x \in [0, 10\pi]$. Let n be the total number of points of intersection of the curves C_1 and C_2 . Suppose that $\alpha_1, \alpha_2, \dots, \alpha_n \in [0, 10\pi]$ are the x -coordinates of the points of intersection of the curves C_1 and C_2 such that $\alpha_1 < \alpha_2 < \dots < \alpha_n$.

15. The value of n is _____.

Answer (11.00)

16. Let β be the area of the region enclosed between the curves C_1, C_2 , and the lines $x = \alpha_1$ and $x = \alpha_4$. Then the

value of $-\frac{1}{\pi} \log_e \left(\beta - 2e^{-\frac{\pi}{2}} \right)$ is _____.

Answer (02.50)

Question Stem for Question Nos. 17 and 18

Consider the ellipses given by

$$x^2 + 4y^2 = 1 \text{ and } 4x^2 + y^2 = 1.$$

17. Let P be the point in the first quadrant where the given ellipses intersect. If θ is the acute angle between the tangents to the given ellipses at the point P , then the value of $4 \tan \theta$ is _____.

Answer (07.50)

18. If α is the area of the common region that lies inside both the given ellipses, then the value of $\cot \alpha$ is _____.

Answer (00.75)



1 out of 2
Aakashians*
 Qualified for JEE (Adv.) 2026

AIR 93	AIR 57	AIR 43	AIR 27	AIR 11	AIR 31	AIR 55	AIR 68	AIR 94
Prayansh Shukla	Sudhant K. Agarwal	Adarsh Kumar Bhatia	Vishakh Khanna	Yash Wardhan	Ashik P	Kartik Choudhary	Aman Gupta	Sahil C. Pradhan
1 Year Olympiad	1 Year Olympiad	2 Year Olympiad	1 Year Olympiad	2 Year Olympiad	1 Year Olympiad	1 Year Olympiad	1 Year Olympiad	1 Year Olympiad

37 YEARS OF CONTINUOUS SUCCESS

PART-II : PHYSICS

SECTION 1 (Maximum Marks : 12)

- This section contains **FOUR (04)** questions.
- Each question has **FOUR** options (A), (B), (C) and (D). **ONLY ONE** of these four options is the correct answer.
- For each question, choose the option corresponding to the correct answer.
- Answer to each question will be evaluated **according to the following marking scheme:**

Full Marks : +3 If **ONLY** the correct option is chosen;

Zero Marks : 0 If none of the options is chosen (i.e. the question is unanswered);

Negative Marks : -1 In all other cases.

1. A metal wire of cross-sectional area 0.5 mm^2 and length 100 m is connected across a battery of e.m.f. 2 V and internal resistance 1Ω . The density, atomic mass and electrical conductivity of the metal are $6.35 \times 10^3 \text{ kg m}^{-3}$, 63.5 gm/mole and $2 \times 10^8 \text{ mho m}^{-1}$, respectively. Assuming one conduction electron per atom of the metal, the drift velocity (in mm s^{-1}) of the electrons in the wire is:

[Take Avogadro's number as 6×10^{23} and charge of the electron as $1.6 \times 10^{-19} \text{ C}$.]

- (A) 0.052 (B) 0.104
(C) 0.208 (D) 0.156

Answer (C)

2. A nuclear reactor starts producing a radioactive nuclide X from $t = 0$, at a constant rate of α per second. Each decay of X produces energy E_0 , which is utilized to heat a liquid of mass m and specific heat s . Assuming no heat loss from the liquid and taking λ as the decay constant of X , the rate of increase in the temperature of the liquid is:

- (A) $\frac{\alpha E_0}{ms} (1 - e^{-\lambda t})$ (B) $\frac{\alpha E_0}{ms} (e^{\lambda t} - 1)$
(C) $\frac{\lambda E_0}{ms} (1 - e^{-\lambda t})$ (D) $\frac{E_0}{ms} (\alpha - \lambda e^{-\lambda t})$

Answer (A)

1

out of

2

Aakashians*

Qualified for JEE (Adv.) 2026

AIR 93



Piyush Shukla
11th Classmate

AIR 57



Sahant K Agarwal
11th Classmate

AIR 43



Adarsh Kumar Sharma
11th Classmate

AIR 27



Vikram Khanna
11th Classmate

AIR 11



Yash Wardhan
11th Classmate

AIR 31



Ansh P
11th Classmate

AIR 55



Karthik Choudhary
11th Classmate

AIR 68



Ansh Gupta
11th Classmate

AIR 94



Adarsh C Pradhan
11th Classmate

37 YEARS OF CONTINUOUS SUCCESS

3. A beam of polychromatic light passes through a thin prism of prism angle 6° . The refractive index of the material of the prism varies with wavelength (λ) as $n(\lambda) = \alpha\lambda + \frac{\beta}{\lambda^2}$, where $\alpha = 3 \mu\text{m}^{-1}$ and $\beta = 0.096 \mu\text{m}^2$. If λ_{\min} is the wavelength at which the angle of minimum deviation D_m is smallest, then the correct value of D_m at λ_{\min} is
- (A) 6.4° (B) 4.8°
 (C) 3.2° (D) 2.4°

Answer (B)

4. A particle of mass m , and angular momentum ℓ is moving in a circular orbit of radius r_0 under the influence of an attractive force $\vec{F}(r) = -\frac{k}{r^2} \hat{r}$. Keeping its angular momentum unchanged, the particle is displaced radially by a small distance $\delta r \ll r_0$, due to which its radial distance varies periodically. The corresponding time period is:
- (A) $\frac{2\pi\ell^3}{mk^2}$
 (B) $2\pi\sqrt{\frac{m}{k}}$
 (C) $\frac{2\pi\ell^3}{3mk^2}$
 (D) $\frac{2\pi\ell^3}{5mk^2}$

Answer (A)

SECTION 2 (Maximum Marks : 20)

- This section contains **FIVE (05)** questions.
- Each question has **FOUR** options (A), (B), (C) and (D). **ONE OR MORE THAN ONE** of these four option(s) is(are) correct answer(s).
- For each question, choose the option(s) corresponding to (all) the correct answer(s).
- Answer to each question will be evaluated **according to the following marking scheme:**

Full Marks	:	+4	ONLY if (all) the correct option(s) is(are) chosen;
Partial Marks	:	+3	If all the four options are correct but ONLY three options are chosen;
Partial Marks	:	+2	If three or more options are correct but ONLY two options are chosen, both of which are correct;
Partial Marks	:	+1	If two or more options are correct but ONLY one option is chosen and it is a correct option;
Zero Marks	:	0	If none of the options is chosen (i.e. the question is unanswered);
Negative Marks	:	-1	In all other cases.

5. Consider two isosceles prisms 1 and 2 with prism angles A_1 and A_2 and refractive indices n_1 and n_2 , respectively, as shown in the figure. The faces a_1b_1 and a_2b_2 are parallel to each other and perpendicular to the mirror M . If a ray of light is incident on the face a_1c_1 and emerges from the face a_2c_2 , then the correct statement(s) is/are:

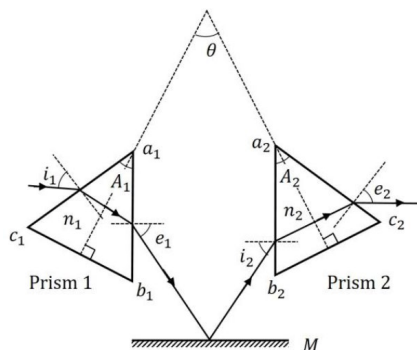

- (A) If both the prisms are at minimum deviation condition, then $\frac{n_2}{n_1} = \sin\left(\frac{A_1}{2}\right) / \sin\left(\frac{A_2}{2}\right)$
- (B) If prism 2 is at minimum deviation condition, then $\sin i_1 = n_2 \sin\left(\frac{A_2}{2}\right)$ is always true.
- (C) If both the prisms 1 and 2 are thin and are at minimum deviation condition with angles of deviation δ_{m1} and δ_{m2} , respectively, then $\theta = \frac{\delta_{m1}}{2(n_1 - 1)} + \frac{\delta_{m2}}{2(n_2 - 1)}$.
- (D) If prism 1 is at minimum deviation condition, then $\sin i_2 = n_1 \sin\left(\frac{A_1}{2}\right)$ is always true.

Answer (A, C, D)

6. In a vacuum chamber, a particle of charge $1 \mu\text{C}$ and mass 1 mg is projected with a velocity $(\hat{i} + 2\hat{j}) \text{ ms}^{-1}$ from the XZ plane at time $t = 0$ in an electric field of $1\hat{j} \text{ Vm}^{-1}$. At $t = 0.2 \text{ s}$, the electric field is switched off and a magnetic field of $6\hat{j} \text{ T}$ is switched on. The acceleration due to gravity is $-10\hat{j} \text{ ms}^{-2}$. Correct option(s) is/are:
- (A) The vertical distance of the particle from the XZ plane at $t = 0.3 \text{ s}$ is 15 cm .
- (B) The vertical distance of the particle from the XZ plane at $t = 0.4 \text{ s}$ is 10 cm .
- (C) The radius of the trajectory of the particle for $t > 0.2 \text{ s}$ is 20 cm .
- (D) The particle will be in the XZ plane at $t = 0.35 \text{ s}$.

Answer (A, C)

1 out of 2

Aakashians*

Qualified for JEE (Adv.) 2026

AIR 93

Prayansh Shukla
1 Year Old

AIR 57

Sudhanshu K. Agarwal
1 Year Old

AIR 43

Adarsh Kumar Sharma
2 Year Old

AIR 27

Utkarsh Pradish
Topper

AIR 11

Rajasthan Topper

AIR 31

Yash Wardhan
1 Year Old

AIR 55

Rishabh Choudhary
1 Year Old

AIR 68

Amit Gupta
1 Year Old

AIR 94

Sahil C. Pradhan
1 Year Old

37 YEARS OF CONTINUOUS SUCCESS

7. Two charges $Q_1 = q$ and $Q_2 = mq$ are placed at the points $P_1(a, b)$ and $P_2(ma, mb)$, respectively, in the XY plane, where $a, b \neq 0$ and $m \neq 0, 1$. If V_1 is the potential at a point in the XY plane due to charge Q_1 and V_2 is the potential at that point due to charge Q_2 . Correct statement(s) for the points at which $|V_1| = |V_2|$ is/are:
- (A) For $m = -1$, locus of these points is $ax + by = 0$
- (B) For $m = 2$, the locus of these points is a circle of radius $\frac{2}{3}\sqrt{a^2 + b^2}$ centered at $(\frac{2}{3}a, \frac{2}{3}b)$
- (C) For $m = -2$, the locus of these points is a circle of radius $2\sqrt{a^2 + b^2}$ centered at $(2a, 2b)$
- (D) For $m = -3$, locus of these points is $3bx + 3ay = 0$

Answer (A, B, C)

8. Consider an electric dipole comprising two charges $+q$ and $-q$ each with mass m , separated by a fixed distance d and initially at rest with its dipole moment pointing along \hat{i} . A uniform electric field $E\hat{j}$ is turned on at time $t = 0$ and it is turned off at $t = t_f$, when the dipole moment makes an angle θ_f with \hat{i} . Neglecting any sources of energy loss, correct option(s) is/are:
- (A) The centre of mass of the dipole is deflected towards \hat{j} in the presence of the field.
- (B) If the magnitude of the final angular velocity $\omega_f = \sqrt{\frac{2qE}{md}}$, then $\theta_f = \frac{\pi}{6}$
- (C) If $\theta_f = \pi/3$, then the change in kinetic energy of the dipole is given by $2\sqrt{3} qEd$
- (D) For $\theta_f = \pi/4$, the dipole rotates around its center of mass with a constant angular velocity after $t > t_f$

Answer (B, D)

9. Ten moles of an ideal monoatomic gas, initially in state a at atmospheric pressure and temperature $T_a = 27^\circ\text{C}$, is enclosed in a metal cylinder of volume V_0 fitted with a frictionless piston. The gas is suddenly compressed to state b with volume $V_0/3$. Now, keeping the piston stationary, the cylinder is submerged in a water bath of temperature 11°C until the gas reaches the temperature of the water bath, which is denoted as state c . Finally, while still in the water bath, the piston is brought slowly to its initial position, which is denoted as state f . If R is universal gas constant, then the correct option(s) is/are:

[Given: $9^{1/3} = 2.08$]

1 out of 2
Aakashians*
Qualified for JEE (Adv.) 2026

AIR 93	AIR 57	AIR 43	AIR 27 Uttar Pradesh Topper	AIR 11 Rajasthan Topper	AIR 31	AIR 55	AIR 68	AIR 94
Chayansh Shukla 1 Year Old	Sudhant K Agarwal 1 Year Old	Adarsh Kumar Sharma 2 Year Old	Vikram Khanna 1 Year Old	Yash Wardhan 2 Year Old	Ashy P 1 Year Old	Kartik Choudhary 1 Year Old	Aman Gupta 1 Year Old	Sahil C Pradhan 2 Year Old

37 YEARS OF CONTINUOUS SUCCESS

(A) The schematic P-V diagram of the processes described above is:

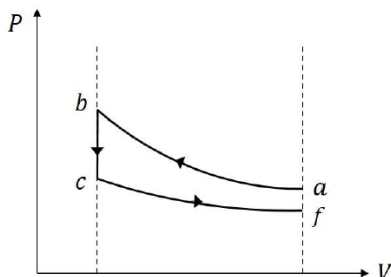

(B) The change in internal energy in going from state a to b is $4860R$.

(C) The net change in the internal energy in the whole process is $-240R$.

(D) The pressure and temperature of the state b are 2.08 times the atmospheric pressure and 624 K, respectively.

Answer (A, B, C)

SECTION 3 (Maximum Marks : 20)

- This section contains **FIVE (05)** questions.
- The answer to each question is a **NUMERICAL VALUE**.
- For each question, enter the correct numerical value corresponding to the answer in the designated place using the mouse and the on-screen virtual numeric keypad.
- If the numerical value has more than two decimal places, **truncate/round-off** the value to **TWO** decimal places.
- Answer to each question will be evaluated **according to the following marking scheme:**

Full Marks : +4 If **ONLY** the correct numerical value is entered in the designated place;

Zero Marks : 0 In all other cases.

10. Two thin wires, Wire-1 of diameter 0.650 mm and Wire-2 of unknown diameter d are given. To obtain the value of d , the diameter of the two wires are measured with a screw gauge. The screw gauge has a pitch of 0.5 mm and there are 100 divisions on the circular scale (CS). The smallest division on the linear scale (LS) is 0.5 mm. The table shows the readings of LS and CS for the measurements. The value of d (in μm) is :

	Readings	
	LS (mm)	CS
Wire-1	0.5	42
Wire-2	1.5	95

Answer (1915.00)

1 out of 2

Aakashians*

Qualified for JEE (Adv.) 2026

AIR 93

Prayansh Shukla

AIR 57

Sudhant K Agarwal

AIR 43

Adarsh Kumar Sharma

AIR 27

Utkarsh Pradish Topper

AIR 11

Rajasthan Topper

AIR 31

Aditya P

AIR 55

Ranil Choudhary

AIR 68

Aman Gupta

AIR 94

Sahil C Pradhan

37 YEARS OF CONTINUOUS SUCCESS

11. In a single slit diffraction experiment, a slit of width (0.016 ± 0.002) mm is used to measure the wavelength of a monochromatic light source. In the diffraction pattern, the angular distance between the central maximum and first minimum is measured to be $(2^\circ \pm 40')$. The value of the fractional error in the measurement of wavelength is: [Given: $\sin(2^\circ) = 0.035$]

Answer (0.46)

12. As shown in the figure, a ray AB of unpolarized light enters from water of refractive index $n_w = 4/3$ into a medium of refractive index $n_p = 4/\sqrt{3}$ after passing through a glass plate of refractive index $n_g = 1.5$ and a layer of water. At a particular incident angle i the reflected ray CD is polarized in the direction as shown in the figure. The value of i (in degrees) is:

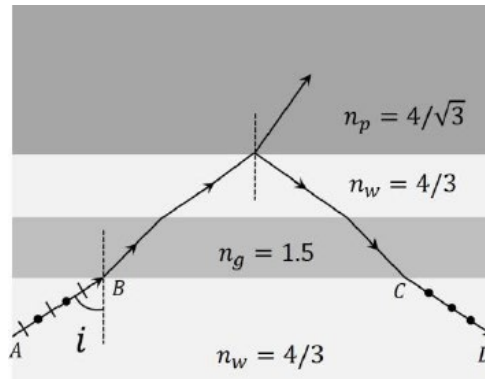

Answer (60.00)

13. As shown in the figure, the resistance of a galvanometer G can be found by the half-deflection method. Here the resistance R_2 is adjusted such that when the key K is closed the deflection in the galvanometer becomes half of the value as compared to when K is open. Half-deflection is obtained at $R_2 = 4 \Omega$ and thus the galvanometer resistance is found to be 6Ω . In this half-deflection condition the current (in mA) through the resistor R_1 is:

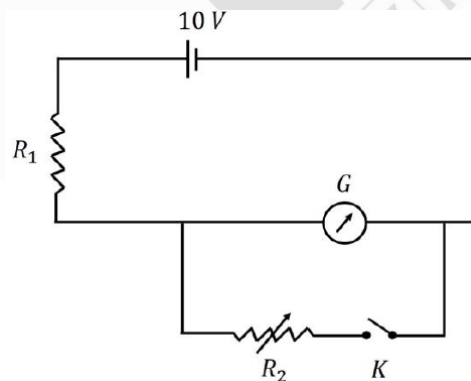

Answer (694.44)

1

out of

2

Aakashians*

Qualified for JEE (Adv.) 2026

AIR 93	AIR 57	AIR 43	AIR 27 Uttar Pradesh Topper	AIR 11 Rajasthan Topper	AIR 31	AIR 55	AIR 68	AIR 94
Chayush Shukla 1 Year Old	Sudhant K Agarwal 1 Year Old	Adarsh Kumar Sharma 2 Year Old	Vishakh Khanna 1 Year Old	Yash Wardhan 1 Year Old	Ashy P 1 Year Old	Kartik Choudhary 1 Year Old	Aman Gupta 1 Year Old	Sahil C Pradhan 1 Year Old

For more information visit www.aakashians.com

37 YEARS OF CONTINUOUS SUCCESS

14. In a new system of units, the units of mass, length, time and current are 5 kg, 5 m, 5 s and 5 A, respectively. If μ_0 and ϵ_0 are the permeability and permittivity of free space, respectively, then in this new system of units, the magnitude of one SI unit of $\sqrt{\mu_0/\epsilon_0}$, is:

Answer (25.00)

SECTION 4 (Maximum Marks : 8)

- This section contains **TWO (02)** question stems.
- There are **TWO (02)** questions corresponding to each question stem.
- The answer to each question is a **NUMERICAL VALUE**.
- For each question, enter the correct numerical value corresponding to the answer in the designated place using the mouse and the on-screen virtual numeric keypad.
- If the numerical value has more than two decimal places, **truncate/round-off** the value to **TWO** decimal places.
- Answer to each question will be evaluated **according to the following marking scheme**:

Full Marks : +2 If **ONLY** the correct numerical value is entered in the designated place;

Zero Marks : 0 In all other cases.

Question stem for Question Nos. 15 and 16

A container of height 2 m, length 2 m and breadth 1 m is made of insulating vertical walls and two large area horizontal metal plates (M_1 and M_2) which extend far beyond the vertical walls in all directions. The container is partitioned into two equal chambers with a thin insulating vertical wall. The partition wall contains a small hole of cross-sectional area $\sqrt{10}$ cm² near its bottom edge. Initially the hole is closed and the left chamber of the container is completely filled with a liquid of dielectric constant $\epsilon_r = 15$ and the right chamber is empty ($\epsilon_r = 1$). At time $t = 0$, the hole is opened and the liquid flows from the left chamber to the right chamber. In both the chambers, the space above the liquid has $\epsilon_r = 1$ and is maintained at atmospheric pressure. The schematic of the container at a time $t > 0$ is shown in the figure.

[Given: acceleration due to gravity is 10 ms⁻².]

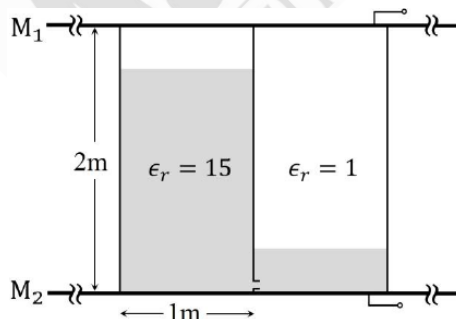

1 out of 2

Aakashians*

Qualified for JEE (Adv.) 2026

AIR 93	AIR 57	AIR 43	AIR 27 Uttar Pradesh Topper	AIR 11 Bajasthan Topper	AIR 31	AIR 55	AIR 68	AIR 94
<small>Prayansh Shukla</small>	<small>Sudhant K Agarwal</small>	<small>Adarsh Kumar Sharma</small>	<small>Vikram Khanna</small>	<small>Yash Wardhan</small>	<small>Ashu P</small>	<small>Ranil Choudhary</small>	<small>Aman Gupta</small>	<small>Sahil C Pradhan</small>
<small>1 Year Candidate</small>	<small>1 Year Candidate</small>	<small>2 Year Candidate</small>	<small>1 Year Candidate</small>	<small>1 Year Candidate</small>	<small>1 Year Candidate</small>	<small>1 Year Candidate</small>	<small>1 Year Candidate</small>	<small>1 Year Candidate</small>

37 YEARS OF CONTINUOUS SUCCESS

15. The height (in m) of the liquid in left chamber at $t = 500$ s is:

Answer (01.25)

16. The difference in the capacitance (in F) between the metal plates at $t = 0$ and that at $t = 500$ s is $(8 - n) \epsilon_0$, where ϵ_0 is the permittivity of free space. The value of n is:

Answer (01.97)

Question Stem for Question Nos. 17 and 18

A uniform circular disk of radius 0.2 m and mass 1 kg is pivoted at its top point C such that it can rotate freely around C in the XY plane, as shown in the figure. Initially, when the disk is at rest, a particle of mass 20 g, travelling along negative x direction in the XY plane with speed 100 ms^{-1} , hits the circumference of the disk at a point P. After collision the particle moves along negative y direction at a speed of 90 ms^{-1} .

[Given: the acceleration due to gravity (g) = $-10 \hat{j} \text{ ms}^{-2}$]

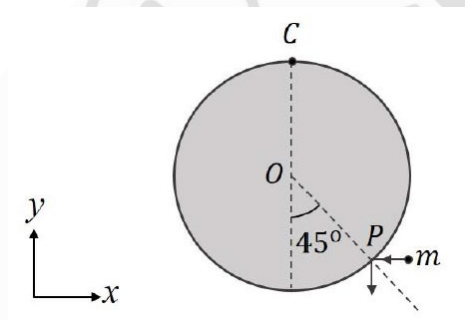

17. After the collision the disk starts to rotate around point C in the XY plane. The maximum change in the height (in m) of its centre O is:

Answer (00.15)

18. Amount of energy loss (in J) in the collision is:

Answer (17.47)

1

out of

2

Aakashians*

Qualified for JEE (Adv.) 2026

AIR 93	AIR 57	AIR 43	AIR 27 Uttar Pradesh Topper	AIR 11 Rajasthan Topper	AIR 31	AIR 55	AIR 68	AIR 94
Chayush Shukla 1 Year Old	Sudhant K Agarwal 1 Year Old	Adarsh Kumar Sharma 2 Year Old	Vikram Khanna 1 Year Old	Yash Wardhan 2 Year Old	Ashy P 1 Year Old	Rishabh Choudhary 1 Year Old	Aman Gupta 1 Year Old	Sahil C Pradhan 2 Year Old

*As per the website: JEE (Adv.) 2026, ranked 16, 20, 21, 22, 23, 24, 25, 26, 27, 28, 29, 30, 31, 32, 33, 34, 35, 36, 37, 38, 39, 40, 41, 42, 43, 44, 45, 46, 47, 48, 49, 50, 51, 52, 53, 54, 55, 56, 57, 58, 59, 60, 61, 62, 63, 64, 65, 66, 67, 68, 69, 70, 71, 72, 73, 74, 75, 76, 77, 78, 79, 80, 81, 82, 83, 84, 85, 86, 87, 88, 89, 90, 91, 92, 93, 94, 95, 96, 97, 98, 99, 100.

37 YEARS OF CONTINUOUS SUCCESS

PART-III : CHEMISTRY

SECTION 1 (Maximum Marks : 12)

- This section contains **FOUR (04)** questions.
- Each question has **FOUR** options (A), (B), (C) and (D). **ONLY ONE** of these four options is the correct answer.
- For each question, choose the option corresponding to the correct answer.
- Answer to each question will be evaluated **according to the following marking scheme:**

Full Marks : +3 If **ONLY** the correct option is chosen;

Zero Marks : 0 If none of the options is chosen (i.e. the question is unanswered);

Negative Marks : -1 In all other cases.

1. At 300 K, the molar conductivities of the aqueous solutions of three salts at two different concentrations are given below :

Salt	Concentration (M)	Molar Conductivity (S cm ² mol ⁻¹)
NaNO ₃	0.01	111
	0.04	101
NaCl	0.01	117
	0.04	107
AgNO ₃	0.01	125
	0.04	116

The conductivity of a saturated aqueous solution of AgCl is 1.40×10^{-6} S cm⁻¹ at 300 K. If the solubility of AgCl in water at 300 K is X mol L⁻¹, then log₁₀(X⁻¹) is

(Assume that AgCl dissolved in water ionizes completely and that the molar conductivity of saturated AgCl solution is equal to its limiting molar conductivity.)

- (A) 3 (B) 4
(C) 5 (D) 6

Answer (C)

2. The correct order of ONO bond angle in the given species is

- (A) NO₂⁺ < NO₂ < NO₃⁻ < NO₂⁻ (B) NO₂⁻ < NO₃⁻ < NO₂ < NO₂⁺
(C) NO₃⁻ < NO₂⁻ < NO₂ < NO₂⁺ (D) NO₂⁻ < NO₃⁻ < NO₂⁺ < NO₂

Answer (B)

1

out of

2

Aakashians*

Qualified for JEE (Adv.) 2026

37 YEARS OF CONTINUOUS SUCCESS

3. Natural rubber on complete ozonolysis ($O_3/Zn-H_2O$) gives compound **X** as the major product. **X** gives positive iodoform and Tollen's tests. **X** on heating with aqueous NaOH gives **Y** as the major product. **Y** is

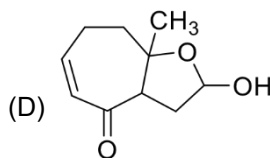
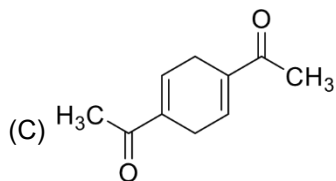
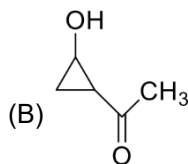
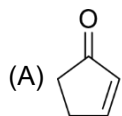

Answer (A)

4. A known artificial sweetener **X** is composed of 4-chloro-4-deoxy- α -D-galactose and 1,6-dichloro-1,6-dideoxy- β -D-fructose joined by a glycosidic linkage. Structure of D-galactose is given below:

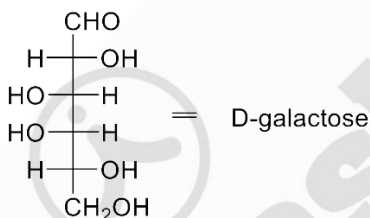

The correct structure of **X** is

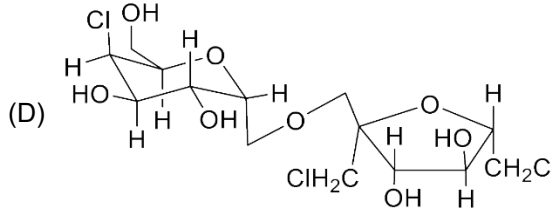
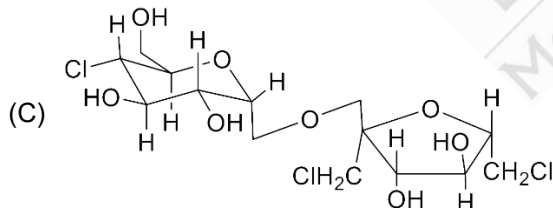
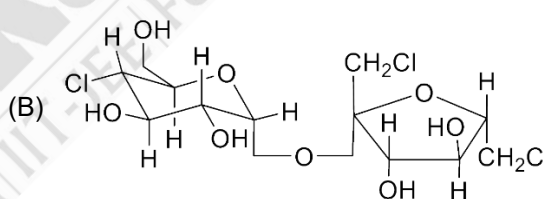
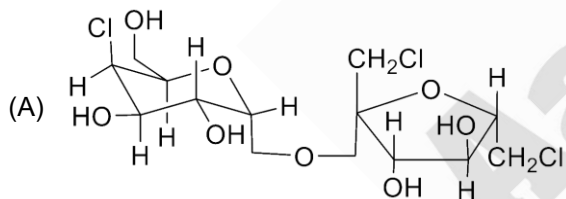

Answer (A)

1

out of 2

Aakashians*

Qualified for JEE (Adv.) 2026

37 YEARS OF CONTINUOUS SUCCESS

SECTION 2 (Maximum Marks : 20)

- This section contains **FIVE (05)** questions.
- Each question has **FOUR** options (A), (B), (C) and (D). **ONE OR MORE THAN ONE** of these four option(s) is(are) correct answer(s).
- For each question, choose the option(s) corresponding to (all) the correct answer(s).
- Answer to each question will be evaluated **according to the following marking scheme:**

Full Marks : +4 **ONLY** if (all) the correct option(s) is(are) chosen;

Partial Marks : +3 If all the four options are correct but **ONLY** three options are chosen;

Partial Marks : +2 If three or more options are correct but **ONLY** two options are chosen, both of which are correct;

Partial Marks : +1 If two or more options are correct but **ONLY** one option is chosen and it is a correct option;

Zero Marks : 0 If none of the options is chosen (i.e. the question is unanswered);

Negative Marks : -1 In all other cases.

5. For a first-order reaction $R \rightarrow P$ at a given temperature, k is the rate constant. For this reaction, at the given temperature, the concentrations of R and P at a time t are $[R]$ and $[P]$, respectively. The correct graphical representation(s) for this reaction is(are)

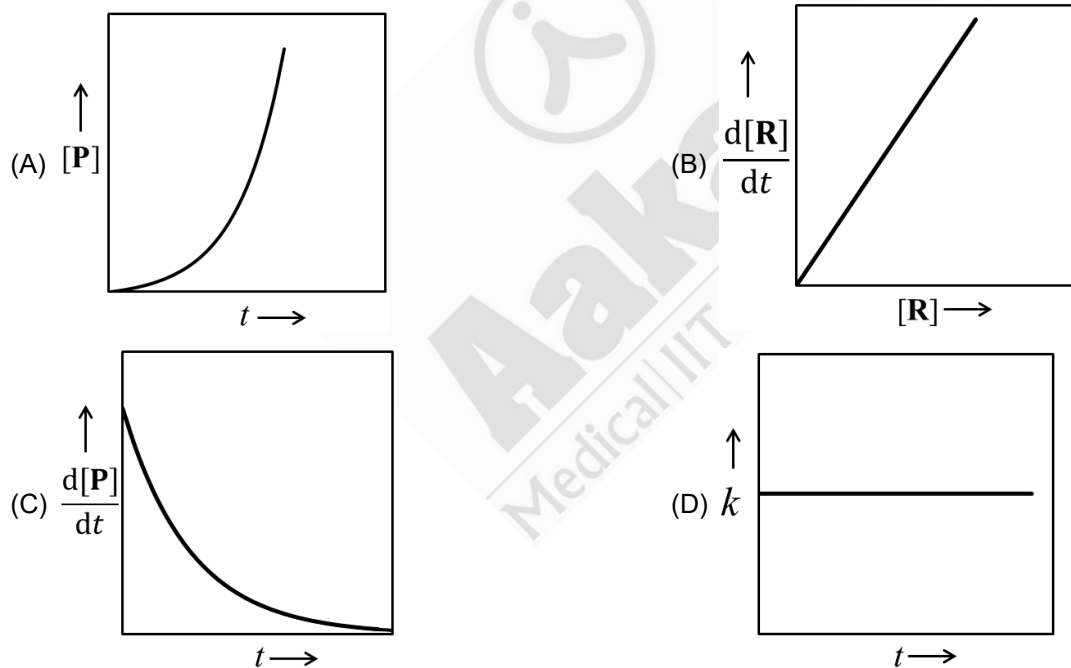

Answer (B, C, D)

1 out of 2

Aakashians*

Qualified for JEE (Adv.) 2026

AIR 93, AIR 57, AIR 43, AIR 27 (Uttar Pradesh Topper), AIR 11 (Rajasthan Topper), AIR 31, AIR 55, AIR 68, AIR 94

© Piyush Chakravarti, Subham K. Agarwal, Adarsh Kumar Sharma, Vikram Khanna, Yash Wardhan, Ansh P, Karish Choudhary, Arun Gupta, Anil C. Prasad

For more information visit www.aakash.ac.in

37 YEARS OF CONTINUOUS SUCCESS

6. Correct statement(s) about the compounds **P**, **Q** and **R** is(are)

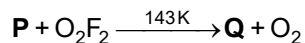
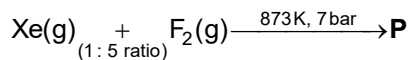

- (A) **P** has two lone pairs of electrons on the central atom.
- (B) **Q** has a perfect octahedral geometry.
- (C) **Q** can act as a fluorinating agent.
- (D) The molecular structure of **R** is trigonal pyramidal.

Answer (A, C, D)

7. The correct statement(s) regarding the periodic properties of elements is(are)

- (A) Second ionization enthalpy of carbon atom is less than that of boron atom.
- (B) Increasing order of ionic radii: $\text{Al}^{3+} < \text{Mg}^{2+} < \text{Na}^+$
- (C) Under identical conditions, in solid state, the density of potassium metal is more than density of sodium metal.
- (D) The H–H bond is weaker than F–F bond.

Answer (A, B)

8. In the following reaction sequence, **P**, **Q**, **S** and **T** are the major products.

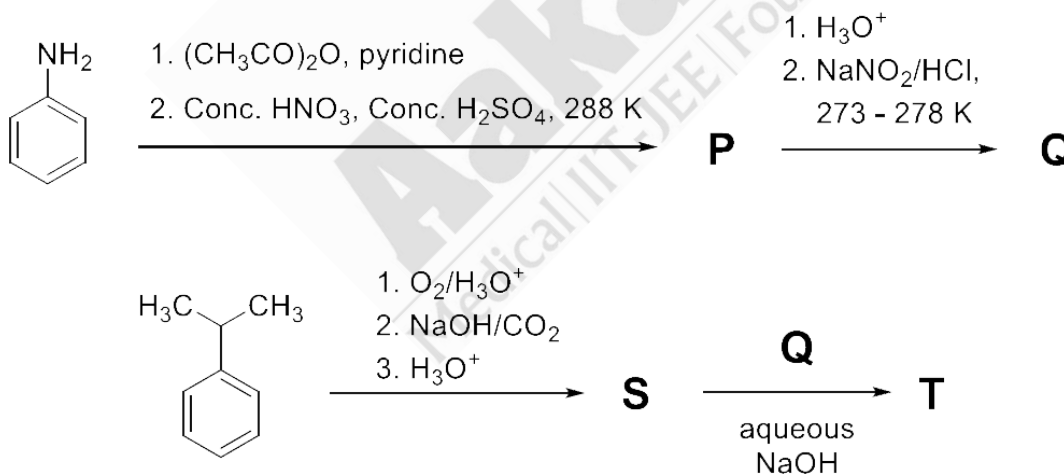

The correct statement(s) about **P**, **Q**, **S** and **T** is(are)

1

out of

2

Aakashians*

Qualified for JEE (Adv.) 2026

AIR 93	AIR 57	AIR 43	AIR 27	AIR 11	AIR 31	AIR 55	AIR 68	AIR 94
Piyush Shukla	Sudhant K Agarwal	Adarsh Kumar Bhatia	Vishakh Khambh	Yash Wardhan	Ashy P	Rishabh Choudhary	Aman Gupta	Sahil C Pradhan
1 Year Olympiad	1 Year Olympiad	2 Year Olympiad	1 Year Olympiad	1 Year Olympiad	1 Year Olympiad	1 Year Olympiad	1 Year Olympiad	1 Year Olympiad

37 YEARS OF CONTINUOUS SUCCESS

- (A) **Q** on treatment with ethanol generates an aromatic aldehyde.
- (B) **S** gives positive phthalein dye test.
- (C) **P** is a dinitro compound.
- (D) **T** is a coloured compound.

Answer (B, D)

9. The correct statement(s) regarding sugars is(are)

Given : Specific rotations of L-(–)-glucose and L-(+)-fructose are -52.5° and $+92.5^\circ$, respectively.

- (A) On treatment with HNO_3 , gluconic acid is oxidized to saccharic acid, whereas glucose is not oxidized to saccharic acid.
- (B) Fructose gives a positive Fehling's test because it isomerises to glucose and another aldohexose in the presence of Fehling's reagent.
- (C) Invert sugar is an equimolar mixture of D-glucose and D-fructose formed after hydrolysis of the corresponding disaccharide.
- (D) Specific rotation of invert sugar is -40° .

Answer (B, C)

SECTION 3 (Maximum Marks : 20)

- This section contains **FIVE (05)** questions.
- The answer to each question is a **NUMERICAL VALUE**.
- For each question, enter the correct numerical value corresponding to the answer in the designated place using the mouse and the on-screen virtual numeric keypad.
- If the numerical value has more than two decimal places, **truncate/round-off** the value to **TWO** decimal places.
- Answer to each question will be evaluated **according to the following marking scheme:**

Full Marks : +4 If **ONLY** the correct numerical value is entered in the designated place;
Zero Marks : 0 In all other cases.

10. X^{a+} and Y^{b+} are hydrogen-like species. The wavelength of light absorbed during the transition between the states with principal quantum numbers $n = 1$ and $n = 2$ of X^{a+} is λ . The wavelength of light absorbed during the transition between the states with principal quantum numbers $n = 2$ and $n = 4$ of Y^{b+} is 9λ . The lowest possible value of $(a + b)$ is _____.

Answer (03.00)

1 out of 2 Aakashians* Qualified for JEE (Adv.) 2026

37 YEARS OF CONTINUOUS SUCCESS

11. At a given temperature, 0.45 g of acetic acid in 50 mL of water is shaken with 1.0 g of charcoal and the pH of the resulting solution is 3.0. Assume, the adsorption of acetic acid from the aqueous solution by charcoal follows Freundlich isotherm,

$$\frac{x}{m} = kC^{1/n}$$

If the plot of $\log_{10}(x/m)$ against $\log_{10}C$ gives a straight line with slope 1, the value of k in $L \text{ mol}^{-1}$ is ____.

Given: The molar mass of acetic acid is 60 g mol^{-1} .

The acid dissociation constant of acetic acid is 1.0×10^{-5} at the given temperature.

x is the mass (in grams) of acetic acid adsorbed.

m is the mass (in grams) of charcoal.

C is the equilibrium concentration of acetic acid in the solution after the adsorption is complete.

k and n are constants for acetic acid–charcoal system at the given temperature.

Answer (01.50)

12. In a solvent **S**, a compound **B** is partially dissociated into **C** and **D** as given below:



B, **C** and **D** are non-volatile in nature. The molar mass of **B** is 10 times the molar mass of **S**. The standard boiling point and the standard enthalpy of vaporization of **S** are 400 K and $10R \text{ J mol}^{-1}$, respectively (R is the gas constant in $\text{J K}^{-1} \text{ mol}^{-1}$). A solution of **B** in **S** with an initial concentration of **B** as 0.25% (mass/mass) has a boiling point of 408 K at 1 bar pressure. In this solution, the mole percent of **B** that has been dissociated is ____.

Answer (33.16)

13. Consider that the coordinating atoms of the ligands in *cis*- $[\text{Co}(\text{NH}_3)_4\text{Cl}_2]\text{Cl}$ and *mer*- $[\text{Co}(\text{NH}_3)_3\text{Cl}_3]$ octahedral complexes are at the vertices of an octahedron. The sum of total number of the triangular faces in both the complexes having one N atom and two Cl atoms as their corners is ____.

Answer (06.00)

14. In the following reaction sequence, major products **X** and **Y** are acyclic monomers.

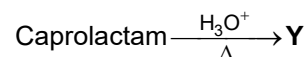
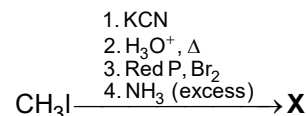

1

out of

2



Aakashians*

Qualified for JEE (Adv.) 2026



37 YEARS OF CONTINUOUS SUCCESS

AIR 93



Rishabh Shukla
1 Year Old Student

AIR 57



Sudhanshu K. Agarwal
1 Year Old Student

AIR 43



Adarsh Kumar Sharma
2 Year Old Student

AIR 27



Vishakh Khambh
1 Year Old Student

AIR 11



Yash Wardhan
1 Year Old Student

AIR 31



Ansh P
1 Year Old Student

AIR 55



Rishabh Choudhary
1 Year Old Student

AIR 68



Aman Gupta
1 Year Old Student

AIR 94



Sahil C. Pradhan
1 Year Old Student

*As per the website of JEE (Adv.) 2026 results of 2025 Aakash students only.

500 mol of **X** completely reacts with 500 mol of **Y** to give 1 mol of a single biodegradable acyclic copolymer **Z** as the only product. The amount of **Z** formed in grams is _____.

Given:

Atomic mass (in amu): H : 1, C : 12, N : 14, O : 16, Br : 80

Answer (85018.00)

SECTION 4 (Maximum Marks : 8)

- This section contains **TWO (02)** question stems.
- There are **TWO (02)** questions corresponding to each question stem.
- The answer to each question is a **NUMERICAL VALUE**.
- For each question, enter the correct numerical value corresponding to the answer in the designated place using the mouse and the on-screen virtual numeric keypad.
- If the numerical value has more than two decimal places, **truncate/round-off** the value to **TWO** decimal places.
- Answer to each question will be evaluated **according to the following marking scheme:**

Full Marks : +2 If **ONLY** the correct numerical value is entered in the designated place;

Zero Marks : 0 In all other cases.

Question Stem for Question Nos. 15 and 16

Two volatile liquids **A** and **B** form an ideal solution. Consider a 5 molal solution of **B** in **A** inside a closed container having a total vapour pressure of 100 mm Hg at 300 K. The vapour pressure of pure **A** at 300K is 105 mm Hg. Assume that **A** and **B** behave as ideal gases in the vapour phase.

Given:

The gas constant $R = 0.08 \text{ L atm K}^{-1} \text{ mol}^{-1}$

Molar mass of **A** is 50 g mol^{-1}

Molar mass of **B** is 57 g mol^{-1}

Density of liquid **B** at 300 K is 0.5 g/mL

$1 \text{ atm} = 760 \text{ mm Hg}$

15. At 300 K, the ratio of the molar volume of pure **B** in vapour phase to its molar volume in liquid phase is _____.

Answer (2000.00)

16. The mole fraction of **B** in vapour phase which is in equilibrium with this solution is _____.

Answer (00.16)

1 out of 2 Aakashians*
Qualified for JEE (Adv.) 2026

37 YEARS OF CONTINUOUS SUCCESS

AIR 93, AIR 57, AIR 43, AIR 27 (Uttar Pradesh Topper), AIR 11 (Bajasthan Topper), AIR 31, AIR 55, AIR 68, AIR 94

Question Stem for Question Nos. 17 and 18

Consider the following reaction sequence in which **J**, **K**, **L** and **M** are the major products.

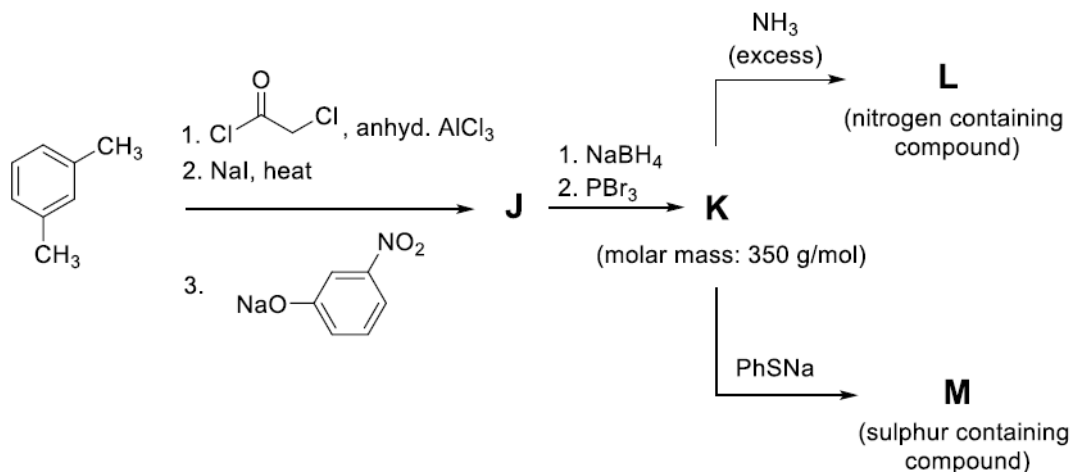

Given : Atomic mass (in amu) : H : 1, C : 12, N : 14, O : 16, S : 32, Br : 80, Ba : 137

17. The volume of 1 M aqueous H2SO4 required to completely neutralize the ammonia evolved from 5.72 g of **L** in Kjeldahl's method of nitrogen estimation is _____ mL.

Answer (10.00)

18. In sulphur estimation by Carius method, the amount of BaSO4 formed from 3.79 g of **M** is _____ g.

Answer (02.33)



1 out of 2

Aakashians*

Qualified for JEE (Adv.) 2026

AIR 93	AIR 57	AIR 43	AIR 27 Uttar Pradesh Topper	AIR 11 Rajasthan Topper	AIR 31	AIR 55	AIR 68	AIR 94
Prayansh Shukla	Sudhant K. Agarwal	Adarsh Kumar Sharma	Vishakh Khanna	Yash Wardhan	Ashu P.	Rishabh Choudhary	Aman Gupta	Sanku C. Pradhan
1 Year Classroom	1 Year Classroom	2 Year Classroom	1 Year Classroom	1 Year Classroom	1 Year Classroom	1 Year Distance (English)	1 Year Classroom	1 Year Classroom

37 YEARS OF CONTINUOUS SUCCESS

- 23 -