

04/04/2026

Morning



Aakash

Medical | IIT-JEE | Foundations

Corporate Office : AESL, 3rd Floor, Incuspaze Campus-2, Plot-13, Sector-18, Udyog Vihar,
Gurugram, Haryana-122015

Memory Based Answers & Solutions

Time : 3 hrs.

for

M.M. : 300

JEE (Main)-2026 (Online) Phase-2

(Physics, Chemistry and Mathematics)

Don't guess your JEE Main score.

Calculate it Instantly

with our

JEE Main Score Calculator.

HOW TO GET YOUR SCORES

- Open your response sheet on the JEE Main Site
- Copy the link from the browser's Address bar
- Paste it into the required field in the Calculator



jee-marks-calculator.aakash.ac.in/



Scan the QR code
to know more.

Our Problem *Solvers* shine bright in **JEE 2025**

JEE (Advanced)

ADVAY
MAYANK
AIR 36



RUJUL
GARG
AIR 41



ARUSH
ANAND
AIR 64



SHREYAS
LOHIYA
AIR 6
Uttar Pradesh Topper
100 Overall



KUSHAGRA
BAINGAHA
AIR 7
Uttar Pradesh Topper
100 Overall



HARSSH
A GUPTA
AIR 15
Telangana Topper
100 Overall



PHYSICS

SECTION - A

Multiple Choice Questions: This section contains 20 multiple choice questions. Each question has 4 choices (1), (2), (3) and (4), out of which **ONLY ONE** is correct.

Choose the correct answer:

1. Radius of a soap bubble is increased from 1 cm to 2 cm. Work done in process is (S is surface tension)

- (1) $\pi S \times 10^{-2}$ (2) $1.2 \pi S J$
- (3) $2.4 \pi \times 10^{-3} J$ (4) $\pi S \times 10^{-3} J$

Answer (3)

Sol. $W = \Delta U = 2 \cdot S \left\{ 4\pi \left(\frac{2}{100} \right)^2 - \left(\frac{1}{100} \right)^2 \right\}$

$$= \frac{2 \times 4\pi S \times 3}{10^4}$$

$$= 2.4 \pi S \times 10^{-3}$$

2. A rod is placed along principal axis as shown. Find length of image

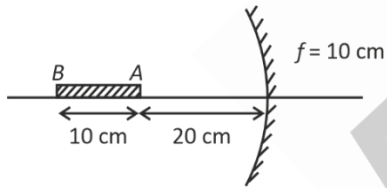

- (1) 10 cm (2) 5 cm
- (3) 15 cm (4) 20 cm

Answer (2)

Sol. Image of A will be at A only as it is center of curvature

For B

$$\frac{1}{v} + \frac{1}{u} = \frac{1}{f}$$

$$\Rightarrow \frac{1}{v} = \frac{1}{f} - \frac{1}{u}$$

$$\Rightarrow \frac{1}{v} = \frac{-1}{10} + \frac{1}{30}$$

$$\Rightarrow \frac{1}{v} = \frac{-3+1}{30}$$

$$v = -15 \text{ cm}$$

\therefore Length of image will be 5 cm.

3. Nuclei A and B form a nucleus C. BE/N for A, B and C are 3 MeV, 7 MeV and 6 MeV. Then energy produced in

$$2A^3 + B^4 \rightarrow C^{10}$$

- (1) 8 MeV (2) 12 MeV
- (3) 14 MeV (4) 10 MeV

Answer (3)

Sol. $\Delta E = 10 \times 6 - (2 \times 3 \times 3) - (4 \times 7)$

$$= 60 - 18 - 28$$

$$= 60 - 46 = 14$$

4. Find coefficient of friction if time taken by block in rough surface is 50% more than time taken by smooth surface. The distance slide by the mass is same in both the cases.

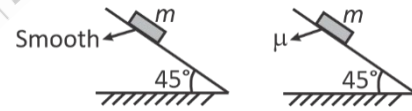

- (1) $\mu = \frac{5}{7}$ (2) $\mu = \frac{5}{9}$
- (3) $\mu = \frac{4}{7}$ (4) $\mu = \frac{4}{9}$

Answer (2)

Sol. $\frac{1}{2} g \frac{1}{\sqrt{2}} t_1^2 = s$

$$\Rightarrow t_1^2 = \frac{2\sqrt{2}s}{g} \quad \dots(i)$$

Our Problem *Solvers* shine bright in **JEE 2025**

JEE (Advanced)				JEE (MAIN)			
ADVAY MAYANK AIR 36	RUJUL GARG AIR 41	ARUSH ANAND AIR 64	SHREYAS LOHIYA AIR 6 Uttar Pradesh Topper 100	KUSHAGRA BAINGAHA AIR 7 Uttar Pradesh Topper 100	HARSSH A GUPTA AIR 15 Telangana Topper 100		

And $\frac{\left(\frac{mg}{\sqrt{2}} - \frac{\mu mg}{\sqrt{2}}\right)}{m} = a_2$

$\frac{1}{2} a_2 t_2^2 = s$

Also $t_2 = \left(\frac{3}{2} t_1\right)$

So $t_2^2 = \frac{2s \cdot \sqrt{2}}{g(1-\mu)} \dots (ii)$

$\frac{9}{4} t_1^2 = \frac{2\sqrt{2}s}{g(1-\mu)} = \frac{9}{4} \cdot \frac{2\sqrt{2}s}{g}$

$\Rightarrow \frac{9}{4} = \frac{1}{1-\mu} \Rightarrow 9 - 9\mu = 4$

$\Rightarrow \frac{5}{9} = \mu$

5. Inputs of A and B are given. Find output result Y of the circuit

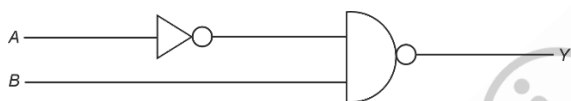

- (1) $A + \bar{B}$ (2) $\bar{A} + B$
(3) $\bar{A} B$ (4) $A \cdot \bar{B}$

Answer (1)

Sol. $Y = \bar{A} \cdot B$

$\Rightarrow Y = \bar{A} + \bar{B} = (A + B)$

6. A uniform sphere of mass m and radius R is divided into two equal parts one part of sphere has moment inertia I_1 about diameter and moment of inertia of disc of radius $2R$ and mass m about perpendicular axis through its center is

I_2 . Find $\frac{I_2}{I_1}$

- (1) 10 (2) 2
(3) 5 (4) 1

Answer (1)

Sol. $I_2 = \frac{m(2R)^2}{2} = 2mR^2$

and $I_1 = \frac{2}{5} \frac{m}{2} R^2 = \frac{mR^2}{5}$

$\frac{I_2}{I_1} = 10$

7. For the circuit given below, find the V_{AB} and i_{AB} .

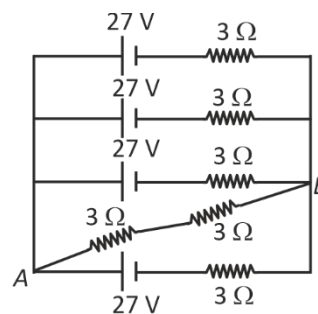

- (1) 18 V, 8 A (2) 18 V, 6 A
(3) 24 V, 3 A (4) 24 V, 4 A

Answer (4)

Sol. $\frac{1}{r_0} = \frac{1}{3} + \frac{1}{3} + \frac{1}{3} + \frac{1}{3} = \frac{4}{3}$

$\Rightarrow r_0 = \frac{3}{4} \Omega$

And $\epsilon_0 = \frac{\epsilon(r)^3 \times 4}{4(r)^3} = \epsilon = 27 \text{ volts}$

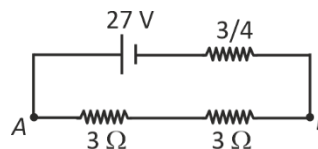

So $i_{AB} = \frac{27 \times 4}{27} = 4 \text{ Ampere}$

And $V_{AB} = 4 \times 6 = 24 \text{ volts}$

Our Problem *Solvers* shine bright in **JEE 2025**

JEE (Advanced)

ADVAY
MAYANK
AIR 36



RUJUL
GARG
AIR 41



ARUSH
ANAND
AIR 64



SHREYAS
LOHIYA
AIR 6
Uttar Pradesh Topper
100 Overall



KUSHAGRA
BAINGAHA
AIR 7
Uttar Pradesh Topper
100 Overall



HARSSH
A GUPTA
AIR 15
Telangana Topper
100 Overall



8. A system of two composite wire is having a mass 8 kg attached with it as shown in figure. For wire (1) $y_1 = 2 \times 10^{11}$ N/m², $r_1 = 2$ mm, and $l_1 = 0.314$ m. And for wire (2) $y_2 = 4 \times 10^{11}$ N/m², $r_2 = 2$ mm, $l_2 = 0.628$ m.

Find total tension in the wires.

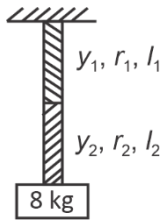

[$y \rightarrow$ Youngs modulus, $r \rightarrow$ radius, $l \rightarrow$ length]

- (1) 4×10^{-5} m (2) 4×10^{-4} m
(3) 2×10^{-5} m (4) 2×10^{-4} m

Answer (3)

Sol.
$$\Delta l = \frac{F_1 l_1}{A_2 y_1} + \frac{F_2 l_2}{A_2 y_2}$$

$$\Rightarrow \Delta l = \frac{mg}{\pi r^2} \left[\frac{l_1}{y_1} + \frac{l_2}{y_2} \right]$$

$$\Rightarrow \Delta l = \frac{8 \times 10}{3.14 \times 4 \times 10^{-6}} \left[\frac{0.314}{2 \times 10^{11}} + \frac{0.628}{4 \times 10^{11}} \right]$$

$$\Rightarrow \Delta l = \frac{8 \times 10}{3.14 \times 4 \times 10^{-6}} \times \frac{2 \times 0.314}{2 \times 10^{11}} = 2 \times 10^{-5} \text{ m}$$

9. There are two samples of gases :

Sample A \rightarrow Number of moles is 2 and volume is $3 V_0$

Sample B \rightarrow Number of moles is 2 and volume is V_0

If relation between pressure and volume for both

samples is $P = \frac{P_0}{\left(1 + \left(\frac{V}{V_0}\right)^2\right)}$.

Then find difference between temperature of sample B and sample A

- (1) $\frac{P_0 V_0}{10R}$ (2) $\frac{P_0 V_0}{R}$
(3) $\frac{P_0 V_0}{20R}$ (4) $\frac{P_0 V_0}{8R}$

Answer (1)

Sol.
$$P_A = \frac{P_0}{1+9} = \frac{P_0}{10}$$

$$P_B = \frac{P_0}{2}$$

$$\Rightarrow T_B = \frac{\frac{P_0}{2} V_0}{2R} = \frac{P_0 V_0}{4R}$$

$$T_A = \frac{\frac{P_0}{10} \times 3V_0}{2R} = \frac{3P_0 V_0}{20R}$$

$$T_B - T_A = \frac{5P_0 V_0 - 3P_0 V_0}{20R}$$

$$\Rightarrow \frac{P_0 V_0}{10R}$$

10. A spiral coil having total 200 turns, inner radius 3 cm and outer radius 6 cm has 20 mA current through it. Find its magnetic moment.

- (1) $42\pi \times 10^{-4}$ Am² (2) $36\pi \times 10^{-3}$ Am²
(3) $84\pi \times 10^{-4}$ Am² (4) $27\pi \times 10^{-4}$ Am²

Answer (3)

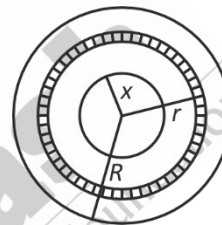

Sol.

$$\int dM = \int dr \pi r^2$$

$$M = \int \frac{N dr i \pi r^2}{(R-x)}$$

$$\Rightarrow \frac{Ni}{R-x} \pi \left[\frac{r^3}{3} \right]_x^R$$

$$\Rightarrow \frac{Ni\pi}{3(R-x)} (R^3 - x^3)$$

$$\Rightarrow \frac{Ni\pi}{3} (R^2 + Rx + x^2)$$

$$\Rightarrow \frac{200}{3} \times 20 \times 10^{-3} \pi (36 + 18 + 9) \times 10^{-4}$$

$$84\pi \times 10^{-4}$$

Our Problem Solvers shine bright in **JEE 2025**

JEE (Advanced)

ADVAY
MAYANK
AIR 36



RUJUL
GARG
AIR 41



ARUSH
ANAND
AIR 64



JEE (MAIN)

SHREYAS
LOHIYA
AIR 6
Uttar Pradesh Topper
100



KUSHAGRA
BAINGAHA
AIR 7
Uttar Pradesh Topper
100



HARSSH
A GUPTA
AIR 15
Telangana Topper
100



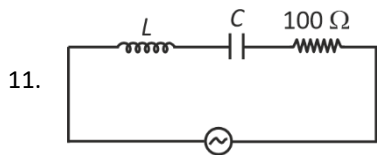

Power factor of the above circuit is 0.5. Find $|X_L - X_C|$.

(take $\sqrt{3} = 1.73$)

- (1) 346 W (2) 173 W
(3) 86.5 W (4) 58 W

Answer (2)

Sol. $\cos\phi = 0.5$

$\phi = 60^\circ$

$\tan 60^\circ = \frac{X_L - X_C}{R}$

$\Rightarrow \sqrt{3} = \frac{|X_L - X_C|}{100}$

$\Rightarrow |X_L - X_C| = 173$

12. Electric field of EMW is given as $\vec{E} = (E_1\hat{i} + E_2\hat{k}) \sin(kx + kz - \omega t)$. Find reflected ray equation if θ is Brewster angle

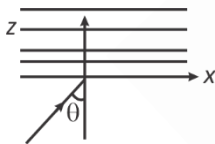

(1) $(E_1\hat{i} + E_2\hat{k})$

$\sin(kx + kz - \omega t)$

(2) $E_1\hat{i} + E_2\hat{k}$

$\sin(kx - kz - \omega t)$

(3) $E_0\hat{j} \sin(kx + kz - \omega t)$

(4) $E_0\hat{j} \sin(kx - kz - \omega t)$

Answer (4)

Sol. If $\hat{i} = x\hat{i} + z\hat{k}$

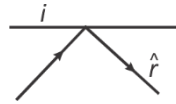

then $\hat{r} = x\hat{i} - z\hat{k}$

& \vec{E} in $(\hat{i} \& \hat{k})$ is null because of polarization.

Only transverse component of electric field will be reflected. So only (E_1) . And the direction of propagation in z direction will be reversed.

13. A telescope has resolving power of 5×10^{-7} radian. The wavelength of light is 500 nm. Find diameter of telescope. (in fermi meter)

- (1) 112 (2) 224
(3) 61 (4) 305

Answer (4)

Sol. Resolving Power = $\frac{D}{1.22\lambda}$

$\Rightarrow D = 1.22 \lambda \times R$

$\Rightarrow D = 1.22 \times 5 \times 10^{-7} \times 500 \times 10^{-9}$

$\Rightarrow D = 25 \times 1.22 \times 10^{-14} \text{ m}$

$D = 305 \times 10^{-15} \text{ m}$

$D = 305 \text{ m}$

14. Two forces \vec{F}_1 and \vec{F}_2 act simultaneously on a body $\vec{F}_1 = 3\hat{i} + 5\hat{j}$ and $\vec{F}_2 = 2\hat{i} - 4\hat{j} + 2\hat{k}$ and body is displaced by 25 cm along $3\hat{i} - 4\hat{j}$ find work done by net force.

- (1) 55 J (2) 60 J
(3) 70 J (4) 86 J

Answer (1)

Sol. $\vec{F}_{\text{net}} = \vec{F}_1 + \vec{F}_2 = 5\hat{i} + \hat{j} + 2\hat{k}$

$w = \vec{F} \cdot \vec{S} = FS \cos\theta$

$w = (5\hat{i} + \hat{j} + 2\hat{k}) \cdot \frac{(3\hat{i} - 4\hat{j})}{5} \times 25$

$w = (15 - 4) \times 5$

$w = 55 \text{ J}$

Our Problem Solvers shine bright in **JEE 2025**

JEE (Advanced)

ADVAY
MAYANK
AIR 36



RUJUL
GARG
AIR 41



ARUSH
ANAND
AIR 64



SHREYAS
LOHIYA
AIR 6
Uttar Pradesh Topper
100



KUSHAGRA
BAINGAHA
AIR 7
Uttar Pradesh Topper
100



HARSSH
A GUPTA
AIR 15
Telangana Topper
100



15. In single slit diffraction, distance between third minima & 1st minima is (a is slit width, D is distance of screen & λ is wavelength)

- (1) $\frac{3\lambda D}{a}$ (2) $\frac{4\lambda D}{a}$
 (3) $\frac{2\lambda D}{a}$ (4) $\frac{\lambda D}{2a}$

Answer (3)

Sol. $a\theta = n\lambda$ for minima

$$\theta_1 = \frac{\lambda}{a}, \quad \theta_2 = \frac{3\lambda}{a}$$

$$\text{Distance} = D\Delta\theta = D \frac{2\lambda}{a}$$

16. Bulk modulus of water is 2.2×10^9 Pa. At depth 220 m find % change in density (w.r.t the density at the surface).

- (1) 0.1%
 (2) 1%
 (3) 0.2%
 (4) 2%

Answer (1)

Sol. $dp = \rho gh$

$$\frac{dv}{v} = \left| \frac{d\rho}{\rho} \right|$$

$$\text{Also } dp = \left| \frac{dv}{v} \right| B$$

$$\text{So } d_p = \left(\frac{d\rho}{\rho} \right) \times B = \rho gh$$

$$\Rightarrow \left(\frac{d\rho}{\rho} \right) \times 100 = \left(\frac{\rho gh}{\beta} \right) \times 100$$

$$= \frac{1000 \times 10 \times 220 \times 100}{2.2 \times 10^9} = 0.1\%$$

17.
 18.
 19.
 20.

SECTION - B

Numerical Value Type Questions: This section contains 5 Numerical based questions. The answer to each question should be rounded-off to the nearest integer.

21. If resistance of diode in forward bias is 10Ω then time constant of the circuit would be $\alpha \times 10^{-5}$. Find α .

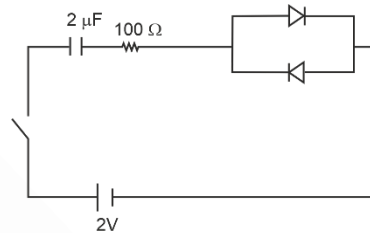

Answer (22)

Sol. $\tau : RC$

$$\tau = 110 \times 2 \times 10^{-6}$$

$$\Rightarrow \tau = 22 \times 10^{-5}$$

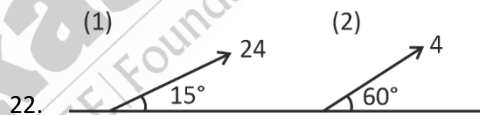

22. Range of projectile (1) is N times

Range of projectile (2) then $\sqrt{3}N$ is

Answer (4)

$$\text{Sol. } R = \frac{u^2 \sin 2\theta}{g}$$

$$\frac{R_1}{R_2} = 4 \times \frac{\sin 30}{\sin 120} = \frac{2 \times 2}{\sqrt{3}} = \frac{4}{\sqrt{3}}$$

23.
 24.
 25.

Our Problem *Solvers* shine bright in **JEE 2025**

JEE (Advanced)

ADVAY
MAYANK
AIR 36



RUJUL
GARG
AIR 41



ARUSH
ANAND
AIR 64



JEE (MAIN)

SHREYAS
LOHIYA
AIR 6
Uttar Pradesh Topper
100 Overall



KUSHAGRA
BAINGAHA
AIR 7
Uttar Pradesh Topper
100 Overall



HARSSH
A GUPTA
AIR 15
Telangana Topper
100 Overall



CHEMISTRY

SECTION - A

Multiple Choice Questions: This section contains 20 multiple choice questions. Each question has 4 choices (1), (2), (3) and (4), out of which **ONLY ONE** is correct.

Choose the correct answer :

- Statement I : BP order is $HI < HBr < HCl < HF$.
Statement II : MP order is $HI < HF < HCl < HBr$.
(1) Statement I and Statement II are correct
(2) Statement I is correct and Statement II is wrong
(3) Statement I is wrong and Statement II is correct
(4) Statement I wrong and Statement II is correct

Answer (3)

Sol.	BP (K)	MP (K)
HF	293	190
HCl	189	159
HBr	206	185
HI	238	222

- Consider the following reaction

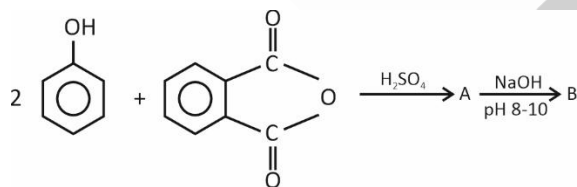

The color of the compound(B) formed is

- Violet
- Red
- Colourless
- Pink

Answer (4)

Sol.

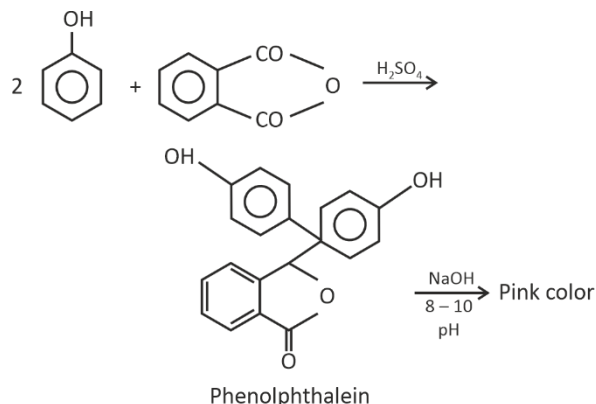

- Given below are two statements :

Statement I : Maltose is a non-reducing sugar

Statement II : Lactose is a reducing sugar

- Both statement I and statement II are correct
- Statement I is correct but statement II is incorrect
- Statement I is incorrect but statement II is correct
- Both statement I and statement II are incorrect

Answer (3)

Sol. Maltose \rightarrow 2 units of α -D-glucose ($C_1 - C_4$ glycosidic linkage)

Lactose \rightarrow β -D-galactose + β -D-glucose

Both are reducing sugar

- If the wavelength of first line of Balmer series and of Brackett series of Hydrogen atom are respectively λ_1 and λ_2 respectively, then value of $\frac{\lambda_1}{\lambda_2}$ is

- 0.16
- 0.04
- 0.28
- 0.35

Answer (1)

Sol. $\frac{1}{\lambda_1} = R \times 1^2 \times \left(\frac{1}{2^2} - \frac{1}{3^2} \right) = \frac{5R}{36}$, $\lambda_1 = \frac{36}{5R}$

Our Problem *Solvers* shine bright in **JEE 2025**

JEE (Advanced)

ADVAY
MAYANK
AIR 36



RUJUL
GARG
AIR 41



ARUSH
ANAND
AIR 64



JEE (MAIN)

SHREYAS
LOHIYA
AIR 6
Uttar Pradesh Topper
100 Overall



KUSHAGRA
BAINGAHA
AIR 7
Uttar Pradesh Topper
100 Overall



HARSSH
A GUPTA
AIR 15
Telangana Topper
100 Overall



$$\frac{1}{\lambda_2} = R \times 1^2 \times \left(\frac{1}{4^2} - \frac{1}{5^2} \right) = \frac{9R}{400}, \lambda_2 = \frac{400}{9R}$$

$$\frac{\lambda_1}{\lambda_2} = \frac{36}{5R} \times \frac{9R}{400} = 0.16$$

5. What will be the pH at 25°C of solution obtained by mixing of 100 mL, 0.5 M NH₄OH solution and 0.01 M, 25 mL NH₄Cl solution? (pK_b of NH₃ = 4.74)

- (1) 11.56 (2) 9.0
(3) 2.44 (4) 4.5

Answer (1)

Sol. After mixing :

$$[\text{NH}_4\text{OH}] = \frac{50}{125} \text{ M}$$

$$[\text{NH}_4\text{Cl}] = \frac{0.25}{125} \text{ M}$$

Solution acts as buffer solution

$$\text{pOH} = \text{pK}_b + \log \frac{0.25}{50}$$

$$\text{pOH} = 4.74 - 2.3 = 2.44$$

$$\text{pH} = 14 - 2.44 = 11.56$$

6. Match the following

	Species		Magnetic moment (BM)
(I)	Mn ²⁺	(P)	$\sqrt{24}$
(II)	Co ²⁺	(Q)	$\sqrt{35}$
(III)	Cu ²⁺	(R)	$\sqrt{15}$
(IV)	Cv ²⁺	(S)	$\sqrt{3}$

- (1) (i) → (Q), (ii) → (R), (iii) → (S), (iv) → (P)
(2) (i) → (R), (ii) → (S), (iii) → (P), (iv) → (Q)
(3) (i) → (P), (ii) → (Q), (iii) → (R), (iv) → (S)
(4) (i) → (S), (ii) → (Q), (iii) → (P), (iv) → (R)

Answer (1)

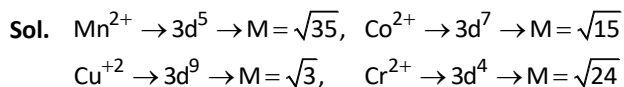

7. Match the following :

	List-I (Amino Acid)		List-II (Single letter code)
(I)	Arginine	(P)	D
(II)	Lysine	(Q)	K
(III)	Glutamic acid	(R)	E
(IV)	Aspartic acid	(S)	R

Choose the correct option

- (1) (I)-(S), (II)-(Q), (III)-(P), (IV)-(R)
(2) (I)-(Q), (II)-(S), (III)-(P), (IV)-(R)
(3) (I)-(S), (II)-(Q), (III)-(R), (IV)-(P)
(4) (I)-(P), (II)-(Q), (III)-(R), (IV)-(S)

Answer (3)

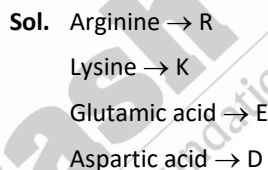

8. Given

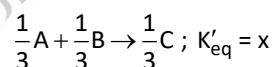

The value of x is

- (1) 9×10^{-6} (2) 3×10^{-2}
(3) 2.7×10^{-5} (4) 4×10^{-2}

Answer (2)

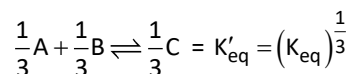
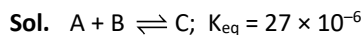

$$K'_{\text{eq}} = 3 \times 10^{-2}$$

Our Problem Solvers shine bright in **JEE 2025**

JEE (Advanced)

ADVAY
MAYANK
AIR 36



RUJUL
GARG
AIR 41



ARUSH
ANAND
AIR 64



JEE (MAIN)

SHREYAS
LOHIYA
AIR 6
Uttar Pradesh Topper
100 Overall



KUSHAGRA
BAINGAHA
AIR 7
Uttar Pradesh Topper
100 Overall



HARSSH
A GUPTA
AIR 15
Telangana Topper
100 Overall



Sol. $K_3[Fe(OH)_6] \Rightarrow Fe^{3+} \Rightarrow 3d^5 \Rightarrow n = 5$

$$\mu = \sqrt{35} \text{ BM} = 5.92 \text{ BM}$$

$K_4[Fe(OH)_6] \Rightarrow Fe^{2+} \Rightarrow 3d^6 \Rightarrow n = 4$

$$\mu = \sqrt{24} \text{ BM} = 4.90 \text{ BM}$$

14. Arrange the following functional groups in increasing order of electron withdrawing effect.

-CN ; -NO₂ ; -I ; -COOH

(1) -NO₂ < -CN < -I < -COOH

(2) -I < -COOH < -CN < -NO₂

(3) -COOH < -I, -NO₂ < -CN

(4) -I < -COOH < -NO₂ < -CN

Answer (2)

Sol. Order of electron withdrawing :

-I < -COOH < -CN < -NO₂

15. The number of moles of F₂C₂O₄ and FeSO₄ · (NH₄)₂SO₄ · 6H₂O required to completely react with 2 mol of acidified KMnO₄ for each of them is respectively

(1) 3.33 moles and 10 moles

(2) 5 moles and 10 moles

(3) 5 moles and 3.33 moles

(4) 3.33 moles and 5 moles

Answer (1)

Sol. Equivalents of KMnO₄ = Equivalents of FeC₂O₄

$$2 \times 5 = \text{mol of FeC}_2\text{O}_4 \times (1 + 2)$$

$$\text{Mol of FeC}_2\text{O}_4 = \frac{10}{3} = 3.33$$

Equivalents of KMnO₄ = Equivalents of FeSO₄ · (NH₄)₂SO₄ · 6H₂O

$$2 \times 5 = 1 \times \text{mol of FeSO}_4 \cdot (\text{NH}_4)_2\text{SO}_4 \times 6\text{H}_2\text{O} = 10$$

16. Consider the following reaction

P → Q

If the reaction follows first order kinetics, find the fraction of decomposed molecule at time t

(1) 1 - e^{kt}

(2) 1 + e^{kt}

(3) 1 - e^{-kt}

(4) 1 + e^{-kt}

Answer (3)

Sol. [At] = [A₀] e^{-kt}

Amount decomposed = [A₀] - [At]

$$= [A_0] - [A_0] e^{-kt}$$

$$= [A_0] (1 - e^{-kt})$$

$$\text{Fraction decomposed} = \frac{[A_0](1 - e^{-kt})}{[A_0]} = 1 - e^{-kt}$$

17. 4 g of solute is dissolved in a certain amount of solvent and its vapour pressure decreases from 760 mm to 750 mm. 4 gram of same solute is dissolved in same amount of that solvent that causes increase in boiling point by 0.15°C. Calculate the molar mass of solvent. [K_b = 0.5 K kg/mol]. Consider solute to be non-electrolyte.

(1) 22.22 g/mol

(2) 44.44 g/mol

(3) 60 g/mol

(4) 70 g/mol

Answer (2)

$$\text{Sol. } \frac{P^\circ - P_s}{P_s} = \frac{n}{N}$$

$$\frac{760 - 750}{750} = \frac{n}{N}$$

$$\frac{30}{750} = \frac{n}{N}$$

$$\frac{n}{N} = \frac{1}{75}$$

$$\Delta T_b = m \times K_b$$

$$0.15 = m \times 0.5$$

$$m = 0.3$$

$$m = \frac{W \times 1000}{M_2 \times W} = \frac{n \times 1000}{W}$$

$$M = \frac{n \times 1000}{N \times M_1}$$

$$0.3 = \frac{1}{75} \times \frac{1000}{M_1}$$

Our Problem Solvers shine bright in **JEE 2025**

JEE (Advanced)

ADVAY
MAYANK
AIR 36



RUJUL
GARG
AIR 41



ARUSH
ANAND
AIR 64



SHREYAS
LOHIYA
AIR 6
Uttar Pradesh Topper
100 Overall



KUSHAGRA
BAINGAHA
AIR 7
Uttar Pradesh Topper
100 Overall



HARSSH
A GUPTA
AIR 15
Telangana Topper
100 Overall



$$M_1 = \frac{10,000}{75 \times 3}$$

$$M_1 = 44.4 \text{ g/mol}$$

18. An organic compound on reductive ozonolysis gives the following products

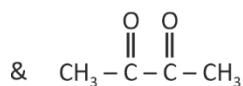
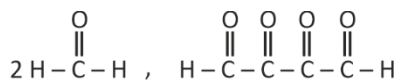

The structure of organic compound is

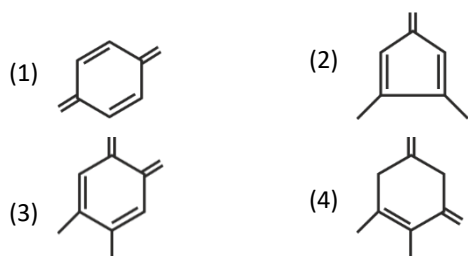

Answer (3)

Sol.

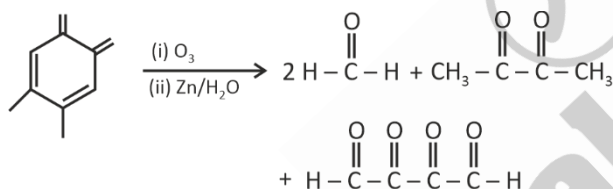

19. 112 dm^3 of SO_2 is given at STP. The number of moles and number of molecules of SO_2 respectively are

- (1) 0.5, 30.11×10^{24} (2) 5, 3.011×10^{24}
 (3) 8, 3.011×10^{23} (4) 8, 6.022×10^{24}

Answer (2)

Sol. Number of moles of $\text{SO}_2 = \frac{112}{22.4} = 5$ moles

Number of molecules of $\text{SO}_2 = 5 \times 6.022 \times 10^{23}$
 $= 3.011 \times 10^{24}$

20.

SECTION - B

Numerical Value Type Questions: This section contains 5 Numerical based questions. The answer to each question should be rounded-off to the nearest integer.

21. Total number of lone pairs and sigma (σ) bond pairs formed by central atom (Xe) in XeO_6^{4-}

Answer (6)

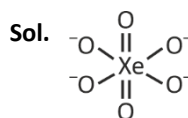

Number of lone pair on Xe = 0

Number of σ bond pair = 6

22. Consider the reaction,

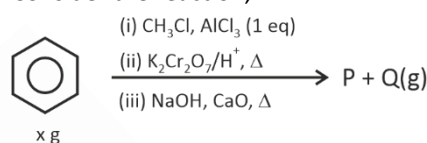

If volume of Q(g) is 0.112 dm^3 at STP. Find value of $10(x)$ (Nearest integer).

(Mass of benzene taken initially = $x \text{ g}$)

Answer (4)

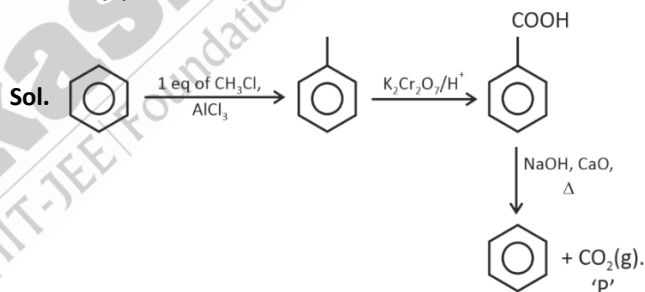

Volume = 0.112 dm^3

$$n_{\text{CO}_2} = \frac{0.112}{22.4} = 5 \times 10^{-3} = n_{\text{benzene}}$$

Mass of benzene (M) = $5 \times 10^{-3} \times 78$

0.39 g

23.

24.

25.

Our Problem Solvers shine bright in **JEE 2025**

JEE (Advanced)

ADVAY
MAYANK
AIR 36



RUJUL
GARG
AIR 41



ARUSH
ANAND
AIR 64



JEE (MAIN)

SHREYAS
LOHIYA
AIR 6
Uttar Pradesh Topper
100 Overall



KUSHAGRA
BAINGAHA
AIR 7
Uttar Pradesh Topper
100 Overall



HARSH
A GUPTA
AIR 15
Telangana Topper
100 Overall



MATHEMATICS

SECTION - A

Multiple Choice Questions: This section contains 20 multiple choice questions. Each question has 4 choices (1), (2), (3) and (4), out of which **ONLY ONE** is correct.

Choose the correct answer :

1. If z be a complex number such that $|z + 2| = |z - 2|$ and

$$\arg\left(\frac{z-3}{z+i}\right) = \frac{\pi}{4} \text{ then the value of } |z|^2 \text{ is}$$

- (1) 9 (2) 3
(3) 2 (4) 4

Answer (1)

Sol. $|z - 2| = |z + 2|$

$\Rightarrow z$ lie on y -axis

$$\arg\left(\frac{z-3}{z+i}\right) = \arg\left(\frac{3-z}{-i-z}\right) = \frac{\pi}{4} \text{ represent}$$

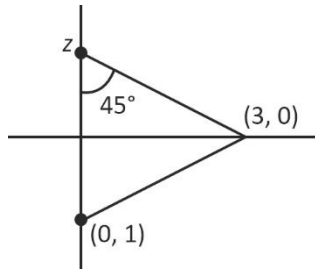

$\Rightarrow z = 3i$ is the only one solution

2. Let A is a matrix of order 3 such that $|A| = -4$. Then, the value of $|adj(adj(2adj(A))^{-1})|$ is

- (1) $\frac{1}{2^{16}}$ (2) $\frac{1}{2^{28}}$
(3) $\frac{1}{2^{30}}$ (4) $\frac{1}{2^{20}}$

Answer (2)

Sol. $|adj(adj(2adj(A))^{-1})| = |(2adj(A)^{-1})|^2$

$$\begin{aligned} &= \frac{1}{|2adj(A)|^4} \\ &= \frac{1}{2^{12} |adj(A)|^4} \\ &= \frac{1}{2^{12} |A|^8} \\ &= \frac{1}{2^{12} \times (-4)^8} = \frac{1}{2^{28}} \end{aligned}$$

3. The number of ways 4 boys and 3 girls are to be arranged in a row so that all 3 girls are not together, is equal to

- (1) 2320 (2) 4320
(3) 4920 (4) 1440

Answer (2)

Sol. \Rightarrow Total ways = $7!$

We need to remove cases where all 3 girls are together.

$$\begin{aligned} \Rightarrow & \boxed{G_1 G_2 G_3} B_1 B_2 B_3 B_4 \\ \Rightarrow & 3! \times 5! \\ \Rightarrow & \text{Required ways} = 7! - 3! \times 5! \\ & = 4320 \end{aligned}$$

4. $y = \tan^{-1}\left(\frac{3\cos x - 4\sin x}{4\cos x + 3\sin x}\right) + \tan^{-1}\left(\frac{x}{1 + \sqrt{1+x^2}}\right)$, then

find $\frac{dy}{dx}$ at $x = \frac{\sqrt{3}}{2}$

- (1) $\frac{5}{7}$ (2) $\frac{-5}{7}$
(3) $\frac{3}{7}$ (4) $\frac{-3}{2}$

Answer (2)

Our Problem *Solvers* shine bright in **JEE 2025**

JEE (Advanced)			JEE (MAIN)		
ADVAY MAYANK AIR 36	RUJUL GARG AIR 41	ARUSH ANAND AIR 64	SHREYAS LOHIYA AIR 6 Uttar Pradesh Topper 100 Overall	KUSHAGRA BAINGAHA AIR 7 Uttar Pradesh Topper 100 Overall	HARSH A GUPTA AIR 15 Telangana Topper 100 Overall

Sol.

$$\tan^{-1}\left(\frac{3\cos x - 4\sin x}{4\cos x + 3\sin x}\right) + \tan^{-1}\left(\frac{x}{1 + \sqrt{1+x^2}}\right)$$

$$\tan^{-1}\left(\frac{\frac{3}{4} - \tan x}{1 + \frac{3}{4}\tan x}\right) + \tan^{-1}\left(\frac{\tan \phi}{1 + \sec \phi}\right) \text{ {put } x = \tan \phi}$$

$$\tan^{-1}(\tan(A-x)) + \tan^{-1}\left(\frac{\sin \phi}{1 + \cos \phi}\right)$$

$$(A-x) + \tan^{-1}\left(\frac{2\sin\frac{\phi}{2}\cos\frac{\phi}{2}}{2\cos^2\frac{\phi}{2}}\right)$$

$$(A-x) + \tan^{-1}\left(\tan\frac{\phi}{2}\right)$$

$$\therefore y = (A-x) + \frac{\phi}{2} = (A-x) + \frac{1}{2}\tan^{-1}x$$

$$\frac{dy}{dx} = -1 + \frac{1}{2} \cdot \frac{1}{1+x^2}$$

$$\frac{dy}{dx}\bigg|_{x=\frac{\sqrt{3}}{2}} = -1 + \frac{1}{2} \cdot \frac{1}{1+\frac{3}{4}} = \frac{-5}{7}$$

5. The domain of the function $\cos^{-1}\left\{\frac{4\pi+2[x]}{3}\right\}$, where $[\cdot]$ is greatest integer function, is

(1) $\left[0, \frac{3}{4}\right]$ (2) $\left[\frac{-1}{4}, \frac{1}{4}\right]$

(3) $\left[\frac{-1}{4}, \frac{3}{4}\right]$ (4) $\left[\frac{-3}{4}, \frac{1}{4}\right]$

Answer (3)

Sol. $\cos^{-1}(t)$ is defined for $t \in [-1, 1]$

$$\Rightarrow \frac{4x+2[x]}{3} \in [-1, 1]$$

$$\Rightarrow -3 \leq 4x + 2[x] \leq 3$$

- (i) If $x \geq 1$

$$\Rightarrow [x] \geq 1$$

$$\Rightarrow 4x + 2[x] \geq 6$$

Not is not required

- (ii) If $0 \leq x < 1$

$$\Rightarrow [x] = 0$$

$$\Rightarrow -3 \leq 4x \leq 3 \Rightarrow \frac{-3}{4} \leq x \leq \frac{3}{4}$$

$$\Rightarrow x \in \left[0, \frac{3}{4}\right]$$

- (iii) If $-1 \leq x < 0$

$$\Rightarrow [x] = -1$$

Then $- \leq 4x \leq 5$

$$\Rightarrow x \in \left[\frac{-1}{4}, \frac{5}{4}\right]$$

$$\Rightarrow x \in \left[\frac{-1}{4}, 0\right)$$

Similarly, if $x < -1 \Rightarrow [x] \leq -2$

\Rightarrow no such solution

$$\Rightarrow x \in \left[\frac{-1}{4}, \frac{3}{4}\right]$$

6. Let S_n is the sum of first n terms of an A.P and a_n is the n^{th} term of A.P. If first term of the given A.P is $\frac{10}{3}$ and

$S_{30} = a_{30}^3$. Then, the common difference of the given A.P is

(1) $\frac{5}{87}$ (2) $\frac{5}{83}$

(3) $\frac{4}{87}$ (4) $\frac{3}{83}$

Answer (1)

$$\text{Sol. } S_{30} = \frac{30}{2} \left[2\left(\frac{10}{3}\right) + (30-1)d \right] = 15 \left[\frac{20}{3} + 29d \right]$$

$$a_{30} = \frac{10}{3} + (30-1)d$$

Our Problem Solvers shine bright in **JEE 2025**

JEE (Advanced)

ADVAY
MAYANK
AIR 36



RUJUL
GARG
AIR 41



ARUSH
ANAND
AIR 64



SHREYAS
LOHIYA
AIR 6
Uttar Pradesh Topper
100 Overall



KUSHAGRA
BAINGAHA
AIR 7
Uttar Pradesh Topper
100 Overall



HARSH
A GUPTA
AIR 15
Telangana Topper
100 Overall



9. Let $P(1, 2)$ be any point from which two chords bisected at y -axis are drawn to the circle whose equation is $x^2 + y^2 + x - 6y = 0$. Then, a equation of the chord is

- (1) $(1 + \sqrt{3})x + 2y - (5 + \sqrt{3}) = 0$
- (2) $(1 + \sqrt{3})x - 2y + (5 + \sqrt{3}) = 0$
- (3) $(1 - \sqrt{3})x + 2y + (5 + \sqrt{3}) = 0$
- (4) $(1 - \sqrt{3})x - 2y + (5 + \sqrt{3}) = 0$

Answer (1)

Sol. Let chords are bisected at $M(0, y)$ equation of chord is $T = S_1$

$$\Rightarrow x \times 0 + y \times y_1 + \frac{1}{2}(x+0) - 3(y+y_1) = y_1^2 - 6y_1$$

passes through $p(1, 2)$

$$\Rightarrow 2y_1 + \frac{1}{2} - 3(2+y_1) = y_1^2 - 6y_1$$

$$\Rightarrow 4y_1 + 1 - 12 - 6y_1 = 2y_1^2 - 12y_1$$

$$\Rightarrow 2y_1^2 - 10y_1 + 11 = 0$$

$$\Rightarrow y_1 = \frac{10 \pm \sqrt{100 - 88}}{4} = \frac{5 \pm \sqrt{3}}{2}$$

\Rightarrow There are two possible mid-points $M_1\left(0, \frac{5 + \sqrt{3}}{2}\right)$

and $M_2\left(0, \frac{5 - \sqrt{3}}{2}\right)$

\Rightarrow equation of chords PM_1 and PM_2 are $(1 + \sqrt{3})x + 2y - (5 + \sqrt{3}) = 0$ and $(1 - \sqrt{3})x + 2y - (5 - \sqrt{3}) = 0$ respectively.

10. Let $f(x) = f'(x) \cdot f''(x)$ and $f(0) = 0$, where $f(x)$ is a polynomial function of n^{th} degree. The value of

$$36 \left[f'(2) + f''(2) + \int_0^1 f(x) dx \right]$$
 is equal to

- (1) 36
- (2) 40
- (3) 48.5
- (4) 38.5

Answer (3)

Sol. $n = (n - 1) + (n - 2)$

$$\Rightarrow n = 2n - 3$$

$$\Rightarrow n = 3$$

$$f(0) = 0, d = 0$$

$$f(x) = ax^3 + bx^2 + cx$$

$$ax^3 + bx^2 + cx = (3ax^2 + 2bx + c)(6ax + 2b)$$

$$= 18a^2x^3 + x^2(6ab + 12ab) + x(6ac + 4b^2) + 2bc$$

$$a = 18a^2 \Rightarrow a = \frac{1}{18}$$

$$b = 18 \times \frac{1}{18} \times b \Rightarrow b = b$$

Let $c = 0 \Rightarrow b = 0$

$$\therefore f(x) = \frac{x^3}{18}$$

$$\therefore f'(2) = \frac{2}{3}$$

$$f''(2) = \frac{2}{3}$$

$$\int_0^1 f(x) dx = \frac{1}{72}$$

$$\therefore \text{Required Value} = 36 \left[\frac{2}{3} + \frac{2}{3} + \frac{1}{72} \right] = 48.5$$

11. Let $A(-2, -34, 6)$ and lines $L_1 : \frac{x-1}{2} = \frac{y-4}{4} = \frac{z-0}{1}$ and

$L_2 : \frac{x-2}{1} = \frac{y+2}{-4} = \frac{z+2}{3}$. Then, the distance of A from

L_2 measured along L_1 is

- (1) $3\sqrt{21}$
- (2) $4\sqrt{21}$
- (3) $7\sqrt{5}$
- (4) $6\sqrt{7}$

Answer (2)

Sol. Any point on L_2

Our Problem Solvers shine bright in **JEE 2025**

JEE (Advanced)

 ADVAY MAYANK AIR 36	 RUJUL GARG AIR 41	 ARUSH ANAND AIR 64
---	---	--

JEE (MAIN)

 SHREYAS LOHIYA AIR 6 Uttar Pradesh Topper 100 Overall	 KUSHAGRA BAINGAHA AIR 7 Uttar Pradesh Topper 100 Overall	 HARSH A GUPTA AIR 15 Telangana Topper 100 Overall
--	--	---

$$P(K+2, -4K-2, 3K-2)$$

$$\overline{AP} = (K+4, -4K+32, 3K-8)$$

$$\frac{K+4}{2} = \frac{-4K+32}{4} = \frac{3K-8}{1}$$

$$\Rightarrow \frac{K+4}{2} = \frac{3K-8}{1}$$

$$\Rightarrow K+4 = 6K-16$$

$$\Rightarrow 20 = 5K$$

$$\Rightarrow K = 4$$

$$P(6, -18, 10)$$

$$|AP| = \sqrt{(6+2)^2 + (-34+18)^2 + (10-6)^2}$$

$$= \sqrt{64 + 256 + 16}$$

$$= 4\sqrt{21}$$

12. Let $S = \{A : A = \begin{bmatrix} a & b \\ c & d \end{bmatrix}, a, b, c, d \in \{0, 1, 2, 3, 4\},$

$A^2 - 4A + 3I = 0\}$. The number of elements in the set S is equal to

(1) 10 (2) 19

(3) 1 (4) 9

Answer (2)

Sol. $A^2 - 4A + 3I = 0$

$$\Rightarrow \text{tr}(A) = 4, |A| = 3$$

$$a + d = 4, ad - bc = 3$$

$$a, b, c, d \in \{0, 1, 2, 3, 4\}$$

$$a = 0 \Rightarrow d = 4 \Rightarrow bc = -3 \text{ (not possible)}$$

$$a = 1 \Rightarrow d = 3 \Rightarrow bc = 0 \text{ (9 cases)}$$

$$a = 2 \Rightarrow d = 2 \Rightarrow bc = -1 \text{ (1 case)}$$

$$a = 3 \Rightarrow d = 1 \Rightarrow bc = 0 \text{ (9 cases)}$$

$$a = 4 \Rightarrow d = 0 \Rightarrow bc = -3 \text{ (not possible)}$$

Total = 19 cases

13. Let A, B and C be vertices of a triangle such that $A(1, 2)$ and mid point of AB is $(3, 4)$ and centroid is $(5, 7)$. If the vertices of circumcentre of $\triangle ABC$ is (α, β) then $12(\alpha + \beta)$ is

(1) 72 (2) 84

(3) 64 (4) 81

Answer (2)

Sol.

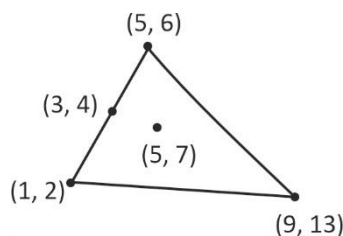

\Rightarrow we can find vertices of Δ as $5 = \frac{1+5+9}{3}$ and

$$7 = \frac{2+6+13}{3}$$

Now, to find circumcentre

$$(\alpha - 1)^2 + (\beta - 2)^2 = (\alpha - 5)^2 + (\beta - 6)^2$$

$$= (\alpha - 9)^2 + (\beta - 13)^2$$

$$\Rightarrow \alpha + \beta = 7$$

$$12(\alpha + \beta) = 84$$

14.

15.

16.

17.

18.

19.

20.

Our Problem Solvers shine bright in **JEE 2025**

JEE (Advanced)

ADVAY
MAYANK
AIR 36



RUJUL
GARG
AIR 41



ARUSH
ANAND
AIR 64



JEE (MAIN)

SHREYAS
LOHIYA
AIR 6
Uttar Pradesh Topper
100 Overall



KUSHAGRA
BAINGAHA
AIR 7
Uttar Pradesh Topper
100 Overall



HARSH
A GUPTA
AIR 15
Telangana Topper
100 Overall



SECTION - B

Numerical Value Type Questions: This section contains 5 Numerical based questions. The answer to each question should be rounded-off to the nearest integer.

21. Let $A = \{1, 2, 3, 4, 5\}$ and $B = \{a, b, c\}$. Then the number of functions which are not onto are

Answer (93)

Sol. Total number of into function = total function – (Number of onto function)

$$= 3^5 - (3^5 - {}^3C_1(3-1)^5 + {}^3C_2(3-2)^5)$$

$$= 3 \times 32 - 3 \times 1$$

$$= 96 - 3$$

$$= 93$$

22. If fair coin is tossed 8 times. If the probability that first 6 throws contains 4 heads and last 5 throws contains exactly 3 heads is P then $96P$ is equal to

Answer (09.00)

Sol. If score = 1 if head and 0 if tail then

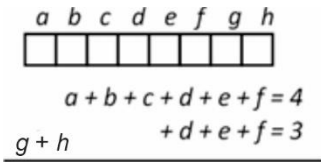

A. If $d + e + f = 3$ then $a + b + c = 1$ and $g + h = 0$

B. If $d + e + f = 2$ then $a + b + c = 2$ and $g + h = 1$

C. If $d + e + f = 1$ then $a + b + c = 3$ and $g + h = 2$

A. ${}^3C_3 \times \left(\frac{1}{2}\right)^3 \times {}^3C_1 \left(\frac{1}{2}\right)^1 \left(\frac{1}{2}\right)^2 \times {}^2C_0 \left(\frac{1}{2}\right)^0 \left(\frac{1}{2}\right)^2$
 $= \left(\frac{1}{2}\right)^8 [{}^3C_3 \times {}^3C_1 \times {}^2C_0] = 3 \times \frac{1}{2^8}$

B. $\left(\frac{1}{2}\right)^8 ({}^3C_2 \times {}^3C_2 \times {}^2C_1) = 18 \times \frac{1}{2^8}$

C. $\left(\frac{1}{2}\right)^8 ({}^3C_1 \times {}^3C_3 \times {}^2C_2) = 3 \times \frac{1}{2^8}$

$$\Rightarrow \text{total probability} = \frac{24}{2^8} = \frac{3}{2^5} = \frac{3}{32}$$

$$\Rightarrow \frac{96 \times 3}{32} = 9$$

23. Consider 8 observations $a, b, 8, 103, 13, 21, 67, 17$ where $a > b$. If Median and Mean deviation about Median are 21 and 26 respectively. Then, the value of $2a$ is

Answer (152)

Sol. 8, 13, 17, 21, 67, 103, b, a

Since, Median = 21

\Rightarrow 21 should be on 4th or 5th place

and since $b < a$

$$b = 21$$

Now Mean deviation about Median = 26

$$\Rightarrow \frac{|8-21| + |13-21| + |17-21| + |67-21| + |a-21|}{8} = 26$$

$$\Rightarrow |a-21| + 153 = 208$$

$$\Rightarrow |a-21| = 55$$

$$\Rightarrow a = 76$$

Note : In the case of $a + b = 42$ and lie b/w 17 top 21, that is not possible hence $b < a$ is sufficient condition to uniquely determine a and b .

24.

25.



Our Problem *Solvers* shine bright in **JEE 2025**

JEE (Advanced)

ADVAY
MAYANK
AIR 36



RUJUL
GARG
AIR 41



ARUSH
ANAND
AIR 64



JEE (MAIN)

SHREYAS
LOHIYA
AIR 6
Uttar Pradesh Topper
100 Overall



KUSHAGRA
BAINGAHA
AIR 7
Uttar Pradesh Topper
100 Overall



HARSSH
A GUPTA
AIR 15
Telangana Topper
100 Overall

