

05/04/2026

Morning



Aakash

Medical | IIT-JEE | Foundations

Corporate Office : AESL, 3rd Floor, Incuspaze Campus-2, Plot-13, Sector-18, Udyog Vihar,
Gurugram, Haryana-122015

Memory Based Answers & Solutions

Time : 3 hrs.

for

M.M. : 300

JEE (Main)-2026 (Online) Phase-2

(Physics, Chemistry and Mathematics)

Don't guess your JEE Main score.

Calculate it Instantly

with our

JEE Main Score Calculator.

HOW TO GET YOUR SCORES

- Open your response sheet on the JEE Main Site
- Copy the link from the browser's Address bar
- Paste it into the required field in the Calculator



Scan the QR code
to know more.



jee-marks-calculator.aakash.ac.in/

Our Problem *Solvers* shine bright in **JEE 2025**

JEE (Advanced)

ADVAY
MAYANK
AIR 36



RUJUL
GARG
AIR 41



ARUSH
ANAND
AIR 64



SHREYAS
LOHIYA
AIR 6
Uttar Pradesh Topper
100 Overall



KUSHAGRA
BAINGAHA
AIR 7
Uttar Pradesh Topper
100 Overall



HARSSH
A GUPTA
AIR 15
Telangana Topper
100 Overall



PHYSICS

SECTION - A

Multiple Choice Questions: This section contains 20 multiple choice questions. Each question has 4 choices (1), (2), (3) and (4), out of which **ONLY ONE** is correct.

Choose the correct answer:

1. As shown in figure, the ratio of T_1 and T_2 is

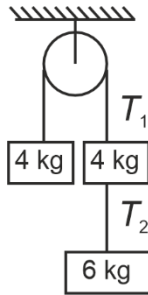

- (1) 5/3
- (2) 4/3
- (3) 10/3
- (4) 6/3

Answer (1)

Sol. $a = \frac{(10g - 4g)}{14} = \frac{6g}{14} = \frac{3g}{7}$

$6g - T_2 = 6 \times \frac{3g}{7}$

$\Rightarrow T_2 = 6g - 3 \times \frac{6g}{7} = 6g \times \frac{4}{7}$

And $T_1 - 4g = 4 \times \frac{3g}{7}$

$T_1 = 4g \left(1 + \frac{3}{7}\right) = 4g \times \frac{10}{7}$

$\frac{T_1}{T_2} = \frac{5}{3}$

2. For the circuit shown below, find current across AB (I_{AB})

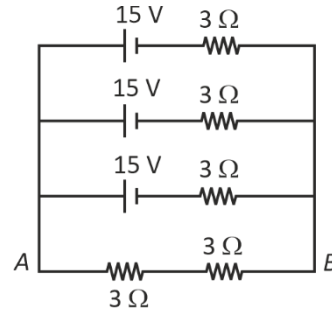

- (1) $\frac{10}{7}$ A
- (2) $\frac{13}{7}$ A
- (3) $\frac{11}{7}$ A
- (4) $\frac{15}{7}$ A

Answer (4)

Sol. $\frac{1}{r_0} = \frac{1}{3} + \frac{1}{3} + \frac{1}{3} = 1$

$\Rightarrow r_0 = 1 \Omega$

$\epsilon_0 = \frac{\epsilon(r^2) \times 3}{3r^2} = \epsilon = 15 \text{ V}$

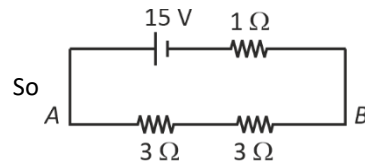

So $I_{AB} = \frac{15}{7}$

Our Problem Solvers shine bright in **JEE 2025**

JEE (Advanced)

ADVAY
MAYANK
AIR 36



RUJUL
GARG
AIR 41



ARUSH
ANAND
AIR 64



SHREYAS
LOHIYA
AIR 6
Uttar Pradesh Topper
100 Rank in Overall



KUSHAGRA
BAINGAHA
AIR 7
Uttar Pradesh Topper
100 Rank in Overall



HARSSH
A GUPTA
AIR 15
Telangana Topper
100 Rank in Overall



3. Speed of light in the prism = 2×10^8 m/s. Then find minimum deviation through the prism.

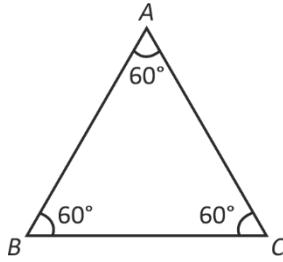

- (1) $2\sin^{-1}\left(\frac{3}{4}\right) - 30^\circ$ (2) $2\sin^{-1}\left(\frac{3}{4}\right) + 30^\circ$
 (3) $2\sin^{-1}\left(\frac{3}{4}\right) + 60^\circ$ (4) $2\sin^{-1}\left(\frac{3}{4}\right) - 60^\circ$

Answer (4)

Sol. $\mu = \frac{\sin\left(\frac{\delta_m + A}{2}\right)}{\sin\left(\frac{A}{2}\right)}$

$A = 60^\circ, u = \frac{3 \times 10^8}{2 \times 10^8} = \frac{3}{2}$

$\frac{3}{2} = \frac{\sin\left(\frac{\delta_m + 60^\circ}{2}\right)}{\sin\left(\frac{60^\circ}{2}\right)}$

$\delta = 2\sin^{-1}\left(\frac{3}{4}\right) - 60^\circ$

4. Select the quantity with matching dimensions of $ML^2 T^{-4} A^{-2}$.

- (1) $\frac{R}{\sqrt{LC}}$ (2) $\frac{1}{R} \sqrt{\frac{L}{C}}$
 (3) $\frac{R}{LC}$ (4) $\frac{C}{\sqrt{LR}}$

Answer (1)

Sol. $R = \frac{V}{i} = \frac{ML^2 T^{-2}}{A^2 T} = ML^2 T^{-3} A^{-2}, \sqrt{LC} = T$

$R_{req. \text{ dimension}} = \frac{R}{\text{time}} \Rightarrow \text{option-1}$

5. Two points A and B are 16 km from surface of earth.

Acceleration due to gravity at A & B is g_A & g_B , then $\frac{g_A}{g_B} =$

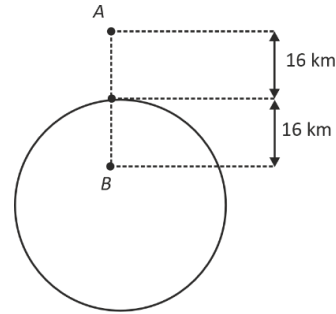

- (1) $\frac{1}{2}$ (2) $\frac{149}{200}$
 (3) $\frac{398}{399}$ (4) $\frac{441}{442}$

Answer (3)

Sol. Ratio = $\frac{g_0 \left(1 - \frac{2 \times 16}{6400}\right)}{g_0 \left(1 - \frac{16}{6400}\right)} = \frac{6400 - 32}{6400 - 16} = \frac{400 - 2}{400 - 1} = \frac{398}{399}$

6. Young's modulus of wire is Y. Keeping material same, if radius of wire is doubled while length is halved. Then new value of Young's modulus is

- (1) 2Y (2) 4Y
 (3) Y (4) $\frac{Y}{2}$

Answer (3)

Sol. Young's modulus depends on material.

7. In circuit given below, $L_1 = L_2 = L_3$ & total energy stored in system is E_1 & energy stored in L_2 is E_2 . Then find $\frac{E_1}{E_2}$

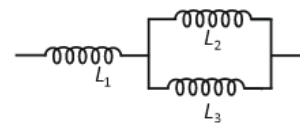

- (1) 6 (2) 4
 (3) 1 (4) 3

Answer (1)

Our Problem Solvers shine bright in **JEE 2025**

JEE (Advanced)

JEE (MAIN)

ADVAY MAYANK AIR 36 RUJUL GARG AIR 41 ARUSH ANAND AIR 64

SHREYAS LOHIYA AIR 6 Uttar Pradesh Topper 100 KUSHAGRA BAINGAHA AIR 7 Uttar Pradesh Topper 100 HARSH A GUPTA AIR 15 Telangana Topper 100

Sol. Energy in L_3 will also be E_2

& in L_1 it will be $4E_2$

$$\therefore 2E_2 + 4E_2 = E_1$$

$$\Rightarrow 6E_2 = E_1$$

$$\therefore \frac{E_1}{E_2} = 6$$

8. Breaking stress of both wires is $1.2 \times 10^8 \text{ N/m}^2$ area of cross section of both wire is 0.008 cm^2 .

Find maximum value of m such that no wire breaks. ($g = 10 \text{ m/s}^2$)

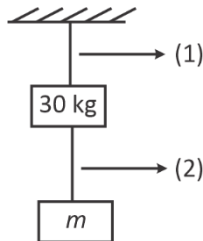

(1) 4.1 kg

(2) 6.6 kg

(3) 8.7 kg

(4) 9 kg

Answer (2)

Sol. Wire 1 would tend to break first

$$\therefore \frac{30 + mg}{A} = 1.2 \times 10^8$$

$$\Rightarrow 30 + 10m = 1.2 \times 10^8 \times 0.008 \times 10^{-4}$$

$$\Rightarrow 10m = 1.2 \times 10 \times 8 - 30$$

$$m = 6.6 \text{ kg}$$

9. In a region where electric field exist as $-E_0 \hat{i}$ (V/m). Initial (at $t = 0$) velocity of particle of mass m is $4V_0 \hat{i}$.

$$\lambda_0 = \frac{h}{4mv_0} \text{ at instant } t = 0, \text{ then find } \lambda \text{ in terms of } \lambda_0 \text{ at}$$

time instant t .

$$(1) \lambda = \frac{h\lambda_0}{h + qE_0\lambda_0 t}$$

$$(2) \lambda = \frac{h\lambda_0}{h - qE_0\lambda_0 t}$$

$$(3) \lambda = \frac{h\lambda_0}{(h + 2E_0q\lambda_0 t)}$$

$$(4) \lambda = \frac{h\lambda_0}{\left(h + \frac{qE_0\lambda_0 t}{2}\right)}$$

Answer (2)

$$\text{Sol. } \lambda = \frac{h}{p}$$

at $t = 0$

$$P = 4mV_0.$$

$$\text{So } \lambda_0 = \frac{h}{4mV_0}$$

At t

$$V = 4V_0 - \left(\frac{qE_0}{m}\right)t$$

$$P = 4mV_0 - \frac{qE_0}{t}$$

$$\lambda = \frac{h}{4mV_0 - qE_0 t} = \frac{h}{\left(\frac{h}{\lambda_0} - qE_0 t\right)}$$

$$\Rightarrow \lambda = \frac{h\lambda_0}{h - qE_0\lambda_0 t}$$

10. In thermodynamics, with usual symbols two expressions are given

$$\text{Expression 1: } \Delta U = \mu C_v \Delta T + \frac{\mu R \Delta T}{\gamma - 1}$$

$$\text{Expression 2: } \gamma f = f + 2$$

Then

(1) E1 is correct and E2 is incorrect

(2) E1 is incorrect and E2 is correct

(3) E1, E2 are correct

(4) E1, E2 are incorrect

Answer (2)

Sol. Theoretical.

Our Problem Solvers shine bright in **JEE 2025**

JEE (Advanced)

ADVAY
MAYANK
AIR 36



RUJUL
GARG
AIR 41



ARUSH
ANAND
AIR 64



SHREYAS
LOHIYA
AIR 6
Uttar Pradesh Topper
100



KUSHAGRA
BAINGAHA
AIR 7
Uttar Pradesh Topper
100



HARSH
A GUPTA
AIR 15
Telangana Topper
100



11. Moment of inertia of rod about an axis passing through point at distance $\frac{l}{4}$ from center and perpendicular to rod is (The uniform rod is of mass m and length l)

- (1) $\frac{8}{63} ml^2$
- (2) $\frac{3}{7} ml^2$
- (3) $\frac{7}{44} ml^2$
- (4) $\frac{7}{48} ml^2$

Answer (4)

Sol. $I = \frac{ml^2}{12} + m\left(\frac{l}{4}\right)^2 = \left(\frac{1}{12} + \frac{1}{16}\right)ml^2 = \frac{7}{48} ml^2$

12. For a wave, equation is given as $y = 3 \sin(\omega t - 0.018x + \pi/4)$. Find the minimum distance between consecutive crest.

- (1) $\frac{200}{3} \pi$ (m)
- (2) $\frac{400}{3} \pi$ (m)
- (3) $\frac{1000}{9} \pi$ (m)
- (4) $\frac{500}{9} \pi$ (m)

Answer (3)

Sol. Distance between two consecutive crest is λ .

So, $\lambda = \frac{2\pi}{k} = \frac{2\pi}{0.018}$
 $\Rightarrow \lambda = \frac{1000\pi}{9} \text{ m.}$

13. Both LED's will switch on in which of the following option:

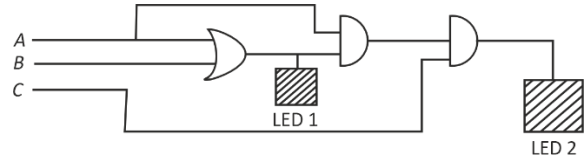

- (1)

| | | |
|---|---|---|
| A | B | C |
| 1 | 1 | 0 |
- (2)

| | | |
|---|---|---|
| A | B | C |
| 1 | 0 | 0 |
- (3)

| | | |
|---|---|---|
| A | B | C |
| 1 | 0 | 1 |
- (4)

| | | |
|---|---|---|
| A | B | C |
| 0 | 1 | 1 |

Answer (3)

Sol. For $A = 1$ $B = 0$ and $C = 1$

Both LEDs will switch on

14. A ball is dropped from 18 m high tower. Find distance of ball from ground when the speed of ball becomes equal to magnitude of acceleration of ball ($g = 10 \text{ m/s}^2$)

- (1) 8
- (2) 18
- (3) 13
- (4) 10

Answer (3)

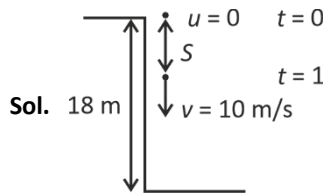

Sol. 18 m
 $S = \frac{1}{2} \times 10 \times 1^2 = 5$

\therefore Distance from ground will be 13 m.

Our Problem Solvers shine bright in **JEE 2025**

JEE (Advanced)

JEE (MAIN)

| | | |
|-------------------------------|-----------------------------|------------------------------|
| ADVAY MAYANK AIR 36 | RUJUL GARG AIR 41 | ARUSH ANAND AIR 64 |
|-------------------------------|-----------------------------|------------------------------|

| | | |
|---|--|--|
| SHREYAS LOHIYA AIR 6 Uttar Pradesh Topper 100 | KUSHAGRA BAINGAHA AIR 7 Uttar Pradesh Topper 100 | HARSSH A GUPTA AIR 15 Telangana Topper 100 |
|---|--|--|

15. On the top surface of a cube (length = 5 cm) force F is acting tangentially. Lower surface is fixed, then find shifting x .

[Modulus of rigidity $\eta = 10^5$ (SI unit)]

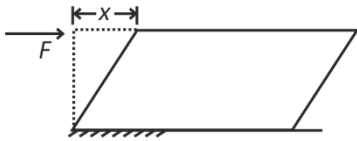

(1) $x = \frac{F}{2500}$

(2) $x = \frac{F}{5000}$

(3) $x = \frac{F}{4000}$

(4) $x = \frac{F}{8000}$

Answer (2)

Sol. $\frac{F \cdot h}{A \cdot x} = \eta$

$$\Rightarrow x = \frac{F \times 5 \times 10^{-2}}{25 \times 10^{-4} \times 10^5}$$

$$\Rightarrow x = \frac{F}{5000}$$

16. 10 VSD matches with 9 MSD in a vernier calliper. 1 MSD is of 1 mm. When no reading is taken, the zero of vernier scale is just right of zero of main scale and 7th VSD matches with one MSD then zero error is

- (1) 0.7 cm, +ve (2) 0.7 cm, -ve
(3) 0.7 mm, -ve (4) 0.7 mm, +ve

Answer (4)

Sol. $LC = 0.1 \text{ mm}$

Error = 0.7 mm

17. In circuit given below, current in circuit is i_0 . If angular frequency is changed from ω_0 to $\frac{\omega_0}{8}$ the current becomes

$\frac{i_0}{4}$. Find $\frac{1}{\omega_0 CR}$

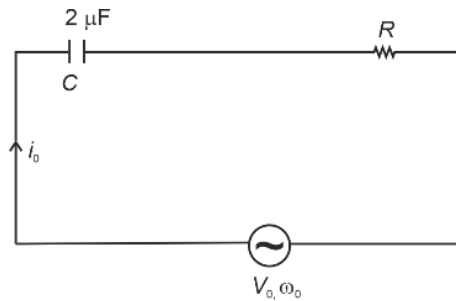

(1) $\sqrt{\frac{5}{16}}$

(2) $\sqrt{\frac{42}{13}}$

(3) $\sqrt{\frac{51}{38}}$

(4) $\sqrt{\frac{3}{2}}$

Answer (1)

Sol. $i_0 = \frac{V_0}{\sqrt{R^2 + X_L^2}}$

And $\frac{i_0}{4} = \frac{V_0}{\sqrt{R^2 + X_C^2 64}}$

$$\Rightarrow 4 = \frac{\sqrt{R^2 + X_L^2 64}}{\sqrt{R^2 + X_C^2}}$$

18. In hydrogen atom an electron is revolving in 4th Bohr's orbit. Find wavelength of the incident radiation to excite this electron to 16th Bohr's orbit. [Use $hc = 1240 \text{ nm.ev}$.]

- (1) 1556 nm. (2) 400 nm.
(3) 800 nm. (4) 2000 nm.

Answer (1)

Our Problem Solvers shine bright in **JEE 2025**

JEE (Advanced)

ADVAY
MAYANK
AIR 36



RUJUL
GARG
AIR 41



ARUSH
ANAND
AIR 64



SHREYAS
LOHIYA
AIR 6
Uttar Pradesh Topper
100



KUSHAGRA
BAINGAHA
AIR 7
Uttar Pradesh Topper
100



HARSSH
A GUPTA
AIR 15
Telangana Topper
100



Sol. $\Delta E = E_0 \left[\frac{1}{16} - \frac{1}{256} \right] = \frac{hc}{\lambda}$
 $\Rightarrow E_0 \left(\frac{15}{256} \right) = \frac{hc}{\lambda}$
 $\Rightarrow \lambda = \frac{1240 \times 256}{13.6 \times 15} = 1556 \text{ nm}$

19.
20.

SECTION - B

Numerical Value Type Questions: This section contains 5 Numerical based questions. The answer to each question should be rounded-off to the nearest integer.

21. In a YDSE setup in air, fringe width is 2.4 μm . If we submerge the setup in a liquid of refractive index 1.2 then find the new fringe width (in μm).

Answer (2)

Sol. $\Delta w = \frac{\lambda D}{d}$

But in case of medium with $m = 1.2$

$\Delta w' = \frac{\lambda D}{1.2 d}$

So $\frac{\Delta w'}{\Delta w} = \frac{\lambda D d}{1.2 d \times \lambda D} = \frac{1}{1.2}$

$\Rightarrow \Delta w' = \left(\frac{2.4}{1.2} \right) \mu\text{m} = 2 \mu\text{m}$

22. A particle moving uniformly enters a region having uniform magnetic field $(3\hat{i} + 2\hat{j})T$. Its acceleration is $\left(4\hat{i} - \frac{x}{2}\hat{j} \right) \text{ m/s}^2$. Find the value of x.

Answer (12)

- Sol. As the acceleration and magnetic field are in x-y plane so velocity must be in z direction

So $\frac{q(v\hat{k}) \times (3\hat{i} + 2\hat{j})}{m} = \left(4\hat{i} - \frac{x}{2}\hat{j} \right)$

$\Rightarrow \frac{qv}{m} (3\hat{j} - 2\hat{i}) = 4\hat{i} - \frac{x}{2}\hat{j}$

Clearly $\frac{qv}{m} = -2$

So acceleration will be

$(4\hat{i} - 6\hat{j}) = \left(4\hat{i} - \frac{x}{2}\hat{j} \right)$

Clearly $x = 12$

23. Two microscopes gives same magnification in which objective lens are same and eyepiece of 2 is exactly half of eyepiece 1 which is equiconvex. Then $\frac{L_2}{L_1}$ is

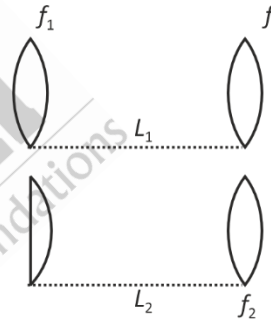

Answer (2)

Sol. $M = \frac{DL}{f_0 f_e} \Rightarrow \frac{L_1}{f_1} = \frac{L_2}{f_1'}; \frac{1}{f} = (\mu - 1) \left(\frac{1}{R_1} + \frac{1}{R_2} \right)$

$\frac{1}{f_1} = \frac{2(\mu - 1)}{R}$

$\frac{L_2}{L_1} = 2; \frac{1}{f_1} = \frac{2(\mu - 1)}{R} \Rightarrow 2f_1 = f_1'$

24.
25.

Our Problem Solvers shine bright in **JEE 2025**

JEE (Advanced)

| | | | | | |
|-------------------------------|--|-----------------------------|--|------------------------------|--|
| ADVAY MAYANK AIR 36 | | RUJUL GARG AIR 41 | | ARUSH ANAND AIR 64 | |
|-------------------------------|--|-----------------------------|--|------------------------------|--|

JEE (MAIN)

| | | | | | |
|---|--|--|--|--|--|
| SHREYAS LOHIYA AIR 6 Uttar Pradesh Topper 100 | | KUSHAGRA BAINGAHA AIR 7 Uttar Pradesh Topper 100 | | HARSSH A GUPTA AIR 15 Telangana Topper 100 | |
|---|--|--|--|--|--|

CHEMISTRY

SECTION - A

Multiple Choice Questions: This section contains 20 multiple choice questions. Each question has 4 choices (1), (2), (3) and (4), out of which **ONLY ONE** is correct.

Choose the correct answer :

1. Compare the energy of orbitals for multielectronic species.

| | | | |
|-------------------|-------------------|----|--|
| n | l | m | |
| (A) 3 | 0 | 0 | |
| (B) 3 | 1 | -1 | |
| (C) 4 | 2 | 0 | |
| (D) 3 | 2 | 1 | |
| (1) C > D > B > A | (2) C > B > D > A | | |
| (3) A > B > C > D | (4) A > B > D > C | | |

Answer (1)

Sol. (A) 3s (B) 3p (C) 4d (D) 3d

More the value of (n + l) more will be the energy of orbital.

2. Which of the following will produce C₆H₅NC?

- (1) C6H5NO2 $\xrightarrow{\text{CHCl}_3/\text{KOH}}$
- (2) C6H5NH2 $\xrightarrow{\text{CHCl}_3/\text{KOH(alc)}}$
- (3) C6H5CH2NH2 $\xrightarrow{\text{AgCN}}$
- (4) C6H5CH2Cl $\xrightarrow{\text{KCN}}$

Answer (2)

Sol. C6H5NH2 $\xrightarrow{\text{CHCl}_3/\text{KOH}}$ C6H5NC

Carbylamine reaction

3. Consider the sequence :

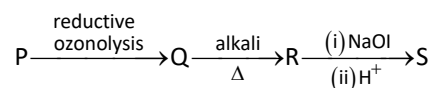

If 'S' is , then 'P' is

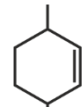
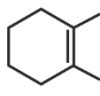
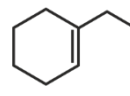
- (1) 
- (2) 
- (3) 
- (4) 

Answer (3)

Sol.

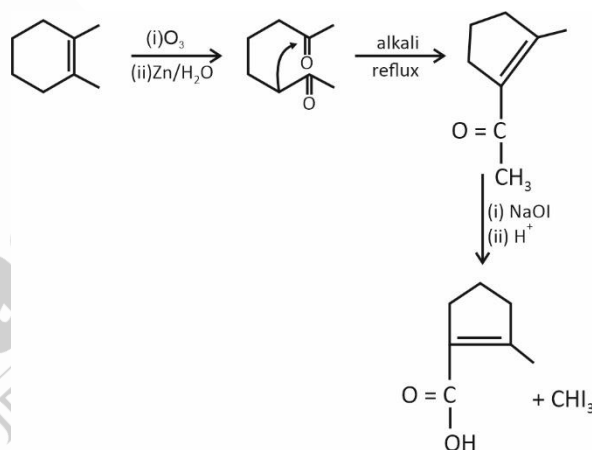

4. Given below are two statements:

Statement I: K₂Cr₂O₇ can be used as a primary standard

Statement II: Phenolphthalein is a weak base indicator

In the light of above statements choose the correct option.

- (1) Both statement I and statement II are correct
- (2) Statement I is correct but statement II is incorrect
- (3) Statement I is incorrect but statement II is correct
- (4) Both statement I and statement II are incorrect

Answer (2)

Our Problem *Solvers* shine bright in **JEE 2025**

JEE (Advanced)

ADVAY
MAYANK
AIR 36



RUJUL
GARG
AIR 41



ARUSH
ANAND
AIR 64



JEE (MAIN)

SHREYAS
LOHIYA
AIR 6
Uttar Pradesh Topper
100 Overall



KUSHAGRA
BAINGAHA
AIR 7
Uttar Pradesh Topper
100 Overall



HARSSH
A GUPTA
AIR 15
Telangana Topper
100 Overall



Sol. $K_2Cr_2O_7$ is available in high purity, is non hygroscopic, is stable at room temperature and has a molar mass, which minimizes weighing errors

Statement-I is correct

Phenolphthalein is actually a weak organic acid.

Statement II is incorrect

5. What amount of residue will be produced on heating 2.76 gram of pure Ag_2CO_3 ?

- (1) 1.08 g (2) 2.16 g
(3) 3.2 g (4) 4.32 g

Answer (2)

Sol.

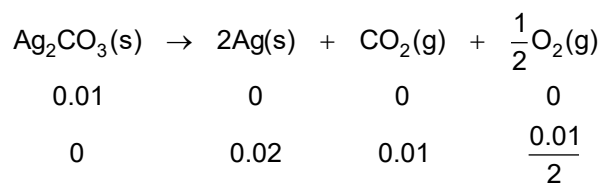

Mass of residue = mass of Ag = $0.02 \times 108 = 2.16$ g

6. Consider the following reaction

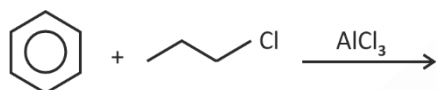

Choose the incorrect statement

- (1) Isopropylation intermediate is formed in the reaction
(2) Isopropyl benzene is the major product formed
(3) Rearrangement of carbocation occurs
(4) The product is less reactive than benzene towards electrophilic aromatic substitution.

Answer (4)

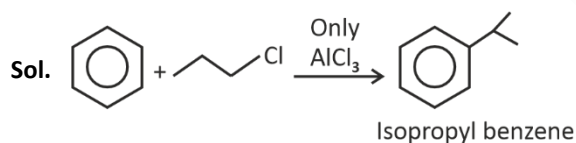

7. pH of 10^{-7} M aq. KOH solution at 25° is,

- (1) 6.50 (2) 6.70
(3) 7.3 (4) 7.00

Answer (3)

Sol. $H_2O \rightleftharpoons H^+ + OH^-$

$$x \quad x + 10^{-7}$$

$$x(x + 10^{-7}) = 10^{-14}$$

Upon solving

$$\text{Total } OH^- \cong 1.98 \times 10^{-7}$$

$$pOH = 6.7$$

$$pH = 7.3$$

8. Given below are two statements:

Statement I: Stability of carbanion is as follows

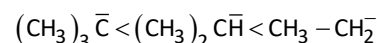

Statement II: Stability of above carbanion can be explained on the basis of inductive effect

- (1) Both statement I and II are correct
(2) Both statement I and II are incorrect
(3) Statement I is correct and statement II is incorrect
(4) statement I is incorrect and statement II is correct

Answer (1)

Sol. More is +I effect lesser is the stability of carbanion $3^\circ < 2^\circ < 1^\circ$

9. Given below two statements :

Statement I : In octahedral complexes each electrons in t_{2g} orbital stabilises by $-0.4\Delta_o$ and that of e_g orbital destabilises by $+0.6\Delta_o$.

Statement II : All d-electrons are of same energy in free state but after complex is formed its degeneracy is disturbed according to crystal field theory.

- (1) Both Statement I and Statement II are correct
(2) Both Statement I and Statement II are incorrect
(3) Statement I is correct, Statement II is incorrect
(4) Statement I is incorrect, Statement II is correct

Answer (1)

Our Problem Solvers shine bright in **JEE 2025**

JEE (Advanced)

ADVAY
MAYANK
AIR 36



RUJUL
GARG
AIR 41



ARUSH
ANAND
AIR 64



JEE (MAIN)

SHREYAS
LOHIYA
AIR 6
Uttar Pradesh Topper
100 Overall



KUSHAGRA
BAINGAHA
AIR 7
Uttar Pradesh Topper
100 Overall



HARSSH
A GUPTA
AIR 15
Telangana Topper
100 Overall



Sol. According to CFT, the d-orbitals splits into t_{2g} set and e_g set of orbitals.

The t_{2g} set decreases in energy by $0.4\Delta_o$ and the e_g set increases in energy by $0.6\Delta_o$

Statement I is correct.

Before complex formation all d-orbitals are degenerate.

Statement II is correct.

10. Consider the following statements

- Glucose exists in two anomeric forms
- Melting point of α -anomer is greater than β -anomer
- Specific rotation of α -anomer is 19° and for β -anomer is 112°
- α and β anomers are formed at temperature 303 K and 371 K

Choose the correct statements:

- a, b, c only
- a, d only
- a, c, d only
- a, b, c, d

Answer (2)

- Sol.**
- Glucose is found to exist in 2 different crystalline forms which are named as α and β
 - The α -form of glucose (m.p \rightarrow 419K) is obtained by crystallization from conc. solution by glucose at 303 K while the β -form (m.p \rightarrow 423 K) is obtained by crystallization from hot and saturated aqueous solution at 371 K.

$\therefore \alpha \Rightarrow 112^\circ$ (specific rotation)

$\beta \Rightarrow 19^\circ$ (specific rotation)

11. **Statement I** : Order of electronegativity is $F > O > N$.

Statement II : In OF_2 , oxidation state of 'O' is +2 and in N_2O , the value of oxidation state of O is -2.

- Both statement I and statement II are wrong
- Statement II is wrong, statement I is correct
- Both statement I and statement II are correct
- Statement I is correct, statement II is wrong

Answer (3)

Sol. en

| | |
|---|-----|
| F | 4 |
| O | 3.5 |
| N | 3.0 |

12. Consider the following statements

Statement-I: $\Delta U = n(C_{v,m}) \Delta T = \frac{nR}{\gamma-1} [T_2 - T_1]$

where $\gamma = \frac{C_p}{C_v}$

Statement-II: If degree of freedom = f, then $\gamma = 1 + \frac{2}{f}$

- Both statement I and II are correct
- Both statement I and II are incorrect
- Statement I is correct and statement II is incorrect
- Statement I is incorrect and statement II is correct

Answer (1)

Sol. $\Delta U = nC_v \Delta T$

$$C_p - C_v = R$$

$$\frac{C_p}{C_v} = \gamma$$

$$\gamma - 1 = \frac{R}{C_v}$$

$$C_v = \frac{R}{\gamma - 1}$$

$$\Delta U = \frac{nR}{\gamma - 1} (T_2 - T_1)$$

Statement I is correct

$$C_v = \frac{f}{2} R$$

$$C_p = C_v + R$$

$$C_p = \frac{f}{2} R + R$$

Our Problem Solvers shine bright in **JEE 2025**

JEE (Advanced)

ADVAY
MAYANK
AIR 36



RUJUL
GARG
AIR 41



ARUSH
ANAND
AIR 64



JEE (MAIN)

SHREYAS
LOHIYA
AIR 6
Uttar Pradesh Topper
100 Overall



KUSHAGRA
BAINGAHA
AIR 7
Uttar Pradesh Topper
100 Overall



HARSSH
A GUPTA
AIR 15
Telangana Topper
100 Overall



$$C_p = \left(\frac{f}{2} + 1\right)R$$

$$\gamma = \frac{C_p}{C_v} = \frac{\left(\frac{f}{2} + 1\right)R}{\frac{f}{2}R} = \left(1 + \frac{2}{f}\right)$$

Statement II is true

13. Arrange the following mixtures in increasing order of pH at 25°C (each solution is decimolar).

- (a) 10 mL of HCl + 10 mL of Ca(OH)₂
 (b) 10 mL of HCl + 25 mL of Ca(OH)₂
 (c) 10 mL of HCl + 10 mL of H₂SO₄

- (1) b < a < c
 (2) a < b < c
 (3) c < a < b
 (4) b < c < a

Answer (3)

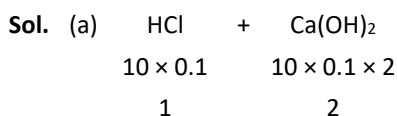

m moles of OH⁻ = 1 [OH⁻] = $\frac{1}{20}$ M

pOH = 1.3

pH = 12.7

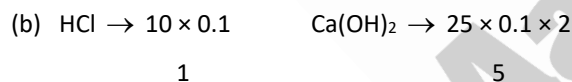

m moles of OH⁻ = 4 [OH⁻] = $\frac{4}{35}$ M = 0.1142

pOH = 0.94

pH = 13.06



m moles of H⁺ = $\frac{3}{20}$ M

pH = 0.82

14. Consider the following statements :

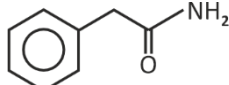
Statement I :  $\xrightarrow{\text{NaOBr}}$ primary aromatic amine.

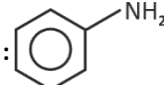
Statement II :  can be prepared by Gabriel phthalimide synthesis.

Choose the correct option

- (1) Both statement I and statement II are correct
 (2) Statement I is correct but statement II is incorrect
 (3) Statement I is incorrect but statement II is correct
 (4) Both statement I and statement II are incorrect

Answer (4)

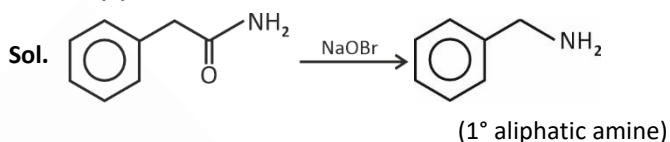

PhNH₂ can't be prepared from Gabriel Phthalimide synthesis.

15. Consider the following sequence of reactions.

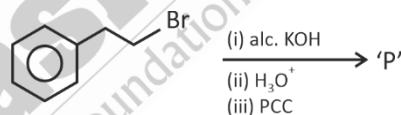

The final major product (P) is

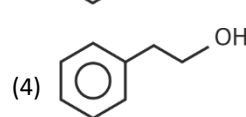
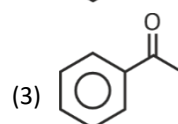
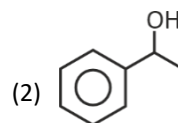
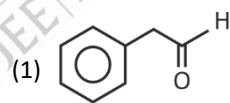

Answer (3)

Our Problem Solvers shine bright in **JEE 2025**

JEE (Advanced)

ADVAY
MAYANK
AIR 36



RUJUL
GARG
AIR 41



ARUSH
ANAND
AIR 64



JEE (MAIN)

SHREYAS
LOHIYA
AIR 6
Uttar Pradesh Topper
100 Overall



KUSHAGRA
BAINGAHA
AIR 7
Uttar Pradesh Topper
100 Overall



HARSSH
A GUPTA
AIR 15
Telangana Topper
100 Overall



Sol.

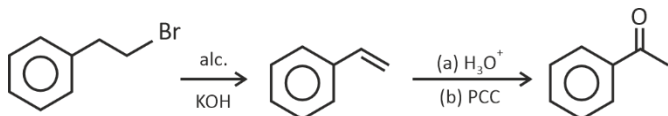

16. The correct relationship between the molar concentration of the anion $[A^{3-}]$ and the solubility product constant (K_{sp}) for an M_3A_2 type salt

(1) $[A^{3-}] = \left(\frac{K_{sp}}{108}\right)^{\frac{1}{5}}$

(2) $[A^{3-}] = \left(\frac{8 K_{sp}}{27}\right)^{\frac{1}{5}}$

(3) $[A^{3-}] = \left(\frac{27 K_{sp}}{8}\right)^{\frac{1}{5}}$

(4) $[A^{3-}] = \left(\frac{4 K_{sp}}{9}\right)^{\frac{1}{5}}$

Answer (2)

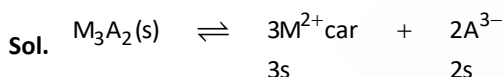

$[A^{3-}] = 2s$

$s = \frac{[A^{3-}]}{2}$

$K_{sp} = (3s)^3 (2s)^2$

$K_{sp} = 27 s^3 \times 4 s^2$

$= 108 s^5$

$K_{sp} = 108 \left(\frac{[A^{3-}]}{2}\right)^5$

$K_{sp} = \frac{108}{32} [A^{3-}]^5$

$K_{sp} = \frac{27}{8} [A^{3-}]^5$

$[A^{3-}]^5 = \frac{8 K_{sp}}{27}$

$[A^{3-}] = \left(\frac{8 K_{sp}}{27}\right)^{\frac{1}{5}}$

17. The order of acidic strength for 0.1 M aqueous solution of following is

A. CH_3COOH

B. H_3PO_3

C. H_3PO_4

(1) $B > C > A$

(2) $A > C > B$

(3) $A > B > C$

(4) $C > B > A$

Answer (1)

Sol. $K_a CH_3COOH = 1.76 \times 10^{-5}$

$K_a H_3PO_3 = 1.6 \times 10^{-2}$

$K_a H_3PO_4 = 7.5 \times 10^{-3}$

$[H^+] = \sqrt{K_a \cdot C}$, $[H^+] \propto \sqrt{K_a}$

18.

19.

20.

Our Problem Solvers shine bright in **JEE 2025**

JEE (Advanced)

ADVAY
MAYANK
AIR 36



RUJUL
GARG
AIR 41



ARUSH
ANAND
AIR 64



SHREYAS
LOHIYA
AIR 6
Uttar Pradesh Topper
100 Overall



KUSHAGRA
BAINGAHA
AIR 7
Uttar Pradesh Topper
100 Overall



HARSSH
A GUPTA
AIR 15
Telangana Topper
100 Overall



SECTION - B

Numerical Value Type Questions: This section contains 5 Numerical based questions. The answer to each question should be rounded-off to the nearest integer.

21. 0.2 g of organic compound is subjected to estimation of 'S' by Carius method, giving 0.6 g BaSO₄. Find % of S. (Nearest integer).

Answer (41)

Sol. Mass of S = $\frac{0.6}{233} \times 32 = 0.082$ g

% of S = $\frac{0.082}{0.2} \times 100 = 41.20\%$

22. Half life for a first order reaction is 6.93 min. What is the time required (in min) to complete 90% of reaction? (Nearest integer)

Answer (23)

Sol. $t_{1/2} = 6.93$ min

$k = \frac{0.693}{6.93} = 0.1 \text{ min}^{-1}$

$t_{90\%} = \frac{2.303}{0.1} \log \frac{100}{10}$

= 23.03 min

23. How many compounds among the following having sp^3d hybridisation of central atom BrF₅, XeF₅⁻, ICl₂⁻, ICl₄⁻, SF₄, NH₄⁺, ClF₃, XeF₂, XeF₄

Answer (4)

Sol. BrF₅ ⇒ Steric no. = 6 sp^3d^2

XeF₅⁻ ⇒ SN = 7 sp^3d^3

ICl₂⁻ ⇒ SN = 5 sp^3d

ICl₄⁻ ⇒ SN = 6 sp^3d^2

SF₄ ⇒ SN = 5 sp^3d

NH₄⁺ ⇒ SN = 4 sp^3

ClF₃ ⇒ SN = 5 sp^3d

XeF₂ ⇒ SN = 5 sp^3d

XeF₄ ⇒ SN = 6 sp^3d^2

24. Consider the following reaction



Change in % of oxygen from phenol and product in filtrate is x %. Value of 2x is _____.

Answer (35)

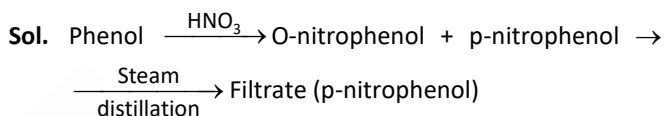

% of O in phenol = $\frac{16}{94} \times 100 = 17\%$

% of O in p-nitrophenol = $\frac{3 \times 16 \times 100}{139} = 34.5\%$

difference in % of O = 34.5 - 17 = 17.5%

x = 17.5, 2x = 35

25. Mole fraction of H₂O in 10% $\frac{W}{W}$ solution of urea in water is $x \times 10^{-3}$. Find value of x.

Answer (968)

Sol. Let mass of solution = 100 g
then $w_{\text{urea}} = 10$ g, $w_{\text{H}_2\text{O}} = 90$ g

$n_{\text{urea}} = \frac{10}{60} = \frac{1}{6}$, $n_{\text{H}_2\text{O}} = \frac{90}{18} = 5$

$\chi_{\text{H}_2\text{O}} = \frac{5}{\left(\frac{1}{6}\right) + 5} = 0.9677 = 968 \times 10^{-3}$

$x \times 10^{-3} = 968 \times 10^{-3}$

x = 968

Our Problem *Solvers* shine bright in **JEE 2025**

JEE (Advanced)

ADVAY
MAYANK
AIR 36



RUJUL
GARG
AIR 41



ARUSH
ANAND
AIR 64



JEE (MAIN)

SHREYAS
LOHIYA
AIR 6
Uttar Pradesh Topper
100 Overall



KUSHAGRA
BAINGAHA
AIR 7
Uttar Pradesh Topper
100 Overall



HARSSH
A GUPTA
AIR 15
Telangana Topper
100 Overall



MATHEMATICS

SECTION - A

Multiple Choice Questions: This section contains 20 multiple choice questions. Each question has 4 choices (1), (2), (3) and (4), out of which **ONLY ONE** is correct.

Choose the correct answer :

1. The sum of value $\sum_{n=1}^{10} \frac{528}{n(n+1)(n+2)}$ is equal to

- (1) 220
- (2) 65
- (3) 130
- (4) 260

Answer (3)

Sol.
$$S = \sum_{n=1}^{10} \frac{528}{n(n+1)(n+2)}$$

$$= 264 \sum_{n=1}^{10} \left[\frac{(n+2) - (n)}{n(n+1)(n+2)} \right]$$

$$= 264 \sum_{n=1}^{10} \left(\frac{1}{n(n+1)} - \frac{1}{(n+1)(n+2)} \right)$$

$$= 264 \left(\frac{1}{1 \times 2} - \frac{1}{2 \times 3} \right)$$

$$\left(\frac{1}{2 \times 3} - \frac{1}{3 \times 4} \right)$$

$$\dots$$

$$\left(\frac{1}{10 \times 11} - \frac{1}{11 \times 12} \right)$$

$$= 264 \left(\frac{1}{2} - \frac{1}{11 \times 12} \right) = 264 \times \frac{(66-1)}{11 \times 12}$$

$$= 130$$

2. Consider an equilateral triangle PQR , where $P(3, 5)$ and QR is $x + y = 4$. If the orthocentre of ΔPQR is (α, β) , then $9(\alpha + \beta)$ is equal to

- (1) 56
- (2) 48
- (3) 64
- (4) 36

Answer (2)

Sol. Foot of perpendicular $P' = \frac{x-3}{1} = \frac{y-5}{1} = -\frac{(8-4)}{2}$

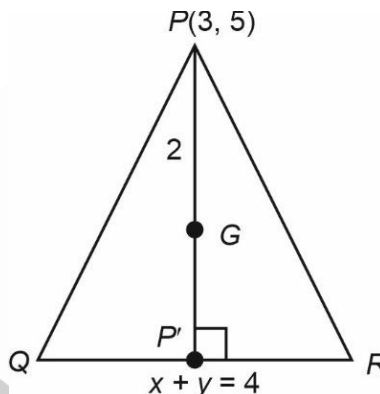

$\Rightarrow x = 1$
 $\Rightarrow y = 3$
 $\therefore P'(1, 3)$

Centroid = orthocenter

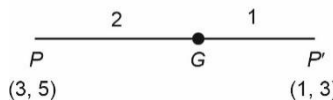

$G: \left(\frac{3+2}{3}, \frac{6+5}{3} \right)$
 $= \left(\frac{5}{3}, \frac{11}{3} \right)$

$9(\alpha + \beta) = \frac{16}{3} \times 9 = 48$

Our Problem Solvers shine bright in **JEE 2025**

JEE (Advanced)

| | | |
|---|---|--|
|  ADVAY MAYANK AIR 36 |  RUJUL GARG AIR 41 |  ARUSH ANAND AIR 64 |
|---|---|--|

JEE (MAIN)

| | | |
|--|--|---|
|  SHREYAS LOHIYA AIR 6 Uttar Pradesh Topper 100 Overall |  KUSHAGRA BAINGAHA AIR 7 Uttar Pradesh Topper 100 Overall |  HARSH A GUPTA AIR 15 Telangana Topper 100 Overall |
|--|--|---|

3. Let S_n is the sum of first n terms of an A.P. If $S_n = 3n^2 + 5n$. Then, the sum of square of first ten terms of the given A.P is
- (1) 15110 (2) 15220
 (3) 14202 (4) 14308

Answer (2)

Sol. $S_n = 3n^2 + 5n$

$$t_n = S_n - S_{n-1}$$

$$= 3n^2 + 5n - (3(n-1)^2 + 5(n-1))$$

$$= 3(2n-1) + 5 = 6n + 2$$

$$\sum_{r=1}^{10} t_r^2 = \sum_{r=1}^{10} 4(3r+1)^2$$

$$= 4 \left(\sum_{r=1}^{10} 9r^2 + 6 \sum_{r=1}^{10} r + 10 \right)$$

$$= 4 \left[9 \left(\frac{10 \times 11 \times 21}{6} \right) + 6 \left(\frac{10 \times 11}{2} \right) + 10 \right]$$

$$= 4[3465 + 330 + 10] = 15220$$

4. Consider a set $A = \{1, 2, 3, 5, 6\}$. The number of one-one functions $f: A \rightarrow A$ such that $f(1) \geq 3$, $f(3) \leq 4$ and $f(2) + f(3) = 5$ is equal to
- (1) 144 (2) 72
 (3) 36 (4) 24

Answer (2)

Sol. $f(1) \geq 3$
 $f(3) \leq 4$

$f(2) + f(3) = 5$
 $f(4), f(5), f(6)$ has no conditions.

| $(f(2), f(3))$ | $f(1)$ |
|----------------|-----------------------|
| (1, 4) | {3, 5, 6} → 3 choices |
| (4, 1) | {3, 5, 6} → 3 choices |
| (2, 3) | {4, 5, 6} → 3 choices |
| (3, 2) | {4, 5, 6} → 3 choices |

∴ Total function → $3 \times 4 \times 3!$
 $= 72$

5. The value of $\int_0^{\infty} \frac{\ln x}{x^2 + 4} dx$ is equal to

- (1) $\frac{\pi \ln 2}{4}$ (2) $\frac{\pi \ln 4}{2}$
 (3) $\frac{\pi \ln 2}{2}$ (4) $\frac{\pi \ln 4}{3}$

Answer (1)

Sol. $I = \int_0^{\infty} \frac{\ln x}{x^2 + 4} dx$

put $x = \frac{4}{u}$

$dx = -\frac{4}{u^2} du$

$I = \int_0^{\infty} \frac{\ln\left(\frac{4}{u}\right)}{\left(\frac{4}{u}\right)^2 + 4} \left(\frac{4}{u^2}\right) du$

$= \int_0^{\infty} \frac{\ln 4 - \ln u}{\frac{16}{u^2} + 4} \cdot \frac{4}{u^2} du$

$= \int_0^{\infty} \frac{\ln 4}{u^2 + 4} du - \int_0^{\infty} \frac{\ln u}{u^2 + 4} du$

$2I = \ln 4 \int_0^{\infty} \frac{1}{u^2 + 4} du = \ln 4 \times \frac{1}{2} \tan^{-1}\left(\frac{u}{2}\right) \Big|_0^{\infty}$

$= \ln 4 \times \frac{1}{2} \left(\frac{\pi}{2} - 0 \right) = \frac{\pi \ln 4}{4} = \frac{\pi \ln 2}{2}$

$I = \frac{\pi \ln 2}{4}$

6. If $\tan A$ and $\tan B$ are the roots of the equation $x^2 - 2x - 5 = 0$. Then, the value of $20 \sin^2\left(\frac{A+B}{2}\right)$ is
- (1) $5 + 3\sqrt{6}$ (2) $10 + 3\sqrt{10}$
 (3) $5 - 3\sqrt{2}$ (4) $10 - 3\sqrt{10}$

Answer (4)

Our Problem *Solvers* shine bright in **JEE 2025**

| JEE (Advanced) | | | JEE (MAIN) | | |
|--|--|---|--|---|--|
| ADVAY MAYANK AIR 36 | RUJUL GARG AIR 41 | ARUSH ANAND AIR 64 | SHREYAS LOHIYA AIR 6 <small>Uttar Pradesh Topper 100 Overall</small> | KUSHAGRA BAINGAHA AIR 7 <small>Uttar Pradesh Topper 100 Overall</small> | HARSH A GUPTA AIR 15 <small>Telangana Topper 100 Overall</small> |

Sol. $\tan A + \tan B = 2$

$\tan A \tan B = -5$

$\tan(A+B) = \frac{\tan A + \tan B}{1 - \tan A \tan B}$

$= \frac{2}{1 - (-5)} = \frac{2}{6} = \frac{1}{3}$

$\cos(A+B) = \frac{3}{\sqrt{10}}$

$2\sin^2\left(\frac{A+B}{2}\right) = 1 - \cos(A+B)$

$2\sin^2\left(\frac{A+B}{2}\right) = 1 - \frac{3}{\sqrt{10}}$

$20\sin^2\left(\frac{A+B}{2}\right) = 10\left(1 - \frac{3}{\sqrt{10}}\right)$

$= 10 - 3\sqrt{10}$

7. The value of $\int_{\frac{\pi}{6}}^{\frac{\pi}{3}} \frac{(4 - \operatorname{cosec}^2 x)}{\cos^4 x} dx$ is equal to

(1) $\frac{16\sqrt{3}}{9}$

(2) $\frac{32\sqrt{3}}{9}$

(3) $\frac{16}{\sqrt{3}}$

(4) 32

Answer (2)

Sol. Consider, $\frac{4 - \operatorname{cosec}^2 x}{\cos^4 x} = (4 - (1 + \cot^2 x))(\sec^2 x)^2$

$= \left(3 - \frac{1}{\tan^2 x}\right)(1 + \tan^2 x)(\sec^2 x)$

Put $u = \tan x$

$du = \sec^2 x dx$

$\Rightarrow I = \int_{\frac{1}{\sqrt{3}}}^{\sqrt{3}} \left(3 - \frac{1}{u^2}\right)(1 + u^2) dx$

$= \int_{\frac{1}{\sqrt{3}}}^{\sqrt{3}} (3u^2 + 2 - u^{-2}) dx$

$= \left(\frac{u^3}{3} + 2u - \frac{u^{-1}}{-1}\right) \Big|_{\frac{1}{\sqrt{3}}}^{\sqrt{3}}$

$= \frac{16\sqrt{3}}{3} - \frac{16\sqrt{3}}{9} = \frac{32\sqrt{3}}{9}$

8. Let $\vec{a} = \sqrt{7}\hat{i} + \hat{j} - \hat{k}$, $\vec{b} = \hat{j} + 2\hat{k}$, $\vec{r} \times \vec{a} + \vec{b} \times \vec{a} = \vec{0}$ and $\vec{r} \cdot \vec{a} = 0$. The value of $|3\vec{r}|^2$ is equal to

(1) 56

(2) 44

(3) 42

(4) 48

Answer (2)

Sol. $\vec{r} \times \vec{a} + \vec{b} \times \vec{a} = \vec{0}$

$\Rightarrow (\vec{r} + \vec{b}) \times \vec{a} = \vec{0}$

$(\vec{r} \cdot \vec{a} = 0 \therefore \vec{r} \neq -\vec{b})$

$\Rightarrow \vec{r} + \vec{b} = \lambda \vec{a}$

$\Rightarrow \vec{r} = \lambda \vec{a} - \vec{b}$

$\Rightarrow \vec{r} \cdot \vec{a} = \lambda a^2 - \vec{a} \cdot \vec{b}$

$\Rightarrow \lambda = \frac{\vec{a} \cdot \vec{b}}{a^2} = \frac{1-2}{9} = \frac{-1}{9}$

$\therefore \vec{r} = \frac{-1}{9} \vec{a} - \vec{b}$

$\Rightarrow |\vec{r}|^2 = \frac{a^2}{81} + b^2 + 2 \cdot \left(\frac{\vec{a}}{9}\right) \cdot (\vec{b})$

$= \frac{9}{81} + 5 - \frac{2}{9}$

$= \frac{1}{9} + 5 - \frac{2}{9}$

$= 5 - \frac{1}{9} = \frac{44}{9}$

$|3\vec{r}|^2 = 9|\vec{r}|^2 = 44$

Our Problem *Solvers* shine bright in **JEE 2025**

JEE (Advanced)

ADVAY
MAYANK
AIR 36



RUJUL
GARG
AIR 41



ARUSH
ANAND
AIR 64



JEE (MAIN)

SHREYAS
LOHIYA
AIR 6
Uttar Pradesh Topper
100 Overall



KUSHAGRA
BAINGAHA
AIR 7
Uttar Pradesh Topper
100 Overall



HARSH
A GUPTA
AIR 15
Telangana Topper
100 Overall



9. Let $f(x+y) = \frac{f(x)+f(y)}{3}$ and $f(0) = 3$. If $g(x) = 3 + e^x f(x)$. Then, the minimum value of $g(x)$ is
- (1) $2 + \frac{2}{e}$ (2) $3 - \frac{3}{e}$
 (3) $1 - \frac{1}{e}$ (4) $1 + \frac{1}{e}$

Answer (2)

Sol. $f\left(\frac{x+y}{3}\right) = \frac{f(x)+f(y)}{3}$

$$f'(x) = \lim_{h \rightarrow 0} \frac{f\left(\frac{3x+3h}{3}\right) - f(x)}{h}$$

$$= \lim_{h \rightarrow 0} \frac{f(3x) + f(3h) - f(x)}{h}$$

$$= \lim_{h \rightarrow 0} \frac{f(3x) + f(3h) - \left(f\left(\frac{3x+0}{3}\right)\right)}{h}$$

$$= \lim_{h \rightarrow 0} \frac{f(3x) + f(3h) - \left(\frac{f(3x) + f(0)}{3}\right)}{h}$$

$$f'(x) = \lim_{h \rightarrow 0} \frac{f(0+3h) - f(0)}{3h}$$

$$f'(x) = f'(0) = 3$$

$$f'(x) = 3$$

$$f(x) = 3x + k$$

also $f(0) = 0$

$$\Rightarrow f(x) = 3x$$

$$g(x) = 3 + e^x f(x)$$

$$g(x) = 3 + e^x (3x)$$

$$g'(x) = 3e^x + 3xe^x = 0$$

$$\Rightarrow 3e^x(1+x) = 0$$

$$\Rightarrow x = -1$$

$$g''(x) = 3e^x + 3e^x + 3xe^x$$

$$= 6e^x + 3xe^x$$

$$g''(-1) = \frac{6}{e} - \frac{3}{e} = \frac{3}{e} > 0$$

$$\Rightarrow \text{minima at } x = -1$$

$$g(-1) = 3 + e^{-1}(-3)$$

$$= 3 - \frac{3}{e}$$

10. Consider an Ellipse $E: \frac{x^2}{a^2} + \frac{y^2}{b^2} = 1$ with eccentricity $e = \frac{4}{5}$, focus at $(4,0)$ and the point $P(3, \alpha)$ lie on E . Then the area of the triangle POS (in sq. unit) is
- (1) $\frac{12}{5}$ (2) $\frac{13}{5}$
 (3) $\frac{24}{5}$ (4) $\frac{48}{5}$

Answer (3)

Sol.

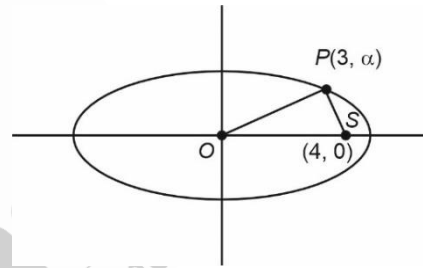

$$ae = 4 \qquad \left(\frac{4}{5}\right)^2 = 1 - \frac{b^2}{a^2}$$

$$\Rightarrow a = 5 \qquad \frac{16}{25} = 1 - \frac{b^2}{25}$$

$$\Rightarrow b = 3$$

$\Rightarrow P$ lie on ellipse:

$$\frac{9}{25} + \frac{\alpha^2}{9} = 1 \qquad \Rightarrow 81 + 25\alpha^2 = 9 \times 25$$

$$\Rightarrow \alpha^2 = \frac{9 \times 25 - 81}{25}$$

$$\alpha = \frac{12}{5}$$

$$\Rightarrow \Delta POS = \frac{1}{2} \times 4 \times \frac{12}{5} = \frac{24}{5}$$

Our Problem *Solvers* shine bright in **JEE 2025**

JEE (Advanced)

ADVAY
MAYANK
AIR 36



RUJUL
GARG
AIR 41



ARUSH
ANAND
AIR 64



JEE (MAIN)

SHREYAS
LOHIYA
AIR 6
Uttar Pradesh Topper
100 Overall



KUSHAGRA
BAINGAHA
AIR 7
Uttar Pradesh Topper
100 Overall



HARSH
A GUPTA
AIR 15
Telangana Topper
100 Overall



11. The shortest distance of the point (2, 3, 4) from the line

$$\frac{x-1}{2} = \frac{y-3}{-1} = \frac{z-2}{0} \text{ is equal to}$$

- (1) $\sqrt{2}$ (2) $\sqrt{5}$
(3) $\sqrt{\frac{21}{5}}$ (4) $\sqrt{7}$

Answer (3)

Sol. Any general point on Line $L: \frac{x-1}{2} = \frac{y-3}{-1} = \frac{z-2}{0}$ is

$$P(2\lambda + 1, -\lambda + 3, 2)$$

$$A(2, 3, 4)$$

Direction ratio of AP $(2\lambda - 1, -\lambda, -2)$

$$AP \perp L$$

$$2(2\lambda - 1) + (-1)(-\lambda) + 0(-2) = 0$$

$$4\lambda - 2 + \lambda = 0$$

$$5\lambda - 2 = 0$$

$$\lambda = \frac{2}{5}$$

$$|AP| = \sqrt{\left(\frac{4}{5} - 1\right)^2 + \left(-\frac{2}{5}\right)^2 + (-2)^2}$$

$$= \sqrt{\frac{1}{25} + \frac{4}{25} + 4}$$

$$= \sqrt{\frac{1}{5} + 4}$$

$$= \sqrt{\frac{21}{5}}$$

12. Letter is posted from either KANPUR or ANANTPUR. When envelope was upon, only "AN" was visible. The probability that it came from ANANTPUR is equal to

- (1) $\frac{9}{16}$ (2) $\frac{1}{11}$
(3) $\frac{10}{17}$ (4) $\frac{9}{13}$

Answer (3)

Sol. E_1 : The letter came from KANPUR

E_2 : The letter came from ANANTPUR

E : Visible letter is "AN"

$$P(E_1) = P(E_2) = \frac{1}{2}$$

$$P\left(\frac{A}{E_1}\right) = \frac{1}{5}$$

$$P\left(\frac{A}{E_2}\right) = \frac{2}{7}$$

$$P\left(\frac{E_2}{A}\right) = \frac{\frac{1}{2} \times \frac{2}{7}}{\frac{1}{2} \times \frac{1}{5} + \frac{1}{2} \times \frac{2}{7}} = \frac{10}{17}$$

13. If $\alpha = \frac{\pi}{4} + \sum_{p=1}^{11} \tan^{-1}\left(\frac{2^{p-1}}{1+2^{2p-1}}\right)$, then the value of $\tan \alpha$

is

- (1) 2^9 (2) 2^{10}
(3) 2^{11} (4) 2^{12}

Answer (3)

Sol. $\alpha = \frac{\pi}{4} + \sum_{p=1}^{11} \tan^{-1}\left(\frac{2^{p-1}}{1+2^{2p-1}}\right)$

$$\tan^{-1}\left(\frac{2^{p-1}}{1+2^{2p-1}}\right) = \tan^{-1}\left(\frac{2^p - 2^{p-1}}{1+2^p \cdot 2^{p-1}}\right)$$

$$\tan^{-1}(2^p) - \tan^{-1}(2^{p-1})$$

$$\text{Now, } \sum_{p=1}^{11} [\tan^{-1}(2^p) - \tan^{-1}(2^{p-1})]$$

$$= \tan^{-1}(2^1) - \tan^{-1}(2^0) + \tan^{-1}(2^2) - \tan^{-1}(2^1) + \dots + \tan^{-1}(2^{11}) - \tan^{-1}(2^{10})$$

$$= \tan^{-1}(2^{11}) - \tan^{-1}(2^0) = \tan^{-1}(2^{11}) - \tan^{-1}(1)$$

$$= \tan^{-1}(2^{11}) - \frac{\pi}{4}$$

$$\therefore \alpha = \tan^{-1}(2^{11})$$

$$\tan \alpha = 2^{11}$$

Our Problem *Solvers* shine bright in **JEE 2025**

JEE (Advanced)

ADVAY
MAYANK
AIR 36



RUJUL
GARG
AIR 41



ARUSH
ANAND
AIR 64



JEE (MAIN)

SHREYAS
LOHIYA
AIR 6
Uttar Pradesh Topper
100 Overall



KUSHAGRA
BAINGAHA
AIR 7
Uttar Pradesh Topper
100 Overall



HARSSH
A GUPTA
AIR 15
Telangana Topper
100 Overall



SECTION - B

Numerical Value Type Questions: This section contains 5 Numerical based questions. The answer to each question should be rounded-off to the nearest integer.

21. In the expansion of $\left(\frac{1}{x^3} - x^4\right)^n$, the sum of coefficient of x^7 & x^{14} is equal to 0. Then the value of n is

Answer (21)

Sol. $\left(\frac{1}{x^3} - x^4\right)^n$

$$t_{r+1} = {}^n C_r (x^{-3})^{n-r} (-x^4)^r$$

$$= {}^n C_r (-1)^r x^{7r-3n}$$

for coeff. x^7

$$\text{Now, } 7r_1 - 3n = 7$$

$$\Rightarrow r_1 = \frac{3n+7}{7}$$

$$\text{Coeff. is } {}^n C_{r_1} (-1)^{r_1}$$

for coeff. x^{14}

$$7r_2 - 3n = 14$$

$$r_2 = \frac{3n+14}{7} = \frac{3n+7}{7} + 1$$

$$r_2 = r_1 + 1 \text{ \& coeff. is } C_2 = {}^n C_{r_1+1} (-1)^{r_1+1}$$

$$C_1 + C_2 = 0$$

$${}^n C_{r_1} (-1)^{r_1} + {}^n C_{r_1+1} (-1)^{r_1+1} = 0$$

$${}^n C_{r_1} (-1)^{r_1} - {}^n C_{r_1+1} (-1)^{r_1} = 0 \quad \left\{ \because (-1)^{r_1+1} = -(-1)^{r_1} \right\}$$

$${}^n C_{r_1} = {}^n C_{r_1+1}$$

$$r_1 + r_1 + 1 = n$$

$$2r_1 + 1 = n$$

$$2\left(\frac{3n+7}{7}\right) + 1 = n$$

$$\Rightarrow n = 21$$

22. If $y = y(x)$ is the solution of the differential equation

$$x \sin\left(\frac{y}{x}\right) dy = \left(y \sin\left(\frac{y}{x}\right) - x\right) dx$$

$$\text{Given that } y(1) = \frac{\pi}{2} \text{ and } \alpha = \cos\left(\frac{y(e^{12})}{e^{12}}\right).$$

If the radius of the circle $x^2 + y^2 - 2px - 2p - \alpha - 2 = 0$ is r where $r \leq 6$. Then, the number of integral values of p is

Answer (9)

Sol. $x \sin\left(\frac{y}{x}\right) dy = \left(y \sin\left(\frac{y}{x}\right) - x\right) dx$

$$\sin\left(\frac{y}{x}\right) dy = \left(\frac{y}{x} \sin\left(\frac{y}{x}\right) - 1\right) dx$$

$$\frac{dy}{dx} = \frac{\frac{y}{x} \sin\left(\frac{y}{x}\right) - 1}{\sin\left(\frac{y}{x}\right)}$$

$$\text{Let } y = vx$$

$$\frac{dy}{dx} = v + x \frac{dv}{dx}$$

$$v + x \frac{dv}{dx} = \frac{v \sin v - 1}{\sin v}$$

$$x \frac{dv}{dx} = \frac{v \sin v - 1}{\sin v} - v$$

$$x \frac{dv}{dx} = \frac{v \sin v - 1 - v \sin v}{\sin v}$$

$$x \frac{dv}{dx} = \frac{-1}{\sin v}$$

$$-\sin v dv = \frac{dx}{x}$$

Our Problem *Solvers* shine bright in **JEE 2025**

JEE (Advanced)

ADVAY
MAYANK
AIR 36



RUJUL
GARG
AIR 41



ARUSH
ANAND
AIR 64



JEE (MAIN)

SHREYAS
LOHIYA
AIR 6
Uttar Pradesh Topper
100 Overall



KUSHAGRA
BAINGAHA
AIR 7
Uttar Pradesh Topper
100 Overall



HARSHH
A GUPTA
AIR 15
Telangana Topper
100 Overall



Integrating both sides

$$\cos V = \ln x + k$$

$$\cos\left(\frac{y}{x}\right) = \ln x + k$$

at $y(1) = \frac{\pi}{2}$

$$k = 0$$

$$\alpha = \cos\left(\frac{y(e^{12})}{e^{12}}\right)$$

$$\alpha = \ln(e^{12})$$

$$\alpha = 12$$

C: $x^2 + y^2 - 2px - 2p - \alpha - 2 = 0$

Put $\alpha = 12$

$$x^2 + y^2 - 2px - 2p - 14 = 0$$

one $r \leq 6$

$$\sqrt{p^2 + 2p + 14} \leq 6$$

$$p^2 + 2p + 14 \leq 36$$

$$p^2 + 2p - 22 \leq 0$$

$$p \in [-1 - \sqrt{23}, -1 + \sqrt{23}]$$

\Rightarrow Integral values of p are

$$-5, -4, -3, -2, -1, 0, 1, 2, 3$$

23.

24.

25.



Our Problem *Solvers* shine bright in **JEE 2025**

JEE (Advanced)

ADVAY
MAYANK
AIR 36



RUJUL
GARG
AIR 41



ARUSH
ANAND
AIR 64



SHREYAS
LOHIYA
AIR 6
Uttar Pradesh Topper
100 Overall



KUSHAGRA
BAINGAHA
AIR 7
Uttar Pradesh Topper
100 Overall



HARSH
A GUPTA
AIR 15
Telangana Topper
100 Overall

