

05/04/2026

Morning



Aakash

Medical | IIT-JEE | Foundations

Corporate Office : AESL, 3rd Floor, Incuspaze Campus-2, Plot-13, Sector-18, Udyog Vihar,
Gurugram, Haryana-122015

Memory Based Answers & Solutions

Time : 3 hrs.

for

M.M. : 300

JEE (Main)-2026 (Online) Phase-2

(Physics, Chemistry and Mathematics)

Don't guess your JEE Main score.

Calculate it Instantly

with our

JEE Main Score Calculator.

HOW TO GET YOUR SCORES

- Open your response sheet on the JEE Main Site
- Copy the link from the browser's Address bar
- Paste it into the required field in the Calculator



Scan the QR code
to know more.



jee-marks-calculator.aakash.ac.in/

Our Problem *Solvers* shine bright in **JEE 2025**

JEE (Advanced)

ADVAY
MAYANK
AIR 36



RUJUL
GARG
AIR 41



ARUSH
ANAND
AIR 64



SHREYAS
LOHIYA
AIR 6
Uttar Pradesh Topper
100 Overall



KUSHAGRA
BAINGAHA
AIR 7
Uttar Pradesh Topper
100 Overall



HARSSH
A GUPTA
AIR 15
Telangana Topper
100 Overall



PHYSICS

SECTION - A

Multiple Choice Questions: This section contains 20 multiple choice questions. Each question has 4 choices (1), (2), (3) and (4), out of which **ONLY ONE** is correct.

Choose the correct answer:

1. As shown in figure, the ratio of T_1 and T_2 is

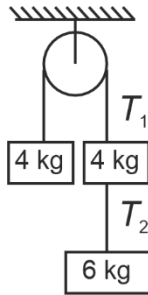

- (1) 5/3
- (2) 4/3
- (3) 10/3
- (4) 6/3

Answer (1)

Sol. $a = \frac{(10g - 4g)}{14} = \frac{6g}{14} = \frac{3g}{7}$

$6g - T_2 = 6 \times \frac{3g}{7}$

$\Rightarrow T_2 = 6g - 3 \times \frac{6g}{7} = 6g \times \frac{4}{7}$

And $T_1 - 4g = 4 \times \frac{3g}{7}$

$T_1 = 4g \left(1 + \frac{3}{7}\right) = 4g \times \frac{10}{7}$

$\frac{T_1}{T_2} = \frac{5}{3}$

2. For the circuit shown below, find current across AB (I_{AB})

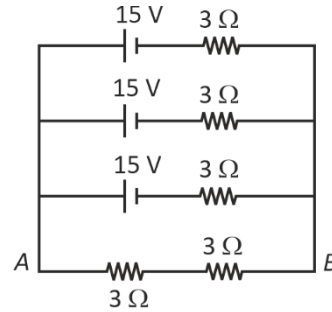

- (1) $\frac{10}{7}$ A
- (2) $\frac{13}{7}$ A
- (3) $\frac{11}{7}$ A
- (4) $\frac{15}{7}$ A

Answer (4)

Sol. $\frac{1}{r_0} = \frac{1}{3} + \frac{1}{3} + \frac{1}{3} = 1$

$\Rightarrow r_0 = 1 \Omega$

$\epsilon_0 = \frac{\epsilon(r^2) \times 3}{3r^2} = \epsilon = 15 \text{ V}$

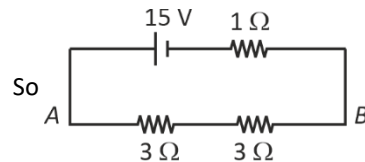

So $I_{AB} = \frac{15}{7}$

Our Problem Solvers shine bright in **JEE 2025**

JEE (Advanced)

ADVAY
MAYANK
AIR 36



RUJUL
GARG
AIR 41



ARUSH
ANAND
AIR 64



JEE (MAIN)

SHREYAS
LOHIYA
AIR 6
Uttar Pradesh Topper
100 Rank in Overall



KUSHAGRA
BAINGAHA
AIR 7
Uttar Pradesh Topper
100 Rank in Overall



HARSH
A GUPTA
AIR 15
Telangana Topper
100 Rank in Overall



3. Speed of light in the prism = 2×10^8 m/s. Then find minimum deviation through the prism.

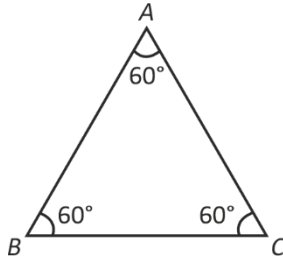

- (1) $2\sin^{-1}\left(\frac{3}{4}\right) - 30^\circ$ (2) $2\sin^{-1}\left(\frac{3}{4}\right) + 30^\circ$
 (3) $2\sin^{-1}\left(\frac{3}{4}\right) + 60^\circ$ (4) $2\sin^{-1}\left(\frac{3}{4}\right) - 60^\circ$

Answer (4)

Sol. $\mu = \frac{\sin\left(\frac{\delta_m + A}{2}\right)}{\sin\left(\frac{A}{2}\right)}$

$A = 60^\circ, u = \frac{3 \times 10^8}{2 \times 10^8} = \frac{3}{2}$

$\frac{3}{2} = \frac{\sin\left(\frac{\delta_m + 60^\circ}{2}\right)}{\sin\left(\frac{60^\circ}{2}\right)}$

$\delta = 2\sin^{-1}\left(\frac{3}{4}\right) - 60^\circ$

4. Select the quantity with matching dimensions of $ML^2 T^{-4} A^{-2}$.

- (1) $\frac{R}{\sqrt{LC}}$ (2) $\frac{1}{R} \sqrt{\frac{L}{C}}$
 (3) $\frac{R}{LC}$ (4) $\frac{C}{\sqrt{LR}}$

Answer (1)

Sol. $R = \frac{V}{i} = \frac{ML^2 T^{-2}}{A^2 T} = ML^2 T^{-3} A^{-2}, \sqrt{LC} = T$

$R_{req. \text{ dimension}} = \frac{R}{\text{time}} \Rightarrow \text{option-1}$

5. Two points A and B are 16 km from surface of earth.

Acceleration due to gravity at A & B is g_A & g_B , then $\frac{g_A}{g_B} =$

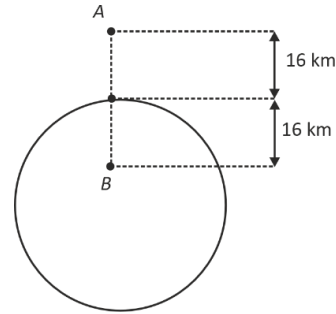

- (1) $\frac{1}{2}$ (2) $\frac{149}{200}$
 (3) $\frac{398}{399}$ (4) $\frac{441}{442}$

Answer (3)

Sol. Ratio = $\frac{g_0 \left(1 - \frac{2 \times 16}{6400}\right)}{g_0 \left(1 - \frac{16}{6400}\right)} = \frac{6400 - 32}{6400 - 16} = \frac{400 - 2}{400 - 1} = \frac{398}{399}$

6. Young's modulus of wire is Y. Keeping material same, if radius of wire is doubled while length is halved. Then new value of Young's modulus is

- (1) 2Y (2) 4Y
 (3) Y (4) $\frac{Y}{2}$

Answer (3)

Sol. Young's modulus depends on material.

7. In circuit given below, $L_1 = L_2 = L_3$ & total energy stored in system is E_1 & energy stored in L_2 is E_2 . Then find $\frac{E_1}{E_2}$

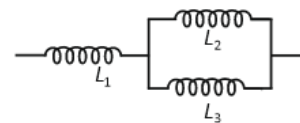

- (1) 6 (2) 4
 (3) 1 (4) 3

Answer (1)

Our Problem Solvers shine bright in **JEE 2025**

JEE (Advanced)

JEE (MAIN)

ADVAY MAYANK AIR 36 RUJUL GARG AIR 41 ARUSH ANAND AIR 64

SHREYAS LOHIYA AIR 6 Uttar Pradesh Topper 100 KUSHAGRA BAINGAHA AIR 7 Uttar Pradesh Topper 100 HARSH A GUPTA AIR 15 Telangana Topper 100

Sol. Energy in L_3 will also be E_2

& in L_1 it will be $4E_2$

$$\therefore 2E_2 + 4E_2 = E_1$$

$$\Rightarrow 6E_2 = E_1$$

$$\therefore \frac{E_1}{E_2} = 6$$

8. Breaking stress of both wires is $1.2 \times 10^8 \text{ N/m}^2$ area of cross section of both wire is 0.008 cm^2 .

Find maximum value of m such that no wire breaks. ($g = 10 \text{ m/s}^2$)

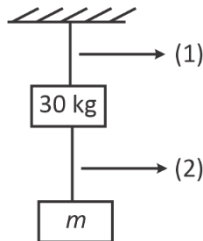

(1) 4.1 kg

(2) 6.6 kg

(3) 8.7 kg

(4) 9 kg

Answer (2)

Sol. Wire 1 would tend to break first

$$\therefore \frac{30 + mg}{A} = 1.2 \times 10^8$$

$$\Rightarrow 30 + 10m = 1.2 \times 10^8 \times 0.008 \times 10^{-4}$$

$$\Rightarrow 10m = 1.2 \times 10 \times 8 - 30$$

$$m = 6.6 \text{ kg}$$

9. In a region where electric field exist as $-E_0 \hat{i}$ (V/m). Initial (at $t = 0$) velocity of particle of mass m is $4V_0 \hat{i}$.

$$\lambda_0 = \frac{h}{4mv_0} \text{ at instant } t = 0, \text{ then find } \lambda \text{ in terms of } \lambda_0 \text{ at}$$

time instant t .

$$(1) \lambda = \frac{h\lambda_0}{h + qE_0\lambda_0 t}$$

$$(2) \lambda = \frac{h\lambda_0}{h - qE_0\lambda_0 t}$$

$$(3) \lambda = \frac{h\lambda_0}{(h + 2E_0q\lambda_0 t)}$$

$$(4) \lambda = \frac{h\lambda_0}{\left(h + \frac{qE_0\lambda_0 t}{2}\right)}$$

Answer (2)

$$\text{Sol. } \lambda = \frac{h}{p}$$

at $t = 0$

$$P = 4mV_0.$$

$$\text{So } \lambda_0 = \frac{h}{4mV_0}$$

At t

$$V = 4V_0 - \left(\frac{qE_0}{m}\right)t$$

$$P = 4mV_0 - \frac{qE_0}{t}$$

$$\lambda = \frac{h}{4mV_0 - qE_0 t} = \frac{h}{\left(\frac{h}{\lambda_0} - qE_0 t\right)}$$

$$\Rightarrow \lambda = \frac{h\lambda_0}{h - qE_0\lambda_0 t}$$

10. In thermodynamics, with usual symbols two expressions are given

$$\text{Expression 1: } \Delta U = \mu C_v \Delta T + \frac{\mu R \Delta T}{\gamma - 1}$$

$$\text{Expression 2: } \gamma f = f + 2$$

Then

(1) E1 is correct and E2 is incorrect

(2) E1 is incorrect and E2 is correct

(3) E1, E2 are correct

(4) E1, E2 are incorrect

Answer (2)

Sol. Theoretical.

Our Problem Solvers shine bright in **JEE 2025**

JEE (Advanced)

ADVAY
MAYANK
AIR 36



RUJUL
GARG
AIR 41



ARUSH
ANAND
AIR 64



SHREYAS
LOHIYA
AIR 6
Uttar Pradesh Topper
100



KUSHAGRA
BAINGAHA
AIR 7
Uttar Pradesh Topper
100



HARSH
A GUPTA
AIR 15
Telangana Topper
100



11. Moment of inertia of rod about an axis passing through point at distance $\frac{l}{4}$ from center and perpendicular to rod is (The uniform rod is of mass m and length l)

- (1) $\frac{8}{63} ml^2$
- (2) $\frac{3}{7} ml^2$
- (3) $\frac{7}{44} ml^2$
- (4) $\frac{7}{48} ml^2$

Answer (4)

Sol. $I = \frac{ml^2}{12} + m\left(\frac{l}{4}\right)^2 = \left(\frac{1}{12} + \frac{1}{16}\right)ml^2 = \frac{7}{48} ml^2$

12. For a wave, equation is given as $y = 3 \sin(\omega t - 0.018x + \pi/4)$. Find the minimum distance between consecutive crest.

- (1) $\frac{200}{3} \pi$ (m)
- (2) $\frac{400}{3} \pi$ (m)
- (3) $\frac{1000}{9} \pi$ (m)
- (4) $\frac{500}{9} \pi$ (m)

Answer (3)

Sol. Distance between two consecutive crest is λ .

So, $\lambda = \frac{2\pi}{k} = \frac{2\pi}{0.018}$
 $\Rightarrow \lambda = \frac{1000\pi}{9} \text{ m.}$

13. Both LED's will switch on in which of the following option:

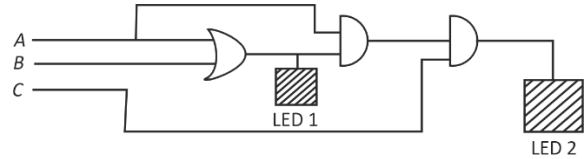

- (1)

A	B	C
1	1	0
- (2)

A	B	C
1	0	0
- (3)

A	B	C
1	0	1
- (4)

A	B	C
0	1	1

Answer (3)

Sol. For $A = 1$ $B = 0$ and $C = 1$

Both LEDs will switch on

14. A ball is dropped from 18 m high tower. Find distance of ball from ground when the speed of ball becomes equal to magnitude of acceleration of ball ($g = 10 \text{ m/s}^2$)

- (1) 8
- (2) 18
- (3) 13
- (4) 10

Answer (3)

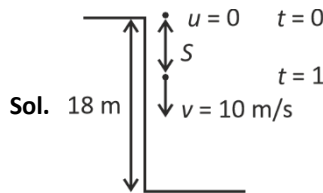

Sol. 18 m
 $S = \frac{1}{2} \times 10 \times 1^2 = 5$

\therefore Distance from ground will be 13 m.

Our Problem Solvers shine bright in **JEE 2025**

JEE (Advanced)

JEE (MAIN)

ADVAY MAYANK AIR 36		RUJUL GARG AIR 41		ARUSH ANAND AIR 64	
-------------------------------	--	-----------------------------	--	------------------------------	--

SHREYAS LOHIYA AIR 6 Uttar Pradesh Topper 100		KUSHAGRA BAINGAHA AIR 7 Uttar Pradesh Topper 100		HARSSH A GUPTA AIR 15 Telangana Topper 100	
---	--	--	--	--	--

15. On the top surface of a cube (length = 5 cm) force F is acting tangentially. Lower surface is fixed, then find shifting x .

[Modulus of rigidity $\eta = 10^5$ (SI unit)]

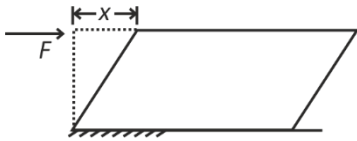

(1) $x = \frac{F}{2500}$

(2) $x = \frac{F}{5000}$

(3) $x = \frac{F}{4000}$

(4) $x = \frac{F}{8000}$

Answer (2)

Sol. $\frac{F \cdot h}{A \cdot x} = \eta$

$$\Rightarrow x = \frac{F \times 5 \times 10^{-2}}{25 \times 10^{-4} \times 10^5}$$

$$\Rightarrow x = \frac{F}{5000}$$

16. 10 VSD matches with 9 MSD in a vernier calliper. 1 MSD is of 1 mm. When no reading is taken, the zero of vernier scale is just right of zero of main scale and 7th VSD matches with one MSD then zero error is

- (1) 0.7 cm, +ve (2) 0.7 cm, -ve
(3) 0.7 mm, -ve (4) 0.7 mm, +ve

Answer (4)

Sol. $LC = 0.1 \text{ mm}$

Error = 0.7 mm

17. In circuit given below, current in circuit is i_0 . If angular frequency is changed from ω_0 to $\frac{\omega_0}{8}$ the current becomes

$\frac{i_0}{4}$. Find $\frac{1}{\omega_0 CR}$

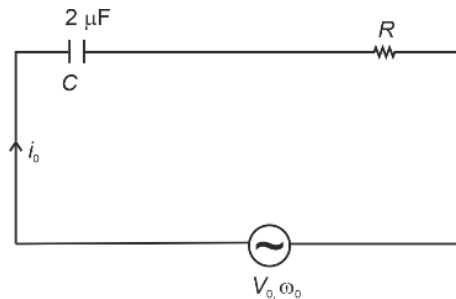

(1) $\sqrt{\frac{5}{16}}$

(2) $\sqrt{\frac{42}{13}}$

(3) $\sqrt{\frac{51}{38}}$

(4) $\sqrt{\frac{3}{2}}$

Answer (1)

Sol. $i_0 = \frac{V_0}{\sqrt{R^2 + X_L^2}}$

And $\frac{i_0}{4} = \frac{V_0}{\sqrt{R^2 + X_C^2 64}}$

$$\Rightarrow 4 = \frac{\sqrt{R^2 + X_L^2 64}}{\sqrt{R^2 + X_C^2}}$$

18. In hydrogen atom an electron is revolving in 4th Bohr's orbit. Find wavelength of the incident radiation to excite this electron to 16th Bohr's orbit. [Use $hc = 1240 \text{ nm} \cdot \text{ev}$.]

- (1) 1556 nm. (2) 400 nm.
(3) 800 nm. (4) 2000 nm.

Answer (1)

Our Problem Solvers shine bright in **JEE 2025**

JEE (Advanced)

ADVAY
MAYANK
AIR 36



RUJUL
GARG
AIR 41



ARUSH
ANAND
AIR 64



SHREYAS
LOHIYA
AIR 6
Uttar Pradesh Topper
100



KUSHAGRA
BAINGAHA
AIR 7
Uttar Pradesh Topper
100



HARSSH
A GUPTA
AIR 15
Telangana Topper
100



Sol. $\Delta E = E_0 \left[\frac{1}{16} - \frac{1}{256} \right] = \frac{hc}{\lambda}$
 $\Rightarrow E_0 \left(\frac{15}{256} \right) = \frac{hc}{\lambda}$
 $\Rightarrow \lambda = \frac{1240 \times 256}{13.6 \times 15} = 1556 \text{ nm}$

19.
20.

SECTION - B

Numerical Value Type Questions: This section contains 5 Numerical based questions. The answer to each question should be rounded-off to the nearest integer.

21. In a YDSE setup in air, fringe width is $2.4 \mu\text{m}$. If we submerge the setup in a liquid of refractive index 1.2 then find the new fringe width (in μm).

Answer (2)

Sol. $\Delta w = \frac{\lambda D}{d}$

But in case of medium with $m = 1.2$

$\Delta w' = \frac{\lambda D}{1.2 d}$

So $\frac{\Delta w'}{\Delta w} = \frac{\lambda D d}{1.2 d \times \lambda D} = \frac{1}{1.2}$

$\Rightarrow \Delta w' = \left(\frac{2.4}{1.2} \right) \mu\text{m} = 2 \mu\text{m}$

22. A particle moving uniformly enters a region having uniform magnetic field $(3\hat{i} + 2\hat{j})T$. Its acceleration is $\left(4\hat{i} - \frac{x}{2}\hat{j} \right) \text{ m/s}^2$. Find the value of x .

Answer (12)

Sol. As the acceleration and magnetic field are in x - y plane so velocity must be in z direction

So $\frac{q(v\hat{k}) \times (3\hat{i} + 2\hat{j})}{m} = \left(4\hat{i} - \frac{x}{2}\hat{j} \right)$

$\Rightarrow \frac{qv}{m} (3\hat{j} - 2\hat{i}) = 4\hat{i} - \frac{x}{2}\hat{j}$

Clearly $\frac{qv}{m} = -2$

So acceleration will be

$(4\hat{i} - 6\hat{j}) = \left(4\hat{i} - \frac{x}{2}\hat{j} \right)$

Clearly $x = 12$

23. Two microscopes gives same magnification in which objective lens are same and eyepiece of 2 is exactly half of eyepiece 1 which is equiconvex. Then $\frac{L_2}{L_1}$ is

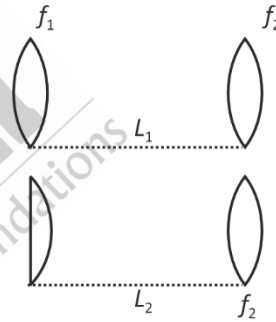

Answer (2)

Sol. $M = \frac{DL}{f_0 f_e} \Rightarrow \frac{L_1}{f_1} = \frac{L_2}{f_1'}; \frac{1}{f} = (\mu - 1) \left(\frac{1}{R_1} + \frac{1}{R_2} \right)$

$\frac{1}{f_1} = \frac{2(\mu - 1)}{R}$

$\frac{L_2}{L_1} = 2; \frac{1}{f_1'} = \frac{2(\mu - 1)}{R} \Rightarrow 2f_1 = f_1'$

24.
25.

Our Problem Solvers shine bright in **JEE 2025**

JEE (Advanced)

ADVAY MAYANK AIR 36		RUJUL GARG AIR 41		ARUSH ANAND AIR 64	
-------------------------------	--	-----------------------------	--	------------------------------	--

JEE (MAIN)

SHREYAS LOHIYA AIR 6 Uttar Pradesh Topper 100		KUSHAGRA BAINGAHA AIR 7 Uttar Pradesh Topper 100		HARSSH A GUPTA AIR 15 Telangana Topper 100	
---	--	--	--	--	--