

FINAL TEST SERIES for NEET-2023

MM : 720

Test-10

Time : 3 Hrs. 20 Mins.

Mock Test for NEET (Complete Syllabus of Class XI & XII)**Instructions for Paper (ΣXXIIVT10β) :**

- There are two sections in each subject, i.e. Section-A & Section-B. You have to attempt all 35 questions from Section-A & only 10 questions from Section-B out of 15.
- Each question carries 4 marks. For every wrong response 1 mark shall be deducted from the total score. Unanswered / unattempted questions will be given no marks.
- Use blue/black ballpoint pen only to darken the appropriate circle.
- Mark should be dark and completely fill the circle.
- Dark only one circle for each entry.
- Dark the circle in the space provided only.
- Rough work must not be done on the Answer sheet and do not use white-fluid or any other rubbing material on the Answer sheet. (ΣXXIIVT10β)

PHYSICS

Choose the correct answer :

SECTION - A

- Three identical non conducting spheres, each of charge $1 \mu\text{C}$ uniformly distributed and radius 1 m are kept such that each touches the other two. The magnitude of electric force on any sphere due to the other two will be
 - $5.6 \times 10^{-3} \text{ N}$
 - $4.1 \times 10^{-3} \text{ N}$
 - $6.8 \times 10^{-3} \text{ N}$
 - $3.9 \times 10^{-3} \text{ N}$
- A stone of mass 4 kg is whirled in a horizontal circle (in gravity free space) by attaching it to a 169 m long string. The string can withstand a maximum tension of 4 N. The maximum speed of revolution of the stone such that the string does not break is

- 10 m/s
 - 13 m/s
 - 16 m/s
 - 12 m/s
- The upper portion of an inclined plane is smooth and lower portion is rough. A particle slides down from rest from the top and just comes to rest at the foot. If the ratio of the smooth length to the rough length is $m : n$, the coefficient of friction is (α : angle of inclination)
 - $\left(\frac{m+n}{n}\right)\tan\alpha$
 - $\left(\frac{m+n}{n}\right)\cot\alpha$
 - $\left(\frac{m-n}{n}\right)\cot\alpha$
 - $\frac{1}{2}$

4. Two blocks A and B of masses 2 kg and 4 kg respectively are interconnected by an ideal spring of spring constant 200 N/m placed on a smooth horizontal surface. If the spring is initially unstretched and block B is given a rightward velocity 10 m/s , then the maximum extension attained in the spring will be

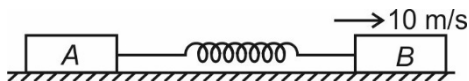

- (1) $\frac{2}{\sqrt{6}}\text{ m}$ (2) 2 m
 (3) $\frac{\sqrt{6}}{7}\text{ m}$ (4) 1.89 m
5. A square loop and a long straight wire are situated in a common plane such that one edge of the square is parallel to the wire. The mutual inductance between the wire and loop is

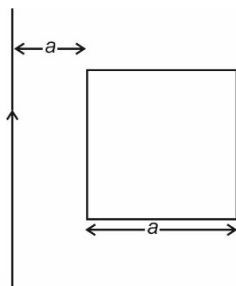

- (1) $\frac{\mu_0 a}{4\pi} \ln(2)$ (2) $\frac{\mu_0 a}{2\pi} \ln(2)$
 (3) $\frac{\mu_0 a}{\pi}$ (4) $\frac{\mu_0 a}{2\pi}$
6. A face of a prism of refracting angle 30° is silvered. A ray of light is incident on the other face at angle of incidence 45° . After refraction from the silvered face, the ray retraces its path. The index of refraction of prism will be
- (1) 4 (2) 2
 (3) $\sqrt{2}$ (4) $\frac{1}{\sqrt{2}}$
7. A charge Q is divided into two charges q_1 and q_2 , separated by a distance r . The force of repulsion between them will be maximum when

- (1) $q_1 = \frac{Q}{4}$ (2) $q_2 = \frac{Q}{8}$
 (3) $q_1 = \frac{Q}{2}$ (4) $q_2 = \frac{Q}{6}$

8. If \vec{A} , \vec{B} and \vec{C} are three vectors of magnitudes 12 units, 5 units and 13 units. And $\vec{A} + \vec{B} + \vec{C} = 0$, then angle between \vec{A} and \vec{B} is

- (1) $\frac{\pi}{4}$ (2) $\frac{\pi}{2}$
 (3) $\frac{\pi}{3}$ (4) $\frac{\pi}{6}$

9. A particle is moving on a circular path of radius R with uniform speed u . The displacement of the particle when the radius vector rotates by an angle 30° is

- (1) R (2) $R\frac{\sqrt{3}}{2}$
 (3) $2R\sin(15^\circ)$ (4) $R\sin(15^\circ)$

10. A calorimeter contains 100 g of ice at -20°C and $x\text{ g}$ of water at 80°C is added to the calorimeter such that the final contents of the calorimeter are in thermal equilibrium with 40°C mercury. The value of (x) is

- (1) 325 (2) 400
 (3) 100 (4) 60

11. Consider the following two statements.

- (a) The binding energy per nucleon is practically independent of mass number for nuclei of middle mass number ($30 < A < 170$).
 (b) Binding energy per nucleon is lower for both light nuclei ($A < 30$) and heavy nuclei ($A > 170$)

The correct statement(s) is/are

- (1) Only (a) (2) Only (b)
 (3) Both (a) and (b) (4) Neither (a) nor (b)

12. A parallel beam of monochromatic light of wavelength 600 nm passes through a slit of width 0.4 mm . The angular divergence in which most of the light is diffracted is

- (1) $3 \times 10^{-3}\text{ rad}$
 (2) $2 \times 10^{-3}\text{ rad}$
 (3) $4 \times 10^{-3}\text{ rad}$
 (4) $5 \times 10^{-3}\text{ rad}$

13. For a plane electromagnetic wave, time average of which among the following is zero?

- (1) Electric field
 (2) Magnetic energy
 (3) Electric energy
 (4) All of these

14. The heat absorbed by a system in going through a cyclic process shown in figure is

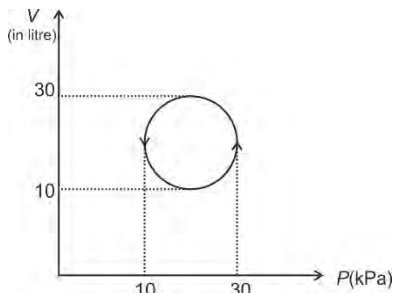

- (1) $400 \pi \text{ J}$ (2) 400 J
 (3) $200 \pi \text{ J}$ (4) $100 \pi \text{ J}$
15. The length of a metal wire is l_1 when the tension in it is T_1 and l_2 when the tension in it is T_2 then the unstretched length of the wire is

(1) $\frac{T_2 l_2 - T_1 l_1}{T_2 - T_1}$ (2) $\frac{T_2 l_2 - T_1 l_1}{T_1 + T_2}$
 (3) $\frac{T_2 l_1 - T_1 l_2}{T_1 + T_2}$ (4) $\frac{T_2 l_1 - T_1 l_2}{T_2 - T_1}$

16. A body falls freely from rest for 4 s. The average speed will be ($g = 10 \text{ m/s}^2$)
- (1) 20 m/s (2) 10 m/s
 (3) 40 m/s (4) 80 m/s
17. ABCD represents a uniform square lamina as shown in the figure. The moment of inertia along the corresponding axis have been indicated then the ratio $\frac{I_1 + I_2}{I_3}$ is

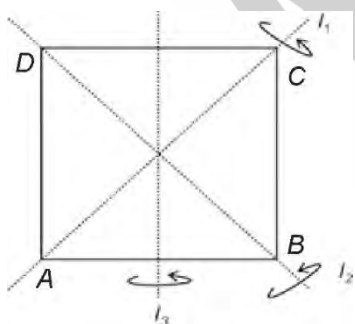

- (1) 1 : 4 (2) 4 : 3
 (3) 1 : 1 (4) 2 : 1
18. A nucleus of ${}^9_4\text{Be}$ absorbs an alpha particle and emits a neutron. The resulting nucleus will be

- (1) ${}^{13}_5\text{C}$
 (2) ${}^{12}_6\text{C}$
 (3) ${}^{13}_6\text{C}$
 (4) ${}^8_4\text{B}$

19. Photons of wavelength 660 nm are emitted from a 60 Watt lamp. What is the number of photons emitted per second?

- (1) 2×10^{16} (2) 2×10^{28}
 (3) 2×10^{20} (4) 2×10^{22}

20. If $A = 1, B = 0$, then the value of Boolean algebra $A + \overline{B}$ equals to the value of

- (1) A (2) B
 (3) \overline{A} (4) $\overline{A+B}$

21. The angle of incidence at which reflected light is totally polarized for a ray travelling from air to glass (refractive index n), is

- (1) $\sin^{-1}(n)$ (2) $\sin^{-1}\left(\frac{1}{n}\right)$
 (3) $\tan^{-1}\left(\frac{1}{n}\right)$ (4) $\tan^{-1}(n)$

22. A double convex lens is made of glass which has refractive index 1.55 for violet rays and 1.50 for red rays. If the focal length for violet rays is 20 cm, the focal length for red rays will be

- (1) 9 cm (2) 28 cm
 (3) 20 cm (4) 22 cm

23. An object is placed on the principal axis of a concave mirror of focal length 10 cm at a distance of 8 cm from the pole. Find the position and the nature of the image.

- (1) 40 cm, virtual
 (2) 40 cm, real
 (3) 20 cm, virtual
 (4) 20 cm, real

24. In an adiabatic expansion the product of pressure and volume

- (1) Decreases
 (2) Increases
 (3) Remains constant
 (4) First increases then decreases

25. A gaseous mixture consist of 16 g of helium and 16 g of oxygen. The ratio $\frac{C_p}{C_v}$ of the mixture is

- (1) 1.62
 (2) 1.59
 (3) 1.54
 (4) 1.4

26. The frequency of a stretched uniform wire under tension is in resonance with the fundamental frequency of a closed tube. If tension in the wire is increased by 8 N, it is in resonance with the first overtone of the closed tube. The initial tension in the wire is
- (1) 1 N (2) 4 N
(3) 8 N (4) 16 N
27. Gravel is falling on a conveyor belt at the rate of 5 kg/s. The extra power required to move the belt with a velocity 4 m/s is
- (1) 16 W (2) 80 W
(3) 10 W (4) 40 W
28. Masses 1 kg, 1.5 kg, 2 kg and M kg are situated at (2, 1, 1), (1, 2, 1), (2, -2, 1) and (-1, 4, 3). If their centre of mass is situated at $(1, 1, \frac{3}{2})$, the value of M is
- (1) 1 kg (2) 2 kg
(3) 1.5 kg (4) 3 kg
29. The gravitational potential energy of three objects of masses 1 kg, 2 kg and 3 kg placed at the vertices of an equilateral triangle of side 20 cm is
- (1) -3.7×10^{-12} J (2) -3.7×10^{-9} J
(3) $+3.2 \times 10^{-10}$ J (4) $+3.2 \times 10^{-12}$ J
30. Match the following (symbols have usual meanings).

	List-I		List-II
(A)	Perfectly elastic collision	(P)	$e = 0$
(B)	Inelastic collision	(Q)	$0 < e < 1$
(C)	Explosion	(R)	$e = 1$
(D)	Perfectly inelastic collision	(S)	Final K.E > Initial K.E

- (1) A → R, B → Q, C → S, D → P
(2) A → Q, B → R, C → S, D → P
(3) A → S, B → Q, C → P, D → R
(4) A → P, B → Q, C → R, D → S
31. The contribution of S. Chandrasekhar to physics is
- (1) Cosmic radiation
(2) Nuclear model of the atom
(3) Laser
(4) Structure and evolution of stars

32. A large open top container of negligible mass and uniform cross sectional area A has a small hole of cross sectional area a in its side wall near the bottom. The container is kept over a smooth horizontal floor and contains a liquid of density ρ and mass m_0 . Assuming that the liquid starts flowing through the hole, the acceleration of the container will be
- (1) $\frac{2ag}{A}$ (2) $\frac{ag}{A}$
(3) $\frac{2Ag}{a}$ (4) $\frac{Ag}{a}$
33. Thermal stress does not depend upon
- (1) Nature of the material
(2) Coefficient of linear expansion
(3) Young's modulus
(4) Length of the rod
34. The balancing lengths of potentiometer wire are l_1 and l_2 when two cells of emf E_1 and E_2 are connected in secondary circuit in series first to help each other and next to oppose each other $\frac{E_1}{E_2}$ is equal to ($E_1 > E_2$)
- (1) $\frac{l_1}{l_2}$ (2) $\frac{l_1 - l_2}{l_1 + l_2}$
(3) $\frac{l_1 + l_2}{l_1 - l_2}$ (4) $\frac{l_2}{l_1}$
35. A current of 1 A is made to pass through two resistances 1 Ω and 2 Ω connected in parallel. The current flowing through 2 Ω resistor will be
- (1) $\frac{1}{3}$ A (2) 1 A
(3) $\frac{2}{3}$ A (4) 3 A

SECTION - B

36. The power factor of the circuit shown in the figure is $\frac{1}{\sqrt{2}}$. The capacitive reactance of the circuit is

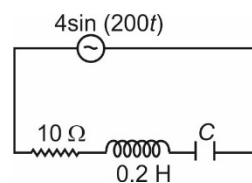

- (1) 30 Ω (2) 50 Ω
(3) 40 Ω (4) Either (1) or (2)

37. The amplifiers *A*, *B* and *C* are connected in series. If the voltage gain of *A*, *B* and *C* are 10, 15 and 20 respectively and input signal 2 mV peak value. Then the output signal voltage's peak value will be

- (1) 6 V (2) 5 V
(3) 3 V (4) 4 V

38. Arrange red light, blue light, green light and yellow light in increasing order of resolving power.

- (1) Red, Green, Blue, Yellow
(2) Red, Blue, Yellow, Green
(3) Blue, Yellow, Green, Red
(4) Red, Yellow, Green, Blue

39. Length, breadth and height of a cuboid are measured as 1.61 m, 2.2 m and 3.1 m. The volume of cuboid up to correct number of significant figures is

- (1) 10.98 m³ (2) 1.1 × 10¹ m³
(3) 10.9 m³ (4) 10.81 m³

40. A wire carrying current *i* is shaped as shown in the figure. The magnetic field at the origin is (*R* : Radius of circular section)

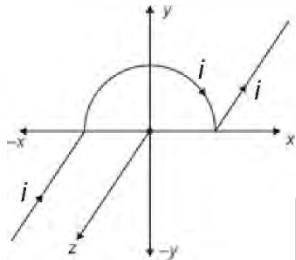

- (1) $\frac{\mu_0 i}{4\pi R}$ (2) $\frac{\mu_0 i}{2\pi R}$
(3) $\frac{\mu_0 i}{4R}$ (4) $\frac{\mu_0 i}{2R}$

41. A particle starts oscillating simple harmonically from its equilibrium position. Then ratio of kinetic energy and potential energy of particle at $\frac{T}{12}$ is

- (1) 2 : 1 (2) 3 : 1
(3) 1 : 1 (4) 1 : 4

42. 64 charged drops coalesce to form a bigger charged drop. The potential of bigger drop will be *n* times that of smaller drops then *n* is

- (1) 4 (2) 16
(3) 64 (4) 8

43. A wave is represented by $y = 0.4\sin\left(8t - \frac{x}{4}\right)$, where all the symbols have their usual meanings and are in SI units. The speed of the wave is

- (1) 32 m/s
(2) 64 m/s
(3) 20 m/s
(4) 15 m/s

44. Total energy of an electron in the hydrogen atom in the ground state is -13.6 eV. The potential energy of this electron is

- (1) 13.6 eV (2) 0
(3) -13.6 eV (4) -27.2 eV

45. If the resistance of a circuit having 12 V source is increased by 4 Ω, the current drops by 0.5 A. What is the original resistance of the circuit?

- (1) 4 Ω (2) 8 Ω
(3) 16 Ω (4) $\frac{1}{16}$ Ω

46. The electric potential at any point (*x*, *y*, *z*) in metres is given by $V = 3x^2$. The electric field at point (3, 0, 2) is

- (1) $-18 \frac{V}{m} \hat{i}$ (2) $18 \frac{V}{m} \hat{i}$
(3) $-12 \frac{V}{m} \hat{i}$ (4) $12 \frac{V}{m} \hat{i}$

47. In the circuit shown in the figure, the potential difference across the 4 μF capacitor is

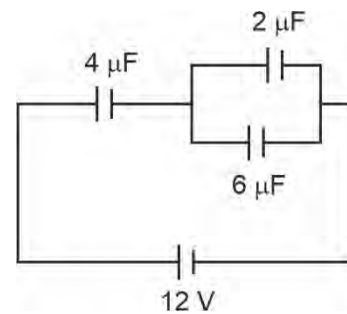

- (1) 4 V (2) 6 V
(3) 8 V (4) $\frac{8}{3}$ V

48. At a place the value of B_H and B_V are 0.4×10^{-4} T and 0.3×10^{-4} T respectively. The resultant earth's magnetic field is

- (1) 0.5×10^{-4} T (2) 10^{-4} T
(3) 2×10^{-4} T (4) 8×10^{-4} T

49. The ratio of the largest to shortest wavelengths in Balmer series of hydrogen spectra is

- (1) $\frac{25}{9}$ (2) $\frac{17}{6}$
 (3) $\frac{9}{5}$ (4) $\frac{5}{4}$

50. The junction diode shown in figure is ideal. The current in the circuit is

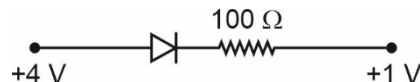

- (1) 50 A (2) 30 A
 (3) 50 mA (4) 30 mA

CHEMISTRY

SECTION - A

51. When NaCl crystal is heated in Na metal vapours, then it gives yellow appearance. It is due to

- (1) Schottky defect
 (2) Frenkel defect
 (3) Metal excess defect
 (4) Metal deficiency defect

52. An aqueous solution of a salt MX_2 at certain temperature has a van't Hoff factor of 2. The degree of dissociation (α) for this solution of the salt is

- (1) 0.33 (2) 0.50
 (3) 0.67 (4) 0.80

53. The oxidation state of Fe in brown ring complex, $[\text{Fe}(\text{H}_2\text{O})_5\text{NO}]\text{SO}_4$ is

- (1) +4 (2) +3
 (3) +1 (4) +2

54. The thermodynamic efficiency of a fuel cell is given as

- (1) $\frac{\Delta G}{\Delta S}$ (2) $\frac{\Delta S}{\Delta H}$
 (3) $\frac{\Delta G}{\Delta H}$ (4) $\frac{\Delta H}{\Delta G}$

55. Which of the properties of solution does not vary on dilution?

- (1) Normality
 (2) Molarity
 (3) Number of moles of solute
 (4) (w/v) %

56. Which among the following has the maximum number of molecules?

- (1) 4 g H_2 (2) 32 g O_2
 (3) 3 moles H_2O (4) 22.4 L CO_2 at STP

57. The correct order of increasing energies of atomic orbitals in a multi electronic system is

- (1) $4p < 3d < 4s < 3p$
 (2) $3p < 4s < 3d < 4p$
 (3) $3p < 3d < 4s < 4p$
 (4) $3d < 3p < 4s < 4p$

58. Which of the following set of quantum numbers does not exist?

- | n | l | m | s |
|-------|---|----|----------------|
| (1) 3 | 0 | 0 | $+\frac{1}{2}$ |
| (2) 2 | 1 | -1 | $-\frac{1}{2}$ |
| (3) 4 | 4 | -2 | $+\frac{1}{2}$ |
| (4) 3 | 2 | -2 | $-\frac{1}{2}$ |

59. For a first order reaction, the half life period is 10 minutes. The time required for the concentration of the substance to fall from $x\text{M}$ to $\frac{x}{16}\text{M}$ is

- (1) 25 minutes (2) 5 minutes
 (3) 40 minutes (4) 125 minutes

60. The number of bond pairs and lone pairs of electrons around bromine in BrF_5 respectively are

- (1) 1, 4 (2) 2, 3
 (3) 5, 1 (4) 3, 2

61. The bond order of O_2^- is

- (1) 2 (2) 2.5
 (3) 1.5 (4) 1

62. Equal masses of CH_4 and H_2 are mixed in a container at 25°C . Fraction of total pressure exerted by H_2 is

- (1) $\frac{2}{3}$ (2) $\frac{8}{9}$
 (3) $\frac{9}{8}$ (4) $\frac{3}{4}$

63. Average molar kinetic energies of O_2 and SO_2 at same temperature are related as (K_1 is the kinetic energy of O_2 and K_2 is the kinetic energy of SO_2 at same temperature)
- (1) $K_1 = 2K_2$ (2) $2K_1 = K_2$
 (3) $K_1 = \sqrt{K_2}$ (4) $K_1 = K_2$
64. Which of the following is a path function?
 (1) Work (2) Internal energy
 (3) Enthalpy (4) Entropy
65. The change in internal energy if 20 J of heat is released by the system at constant pressure and 10 J of work is done on the system, is
 (1) -30 J (2) -10 J
 (3) 10 J (4) 30 J
66. For a reaction $H_2(g) + I_2(g) \longrightarrow 2HI(g)$, $\Delta H = 37.5 \text{ kJ mol}^{-1}$ and $\Delta S = 150 \text{ JK}^{-1} \text{ mol}^{-1}$ the temperature at which the reaction will be at equilibrium is
 (1) 200 K (2) 250 K
 (3) 300 K (4) 350 K
67. For the reaction, $N_2(g) + 3H_2(g) \rightleftharpoons 2NH_3(g)$, If the value of equilibrium constant is K , then the equilibrium constant for the reaction, $NH_3(g) \rightleftharpoons \frac{1}{2}N_2(g) + \frac{3}{2}H_2(g)$ will be
 (1) \sqrt{K} (2) $\frac{1}{\sqrt{K}}$
 (3) $\frac{1}{K^2}$ (4) K^2
68. The conjugate base of HCO_3^- is
 (1) CO_2 (2) $C_2O_4^{2-}$
 (3) H_2CO_3 (4) CO_3^{2-}
69. The solubility of a salt A_2B in pure water will be (K_{sp} of $A_2B = 1.08 \times 10^{-16}$)
 (1) $3 \times 10^{-6} \text{ mol L}^{-1}$
 (2) $2 \times 10^{-8} \text{ mol L}^{-1}$
 (3) $4 \times 10^{-12} \text{ mol L}^{-1}$
 (4) $3 \times 10^{-18} \text{ mol L}^{-1}$
70. The oxidation state of Cr in CrO_5 is
 (1) +2 (2) +5
 (3) +6 (4) +3
71. Given the standard electrode potentials,
 $Al^{3+}/Al = -1.66 \text{ V}$ $Cu^{2+}/Cu = 0.34 \text{ V}$
 $K^+/K = -2.93 \text{ V}$ $Zn^{2+}/Zn = -0.76 \text{ V}$
 $Mg^{2+}/Mg = -2.36 \text{ V}$
 The correct order of these metals in their increasing order of reducing power is
 (1) $Zn < Cu < Mg < K < Al$
 (2) $K < Mg < Al < Zn < Cu$
 (3) $Cu < Zn < Mg < Al < K$
 (4) $Cu < Zn < Al < Mg < K$
72. **Assertion (A):** Aromatic 1° amines can be prepared by Gabriel phthalimide synthesis.
Reason (R): Aryl halides undergo nucleophilic substitution with anion formed by phthalimide.
 (1) Both assertion and reason are correct and reason is the correct explanation of assertion
 (2) Both assertion and reason are correct but reason is not the correct explanation of assertion
 (3) Assertion is correct but reason is incorrect
 (4) Both assertion and reason are incorrect
73. Which among the following has the highest hydration enthalpy?
 (1) Li^+
 (2) Na^+
 (3) K^+
 (4) Rb^+
74. Chemical formula of Plaster of Paris is
 (1) $NaHCO_3$ (2) $Na_2CO_3 \cdot 10H_2O$
 (3) $CaSO_4 \cdot 2H_2O$ (4) $CaSO_4 \cdot \frac{1}{2}H_2O$
75. The correct order of ionisation enthalpy of group-13 elements is
 (1) $Tl < In < Al < Ga < B$
 (2) $B < Al < Ga < In < Tl$
 (3) $Tl < In < Ga < Al < B$
 (4) $In < Al < Ga < Tl < B$
76. Acidic oxide among the following is
 (1) CO_2 (2) Al_2O_3
 (3) CO (4) Na_2O
77. The pOH of a solution at $25^\circ C$ that contains 10^{-2} M H^+ ion concentration is
 (1) 10 (2) 12
 (3) 4 (4) 2

78. The IUPAC name of the compound

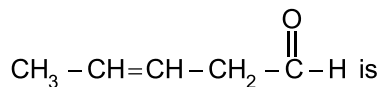

- (1) Pent-2-enal
 (2) Pent-3-enal
 (3) But-2-en-4-al
 (4) Pent-2-en-5-one

79. Among the following, aromatic species is

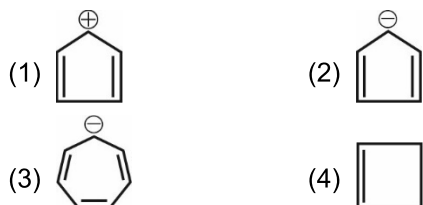

80. $\text{CH}_3 - \text{CH}_2 - \text{CHO}$ and $\text{CH}_3 - \text{CO} - \text{CH}_3$ are

- (1) Metamers
 (2) Position isomers
 (3) Chain isomers
 (4) Functional isomers

81. In the molecule, $\text{CH} \equiv \underset{1}{\text{C}} - \underset{2}{\text{C}} - \underset{3}{\text{CH}} = \underset{4}{\text{CH}} - \underset{5}{\text{CH}_3}$, the hybridisation of C_1 , C_3 and C_5 respectively are

- (1) sp , sp^3 , sp^2 (2) sp , sp^2 , sp^3
 (3) sp^3 , sp^2 , sp (4) sp^2 , sp , sp^3

82. During estimation of nitrogen present in an organic compound by Kjeldahl's method, the ammonia evolved from 1 g of the compound is neutralized by 20 mL of 0.5 M H_2SO_4 . The percentage of nitrogen in the compound is

- (1) 14%
 (2) 28%
 (3) 56%
 (4) 42%

83. In the reaction,

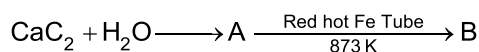

B is

- (1) $\text{CH}_2 = \text{CH}_2$

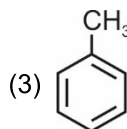
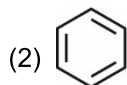

- (4) $\text{CH}_3 - \text{C} \equiv \text{CH}$

84. Match the given examples in column-I with their type of solution given in column-II.

	Column-I		Column-II
a.	Gold sol	(i)	Normal electrolyte solution
b.	Soap mixed with water above critical micelle concentration	(ii)	Multi molecular colloids
c.	Sol of starch	(iii)	Associated colloid
d.	Soap mixed with water below critical micelle concentration	(iv)	Macro molecular colloid

Select the correct option.

- (1) a(i), b(ii), c(iii), d(iv)
 (2) a(ii), b(iii), c(iv), d(i)
 (3) a(ii), b(iv), c(iii), d(i)
 (4) a(iv), b(ii), c(i), d(iii)

85. In Li_2O , having the antifluorite structure, the coordination numbers for O^{2-} ions and Li^+ ions respectively are

- (1) 4 and 4 (2) 4 and 8
 (3) 8 and 4 (4) 6 and 6

SECTION - B

86. A solution of urea has been prepared by dissolving 30 g of urea in 500 g of water. Freezing point of the solution will be (K_f for water = $1.86 \text{ K kg mol}^{-1}$)

- (1) 1.86°C (2) -1.86°C
 (3) -0.93°C (4) 0.93°C

87. The metal which is used in galvanising of iron is

- (1) Mg (2) Al
 (3) Zn (4) Ag

88. Which of the following is an example of homogeneous catalysis?

- (1) $\text{N}_2(\text{g}) + 3\text{H}_2(\text{g}) \xrightarrow{\text{Fe}(\text{s})} 2\text{NH}_3(\text{g})$
 (2) $4\text{NH}_3(\text{g}) + 5\text{O}_2(\text{g}) \xrightarrow{\text{Pt}(\text{s})} 4\text{NO}(\text{g}) + 6\text{H}_2\text{O}(\text{g})$
 (3) $2\text{SO}_2(\text{g}) + \text{O}_2(\text{g}) \xrightarrow{\text{NO}(\text{g})} 2\text{SO}_3(\text{g})$
 (4) Vegetable oils(l) + $\text{H}_2(\text{g}) \xrightarrow{\text{Ni}(\text{s})}$ Vegetable ghee (s)

89. Given below are two statements: one is labelled as assertion (A) and other is labelled as reason (R).

Assertion (A): Like bromination of benzene, bromination of phenol is also carried out in the presence of Lewis acid.

Reason (R): When phenol is treated with bromine water, para bromophenol is formed as major product.

In the light of the above statements, choose the most appropriate answer from the options given below:

- (1) Both assertion and reason are correct and reason is the correct explanation of assertion
 (2) Both assertion and reason are correct but reason is not the correct explanation of assertion
 (3) Assertion is correct but reason is incorrect
 (4) Both assertion and reason are incorrect
90. The product(s) obtained on reaction of Cu with dilute HNO_3 is/are

- (1) NO_2^- (2) NO
 (3) NO_2 (4) NO_2^+

91. Which of the following is coloured due to charge transfer?

- (1) $\text{Cr}_2\text{O}_7^{2-}$
 (2) $[\text{Ti}(\text{H}_2\text{O})_6]^{3+}$
 (3) $[\text{Cu}(\text{H}_2\text{O})_4]^{2+}$
 (4) $[\text{Zn}(\text{NH}_3)_4]^{2+}$

92. Which of the following is an ambidentate ligand?

- (1) en
 (2) Br^-
 (3) SCN^-
 (4) $\text{C}_2\text{O}_4^{2-}$

93. Which among the following is most reactive towards aromatic nucleophilic substitution?

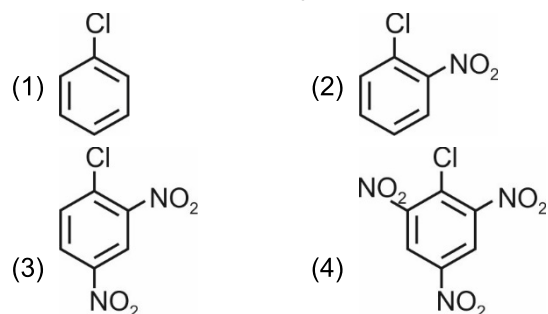

94. Butanal on reaction with ethyl magnesium bromide followed by hydrolysis gives

- (1) Aldehyde
 (2) Secondary alcohol
 (3) Tertiary alcohol
 (4) Carboxylic acid

95. The compound which will not give aldol condensation is

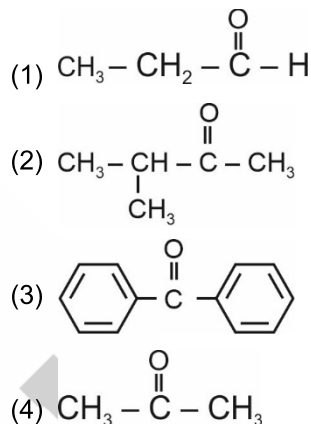

96. Consider the following reaction

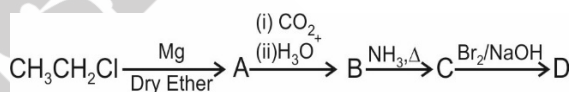

D is

- (1) $\text{CH}_3\text{CH}_2 - \text{NH} - \text{CH}_3$ (2) $\text{CH}_3\text{CH}_2 - \text{NH}_2$
 (3) $\text{CH}_3 - \overset{\text{O}}{\parallel}{\text{C}} - \text{NH}_2$ (4) $\text{CH}_3 - \overset{\text{O}}{\parallel}{\text{C}} - \text{OH}$

97. In the reaction,

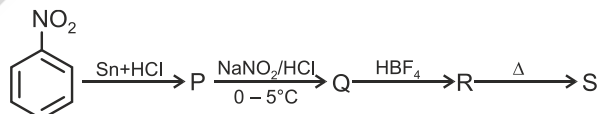

Identify S.

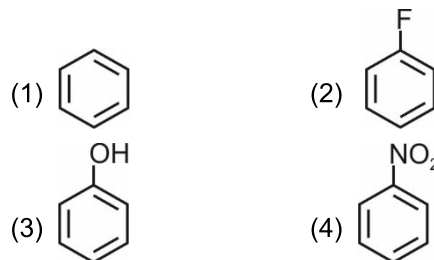

98. Maltose is composed of

- (1) α -D-glucose and β -D-fructose
 (2) α -D-glucose and α -D-glucose
 (3) β -D-galactose and β -D-glucose
 (4) α -D-glucose and β -D-galactose

99. Which of the following is a condensation polymer?
 (1) Terylene
 (2) Buna-N
 (3) Teflon
 (4) Polyacrylonitrile
100. The artificial sweetener with maximum sweetness value in comparison to cane sugar is
 (1) Aspartame
 (2) Saccharin
 (3) Sucralose
 (4) Alitame

BOTANY

SECTION - A

101. If a gamete in pollen tube has 12 pg of DNA then what amount of DNA would have been there in its pollen mother cell at G₂ phase?
 (1) 12 pg
 (2) 48 pg
 (3) 24 pg
 (4) 36 pg
102. In which of the following phases of karyokinesis, morphology of chromosomes is most easily studied?
 (1) Anaphase
 (2) Metaphase
 (3) Prophase
 (4) Telophase
103. Select the **incorrect** statement w.r.t. isobrachial chromosomes.
 (1) They are metacentric chromosomes
 (2) The centromere is present at the centre in these chromosomes
 (3) These chromosomes have two equal arms
 (4) They appear L – shaped during anaphase
104. Which of the following shows 9 + 0 arrangement of microtubules giving a cartwheel like appearance?
 (1) Centriole
 (2) Cilia
 (3) Flagella
 (4) Ribosome
105. Select the **incorrect** taxonomic category w.r.t. wheat.
 (1) Genus – *Triticum*
 (2) Order – Poales
 (3) Class – Dicotyledonae
 (4) Division – Angiospermae
106. Which of the following pair(s) is/are **incorrectly** matched?
 (i) *Amoeba* – Fission
 (ii) Filamentous algae – Fragmentation
 (iii) *Planaria* – Budding
 (iv) *Hydra* – True regeneration
 (1) Both (i) and (ii) (2) Both (i) and (iii)
 (3) Only (ii) (4) Both (iii) and (iv)
107. Match the following columns and select the **correct** option w.r.t. components of chloroplast.
- | | Column I | | Column II |
|----|-----------------|-------|-----------------------------------|
| a. | Thylakoids | (i) | Contains 70S ribosomes |
| b. | Stroma lamellae | (ii) | Flattened membranous sacs |
| c. | Stroma | (iii) | Stack of arranged sacs |
| d. | Granum | (iv) | Flat unstacked membranous tubules |
- (1) a(iv), b(ii), c(iii), d(i)
 (2) a(iv), b(ii), c(i), d(iii)
 (3) a(ii), b(iv), c(i), d(iii)
 (4) a(ii), b(iv), c(iii), d(i)
108. In monocotyledonous seed, the plumule and radicle are enclosed in sheath which are called _____ A _____ and _____ B _____ respectively.
 Choose the **correct** option for A and B.
 (1) A – Coleorhiza, B – Coleoptile
 (2) A – Coleoptile, B – Coleorhiza
 (3) A – Coleorhiza, B – Epiblast
 (4) A – Coleoptile, B – Pericarp

109. In which of the following, flowers show vexillary and twisted aestivation respectively?
- (1) Bean and china rose
 - (2) *Cassia* and pea
 - (3) Gulmohur and cotton
 - (4) Mustard and *Calotropis*
110. The dead component of phloem is
- (1) Phloem parenchyma
 - (2) Phloem fibre
 - (3) Sieve tube element
 - (4) Companion cell
111. Which of the following layers is absent in roots?
- (1) Hypodermis
 - (2) Pericycle
 - (3) Endodermis
 - (4) Epiblema
112. Which of the given organisms reproduce asexually by non-motile spores?
- (1) *Laminaria*
 - (2) *Polysiphonia*
 - (3) *Chara*
 - (4) *Volvox*
113. Mannitol is stored food material of
- (1) *Dictyota*
 - (2) *Polysiphonia*
 - (3) *Eudorina*
 - (4) *Ulothrix*
114. The causal agents of 'mad cow' disease
- (1) Contain DNA as genetic material
 - (2) Are abnormally folded proteins
 - (3) Are larger than viruses
 - (4) Do not cause any disease in humans
115. Which of the following statements is **correct** w.r.t. fungi?
- (1) They prefer to grow in cold and dry places
 - (2) They have no cell wall
 - (3) *Penicillium* is commercially used in baking
 - (4) Morels and truffles are edible
116. What is the genetic disorder in which female has chromosome complement 44 + XO and such females are sterile with short stature, rudimentary ovaries and no menstrual cycle?
- (1) Klinefelter's syndrome
 - (2) Down's syndrome
 - (3) Turner's syndrome
 - (4) Edward syndrome
117. Mark the following statements as **true (T)** or **false (F)** and select the **correct** option.
- A. Simple diffusion is carried out by special membrane proteins.
 - B. Facilitated diffusion is selective in nature.
 - C. Facilitated diffusion is ATP dependent.
 - D. Active transport uses energy to transport molecules against concentration gradient.
- | | A | B | C | D |
|-----|---|---|---|---|
| (1) | T | T | T | T |
| (2) | F | T | F | T |
| (3) | T | F | T | T |
| (4) | F | T | T | F |
118. *Nitrosomonas* and *Nitrobacter* are autotrophs but they do not use solar energy for synthesis of food because
- (1) They do not fix CO₂
 - (2) They can fix N₂ along with CO₂
 - (3) They use chemical energy liberated during oxidation of inorganic substances
 - (4) They have chlorophyll but they can fulfill their food requirements from other organisms
119. Cyclic photophosphorylation differs from non-cyclic photophosphorylation as latter involves
- (a) Splitting of H₂O
 - (b) Formation of NADPH + H⁺
 - (c) Formation of ATP
 - (d) Requirement of external electron source
- (1) Only (a) and (b)
 - (2) Only (a), (b) and (d)
 - (3) Only (b) and (c)
 - (4) Only (c)
120. Select the **incorrect** statement w.r.t. glycolysis.
- (1) Glycolysis takes place in cytoplasm
 - (2) It occurs both in aerobes and anaerobes
 - (3) There is no use of energy in the whole process
 - (4) Pyruvic acid is the end product of it
121. Mark the **odd** one out w.r.t. functions of auxins.
- (1) It promotes the abscission of older mature leaves, fruits and flowers
 - (2) It promotes cell division
 - (3) It controls xylem differentiation
 - (4) It induces bolting in rosette habit plants

122. The progenitor of the next generation in mature seed is
 (1) Endosperm (2) Gamete
 (3) Spore (4) Embryo
123. Which layer of anther wall is ephemeral in nature?
 (1) Epidermis (2) Endothecium
 (3) Middle layer (4) Tapetum
124. Select the **incorrect** match.
 (1) ZW – ZZ type – Birds
 (2) XX – XO type – *Drosophila*
 (3) ZO – ZZ type – Butterflies
 (4) XX – XY type – Human
125. Flower colour in *Antirrhinum majus* is an example of
 (1) Pleiotropism
 (2) Multiple allelism
 (3) Co-dominance
 (4) Incomplete dominance
126. A haemophilic and colour blind male marries a homozygous normal female. What is the percentage of their son to become haemophilic but not colour blind?
 (1) 0% (2) 50%
 (3) 75% (4) 25%
127. Select the **incorrect** statement w.r.t. VNTRs.
 (1) They show very high degree of polymorphism
 (2) They are surrounded by conserved restriction sites
 (3) They are microsatellites
 (4) Their size vary from 0.1 to 20 kb
128. During transcription, the dsDNA helix is unwinded by the enzyme
 (1) Helicase (2) DNA gyrase
 (3) RNA polymerase (4) DNA polymerase
129. In the given flow chart of central dogma, select the **correct** option w.r.t. enzymes involved in the steps.
- (a)
$$\text{DNA} \xrightarrow[\text{(b)}]{\text{Transcription}} \text{mRNA} \xrightarrow[\text{Translation}]{\text{(c)}} \text{Proteins}$$
- (1) (a) DNA polymerase
 (b) RNA polymerase
 (c) Peptidyl transferase
- (2) (a) RNA polymerase
 (b) Reverse transcriptase
 (c) DNA polymerase
- (3) (a) DNA dependent DNA polymerase
 (b) RNA dependent DNA polymerase
 (c) Peptidyl transferase
- (4) (a) RNA dependent RNA polymerase
 (b) Transcriptase
 (c) DNA polymerase
130. The productivity of oceans is $\frac{A}{B}$ billion tons and for terrestrial ecosystem is $\frac{B}{A}$ billion tons.
 Choose the **correct** option for A and B.
 (1) A – 155, B – 115 (2) A – 15, B – 55
 (3) A – 55, B – 115 (4) A – 55, B – 15
131. Number of individuals of different age group in the urn-shaped age pyramid for human population will be
 (1) Pre-reproductive > Reproductive > Post-reproductive
 (2) Pre-reproductive = Reproductive > Post-reproductive
 (3) Pre-reproductive < Reproductive > Post-reproductive
 (4) Pre-reproductive \geq Reproductive = Post-reproductive
132. In how many of the following areas primary succession takes place?
 (a) Newly created ponds
 (b) Igneous rocks
 (c) Abandoned farmlands
 (d) Burnt forest
 (e) Flooded lands
 (f) Sand dunes
 (1) Five (2) Four
 (3) Three (4) Six
133. Which of the given bacteria play very beneficial role in checking disease causing microbes in our stomach?
 (1) Lactic acid bacteria (LAB)
 (2) *Methanococcus*
 (3) *Streptococcus*
 (4) *Propionibacterium sharmanii*

134. Select the **incorrect** statement w.r.t. organism called 'Terror of Bengal'.
- (1) It is alien species introduced in India
 - (2) It propagates vegetatively at a phenomenal rate
 - (3) Grows abundantly in eutrophic water bodies
 - (4) Maintains ecosystem dynamics of water body
135. Montreal Protocol aimed at
- (1) Controlling emission of ozone depleting substances
 - (2) Protection of forests
 - (3) Sustainable use of resources
 - (4) Controlling biodiversity loss

SECTION - B

136. Which of the following is **incorrect** w.r.t. imperfect fungi?
- (1) Their mycelium is septate and branched
 - (2) They reproduce asexually by conidia formation
 - (3) They do not form fruiting bodies
 - (4) They lack sex organs but perform sexual reproduction
137. **Statement A:** It is not seen in phloem of monocots.
Statement B: It stores food materials and other substances like resins, latex and mucilage.
On the basis of above statements, identify the **correct** component of phloem.
- (1) Sieve tube
 - (2) Phloem parenchyma
 - (3) Companion cell
 - (4) Phloem fibre
138. Which of the following plants shows opposite phyllotaxy?
- (1) Sunflower
 - (2) China rose
 - (3) Guava
 - (4) *Alstonia*
139. One of the commercial products obtained from *Gelidium* and *Gracilaria* is
- (1) Agar
 - (2) Algin
 - (3) Mannitol
 - (4) Laminarin

140. The process of absorption of water by hydrophilic solid particles of a substance without forming solution is called
- (1) Plasmolysis
 - (2) Reverse osmosis
 - (3) Imbibition
 - (4) Guttation
141. The only gaseous phytohormone
- (1) Induces dormancy of seeds
 - (2) Increases the number of male flowers in cucumber
 - (3) Promotes root growth and root hair formation
 - (4) Prevents abscission
142. 70S type of ribosomes are not seen in
- (1) Bacterial cells
 - (2) Mitochondria
 - (3) Cytoplasm of eukaryotic cells
 - (4) Chloroplast
143. The given below figure is a typical dicot embryo. What do A, B and C represent respectively?

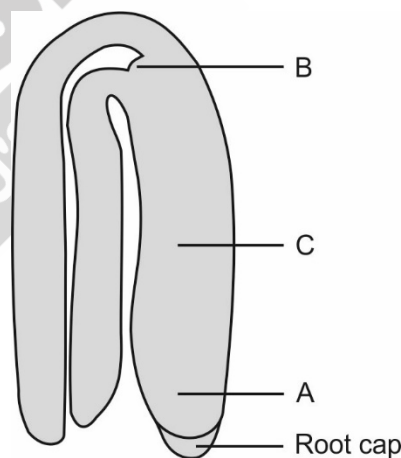

- | A | B | C |
|---------------|-----------|-----------|
| (1) Radicle | Plumule | Cotyledon |
| (2) Hypocotyl | Cotyledon | Plumule |
| (3) Radicle | Plumule | Hypocotyl |
| (4) Plumule | Radicle | Cotyledon |

144. Which of the given is acellular and causes bovine spongiform encephalopathy (BSE) in cattles?
- (1) Bacteriophage
 - (2) Prions
 - (3) Viroid
 - (4) TMV

145. Alcoholic beverages produced without distillation are
 (1) Wine and beer (2) Wine and whisky
 (3) Whisky and rum (4) Brandy and rum
146. Read the following statements and select the **correct** option.
Statement I: The codon 'GUG' codes for valine and also terminates the translation process.
Statement II: The codon 'AUG' codes for methionine and also initiates the translation process.
 (1) Only statement I is true
 (2) Only statement II is true
 (3) Both the statements are true
 (4) Both the statements are false
147. Organisms that live in areas where the temperature is uniform throughout the year are
 (1) Euryhaline (2) Stenohaline
 (3) Eurythermal (4) Stenothermal
148. Which of the following is functional and structural aspects of ecosystem respectively?
 (1) Productivity and stratification
 (2) Species composition and energy flow
 (3) Stratification and decomposition
 (4) Nutrient cycling and energy flow
149. Most important cause of biodiversity loss is
 (1) Over exploitation
 (2) Co-extinction
 (3) Habitat loss and fragmentation
 (4) Alien species invasion
150. El Nino effect is related with
 (1) Global warming
 (2) Ozone depletion
 (3) Water pollution
 (4) Noise pollution

ZOOLOGY

SECTION - A

151. Which of the following hormones is mainly responsible for ovulation and stimulates corpus luteum in menstrual cycle?
 (1) FSH
 (2) Estrogen
 (3) LH
 (4) Progesterone
152. Match the column I and column II.
- | | Column I | | Column II |
|----|--------------------|-------|--|
| a. | Muscular dystrophy | (i) | Wild contractions in muscles due to low Ca^{2+} in body fluid |
| b. | Myasthenia gravis | (ii) | Caused due to accumulation of uric acid crystals |
| c. | Gout | (iii) | Degeneration of skeletal muscles |
| d. | Tetany | (iv) | Affecting neuromuscular junctions and finally leads to paralysis of skeletal muscles |
- Choose the **correct** option.
 (1) a(i), b(ii), c(iii), d(iv)
 (2) a(iii), b(iv), c(ii), d(i)
 (3) a(ii), b(iii), c(iv), d(i)
 (4) a(iv), b(i), c(iii), d(ii)
153. The levels of various hormones during pregnancy rises many folds.
 Which of the following reasons does not support this statement?
 (1) They are essential for maintaining the pregnancy.
 (2) They support foetal growth.
 (3) They are essential for formation of secondary follicles.
 (4) They are necessary for supporting metabolic changes in mother.
154. When readymade antibodies are directly injected to protect the body against foreign agents, it is called
 (1) Artificial passive immunity
 (2) Natural passive immunity
 (3) Artificial active immunity
 (4) Natural active immunity

155. Choose the **incorrect** statement w.r.t. an electrical synapse.
- (1) The membrane of pre and post synaptic neurons are in very close proximity.
 - (2) Electrical current cannot flow directly from one neuron to another neuron.
 - (3) Impulse conduction in an electrical synapse is always faster than chemical synapse.
 - (4) They are rare in the human system.
156. The right and left cerebral hemispheres are connected by a tract of nerve fibers called
- (1) Corpus luteum
 - (2) Corpora quadrigemina
 - (3) Corpus callosum
 - (4) Cerebral aqueduct
157. Tendons attach A and is an example of B connective tissue. Choose the option that fills the blanks **correctly**.

	A	B
(1)	Muscles to bone	Dense regular
(2)	Bone to bone	Dense regular
(3)	Muscles to bone	Dense irregular
(4)	Muscle to muscle	Dense regular

158. Read the following statements.
- a. Glucose is partially absorbed in the PCT.
 - b. ADH helps in diluting the urine by acting on DCT and collecting ducts.
 - c. In cortical nephrons, vasa recta is absent or highly reduced.
 - d. In a healthy person, 180 litre glomerular filtrate is formed per day by the kidneys.
- Which of the above statements are **correct**?
- (1) c and d
 - (2) a and b
 - (3) a and c
 - (4) b and d
159. Which of the following has a restriction site in the same antibiotic resistance gene as *PvuI* in pBR322?
- (1) *Bam* HI
 - (2) *Sal* I
 - (3) *Pst* I
 - (4) *Pvu* II

160. When the doctor taps the patella with a rubber headed hammer, simple knee jerk reflex occurs. Which of the following is not involved in this reflex?
- (1) Quadriceps muscle
 - (2) Motor neuron
 - (3) Interneuron
 - (4) Muscle spindle
161. Choose the **incorrect** match w.r.t category of biomolecules and their examples.
- (1) Nucleoside : Adenosine
 - (2) Nucleotide : Uridylic acid
 - (3) Nucleic acid : Proteins
 - (4) Phospholipid : Lecithin
162. Transfer of ovum collected from a donor into the fallopian tube of another woman who cannot produce one, but can provide suitable environment for fertilization and further development, is done in case of
- (1) GIFT
 - (2) ICSI
 - (3) AI
 - (4) IUI
163. Volume of air that remains in lungs after a normal expiration is termed as
- (1) Residual volume
 - (2) Tidal volume
 - (3) Functional residual capacity
 - (4) Expiratory capacity
164. Atrial natriuretic factor is secreted in response to
- (1) Increased blood pressure
 - (2) Decreased blood pressure
 - (3) Decreased respiration rate
 - (4) Decreased heart rate
165. Blood concentration of glucose in a normal healthy individual is
- (1) 2.2 – 4.2 mmol/L
 - (2) 242 – 420 mmol/L
 - (3) 0.24 - 0.61 mmol/L
 - (4) 4.2 - 6.1 mmol/L
166. The members of class Chondrichthyes mainly have
- (1) Separated gill slits without operculum
 - (2) External fertilization
 - (3) Monoecious condition
 - (4) Air bladder for buoyancy

167. *B. thuringiensis* forms protein crystals during a particular growth phase. These crystals contain a toxic protein which is
- (1) Herbicidal (2) Insecticidal
(3) Bactericidal (4) Fungicidal
168. Succinate dehydrogenase is inhibited by _____ which closely resembles the substrate succinate. Fill in the blank with the correct option.
- (1) Citrate
(2) Acetate
(3) Malonate
(4) Lactic acid
169. Identify the **incorrect** match.
- (1) Emerging from glomerulus – Afferent arteriole
(2) Cortical nephrons – Comparatively more in number than juxtamedullary nephrons
(3) Blood filtered by kidneys – 1200 mL/min
(4) Coiled region of nephron – PCT and DCT
170. In a population of 1000 individuals, 490 are dominant homozygous with genotype AA. Based on this data, the frequency of allele 'a' in the population and number of heterozygotes respectively are
- (1) 0.3, 420 (2) 0.7, 490
(3) 0.21, 420 (4) 0.3, 90
171. The end of luteal phase is marked by the decline in concentration of
- (1) Oxytocin (2) hPL
(3) Progesterone (4) Prolactin
172. The X continues to divide and transforms into blastocyst as it moves further into the uterus. Identify 'X' and select the correct option.
- (1) Trophoblast (2) Gastrula
(3) Ootid (4) Morula
173. In 1963, two enzymes were isolated from *E. coli*. Which statement is **correct** regarding these enzymes?
- (1) These two enzymes were oxidoreductases.
(2) These two enzymes were a transferase and a polymerase.
(3) One of them added methyl groups to DNA, while the other cut DNA.
(4) One of them was a ligase and the other cut DNA.
174. Excretory product of *Periplaneta*, is
- (1) Urea (2) Ammonia
(3) Uric acid (4) Guanine
175. In human body, the number of carpals in each upper limb is equivalent to number of
- (1) Cranial bones (2) Facial bones
(3) Intervertebral discs (4) Cervical vertebrae
176. The toxin coded by *cryIAc* is an inactive protein known as
- (1) α -1-antitrypsin
(2) Interferon
(3) Protoxin
(4) Alpha lactalbumin
177. The least number of WBCs in the blood are
- (1) Neutrophils (2) Eosinophils
(3) Basophils (4) Lymphocytes
178. pO_2 in systemic artery and pulmonary vein is respectively
- (1) 40 mm Hg, 40 mm Hg
(2) 95 mm Hg, 95 mm Hg
(3) 45 mm Hg, 95 mm Hg
(4) 95 mm Hg, 40 mm Hg
179. How many of the following structures constitute the female accessory ducts?
- | |
|--|
| Fallopian tube, Vagina, Uterus, Ovary, Mons pubis, Uvula, Clitoris |
|--|
- Choose the **correct** option.
- (1) 7 (2) 5
(3) 2 (4) 3
180. What is **true** regarding menstrual cycle?
- (1) Follicular phase is followed by menstrual phase.
(2) Lack of menstruation may be an indicative sign of pregnancy.
(3) Menstrual cycle is absent in monkeys.
(4) Progesterone surge induces ovulation.
181. Molecular diagnostic technique based on antigen antibody interaction is
- (1) PCR
(2) Gel electrophoresis
(3) ELISA
(4) Autoradiography

182. Enzymes catalyse biochemical reactions by
- (1) Lowering activation energy
 - (2) Increasing activation energy
 - (3) Establishing stable bonds with substrate
 - (4) Increasing temperature
183. Different characters observed in spotted cuscus, bandicoot, wombat and koala are the examples of
- (1) Divergent evolution
 - (2) Convergent evolution
 - (3) Co-evolution
 - (4) Artificial selection
184. Identify the hormone with its correct source gland and mechanism of action.

	Hormone	Source gland	Mode of action
(1)	Oxytocin	Pars nervosa	Contraction in myometrium of uterus
(2)	PTH	Parathyroid	Hypocalcemic hormone
(3)	TCT	Thyroid	Calcium metabolism
(4)	Thymosin	Pineal gland	Differentiation of T-lymphocytes

185. The mechanism through which single step large mutation leads to evolution was proposed by
- (1) Mendel
 - (2) Darwin
 - (3) DeVries
 - (4) Lamarck

SECTION - B

186. Which of the following methods is necessary if we want to evolve a pure line in any animal?
- (1) Out-breeding
 - (2) Interspecific hybridisation
 - (3) Inbreeding
 - (4) Saltation
187. Organic co-factors which are tightly bound to the apoenzymes are called
- (1) Inhibitors
 - (2) Hormones
 - (3) Prosthetic groups
 - (4) Metal ions

188. Select the **incorrect** statement w.r.t. blood vessels.
- (1) Arteries have no valves.
 - (2) Veins are collapsible because they have thin walls.
 - (3) Tunica interna of arteries is mainly responsible for vasoconstriction.
 - (4) The tunica media is comparatively thin in the veins.
189. Choose the **false** statement about *Amphioxus*.
- (1) It is exclusively a marine animal.
 - (2) It belongs to Cephalochordata.
 - (3) Notochord extends from head to tail.
 - (4) Notochord is present only in the larval stage.
190. The mitotic division starts as the 'A' moves through the isthmus of the oviduct towards the uterus and is called 'B'.

What does 'A' and 'B' represent in the given columns?

	A	B
(1)	Cleavage	Zygote
(2)	Zygote	Cleavage
(3)	Implantation	Blastocyst
(4)	Follicle	Morula

191. Acute chest pain appears when enough oxygen is not reaching the heart muscle. This is the main symptom of
- (1) Angina Pectoris
 - (2) Myocardial infarction
 - (3) Heart block
 - (4) Heart failure
192. Which of the following suppresses sperm motility by releasing copper ions?
- (1) Multiload 375
 - (2) LNG-20
 - (3) Lippes loop
 - (4) Vaults
193. GIFT technique cannot be used for
- (1) *In vivo* fertilization
 - (2) Female who can provide suitable environment for implantation
 - (3) Test tube baby programme
 - (4) A female who cannot produce ova

194. The right end is called the reducing end and left end is called the non-reducing end. The above statement stands true for
- (1) Monosaccharides
 - (2) Nitrogenous bases
 - (3) Polysaccharides
 - (4) Triglycerides
195. Arrange the following digestive juices in order of decreasing pH and select the correct option.
- (A) Pancreatic juice
 - (B) Saliva
 - (C) Gastric juice
- (1) (A), (B), (C) (2) (C), (A), (B)
 - (3) (B), (A), (C) (4) (C), (B), (A)
196. Choose the **odd** one w.r.t. Urochordates.
- (1) *Ascidia* (2) *Salpa*
 - (3) *Branchiostoma* (4) *Doliolum*
197. Which of the following group of animals are bilaterally symmetrical and show presence of pseudocoelom?
- (1) *Nereis*, *Pheretima*, *Hirudinaria*
 - (2) *Ascaris*, *Wuchereria*, *Ancylostoma*
 - (3) *Pila*, *Octopus*, *Pinctada*
 - (4) *Asterias*, *Echinus*, *Ophiura*

198. The diagrammatic representation given below is the sectional view of an adrenal gland

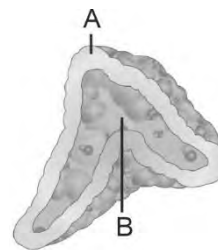

Choose the **correct** option.

- (1) A represents the adrenal medulla.
 - (2) B secretes catecholamines.
 - (3) Secretion of part A decreases the glucose level.
 - (4) Secretion of part B decreases alertness and constricts the pupil.
199. The central part of thick filament, not overlapped by thin filaments is called
- (1) Sarcomere (2) Z-line
 - (3) H-zone (4) I band
200. Calculate the total duration between dub and lub heart sounds during normal cardiac cycle.
- (1) 0.7 s (2) 0.5 s
 - (3) 0.1 s (4) 0.8 s



**Scan the QR Code for
Detailed Video Solutions**

(*Video will be available to access post 8 p.m. 21st April, 2023 onwards)



FINAL TEST SERIES for NEET-2023

MM : 720

Test-10

Time : 3 Hrs. 20 Mins.

Answers

1. (4)	41. (2)	81. (2)	121. (4)	161. (3)
2. (2)	42. (2)	82. (2)	122. (4)	162. (1)
3. (1)	43. (1)	83. (2)	123. (3)	163. (3)
4. (1)	44. (4)	84. (2)	124. (2)	164. (1)
5. (2)	45. (2)	85. (3)	125. (4)	165. (4)
6. (3)	46. (1)	86. (2)	126. (1)	166. (1)
7. (3)	47. (3)	87. (3)	127. (3)	167. (2)
8. (2)	48. (1)	88. (3)	128. (3)	168. (3)
9. (3)	49. (3)	89. (4)	129. (1)	169. (1)
10. (1)	50. (4)	90. (2)	130. (3)	170. (1)
11. (3)	51. (3)	91. (1)	131. (3)	171. (3)
12. (1)	52. (2)	92. (3)	132. (3)	172. (4)
13. (1)	53. (3)	93. (4)	133. (1)	173. (3)
14. (4)	54. (3)	94. (2)	134. (4)	174. (3)
15. (4)	55. (3)	95. (3)	135. (1)	175. (1)
16. (1)	56. (3)	96. (2)	136. (4)	176. (3)
17. (4)	57. (2)	97. (2)	137. (2)	177. (3)
18. (2)	58. (3)	98. (2)	138. (3)	178. (2)
19. (3)	59. (3)	99. (1)	139. (1)	179. (4)
20. (1)	60. (3)	100. (4)	140. (3)	180. (2)
21. (4)	61. (3)	101. (2)	141. (3)	181. (3)
22. (4)	62. (2)	102. (2)	142. (3)	182. (1)
23. (1)	63. (4)	103. (4)	143. (3)	183. (1)
24. (1)	64. (1)	104. (1)	144. (2)	184. (3)
25. (1)	65. (2)	105. (3)	145. (1)	185. (3)
26. (1)	66. (2)	106. (4)	146. (2)	186. (3)
27. (2)	67. (2)	107. (3)	147. (4)	187. (3)
28. (3)	68. (4)	108. (2)	148. (1)	188. (3)
29. (2)	69. (1)	109. (1)	149. (3)	189. (4)
30. (1)	70. (3)	110. (2)	150. (1)	190. (2)
31. (4)	71. (4)	111. (1)	151. (3)	191. (1)
32. (1)	72. (4)	112. (2)	152. (2)	192. (1)
33. (4)	73. (1)	113. (1)	153. (3)	193. (3)
34. (3)	74. (4)	114. (2)	154. (1)	194. (3)
35. (1)	75. (4)	115. (4)	155. (2)	195. (1)
36. (4)	76. (1)	116. (3)	156. (3)	196. (3)
37. (1)	77. (2)	117. (2)	157. (1)	197. (2)
38. (4)	78. (2)	118. (3)	158. (1)	198. (2)
39. (2)	79. (2)	119. (2)	159. (3)	199. (3)
40. (3)	80. (4)	120. (3)	160. (3)	200. (2)

FINAL TEST SERIES for NEET-2023

MM : 720

Test-10

Time : 3 Hrs. 20 Mins.

Answers and Solutions**PHYSICS****SECTION - A**

1. Answer (4)

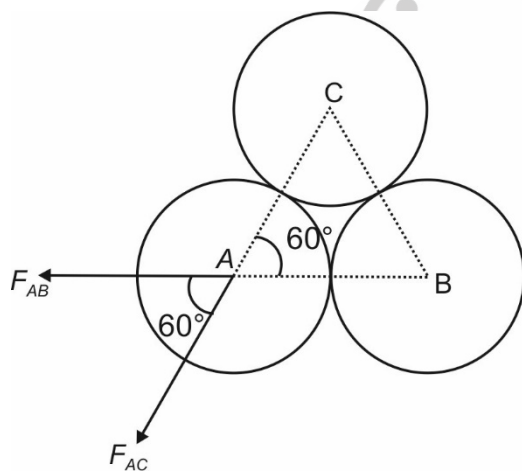

$$F_{AB} = \frac{1}{4\pi\epsilon_0} \frac{q^2}{4R^2};$$

$$F_{AC} = \frac{1}{4\pi\epsilon_0} \frac{q^2}{4R^2}$$

$$F_A = \sqrt{F^2 + F^2 + 2F^2 \cos(60^\circ)}$$

$$= \sqrt{3} F$$

$$\Rightarrow F_A = \sqrt{3} \left(\frac{1}{4\pi\epsilon_0} \right) \frac{q^2}{4R^2}$$

Substituting the given values,

$$F_A = 3.9 \times 10^{-3} \text{ N}$$

2. Answer (2)

$$T = m\omega^2 R$$

$$\omega = \sqrt{\frac{T}{mR}}$$

$$\omega = \sqrt{\frac{4}{4 \times 169}} = \frac{1}{13} \text{ rad/s}$$

$$v = \omega R = \frac{169}{13} = 13 \text{ m/s}$$

3. Answer (1)

$$W_{\text{all}} = \Delta \text{KE} = 0$$

$$mg \sin(\alpha) \left(\frac{ml}{m+n} + \frac{nl}{m+n} \right)$$

$$= \mu mg \cos \alpha \left(\frac{nl}{m+n} \right)$$

$$\Rightarrow \mu = \tan \alpha \left(\frac{m+n}{n} \right)$$

4. Answer (1)

Using conservation of mechanical energy,

$$\frac{1}{2} \mu v_{\text{rel}}^2 = \frac{1}{2} kx^2$$

$$x = \sqrt{\frac{\mu}{k}} v_{\text{rel}}$$

$$= \sqrt{\frac{(2 \times 4)}{(2+4) \times 200}} \times 10 = \frac{2}{\sqrt{6}} \text{ m}$$

5. Answer (2)

$$M = \frac{\phi}{i}$$

$$M = \int_a^{2a} \frac{\mu_0}{2\pi x} a dx = \frac{\mu_0 a}{2\pi} \ln(2)$$

6. Answer (3)

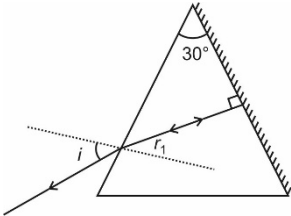

$$r_2 = 0$$

$$\Rightarrow r_1 + r_2 = 30^\circ$$

$$r_1 = 30^\circ$$

$$1 \times \sin 45^\circ = \mu \sin(30^\circ)$$

$$\mu = \sqrt{2}$$

7. Answer (3)

$$F = \frac{Kq_1(Q - q_1)}{r^2}$$

Now, for F to be max

$$\frac{dF}{dq_1} = 0$$

$$\Rightarrow q_1 = \frac{Q}{2}$$

$$\text{and } q_2 = \frac{Q}{2}$$

8. Answer (2)

The magnitudes are Pythagoras triplets.

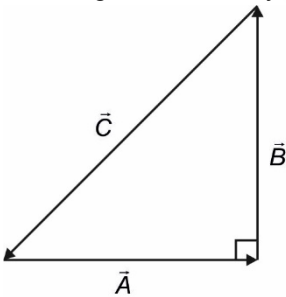

9. Answer (3)

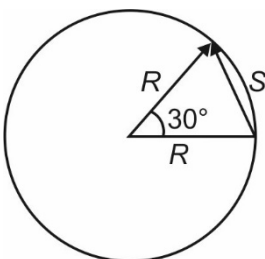

$$S = \sqrt{R^2 + R^2 - 2R^2 \cos 30^\circ}$$

$$= R\sqrt{2}(\sqrt{1 - \cos 30^\circ})$$

$$= 2R \sin 15^\circ$$

10. Answer (1)

$$100 \times 0.5 \times 20 + 100 \times 80 + 100 \times 40 = x \times 40$$

$$\Rightarrow x = 325 \text{ g}$$

11. Answer (3)

For nuclei of middle mass number ($30 < A < 170$) the binding energy per nucleon is almost constant and it is lower for both light nuclei ($A < 30$) and heavy nuclei ($A > 170$).

12. Answer (1)

$$b \sin(\theta) = \pm \lambda$$

(max divergence occurs between two first order minima)

$$\sin(\theta) = \pm \frac{\lambda}{b}$$

$$= \pm \frac{600 \times 10^{-9}}{0.4 \times 10^{-3}} = \pm 1.5 \times 10^{-3}$$

$$\text{Angular divergence} = 3 \times 10^{-3} \text{ rad}$$

13. Answer (1)

$$E = E_0 \sin(kx - \omega t)$$

$$E_{\text{avg}} = 0$$

14. Answer (4)

$$\text{Area} = \pi \left(\frac{30-10}{2} \right) \left(\frac{30-10}{2} \right) \times 10^3 \times 10^{-3}$$

$$= \pi \times 10 \times 10$$

$$= 100 \pi \text{ J}$$

15. Answer (4)

$$l_1 - l_0 = \frac{T_1 \cdot l_0}{AY} \quad \dots(1)$$

$$l_2 - l_0 = \frac{T_2 \cdot l_0}{AY} \quad \dots(2)$$

$$(1) / (2)$$

$$\Rightarrow (l_1 - l) T_2 = T_1 (l_2 - l)$$

$$\frac{T_2 l_1 - l_2 T_1}{T_2 - T_1} = l$$

16. Answer (1)

$$S = \frac{1}{2} g t^2 = \frac{1}{2} \times 10 \times 16 = 80 \text{ m}$$

$$(v_{\text{avg}}) = \frac{S}{t} = \frac{80}{4} = 20 \text{ m/s}$$

17. Answer (4)

As per symmetry $l_1 = l_2 = l_3$

\Rightarrow Ratio = 2 : 1

18. Answer (2)

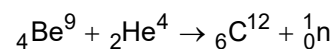

19. Answer (3)

$$\frac{n}{t} \left(\frac{hc}{\lambda} \right) = P$$

$$\frac{n}{t} = \frac{P \times \lambda}{hc}$$

$$= \frac{60 \times 6600}{12400 \times 1.6} \times 10^{19}$$

$$= 2 \times 10^{20} \text{ photon per second}$$

20. Answer (1)

$$A + \bar{B} = 1 + 1$$

$$= 1$$

$$= A$$

21. Answer (4)

$$n = \tan i_B$$

$$\Rightarrow i_B = \tan^{-1}(n)$$

22. Answer (4)

$$\frac{1}{f} = (\mu - 1) \left(\frac{1}{R_1} - \frac{1}{R_2} \right)$$

$$\frac{f_v}{f_r} = \left(\frac{\mu_r - 1}{\mu_v - 1} \right)$$

$$\frac{f_v}{f_r} = \frac{0.50}{0.55}$$

$$\frac{f_v}{f_r} = \frac{10}{11}$$

$$f_r = 22 \text{ cm}$$

23. Answer (1)

$$\frac{1}{v} + \frac{1}{u} = \frac{1}{f}$$

$$\frac{1}{v} - \frac{1}{8} = -\frac{1}{10}$$

$$\frac{1}{v} = -\frac{1}{10} + \frac{1}{8}$$

$$\frac{1}{v} = \frac{-4 + 5}{40}$$

$$v = +40 \text{ cm virtual}$$

24. Answer (1)

$$PV = nRT$$

In an adiabatic expansion, internal energy decreases hence temperature decreases.

25. Answer (1)

$$\frac{1}{2}(n_1 + n_2)fRT = \frac{1}{2}n_1f_1RT + \frac{1}{2}n_2f_2RT$$

$$\left(4 + \frac{1}{2} \right) f = 4 \times 3 + \frac{1}{2} \times 5$$

$$\frac{9}{2}f = 12 + \frac{5}{2}$$

$$\frac{9f}{2} = \frac{29}{2}$$

$$f = \left(\frac{29}{9} \right)$$

$$\gamma = \frac{f + 2}{f}$$

$$= \frac{\frac{29}{9} + 2}{\frac{29}{9}}$$

$$= \frac{29 + 18}{29}$$

$$= \frac{47}{29}$$

$$= 1.62$$

26. Answer (1)

$$\frac{1}{2l} \sqrt{\frac{T}{\mu}} = \frac{v}{4l} \quad \dots(i)$$

$$\frac{1}{2l} \sqrt{\frac{T+8}{\mu}} = \frac{3v}{4l} \quad \dots(ii)$$

(i) \div (ii)

$$\sqrt{\frac{T}{T+8}} = \frac{1}{3} \Rightarrow T = 1 \text{ N}$$

27. Answer (2)

$$P = \frac{v^2 dm}{dt}$$

$$P = (4)^2 \times 5$$

$$= 80 \text{ W}$$

28. Answer (3)

$$\vec{r}_{c.m} = \frac{\vec{r}_1 m_1 - \vec{r}_2 m_2 + \vec{r}_3 m_3 + \vec{r}_4 m_4}{m_1 + m_2 + m_3 + m_4}$$

$$= \frac{1 \times 2 + 1.5 \times 1 + 2 \times 2 + M(-1)}{M + 4.5} = 1$$

$$\Rightarrow M = \frac{3}{2} = 1.5 \text{ kg}$$

29. Answer (2)

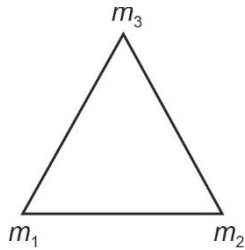

$$U = \frac{-Gm_1 m_2}{r} - \frac{Gm_1 m_3}{r} - \frac{Gm_2 m_3}{r}$$

$$= \frac{-G}{r} (1 \times 2 + 1 \times 3 + 2 \times 3)$$

$$= \frac{-6.67 \times 10^{-11} \times 11}{20 \times 10^{-2}}$$

$$= -3.7 \times 10^{-9} \text{ J}$$

30. Answer (1)

\$e = 1\$, for perfectly elastic collision
 \$e = 0\$, for perfectly inelastic collision
 \$0 < e < 1\$, inelastic collision

31. Answer (4)

The contribution of S. Chandrasekhar to Physics is structure and evolution of stars.

32. Answer (1)

$$\frac{v dm}{dt} = \rho a v^2$$

$$m_0 a_1 = \rho a v^2$$

$$A H \rho a_1 = \rho a 2gH$$

$$a_1 = \frac{2ag}{A}$$

33. Answer (4)

Thermal stress does not depend upon length of the rod.

34. Answer (3)

$$E \propto l$$

$$(E_1 + E_2) \propto l_1$$

$$(E_1 - E_2) \propto l_2$$

$$\frac{E_1 + E_2}{E_1 - E_2} = \frac{l_1}{l_2}$$

$$l_2 E_1 + l_2 E_2 = l_1 E_1 - l_1 E_2$$

$$(l_1 + l_2) E_2 - (l_1 - l_2) E_1$$

$$\frac{E_1}{E_2} = \frac{l_1 + l_2}{l_1 - l_2}$$

35. Answer (1)

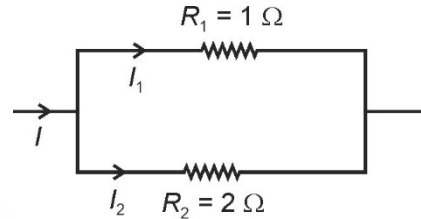

$$I_2 = \frac{I R_1}{R_1 + R_2}$$

$$= \frac{1 \times 1}{1 + 2}$$

$$= \frac{1}{3} \text{ A}$$

SECTION - B

36. Answer (4)

$$R = 10 \Omega$$

$$X_L = 0.2 \times 200 = 40 \Omega$$

$$\cos(\theta) = \frac{1}{\sqrt{2}} = \frac{R}{Z}$$

$$\Rightarrow |(X_L - X_C)| = R$$

If \$X_C < 40\$

$$\Rightarrow (40 - X_C) = 10 \Rightarrow X_C = 30 \Omega$$

If \$X_C > 40\$

$$\Rightarrow X_C - 40 = 10 \Rightarrow X_C = 50 \Omega$$

37. Answer (1)

$$A v_A = 10, A v_B = 15, A v_C = 20$$

$$\Delta V_i = 2 \times 10^{-3} \text{ V}$$

Total voltage amplification

$$= \frac{\text{output signal voltage}}{\text{input signal voltage}}$$

$$\Delta V_0 = \Delta V_i \times 10 \times 15 \times 20$$

$$= 2 \times 10^{-3} \times 10 \times 15 \times 20$$

$$= 6 \text{ V}$$

38. Answer (4)

$$\text{Resolving power (p)} \propto \frac{1}{\lambda}$$

$$\lambda_{\text{blue}} < \lambda_{\text{green}} < \lambda_{\text{yellow}} < \lambda_{\text{red}}$$

$$P_{\text{Blue}} > P_{\text{green}} > P_{\text{yellow}} > P_{\text{red}}$$

39. Answer (2)

$$V = lbh = 1.61 \times 2.2 \times 3.1$$

$$= 10.9802 \text{ m}^3$$

$$= 1.1 \times 10^1 \text{ m}^3$$

(i.e. upto 2 significant figures)

40. Answer (3)

Magnetic field due to straight wires will cancel out

$$\text{Magnetic field due to circular section} = \frac{\mu_0 i}{4R}$$

41. Answer (2)

$$\text{K.E.} = \frac{1}{2}kA^2 - \frac{1}{2}k\left[\frac{A}{2}\right]^2$$

$$= \frac{3}{8}kA^2$$

$$\text{P.E.} = \frac{1}{2}k\frac{A^2}{4}$$

$$\frac{\text{K.E.}}{\text{P.E.}} = \frac{3}{1}$$

42. Answer (2)

$$\frac{kQ}{r} = V$$

$$V' = \frac{k(64Q)}{4r}$$

$$= \frac{16kQ}{r}$$

$$n = 16$$

43. Answer (1)

$$\text{In } y = A\sin(\omega t - kx)$$

$$v = \frac{\omega}{k}$$

$$v = \frac{8}{1/4} = 32 \text{ m/s}$$

44. Answer (4)

We know that, PE = 2 T.E \Rightarrow P.E = -27.2 eV

45. Answer (2)

$$I = \frac{V}{R}$$

$$I - \frac{1}{2} = \frac{V}{R+4}$$

$$\frac{V}{R} - \frac{1}{2} = \frac{V}{R+4}$$

$$\frac{V}{R} - \frac{V}{R+4} = \frac{1}{2}$$

$$12\left(\frac{1}{R} - \frac{1}{R+4}\right) = \frac{1}{2}$$

$$12\left(\frac{R+4-R}{R(R+4)}\right) = \frac{1}{2}$$

$$96 = R(R+4)$$

$$R = 8 \Omega$$

46. Answer (1)

$$E_x = -\frac{\partial V}{\partial x}$$

$$E_x = -\frac{\partial(3x^2)}{\partial x}$$

$$E_x = -6x$$

$$E_x = -6 \times 3$$

$$= -18 \frac{\text{V}}{\text{m}}$$

47. Answer (3)

$$12 = \frac{q_0}{4} + \frac{q_0}{8}$$

$$12 = \frac{3q_0}{8}$$

$$q_0 = 32 \mu\text{C}$$

$$V = \frac{q_0}{C}$$

$$= \frac{32}{4}$$

$$= 8 \text{ V}$$

48. Answer (1)

$$B = \sqrt{B_V^2 + B_H^2}$$

$$= \sqrt{(0.4 \times 10^{-4})^2 + (0.3 \times 10^{-4})^2}$$

$$= 0.5 \times 10^{-4} \text{ T}$$

49. Answer (3)

$$\frac{1}{\lambda} = R\left(\frac{1}{n_i^2} - \frac{1}{n_f^2}\right)$$

$$\frac{1}{\lambda_{\text{max}}} = R\left(\frac{1}{4} - \frac{1}{9}\right)$$

$$\lambda_{\max} = \frac{36}{5R}$$

$$\lambda_{\min} = \frac{4}{R}$$

$$\frac{\lambda_{\max}}{\lambda_{\min}} = \frac{9}{5}$$

50. Answer (4)

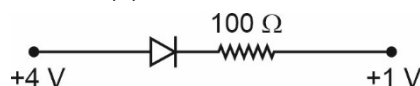

$$I = \frac{4-1}{100}$$

$$= 30 \times 10^{-3} \text{ A}$$

$$= 30 \text{ mA}$$

CHEMISTRY

SECTION - A

51. Answer (3)

Due to metal excess defect, NaCl crystal shows yellow colour on heating.

52. Answer (2)

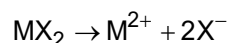

$$\alpha = \frac{i-1}{n-1} \Rightarrow \frac{2-1}{3-1} = \frac{1}{2} = 0.5$$

53. Answer (3)

NO in brown ring complex has +1 oxidation state.

$$\text{So, } x + (0 \times 5) + (1 \times 1) = +2$$

$$x = +1$$

54. Answer (3)

$$\eta = \frac{\Delta G}{\Delta H} = \text{thermodynamic efficiency of fuel cell.}$$

55. Answer (3)

$$\text{Mole} = \frac{\text{Weight in gm}}{\text{Molar mass}}$$

Moles are independent of volume.

56. Answer (3)

$$4 \text{ g of H}_2 = 2 \text{ moles of H}_2 = 2 \times N_A \text{ molecules}$$

$$32 \text{ g of O}_2 = 1 \text{ mole of O}_2 = 1 \times N_A \text{ molecules}$$

$$3 \text{ moles of H}_2\text{O} = 3 \times N_A \text{ molecules}$$

$$22.4 \text{ L of CO}_2 \text{ at STP} = 1 \text{ mole of CO}_2 = 1 \times N_A \text{ molecules.}$$

57. Answer (2)

- Higher is the $(n + l)$ value of an orbital, higher will be its energy.
- If $(n + l)$ value is same then higher the value of n , higher will be its energy.

58. Answer (3)

The value of l can be 0 to $(n - 1)$

59. Answer (3)

For first order reaction

$$t = \frac{2.303}{k} \log \frac{[A_0]}{[A_t]}$$

$$= \frac{2.303}{0.693} \log \frac{x}{\frac{x}{16}}$$

$$= \frac{2.303 \times 10}{0.693} \times 4 \log 2$$

$$= \frac{2.303 \times 10 \times 4 \times 0.3010}{0.693} \approx 40 \text{ min}$$

60. Answer (3)

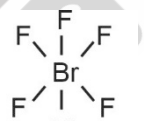

5 bond pairs

+

1 lone pair

61. Answer (3)

Molecular orbital configuration of O_2^- (17 electrons)

$$\sigma 1s^2 \sigma^* 1s^2 \sigma 2s^2 \sigma^* 2s^2 \sigma 2p_z^2 \left\{ \begin{array}{l} \pi 2p_x^2 \\ \pi 2p_y^2 \end{array} \right\} \left\{ \begin{array}{l} \pi^* 2p_x^2 \\ \pi^* 2p_y^1 \end{array} \right\}$$

$$\text{Bond order} = \frac{1}{2} [N_b - N_a]$$

$$= \frac{1}{2} (10 - 7)$$

$$= 1.5$$

62. Answer (2)

$$\frac{P_{\text{H}_2}}{P_{\text{total}}} = \frac{P_{\text{H}_2}}{P_{\text{H}_2} + P_{\text{CH}_4}} = \frac{X_{\text{H}_2} \times P_{\text{total}}}{X_{\text{H}_2} \times P_{\text{total}} + X_{\text{CH}_4} \times P_{\text{total}}}$$

$$= \frac{\frac{n_{H_2}}{n_{H_2} + n_{CH_4}}}{\frac{n_{H_2}}{n_{H_2} + n_{CH_4}} + \frac{n_{CH_4}}{n_{H_2} + n_{CH_4}}}$$

$$= \frac{n_{H_2}}{n_{H_2} + n_{CH_4}}$$

Let the mass of H₂ and CH₄ be w gram each

$$= \frac{\frac{w}{2}}{\frac{w}{2} + \frac{w}{16}} = \frac{8}{9}$$

63. Answer (4)

Kinetic energy is a function of temperature only.

64. Answer (1)

Work is a path function.

65. Answer (2)

$$\Delta U = q + w$$

$$= -20 + 10 = -10 \text{ J}$$

66. Answer (2)

$$\Delta G = \Delta H - T\Delta S$$

At equilibrium, $\Delta G = 0$

$$\therefore \Delta H = T\Delta S$$

$$T = \frac{\Delta H}{\Delta S} = \frac{37500 \text{ J mol}^{-1}}{150 \text{ J K}^{-1} \text{ mol}^{-1}}$$

$$= 250 \text{ K}$$

67. Answer (2)

If the reaction is reversed, the value of equilibrium constant is reciprocated. Also, if the reaction is multiplied by a factor (n) then the value of equilibrium constant becomes $K'_C = (K_C)^n$

68. Answer (4)

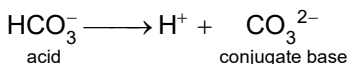

69. Answer (1)

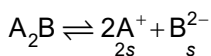

$$K_{sp} = [A^+]^2 [B^{2-}]$$

$$1.08 \times 10^{-16} = (2s)^2 s$$

$$108 \times 10^{-18} = 4s^3$$

$$27 \times 10^{-18} = s^3$$

$$3 \times 10^{-6} \text{ mol L}^{-1} = s$$

70. Answer (3)

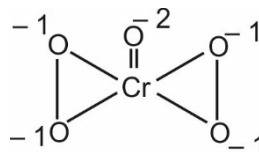

$$x + 4(-1) + (-2) = 0$$

$$x = +6$$

71. Answer (4)

Higher is the negative value of standard reduction potential, stronger is the reducing power.

72. Answer (4)

Both assertion and reason are wrong.

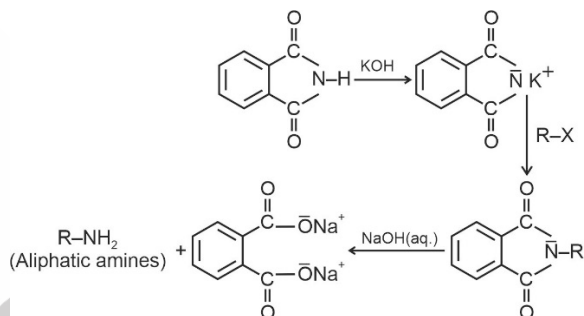

Aromatic primary amines cannot be prepared by this method because aryl halides do not undergo nucleophilic substitution with the anion formed by phthalimide.

73. Answer (1)

The hydration enthalpy of alkali metals ions decreases with increase in ionic sizes.

74. Answer (4)

NaHCO₃ is baking soda

Na₂CO₃·10H₂O is washing soda

CaSO₄·2H₂O is gypsum.

CaSO₄·½H₂O is Plaster of Paris.

75. Answer (4)

Element	$\Delta_f H$ (kJ/mol)
B	801
Al	577
Ga	579
In	558
Tl	589

76. Answer (1)

CO₂ : Acidic

Al₂O₃ : Amphoteric

CO : Neutral

Na₂O : Basic

77. Answer (2)

$$[H^+] = 10^{-2} \text{ M}$$

$$\text{pH} = -\log[H^+] \\ = 2$$

$$\therefore \text{pOH} = 14 - 2 = 12$$

78. Answer (2)

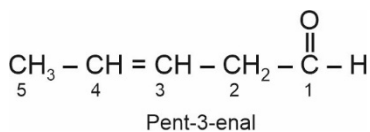

79. Answer (2)

cyclic, 6π electrons, Aromatic.

80. Answer (4)

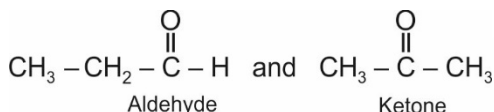

are functional isomers

81. Answer (2)

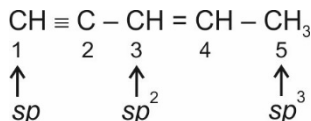

82. Answer (2)

% of nitrogen in the organic compound

$$= \frac{1.4 \times 20 \times 0.5 \times 2}{1} = 28\%$$

83. Answer (2)

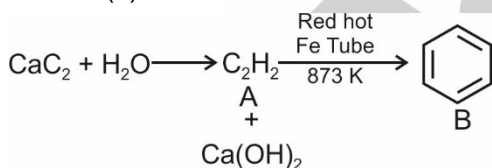

84. Answer (2)

When soap mixed with water above critical micelle concentration then it forms associated colloid and below CMC they act as normal electrolyte.

85. Answer (3)

In Li_2O , O^{2-} ions forms CCP structure and Li^+ ions are present in all tetrahedral voids.

SECTION - B

86. Answer (2)

$$\begin{aligned} \Delta T_f &= i \times m \times K_f \\ &= 1 \times \frac{30 \times 100}{60 \times 500} \times 1.86 \\ &= 1.86 \end{aligned}$$

$$\begin{aligned} T_f &= T_f^\circ - \Delta T_f \\ &= 0^\circ\text{C} - 1.86^\circ\text{C} \\ &= -1.86^\circ\text{C} \end{aligned}$$

87. Answer (3)

In galvanisation process, iron is covered with Zn.

88. Answer (3)

When the reactants, products and catalyst are in the same phase, the process is said to be homogeneous catalysis.

89. Answer (4)

When the reaction is carried out in solvents of low polarity such as CHCl_3 or CS_2 and at low temperature, monobromophenols are formed.

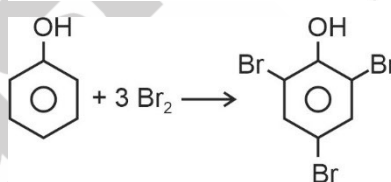
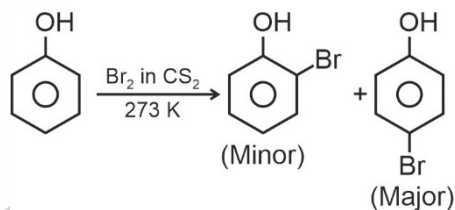

90. Answer (2)

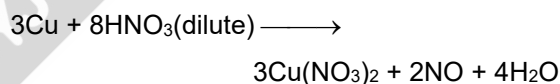

91. Answer (1)

$\text{Cr}_2\text{O}_7^{2-}$ is orange coloured due to charge transfer from ligand to metal.

92. Answer (3)

Ligands which has two different donor atoms and either of the two ligates in the complex is called ambidentate ligand.

93. Answer (4)

Presence of electron withdrawing group decreases the electron density on the ring and hence increases its reactivity towards aromatic nucleophilic substitution.

94. Answer (2)

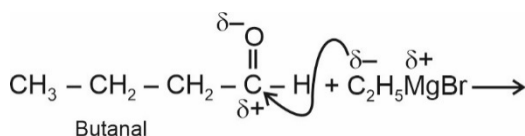

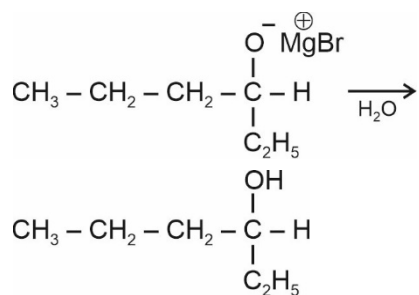

95. Answer (3)

For aldol condensation, at least 2 α - H must be present.

96. Answer (2)

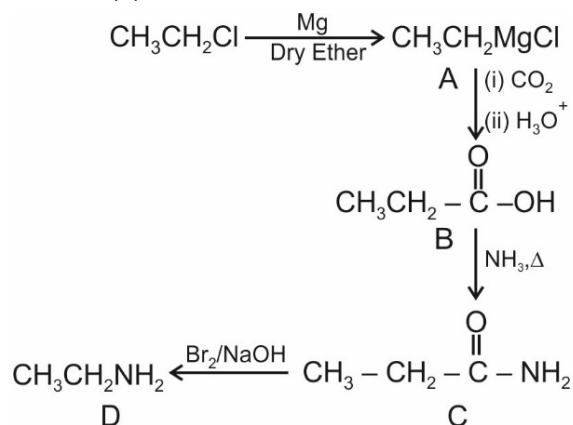

97. Answer (2)

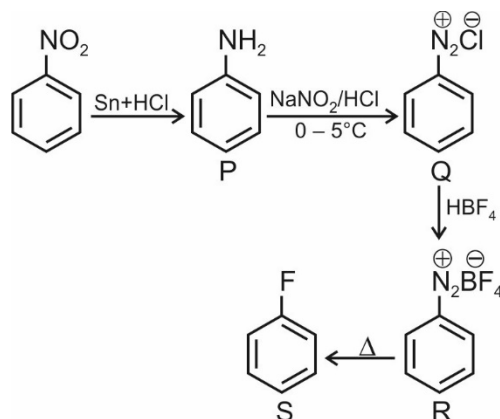

98. Answer (2)

Maltose is composed of two α -D-glucose units.

99. Answer (1)

Terylene is a polymer of ethylene glycol and terephthalic acid.

100. Answer (4)

Alitame is 1000 times more sweet than cane sugar.

BOTANY

SECTION - A

101. Answer (2)

Gamete is haploid and pollen mother cell is diploid.

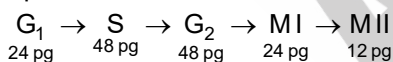

102. Answer (2)

In metaphase, condensation of chromosomes is completed and their morphology is most easily studied.

103. Answer (4)

Isobrachial (metacentric) chromosome appears V - shaped during anaphase.

104. Answer (1)

Centrioles show 9 + 0 arrangement of microtubules giving a cartwheel like appearance.

105. Answer (3)

Wheat is categorised under class monocotyledonae.

106. Answer (4)

Planaria (flat worm) shows true regeneration.

Hydra reproduce through budding.

107. Answer (3)

Thylakoids are flat membranous sacs which are arranged in stack known as granum.

Two grana are connected with the help of flat membranous tubules known as stroma lamellae.

Stroma contains 70S ribosomes.

108. Answer (2)

In monocotyledonous seed, the plumule and radicle are enclosed in sheath which are called coleoptile and coleorhiza respectively.

109. Answer (1)

Flowers of bean show vexillary aestivation and flowers of China rose show twisted aestivation.

110. Answer (2)

The dead component of phloem is phloem fibre.

111. Answer (1)

Hypodermis is absent in roots.

112. Answer (2)

Red algae reproduce asexually by non-motile spores.

e.g. - *Polysiphonia*, *Porphyra*

113. Answer (1)

Mannitol is found in members of brown algae like *Dictyota*

114. Answer (2)

Prions cause mad cow disease.

115. Answer (4)

Morels and truffles are edible ascocarps.

Fungi prefer to grow in warm and humid places. They have cell wall.

Saccharomyces is commercially used in baking.

116. Answer (3)

Turner's syndrome is sexual monosomy that is 44 + XO.

117. Answer (2)

Simple diffusion does not require any membrane protein. Facilitated diffusion is not energy dependent.

118. Answer (3)

Nitrosomonas and *Nitrobacter* are chemoautotrophs as they use chemical energy released during oxidation of inorganic substances.

119. Answer (2)

ATP formation takes place in both.

120. Answer (3)

During activation phase of glycolysis, two molecules of ATP are used.

121. Answer (4)

Gibberellins induce bolting in rosette habit plants.

122. Answer (4)

The progenitor of the next generation in mature seed is embryo.

123. Answer (3)

Cells of middle layers of anther wall are short lived that is ephemeral in nature.

124. Answer (2)

XX – XO type of sex determination is seen in grasshopper, while XX – XY type of sex determination can be seen in insects like *Drosophila* and mammals including human beings.

125. Answer (4)

Flower colour in *Antirrhinum majus* is an example of incomplete dominance.

126. Answer (1)

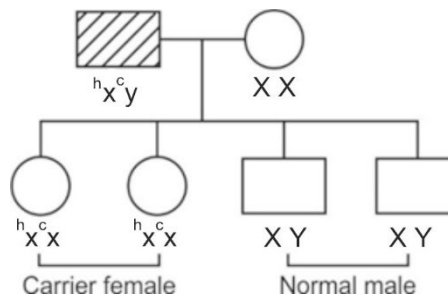

According to the pedigree, no son is found to be affected with hemophilia.

127. Answer (3)

VNTRs are minisatellites.

128. Answer (3)

During transcription, the dsDNA helix is unwinded by the enzyme RNA polymerase.

129. Answer (1)

(a) DNA polymerase is involved in DNA replication.

(b) RNA polymerase is involved in transcription.

(c) Peptidyl transferase is involved in translation.

130. Answer (3)

The productivity of oceans is 55 billion tons and for terrestrial ecosystem the productivity is 115 billion tons.

131. Answer (3)

In the urn-shaped age pyramid for human population the number of individuals of different age group will be

Pre reproductive < Reproductive > Post-reproductive

132. Answer (3)

Newly created ponds, igneous rocks and sand dunes can start primary succession.

133. Answer (1)

LAB play very beneficial role in checking disease causing microbes in our stomach.

134. Answer (4)

Water hyacinth leads to an imbalance in the ecosystem dynamics

135. Answer (1)

Montreal Protocol aimed at controlling emission of ozone depleting substances.

SECTION - B

136. Answer (4)
Deuteromycetes are commonly called imperfect fungi as they lack sexual reproduction.
137. Answer (2)
Phloem parenchyma is not seen in phloem of monocots and it stores food material and other substances like resins latex and mucilage.
138. Answer (3)
Guava shows opposite phyllotaxy in which two leaves arise from each node.
139. Answer (1)
Agar is one of the commercial products obtained from *Gelidium* and *Gracilaria*.
140. Answer (3)
The process of absorption of water by hydrophilic solid particles of a substance without forming a solution is called imbibition.
141. Answer (3)
Ethylene is only gaseous phytohormone. It promotes root growth and root hair formation.
142. Answer (3)
70S type of ribosomes are not seen in cytoplasm of eukaryotic cells. Cytoplasmic ribosomes in eukaryotes are 80S type.
143. Answer (3)
In the given diagram

- A. Represents radicle
B. Represents plumule
C. Represents hypocotyl

144. Answer (2)
Prions are acellular and cause bovine spongiform encephalopathy in cattles.
145. Answer (1)
Whisky, brandy and rum are produced by distillation.
146. Answer (2)
The codon 'GUG' cannot terminate translation process.
147. Answer (4)
Organisms that live in areas where the temperature is uniform throughout the year are stenothermal.
148. Answer (1)
Stratification is structural aspect of ecosystem and productivity is functional aspect of ecosystem.
149. Answer (3)
Most important cause of biodiversity loss is habitat loss and fragmentation.
150. Answer (1)
El Nino effect is related with enhanced greenhouse effect, global warming leading to climate change.

ZOOLOGY

SECTION - A

151. Answer (3)
LH surge induces ovulation and triggers corpus luteum to release estrogen and progesterone.
152. Answer (2)
Tetany – Rapid spasms (wild contractions) in muscles due to low Ca^{2+} in body fluid.
Myasthenia gravis – Auto-immune disorder affecting neuromuscular junctions leading to fatigue, weakening and paralysis of skeletal muscles.
153. Answer (3)
Folliculogenesis is inhibited during pregnancy.
In addition, during pregnancy the levels of other hormones like estrogens, progestogens, cortisol, prolactin, thyroxine, etc., are increased several folds in the maternal blood. Increased production

of these hormones is essential for supporting the foetal growth, metabolic changes in the mother and maintenance of pregnancy.

154. Answer (1)
In artificial passive immunity, readymade antibodies formed against a particular antigen/pathogen are introduced in our body through immunisation.
155. Answer (2)
In electrical synapses, the membranes of pre and post synaptic neurons are in very close proximity and electrical current can flow directly from one neuron to another neuron.
156. Answer (3)
A deep cleft divides the cerebrum longitudinally into two halves which are connected by a tract of nerve fibers called corpus callosum.

157. Answer (1)

Ligaments attach one bone to another bone.

158. Answer (1)

Glucose is completely absorbed in the PCT.

ADH helps in water reabsorption, making the urine hypertonic.

159. Answer (3)

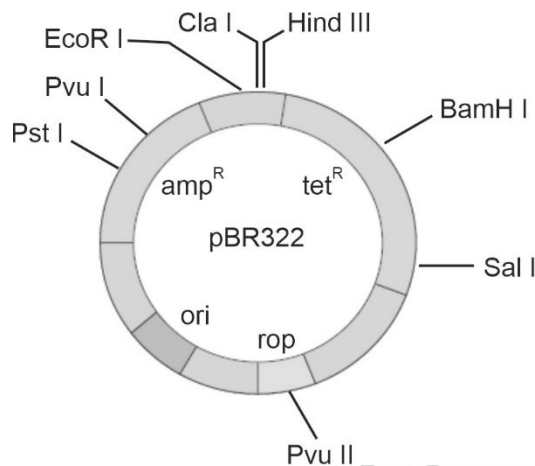

160. Answer (3)

Knee jerk reflex is a monosynaptic/simple reflex; so, interneurons are not involved.

161. Answer (3)

Nitrogenous bases – adenine, guanine, cytosine, uracil and thymine, when found attached to a sugar, they are called nucleosides. If a phosphate group is also found esterified to the same sugar, they are called nucleotides.

162. Answer (1)

Transfer of an ovum collected from a donor into the fallopian tube (GIFT – gamete intra fallopian transfer) of another female who cannot produce one, but can provide suitable environment for fertilisation and further development is another method attempted. Intra Cytoplasmic Sperm Injection (ICSI) is another specialised procedure to form an embryo in the laboratory in which a sperm is directly injected into the ovum. Infertility cases either due to inability of the male partner to inseminate the female or due to very low sperm counts in the ejaculates, could be corrected by artificial insemination (AI) technique.

163. Answer (3)

Residual volume (RV) is the volume of air remaining in the lungs even after a forcible expiration.

This averages 1100 mL to 1200 mL.

$$IC = TV + IRV$$

$$FRC = ERV + RV$$

164. Answer (1)

ANF decreases blood pressure by causing dilation of blood vessels. It is secreted when blood pressure increases.

165. Answer (4)

The blood concentration of glucose in a normal healthy individual is 4.2 mmol/L-6.1 mmol/L.

166. Answer (1)

Osteichthyes or bony fishes show the presence of air bladder, separate sexes and external fertilization.

167. Answer (2)

Bt toxin is produced as an inactive/precursor form that gets activated in the alkaline pH of the gut of insects.

168. Answer (3)

Malonate is the competitive inhibitor of succinate.

169. Answer (1)

Efferent arteriole emerges from glomerulus. Cortical nephrons have a short loop of Henle and they are more in number.

PCT and DCT are the coiled regions of nephrons.

170. Answer (1)

$$p^2 = AA = \frac{490}{1000} \therefore p = \sqrt{\frac{490}{1000}} = 0.7$$

$$q = 1 - p = 1 - 0.7 = 0.3$$

$$Aa = 2pq = 2 \times 0.7 \times 0.3 = 420$$

$$q^2 = aa = .3 \times .3 = .09 \times 1000 = 90$$

171. Answer (3)

Corpus luteum secretes progesterone in luteal phase.

172. Answer (4)

The embryo with 8 to 16 blastomeres is called a morula. The morula continues to divide and transforms into the blastocyst as it moves further into the uterus.

173. Answer (3)

The two enzymes isolated from *E.coli* were responsible for restricting the growth of bacteriophages, where one added methyl groups to DNA and the other cut DNA at specific sites.

174. Answer (3)

They absorb nitrogenous waste products and convert them into uric acid which is excreted out through the hindgut. Therefore, this insect is called uricotelic.

175. Answer (1)

Facial bones = 14

Cranial bones = 8

Cervical vertebrae = 7

176. Answer (3)

The toxin coded by the gene *cryIAc* is named protoxin. Toxins encoded by the genes *cryIAc* and *cryIIAb* control the cotton bollworms.

177. Answer (3)

Neutrophils are the most abundant cells (60 – 65%) of the total WBCs and basophils are the least (0.5 – 1%) among them.

178. Answer (2)

pO_2 in systemic vein and pulmonary artery = 40 mm Hg. pCO_2 in systemic artery = 40 mm Hg.

179. Answer (4)

The oviducts (fallopian tubes), uterus and vagina constitute the female accessory ducts. Mons pubis and clitoris are the parts of female external genitalia.

180. Answer (2)

LH surge induces ovulation. The corpus luteum secretes large amount of progesterone which is essential for maintenance of the endometrium.

181. Answer (3)

Enzyme Linked Immuno-sorbent Assay is based on antigen-antibody interaction.

182. Answer (1)

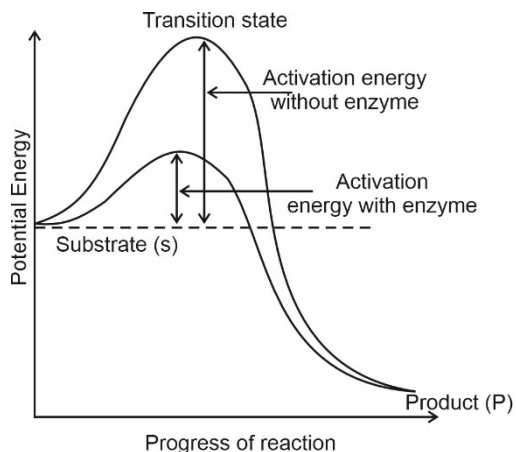

Enzymes lower the activation energy required for a reaction.

183. Answer (1)

Australian marsupials show adaptive radiation and divergent evolution.

184. Answer (3)

Thyroid calcitonin (TCT) regulates the blood calcium level and is produced by the thyroid gland.

185. Answer (3)

Hugo deVries proposed the idea that mutation caused speciation and hence called it saltation (single step large mutation).

186. Answer (3)

Inbreeding helps in accumulation of superior genes and elimination of less desirable genes. It increases homozygosity and thus is necessary to evolve a pure line.

187. Answer (3)

Tightly bound cofactors are prosthetic groups.

188. Answer (3)

Tunica interna of arteries is called endothelium. Tunica media is mainly responsible for vasoconstriction.

189. Answer (4)

Amphioxus belongs to the subphylum Cephalochordata. Notochord is present only in the larval tail of urochordates like *Ascidia*, *Salpa*, etc.

190. Answer (2)

The blastocyst becomes embedded in the endometrium of uterus is called implantation. Embryo with 8 to 16 blastomeres is called morula.

191. Answer (1)

In myocardial ischaemia, O_2 supply is reduced which further results in myocardial infarction.

192. Answer (1)

Copper releasing IUDs – CuT, Cu7, Multiload 375
Hormone releasing IUDs – Progestasert, LNG-20
Non-medicated IUDs – Lippes loop

Diaphragms, cervical caps and vaults are barriers for sperms that are inserted into the female reproductive tract.

193. Answer (3)

Fusion of gametes within the female is done in Gamete Intra Fallopian Transfer (GIFT) of a female who cannot produce gametes but can provide suitable environment for fertilization and further development after implantation.

194. Answer (3)

All monosaccharides are reducing sugars. Adenine and guanine, both are present in nucleic acids.

195. Answer (1)

Gastric juice is highly acidic (pH 1.8)

196. Answer (3)

Branchiostoma (Amphioxus or lancelet) is a Cephalochordate.

197. Answer (2)

Ascaris, *Wuchereria* and *Ancylostoma* are members of phylum Aschelminthes and have the pseudocoelom derived from embryonic blastocoel.

198. Answer (2)

Adrenal medulla secretes two hormones called adrenaline and noradrenaline. These are commonly called catecholamines. These are rapidly secreted in response to stress of any kind

and during emergency situations and are called emergency hormones or hormones of fight or flight.

199. Answer (3)

H-zone is present at the centre of A-band. A-Band consists of both thick and thin filaments.

200. Answer (2)

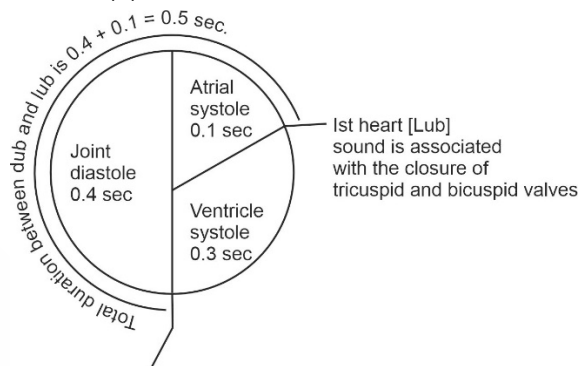

Second heart sound is dub, it is associated with the closure of semilunar valves.