

DATE : 03/05/2026

Test Booklet Code



14

KAILASH

Corporate Office : 3rd Floor, Incuspaze Campus-2, Plot No. 13,
Sector-18, Udyog Vihar, Gurugram, Haryana - 122015.

Questions & Answers for NEET (UG)-2026

Time : 3 hrs.

M.M. : 720

Important Instructions:

1. The test is of **3 hours** duration and the Test Booklet contains **180** multiple choice questions (Four options with a single correct answer) from **Physics, Chemistry and Biology (Botany and Zoology)**.
2. Each question carries **4 marks**. For each correct response, the candidate will get **4 marks**. For every wrong response, **1 mark** shall be deducted from the total scores. The maximum marks are **720**.
3. Use **Blue / Black Ball Point Pen only** for writing particulars on this page / marking responses on Answer Sheet.
4. Rough work is to be done in the space provided for this purpose in the Test Booklet only.
5. On completion of the test, the candidate must handover the Answer Sheet to the Invigilator before leaving the Room / Hall. The candidates are allowed to take away this Test Booklet with them.
6. The CODE for this Booklet is **14**.
7. The candidates should ensure that the Answer Sheet is not folded. Do not make any stray marks on the Answer Sheet. Do not write your Roll No. anywhere else except in the specified space in the Test Booklet/Answer Sheet. Use of white fluid for correction is **NOT** permissible on the Answer Sheet.
8. Each candidate must show on demand his/her Admission Card to the Invigilator.
9. No candidate, without special permission of the Centre Superintendent or Invigilator, would leave his/her seat.
10. Use of Electronic/Manual Calculator is prohibited.
11. The candidates are governed by all Rules and Regulations of the examination with regard to their conduct in the Examination Hall. All cases of unfair means will be dealt with as per Rules and Regulations of this examination.
12. No part of the **Test Booklet** and **Answer Sheet** shall be detached under any circumstances.
13. The candidates will write the Correct Test Booklet Code as given in the Test Booklet / Answer Sheet in the Attendance Sheet.

PHYSICS

1. The following plots show variation of velocity (v) with time (t) of a ball thrown vertically upward, and falling back. Which of the following plots is/are correct?

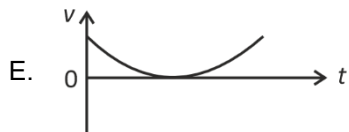
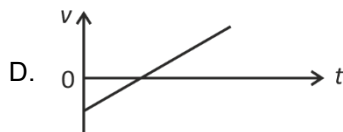
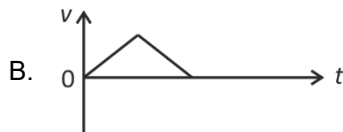
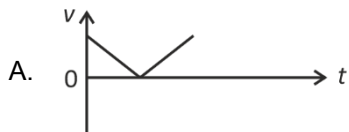

- (1) B only
(2) A and E only
(3) D only
(4) C only

Answer (4)

2. For a metal of work function 6.6 eV, which of the following wavelengths of incident radiation does **not** give rise to the photoelectric effect?

(Take Planck's constant as 6.6×10^{-34} J s)

- (1) 50 nm
(2) 100 nm
(3) 150 nm
(4) 200 nm

Answer (4)

3. The power of a crane, which lifts a mass of 1000 kg to a height of 20 m in 10 s is: ($g = 9.8$ m/s²)

- (1) 39.2 kW
(2) 39.2 W
(3) 19.6 kW
(4) 19.6 W

Answer (3)

4. Match List I with List II.

| | List-I | | List-II |
|----|------------------------------|------|--------------------------|
| A. | $E = h\nu$ | I. | de Broglie wavelength |
| B. | Diffraction and Interference | II. | Particle nature of light |
| C. | $\lambda = h/p$ | III. | Wave nature of light |
| D. | Compton effect | IV. | Energy of photon |

Choose the **correct** answer from the options given below.

- (1) A-IV, B-I, C-II, D-III
(2) A-I, B-IV, C-III, D-II
(3) A-IV, B-III, C-II, D-I
(4) A-IV, B-III, C-I, D-II

Answer (4)

10. A submarine is designed to withstand an absolute pressure of 100 atm. How deep can it go below the water surface?

(Consider the density of water = 1000 kg m^{-3} ,
1 atm = $1 \times 10^5 \text{ Pa}$ and gravitational acceleration $g = 10 \text{ m/s}^2$)

- (1) 990 m (2) 9000 m
(3) 99 m (4) 9900 m

Answer (1)

11. An electric heater supplies heat to a system at a rate of 100 W. If the system performs work at a rate of 75 J/s, then the rate at which internal energy increases will be:

- (1) 125 W (2) 75 W
(3) 100 W (4) 25 W

Answer (4)

12. A 100-turn closely wound circular coil of radius 5 cm has a magnetic field of $3.14 \times 10^{-3} \text{ T}$ at its centre. The current flowing through the coil, and the magnitude of the magnetic moment of this coil are, respectively :

(Take $\mu_0 = 4\pi \times 10^{-7} \text{ T m/A}$)

- (1) 2 A, 4 A m² (2) 2.5 A, 20 A m²
(3) 2.5 A, 2 A m² (4) 2 A, 10 A m²

Answer (3)

13. In Young's double slit experiment, using monochromatic light of wavelength λ , the intensity of light at a point on the screen where the path difference is λ , is K units. The intensity of light at a point where the path difference is $\frac{\lambda}{3}$ will be

- (1) $\frac{K}{2}$ (2) $2K$
(3) $\frac{K}{4}$ (4) K

Answer (3)

14. The current I in the circuit shown below is:

(All diodes are ideal and identical)

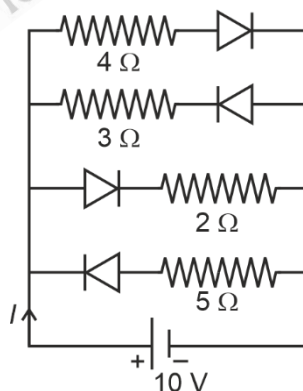

- (1) $\frac{5}{3} \text{ A}$ (2) $\frac{5}{9} \text{ A}$
(3) $\frac{15}{2} \text{ A}$ (4) $\frac{1}{3} \text{ A}$

Answer (3)

15. In a concave lens, a ray of light emanating from the object parallel to the principal axis of the lens after refraction:

- (1) passes through the second principal focus.
- (2) appears to diverge from the first principal focus.
- (3) emerges parallel to the principal axis.
- (4) passes through $2F$, which is the radius of curvature of the lens.

Answer (2*)

16. A galvanometer of resistance 100Ω gives full scale deflection for a current of 1 mA . It is converted into an ammeter of range $0 - 10 \text{ A}$. The shunt required is:

- (1) 0.10Ω
- (2) 0.001Ω
- (3) 1.0Ω
- (4) 0.01Ω

Answer (4)

17. In the first excited state of hydrogen atom, the energy of its electron is -3.4 eV . The radial distance of the electron from the hydrogen nucleus in this case is approximately:

(Take $1 \text{ eV} = 1.6 \times 10^{-19} \text{ J}$, $e = 1.6 \times 10^{-19} \text{ C}$ and $\frac{1}{4\pi\epsilon_0} = 9 \times 10^9 \text{ N m}^2/\text{C}^2$)

- (1) $2.1 \times 10^{-11} \text{ m}$
- (2) $2.1 \times 10^{-10} \text{ m}$
- (3) $2.1 \times 10^{-9} \text{ m}$
- (4) $2.1 \times 10^{-8} \text{ m}$

Answer (2)

18. The amount of work done to raise a mass ' m ' from the surface of the Earth to a height equal to the radius of the Earth ' R ' will be

- (1) mgR
- (2) $2 mg R$
- (3) $mg \frac{R}{4}$
- (4) $mg \frac{R}{2}$

Answer (4)

19. An ac circuit contains a resistance of $1 \text{ k}\Omega$, a capacitor of $0.1 \mu\text{F}$ and an inductor of 1 mH connected in series. The resonance frequency of the circuit is approximately:

- (1) 13.5 kHz
- (2) 15.9 kHz
- (3) 10.1 kHz
- (4) 20.7 kHz

Answer (2)

20. Consider two uncharged capacitors of equal capacitance 200 pF . One of them is charged by a 100 V supply and disconnected. Now this capacitor is connected to the uncharged capacitor. The amount of electrostatic energy lost in the process is:

- (1) 1.0 J
- (2) 0.5 J
- (3) $1.0 \times 10^{-6} \text{ J}$
- (4) $0.5 \times 10^{-6} \text{ J}$

Answer (4)

21. A ray of monochromatic light is passing through an equilateral prism (ABC) as shown in the figure. The refracted ray (QR) is parallel to its base (BC) and the angle of incidence (i) is 50° . Then the angle of deviation (δ) is:

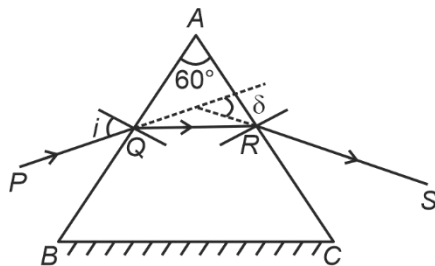

- (1) 45° (2) 40°
(3) 35° (4) 55°

Answer (2)

22. In a metre bridge experiment (see figure), the positions of the cell, E , and galvanometer, G , are interchanged. We shall observe in the galvanometer:

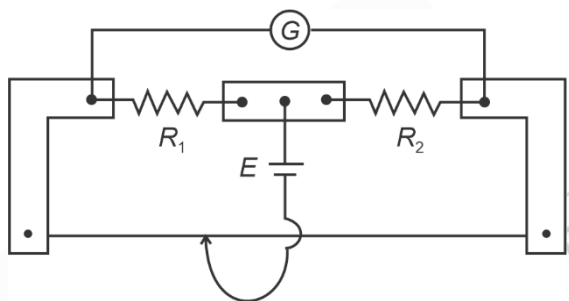

- (1) Only the left-sided deflection
(2) Both right-sided and left-sided deflection and at balance point, no deflection
(3) Only the right-sided deflection
(4) There will be no deflection irrespective of the position of the jockey

Answer (2)

23. A flask contains argon and chlorine in the ratio of 2 : 1 by mass. The temperature of the mixture is 27°C . The ratio of root mean square speed of the molecules of the two gases $\left(\frac{V_{\text{rms}}^{\text{Ar}}}{V_{\text{rms}}^{\text{Cl}}}\right)$ is:

(Atomic mass of argon = 40.0 u and molecular mass of chlorine = 70.0 u)

- (1) $\frac{7}{4}$
(2) $\frac{\sqrt{7}}{2}$
(3) $\frac{2}{\sqrt{7}}$
(4) $\frac{7}{2}$

Answer (2)

24. Two statements are given below:

- A. When the forward bias voltage across a p-n junction diode increases above a certain threshold voltage, the diode current increases significantly.
- B. This current is called reverse saturation current.

Choose the **correct** answer from the options given below:

- (1) Statement A is true, but Statement B is false (2) Both Statements A and B are true
- (3) Both Statements A and B are false (4) Statement A is false, but Statement B is true

Answer (1)

25. For a travelling harmonic wave

$y(x, t) = 2.0 \cos 2\pi(10t - 0.0080x + 0.35)$, where x and y are in cm and t in s. The phase difference between oscillatory motion of two points separated by a distance of 0.5 m is:

- (1) 0.8π rad (2) 8π rad
- (3) 0.008π rad (4) 0.08π rad

Answer (1)

26. A rectangular wire loop of sides 8 cm and 3 cm with a small cut, is moving out of a region of uniform magnetic field of magnitude 0.3 T directed normal to the plane of the loop. The emf developed across the cut, if the velocity of the loop is 2 cm s^{-1} , in a direction normal to the shorter side of the loop, will be :

- (1) 4.8×10^{-4} volt (2) 1.3×10^{-4} volt
- (3) 1.2×10^{-4} volt (4) 1.8×10^{-4} volt

Answer (4)

27. A thin wire of length ' L ' and linear mass density ' m ' is bent into a circular ring (in x-y plane) with centre ' C ' as shown in figure. The moment of inertia of the ring about an axis yy' will be :

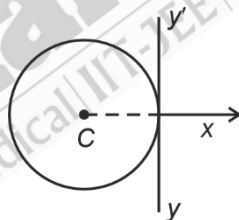

- (1) $\frac{3mL^2}{8\pi}$ (2) $\frac{3mL^2}{8\pi^2}$
- (3) $\frac{3mL^3}{8\pi}$ (4) $\frac{3mL^3}{8\pi^2}$

Answer (4)

28. A resistor is connected to a battery of 12 V emf and internal resistance 2Ω . If the current in the circuit is 0.6 A, the terminal voltage of the battery is:

- (1) 10.8 V
- (2) 1.2 V
- (3) 12 V
- (4) 10 V

Answer (1)

29. When a ruler falls vertically, 5 different persons catch it with different reaction times.

$(g = 9.8 \text{ m s}^{-2})$

- A. Person A has reaction time of 0.20 s.
- B. Person B has reaction time of 0.22 s.
- C. Person C has reaction time of 0.18 s.
- D. Person D has reaction time of 0.19 s.
- E. Person E has reaction time of 0.21 s.

What is the **correct** order of the distance travelled by the ruler for each person?

- (1) $C > D > A > E > B$
- (2) $C > D > A > B > E$
- (3) $B > E > A > D > C$
- (4) $B > E > A > C > D$

Answer (3)

30. The angular speed of a flywheel is increased from 600 rpm to 1200 rpm in 10 s. The number of revolutions completed by the flywheel during this time is :

- (1) 300
- (2) 150
- (3) 900
- (4) 600

Answer (2)

31. The figure given below shows a long straight solid wire of circular cross-section of radius 'a' carrying steady current I . The current I is uniformly distributed across its cross-section. The plot which correctly represents the variation of magnetic field (B) with distance (r) from the axis of the conductor in the region is :

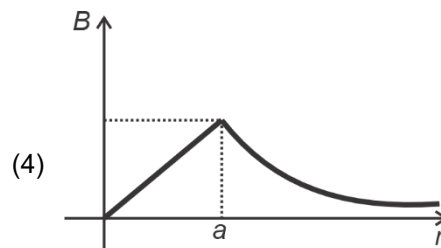
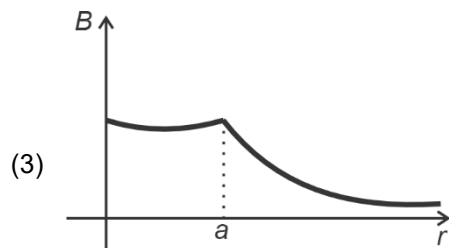
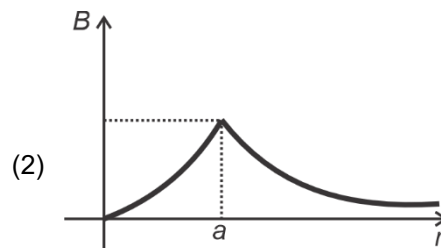
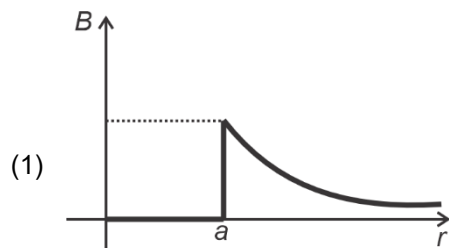

Answer (4)

32. Four statements are given (A is mass number):

- A. The volume of a nucleus is proportional to $A^{1/3}$.
- B. The volume of a nucleus is proportional to A .
- C. The difference in mass of an atom and its nucleus is called the mass defect.
- D. The difference in mass of a nucleus and its constituents is called the mass defect.

Choose the **correct** answer from the options given below:

- (1) A and D are true, but B and C are false
- (2) B and D are true, but A and C are false
- (3) B and C are true, but A and D are false
- (4) A and C are true, but B and D are false

Answer (2)

33. Savitha, a XI standard student, while conducting an experiment to determine the effective length of a simple pendulum L , notes down the data of time taken to complete 30 oscillations as 60 s and hence calculates the length of the simple pendulum as :

(Take $\pi^2 = 9.8$, and $g = 9.8 \text{ m/s}^2$)

- (1) 2 m
- (2) 1 m
- (3) 0.75 m
- (4) 1.5 m

Answer (2)

34. In a vernier calliper, 20 VSD coincide with 16 MSD (each division of length 1 mm). The least count of the vernier callipers is:

- (1) 0.1 cm
- (2) 0.02 cm
- (3) 0.01 cm
- (4) 0.2 cm

Answer (2)

35. Each side of a metallic cube of mass 5.580 kg is measured to the 9.0 cm. Keeping the significant figures in view, the density of the material of the cube can be best expressed as $X \times 10^3 \text{ kg m}^{-3}$ where the value of X is:

- (1) 7.654
- (2) 7.6
- (3) 7.65
- (4) 7.7

Answer (4)

36. In interference and diffraction, the light energy is redistributed. If it reduces in one region, producing a dark fringe, it increases in another region, producing a bright fringe.

- A. As there is no gain or loss of energy, these phenomena are consistent with the principle of conservation of energy.
- B. Diffraction and interference are characteristics exhibited only by light waves.

Choose the **correct** answer from the options given below:

- (1) A is false, but B is true
- (2) A is true and B is also true
- (3) A is true, but B is false
- (4) Both A and B are false

Answer (3)

37. Five capacitors of capacitances

$C_1 = C_2 = C_3 = C_4 = 10 \mu\text{F}$ and $C_5 = 2.5 \mu\text{F}$ are connected as shown, along with a battery of 50 V.

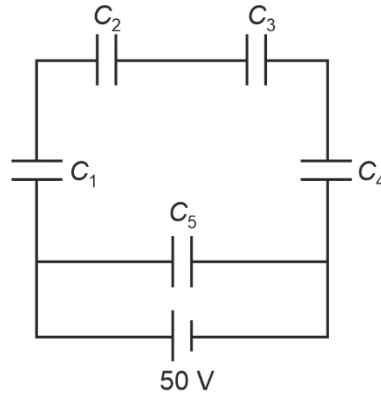

The equivalent capacitance and the charges on each capacitor respectively are:

- (1) $5 \mu\text{F}$, $125 \mu\text{C}$ on C_1 to C_4 and $25 \mu\text{C}$ on C_5 (2) $4 \mu\text{F}$, $250 \mu\text{C}$ on C_1 to C_4 and $125 \mu\text{C}$ on C_5
 (3) $5 \mu\text{F}$, $250 \mu\text{C}$ on all capacitors (4) $5 \mu\text{F}$, $125 \mu\text{C}$ on all capacitors

Answer (4)

38. For a simple pendulum, having time period T , the variation of kinetic energy (K.E.) with time (t) is represented by:

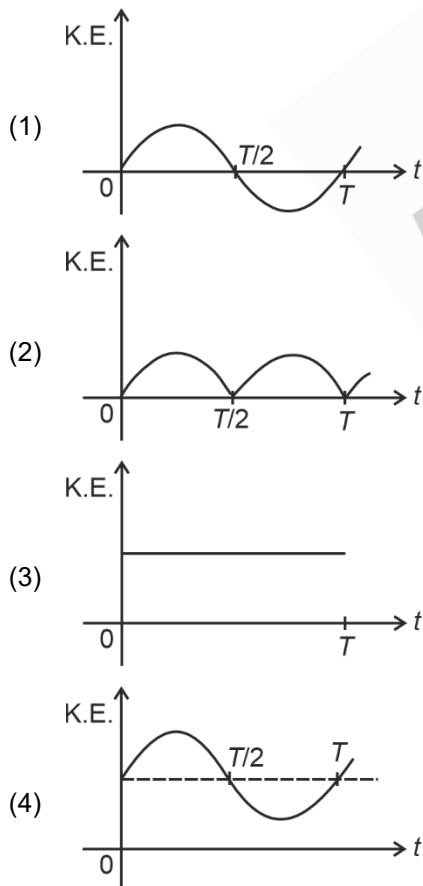

Answer (2)

39. A room heater is rated 400 W, 220 V. If the supply voltage drops to 200 V, what will be the power consumed (approximately)?

- (1) 121 W (2) 200 W
 (3) 400 W (4) 331 W

Answer (4)

40. The peak value of an alternating current is 5 A and frequency is 60 Hz. How long will the current, starting from zero, take to reach the peak value ?

- (1) $\frac{1}{60}$ s (2) $\frac{1}{240}$ s
 (3) $\frac{1}{30}$ s (4) $\frac{1}{120}$ s

Answer (2)

41. Which of the following statements are correct?

- A. Inside a conductor, the electrostatic field is zero.
 B. Electric field at the surface of a charged conductor does not depend on its surface charge density.
 C. The interior of a charged conductor can have no excess charge in the static situation.
 D. At the surface of a charged conductor, the electrostatic field must be normal to the surface at every point.
 E. The electrostatic potential is zero everywhere inside a charged conductor.

Choose the **correct** answer from the options given below:

- (1) A, C and D only (2) A, C and E only
 (3) C, D and E only (4) A, B and D only

Answer (1)

42. Match List I with List II:

| | List-I (Electromagnetic wave) | | List-II (Production) |
|----|--|------|---|
| A. | Microwave | I. | Electrons in atoms emit light when they move from a higher energy level to a lower energy level |
| B. | Visible light | II. | Radioactive decay of nucleus |
| C. | Gamma rays | III. | Vibration of atoms and molecules |
| D. | Infra-red rays | IV. | Klystron valve or magnetron valve |

Choose the **correct** answer from the options given below:

- (1) A-III, B-I, C-II, D-IV
 (2) A-III, B-IV, C-I, D-II
 (3) A-IV, B-I, C-II, D-III
 (4) A-IV, B-III, C-II, D-I

Answer (3)

43. A uniform metallic wire having resistance $4\ \Omega$ is bent to form a square loop ($ABCD$) (see figure). A resistance of $2\ \Omega$ is connected between points B and D and a battery of 2 V is connected across points A and C as shown in the figure. Now the value of current (I) is :

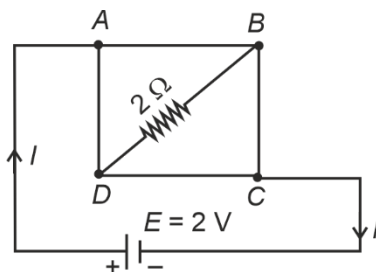

- (1) 4 A (2) 8 A
(3) 4.5 A (4) 2 A

Answer (4)

44. An unknown nucleus has a nuclear density of $2.29 \times 10^{17}\text{ kg/m}^3$ and mass of $19.926 \times 10^{-27}\text{ kg}$. Its mass number A is approximately:

(Take $R_0 = 1.2 \times 10^{-15}\text{ m}$, $4\pi = 12.56$)

- (1) 12 (2) 16
(3) 19 (4) 20

Answer (1)

45. Match List I with List II:

| | List I | | List II |
|----|-----------------|------|---|
| A. | Young's Modulus | I. | $\frac{\Delta d}{\Delta L} \left(\frac{L}{d} \right)$ |
| B. | Compressibility | II. | $\frac{FL}{A(\Delta L)}$ |
| C. | Bulk Modulus | III. | $-\frac{1}{\Delta P} \left(\frac{\Delta V}{V} \right)$ |
| D. | Poisson's Ratio | IV. | $-P \left(\frac{V}{\Delta V} \right)$ |

Choose the **correct** answer from the options given below:

- (1) A-II, B-III, C-IV, D-I
(2) A-III, B-II, C-I, D-IV
(3) A-I, B-IV, C-III, D-II
(4) A-IV, B-I, C-II, D-III

Answer (1)