

DATE : 03/05/2026

Test Booklet Code



13

KAILASH

Corporate Office : 3rd Floor, Incuspaze Campus-2, Plot No. 13,
Sector-18, Udyog Vihar, Gurugram, Haryana - 122015.

Questions & Answers for NEET (UG)-2026

Time : 3 hrs.

M.M. : 720

Important Instructions:

1. The test is of **3 hours** duration and the Test Booklet contains **180** multiple choice questions (Four options with a single correct answer) from **Physics, Chemistry and Biology (Botany and Zoology)**.
2. Each question carries **4 marks**. For each correct response, the candidate will get **4 marks**. For every wrong response, **1 mark** shall be deducted from the total scores. The maximum marks are **720**.
3. Use **Blue / Black Ball Point Pen only** for writing particulars on this page / marking responses on Answer Sheet.
4. Rough work is to be done in the space provided for this purpose in the Test Booklet only.
5. On completion of the test, the candidate must handover the Answer Sheet to the Invigilator before leaving the Room / Hall. The candidates are allowed to take away this Test Booklet with them.
6. The CODE for this Booklet is **13**.
7. The candidates should ensure that the Answer Sheet is not folded. Do not make any stray marks on the Answer Sheet. Do not write your Roll No. anywhere else except in the specified space in the Test Booklet/Answer Sheet. Use of white fluid for correction is **NOT** permissible on the Answer Sheet.
8. Each candidate must show on demand his/her Admission Card to the Invigilator.
9. No candidate, without special permission of the Centre Superintendent or Invigilator, would leave his/her seat.
10. Use of Electronic/Manual Calculator is prohibited.
11. The candidates are governed by all Rules and Regulations of the examination with regard to their conduct in the Examination Hall. All cases of unfair means will be dealt with as per Rules and Regulations of this examination.
12. No part of the **Test Booklet** and **Answer Sheet** shall be detached under any circumstances.
13. The candidates will write the Correct Test Booklet Code as given in the Test Booklet / Answer Sheet in the Attendance Sheet.

PHYSICS

1. For a simple pendulum, having time period T , the variation of kinetic energy (K.E.) with time (t) is represented by:

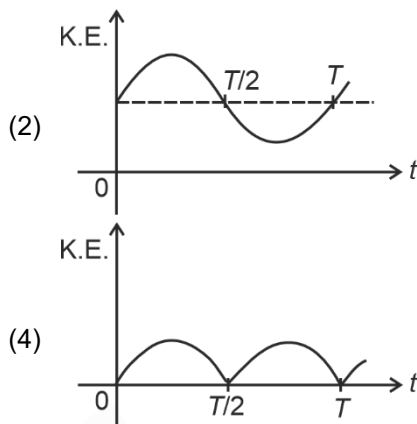
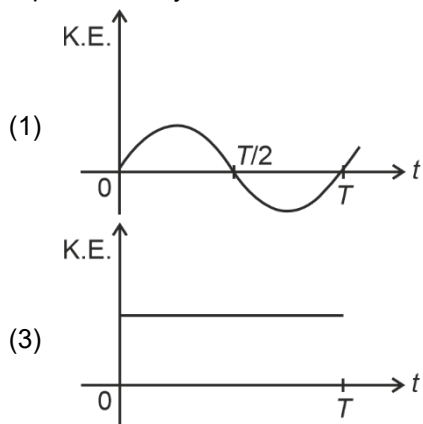

Answer (4)

2. A room heater is rated 400 W, 220 V. If the supply voltage drops to 200 V, what will be the power consumed (approximately)?

- (1) 400 W (2) 121 W
(3) 331 W (4) 200 W

Answer (3)

3. The angular speed of a flywheel is increased from 600 rpm to 1200 rpm in 10 s. The number of revolutions completed by the flywheel during this time is :

- (1) 600 (2) 300
(3) 900 (4) 150

Answer (4)

4. The sum of kinetic energy and potential energy of a simple pendulum bob is 0.02 joule. The speed of the simple pendulum bob at equilibrium position is approximately:

(Consider mass of the bob = 20 g)

- (1) 2.0 m/s (2) 0.2 m/s
(3) 14.1 m/s (4) 1.41 m/s

Answer (4)

5. A 100-turn closely wound circular coil of radius 5 cm has a magnetic field of 3.14×10^{-3} T at its centre. The current flowing through the coil, and the magnitude of the magnetic moment of this coil are, respectively :

(Take $\mu_0 = 4\pi \times 10^{-7}$ T m/A)

- (1) 2.5 A, 20 A m² (2) 2 A, 4 A m²
(3) 2.5 A, 2 A m² (4) 2 A, 10 A m²

Answer (3)

6. A submarine is designed to withstand an absolute pressure of 100 atm. How deep can it go below the water surface?

(Consider the density of water = 1000 kg m⁻³,
1 atm = 1×10^5 Pa and gravitational acceleration $g = 10$ m/s²)

- (1) 9900 m (2) 990 m
(3) 9000 m (4) 99 m

Answer (2)

10. The amount of work done to raise a mass 'm' from the surface of the Earth to a height equal to the radius of the Earth 'R' will be

- (1) $mg \frac{R}{2}$ (2) mgR
(3) $mg \frac{R}{4}$ (4) $2 mg R$

Answer (1)

11. When a ruler falls vertically, 5 different persons catch it with different reaction times.

($g = 9.8 \text{ m s}^{-2}$)

- A. Person A has reaction time of 0.20 s.
B. Person B has reaction time of 0.22 s.
C. Person C has reaction time of 0.18 s.
D. Person D has reaction time of 0.19 s.
E. Person E has reaction time of 0.21 s.

What is the **correct** order of the distance travelled by the ruler for each person?

- (1) $B > E > A > C > D$
(2) $C > D > A > E > B$
(3) $C > D > A > B > E$
(4) $B > E > A > D > C$

Answer (4)

12. The power of a crane, which lifts a mass of 1000 kg to a height of 20 m in 10 s is: ($g = 9.8 \text{ m/s}^2$)

- (1) 19.6 kW (2) 19.6 W
(3) 39.2 kW (4) 39.2 W

Answer (1)

13. Consider two uncharged capacitors of equal capacitance 200 pF. One of them is charged by a 100 V supply and disconnected. Now this capacitor is connected to the uncharged capacitor. The amount of electrostatic energy lost in the process is:

- (1) 0.5 J (2) $1.0 \times 10^{-6} \text{ J}$
(3) $0.5 \times 10^{-6} \text{ J}$ (4) 1.0 J

Answer (3)

14. An ac circuit contains a resistance of 1 k Ω , a capacitor of 0.1 μF and an inductor of 1 mH connected in series. The resonance frequency of the circuit is approximately:

- (1) 15.9 kHz (2) 20.7 kHz
(3) 10.1 kHz (4) 13.5 kHz

Answer (1)

15. The figure given below shows a long straight solid wire of circular cross-section of radius 'a' carrying steady current I . The current I is uniformly distributed across its cross-section. The plot which correctly represents the variation of magnetic field (B) with distance (r) from the axis of the conductor in the region is :

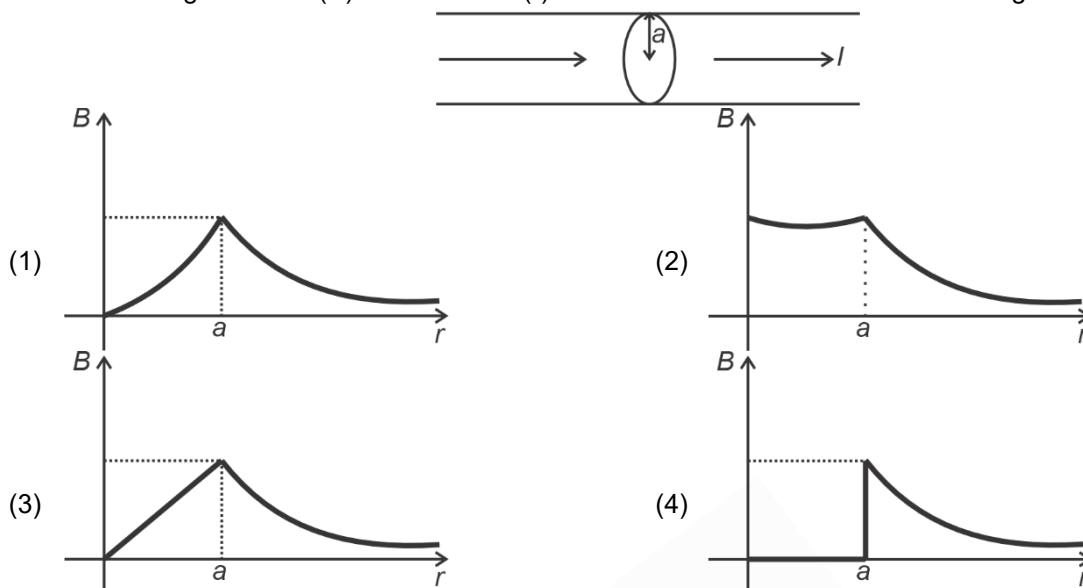

Answer (3)

16. An electric heater supplies heat to a system at a rate of 100 W. If the system performs work at a rate of 75 J/s, then the rate at which internal energy increases will be:

- (1) 75 W (2) 25 W
(3) 100 W (4) 125 W

Answer (2)

17. The peak value of an alternating current is 5 A and frequency is 60 Hz. How long will the current, starting from zero, take to reach the peak value ?

- (1) $\frac{1}{120}$ s (2) $\frac{1}{240}$ s
(3) $\frac{1}{30}$ s (4) $\frac{1}{60}$ s

Answer (2)

18. In Young's double slit experiment, using monochromatic light of wavelength λ , the intensity of light at a point on the screen where the path difference is λ , is K units. The intensity of light at a point where the path difference is $\frac{\lambda}{3}$ will be

- (1) K (2) $2K$
(3) $\frac{K}{2}$ (4) $\frac{K}{4}$

Answer (4)

19. Four statements are given (A is mass number):

- A. The volume of a nucleus is proportional to $A^{1/3}$.
B. The volume of a nucleus is proportional to A .
C. The difference in mass of an atom and its nucleus is called the mass defect.
D. The difference in mass of a nucleus and its constituents is called the mass defect.

Choose the **correct** answer from the options given below:

- (1) A and D are true, but B and C are false (2) B and D are true, but A and C are false
(3) B and C are true, but A and D are false (4) A and C are true, but B and D are false

Answer (2)

25. Two statements are given below:
- A. When the forward bias voltage across a p-n junction diode increases above a certain threshold voltage, the diode current increases significantly.
- B. This current is called reverse saturation current.

Choose the **correct** answer from the options given below:

- (1) Both Statements A and B are true
 (2) Both Statements A and B are false
 (3) Statement A is true, but Statement B is false
 (4) Statement A is false, but Statement B is true

Answer (3)

26. In a concave lens, a ray of light emanating from the object parallel to the principal axis of the lens after refraction:
- (1) passes through the second principal focus.
 (2) appears to diverge from the first principal focus.
 (3) passes through $2F$, which is the radius of curvature of the lens.
 (4) emerges parallel to the principal axis.

Answer (2*)

27. An unknown nucleus has a nuclear density of $2.29 \times 10^{17} \text{ kg/m}^3$ and mass of $19.926 \times 10^{-27} \text{ kg}$. Its mass number A is approximately:

(Take $R_0 = 1.2 \times 10^{-15} \text{ m}$, $4\pi = 12.56$)

- (1) 16 (2) 20
 (3) 12 (4) 19

Answer (3)

28. A galvanometer of resistance 100Ω gives full scale deflection for a current of 1 mA . It is converted into an ammeter of range $0 - 10 \text{ A}$. The shunt required is:

- (1) 0.001Ω (2) 0.10Ω
 (3) 1.0Ω (4) 0.01Ω

Answer (4)

29. A thin wire of length ' L ' and linear mass density ' m ' is bent into a circular ring (in x-y plane) with centre ' C ' as shown in figure. The moment of inertia of the ring about an axis yy' will be :

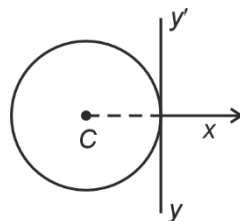

- (1) $\frac{3mL^3}{8\pi}$ (2) $\frac{3mL^2}{8\pi^2}$
 (3) $\frac{3mL^3}{8\pi^2}$ (4) $\frac{3mL^2}{8\pi}$

Answer (3)

30. For a travelling harmonic wave

$y(x, t) = 2.0 \cos 2\pi(10t - 0.0080x + 0.35)$, where x and y are in cm and t in s. The phase difference between oscillatory motion of two points separated by a distance of 0.5 m is:

- (1) 0.08π rad
- (2) 0.008π rad
- (3) 0.8π rad
- (4) 8π rad

Answer (3)

31. A box of mass 15 kg is kept on the floor of a stationary trolley. The coefficient of static friction between the box and the trolley is 0.12. Keeping the box in stationary state over the trolley, the maximum acceleration with which the trolley can be moved horizontally in m s^{-2} is:

($g = 10 \text{ m/s}^2$)

- (1) 1.8
- (2) 1.2
- (3) 1.5
- (4) 2.1

Answer (2)

32. In the circuit shown below, the voltage appearing across the diode D will be of the form:

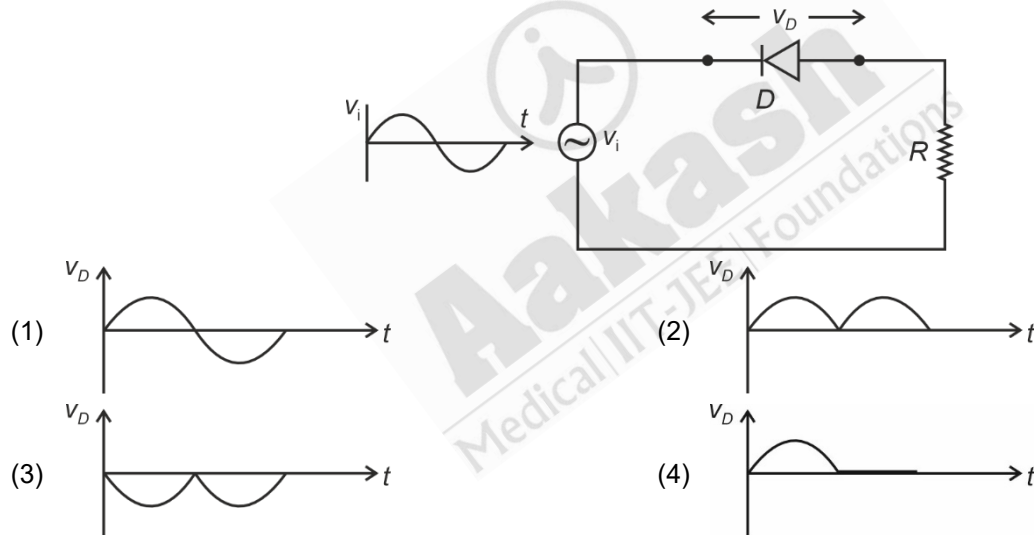

Answer (4)

33. A flask contains argon and chlorine in the ratio of 2 : 1 by mass. The temperature of the mixture is 27°C . The ratio of root mean square speed of the molecules of the two gases $\left(\frac{V_{\text{rms}}^{\text{Ar}}}{V_{\text{rms}}^{\text{Cl}}}\right)$ is:

(Atomic mass of argon = 40.0 u and molecular mass of chlorine = 70.0 u)

- (1) $\frac{7}{4}$
- (2) $\frac{2}{\sqrt{7}}$
- (3) $\frac{\sqrt{7}}{2}$
- (4) $\frac{7}{2}$

Answer (3)

34. Match List I with List II:

	List-I (Electromagnetic wave)		List-II (Production)
A.	Microwave	I.	Electrons in atoms emit light when they move from a higher energy level to a lower energy level
B.	Visible light	II.	Radioactive decay of nucleus
C.	Gamma rays	III.	Vibration of atoms and molecules
D.	Infra-red rays	IV.	Klystron valve or magnetron valve

Choose the **correct** answer from the options given below:

- (1) A–IV, B–III, C–II, D–I
 (2) A–III, B–IV, C–I, D–II
 (3) A–III, B–I, C–II, D–IV
 (4) A–IV, B–I, C–II, D–III

Answer (4)

35. The magnitude and direction of the acceleration produced in a body of mass 5 kg when two mutually perpendicular forces 8 N and 6 N act on it, are respectively:

- (1) 2 m s^{-2} ; $\tan^{-1} (3/4)$ with 8 N force (2) 2 m s^{-2} ; $\tan^{-1} (4/3)$ with 8 N force
 (3) 2 m s^{-2} ; $\tan^{-1} (3/4)$ with 6 N force (4) 20 m s^{-2} ; $\tan^{-1} (4/3)$ with 8 N force

Answer (1)

36. The current I in the circuit shown below is:

(All diodes are ideal and identical)

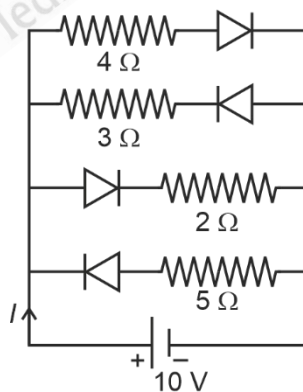

- (1) $\frac{1}{3} \text{ A}$ (2) $\frac{15}{2} \text{ A}$
 (3) $\frac{5}{3} \text{ A}$ (4) $\frac{5}{9} \text{ A}$

Answer (2)

37. For a metal of work function 6.6 eV, which of the following wavelengths of incident radiation does **not** give rise to the photoelectric effect?

(Take Planck's constant as 6.6×10^{-34} J s)

- (1) 200 nm (2) 100 nm
(3) 50 nm (4) 150 nm

Answer (1)

38. The speed of light in vacuum is taken as unity. If light takes 6 min 40 s to reach the Earth from the Sun, the distance between the Sun and the Earth in new unit is:

- (1) 3×10^8 (2) 500
(3) 3×10^{10} (4) 400

Answer (4)

39. A rectangular wire loop of sides 8 cm and 3 cm with a small cut, is moving out of a region of uniform magnetic field of magnitude 0.3 T directed normal to the plane of the loop. The emf developed across the cut, if the velocity of the loop is 2 cm s^{-1} , in a direction normal to the shorter side of the loop, will be :

- (1) 1.8×10^{-4} volt (2) 1.3×10^{-4} volt
(3) 1.2×10^{-4} volt (4) 4.8×10^{-4} volt

Answer (1)

40. The following plots show variation of velocity (v) with time (t) of a ball thrown vertically upward, and falling back. Which of the following plots is/are correct?

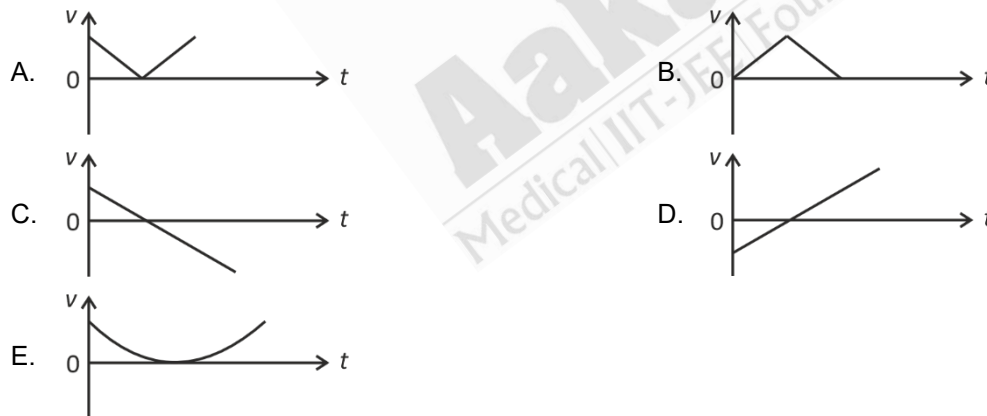

- (1) B only (2) A and E only
(3) C only (4) D only

Answer (3)

41. In a vernier calliper, 20 VSD coincide with 16 MSD (each division of length 1 mm). The least count of the vernier callipers is:

- (1) 0.2 cm (2) 0.1 cm
(3) 0.02 cm (4) 0.01 cm

Answer (3)

42. Each side of a metallic cube of mass 5.580 kg is measured to the 9.0 cm. Keeping the significant figures in view, the density of the material of the cube can be best expressed as $X \times 10^3 \text{ kg m}^{-3}$ where the value of X is:
- (1) 7.654 (2) 7.7
(3) 7.65 (4) 7.6

Answer (2)

43. A ray of monochromatic light is passing through an equilateral prism (ABC) as shown in the figure. The refracted ray (QR) is parallel to its base (BC) and the angle of incidence (i) is 50° . Then the angle of deviation (δ) is:

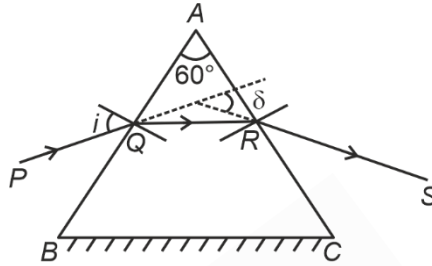

- (1) 45° (2) 55°
(3) 35° (4) 40°

Answer (4)

44. In the first excited state of hydrogen atom, the energy of its electron is -3.4 eV . The radial distance of the electron from the hydrogen nucleus in this case is approximately:

(Take $1 \text{ eV} = 1.6 \times 10^{-19} \text{ J}$, $e = 1.6 \times 10^{-19} \text{ C}$ and $\frac{1}{4\pi\epsilon_0} = 9 \times 10^9 \text{ N m}^2/\text{C}^2$)

- (1) $2.1 \times 10^{-8} \text{ m}$ (2) $2.1 \times 10^{-10} \text{ m}$
(3) $2.1 \times 10^{-11} \text{ m}$ (4) $2.1 \times 10^{-9} \text{ m}$

Answer (2)

45. A uniform metallic wire having resistance 4Ω is bent to form a square loop ($ABCD$) (see figure). A resistance of 2Ω is connected between points B and D and a battery of 2 V is connected across points A and C as shown in the figure. Now the value of current (I) is :

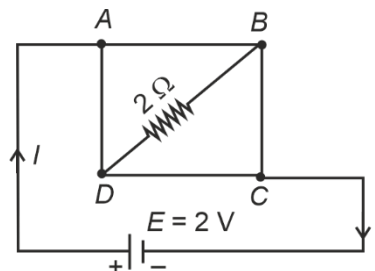

- (1) 4 A (2) 4.5 A
(3) 8 A (4) 2 A

Answer (4)

CHEMISTRY

46. Match List I with List II :

	List I (Complex/ion)		List II (Shape/geometry)
A.	[Pt(Cl ₂)(NH ₃) ₂]	(I)	Octahedral
B.	[Co(NH ₃) ₆]Cl ₃	(II)	Trigonal bipyramidal
C.	[NiCl ₄] ²⁻	(III)	Square planar
D.	[Fe(CO) ₅]	(IV)	Tetrahedral

Choose the **correct** answer from the options given below :

- (1) A-I, B-III, C-IV, D-II
- (2) A-III, B-IV, C-I, D-II
- (3) A-III, B-I, C-IV, D-II
- (4) A-IV, B-I, C-III, D-II

Answer (3)

47. Calculate emf of the half cell given below :

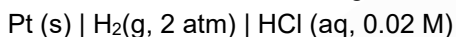

$$E_{\text{H}_2/\text{H}^+}^\circ = 0 \text{ V}$$

(Given: $\frac{2.303 RT}{F} = 0.059$, $\log 2 = 0.3010$)

- (1) -0.109 V
- (2) 0.109 V
- (3) 0.035 V
- (4) -0.035 V

Answer (2)

48. At 298 K, a certain buffer solution contains equal concentrations of X⁻ and HX, K_b for X⁻ is 10⁻¹⁰. What is the pH of this buffer solution?

- | | |
|--------|-------|
| (1) 10 | (2) 4 |
| (3) 2 | (4) 6 |

Answer (2)

49. Given below are certain reactions. Identify the reaction for which K_P ≠ K_C.

- (1) N₂(g) + O₂(g) ⇌ 2NO(g)
- (2) H₂O(g) + CO(g) ⇌ H₂(g) + CO₂(g)
- (3) N₂(g) + 3H₂(g) ⇌ 2NH₃(g)
- (4) H₂(g) + I₂(g) ⇌ 2HI(g)

Answer (3)

50. For a certain reaction $R \rightarrow \text{Product}$, the plot of concentration $[R]$ vs time has a negative slope as shown. The order of reaction is :

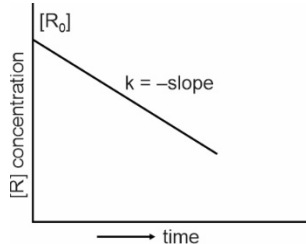

- (1) 1 (2) 2.5
 (3) 2 (4) 0

Answer (4)

51. Consider the following reaction :

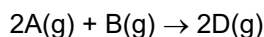

$$\Delta U^\ominus = -10 \text{ kJ mol}^{-1} \text{ and } \Delta S^\ominus = -44 \text{ JK}^{-1} \text{ at } 298 \text{ K.}$$

Identify the **correct** option with ΔG^\ominus for the reaction and spontaneity of the reaction at 298 K.

(Given : $R = 8.31 \text{ J mol}^{-1} \text{ K}^{-1}$)

- (1) $+0.63568 \text{ kJ mol}^{-1}$, non-spontaneous
 (2) $-0.63568 \text{ kJ mol}^{-1}$, spontaneous
 (3) $-1.635 \text{ kJ mol}^{-1}$, spontaneous
 (4) $+1.635 \text{ kJ mol}^{-1}$, non-spontaneous

Answer (1)

52. Given below is an expression for the rate constant of a first-order reaction occurring at a certain temperature, T (K).

$$\ln k = 14.34 - \frac{1.25 \times 10^4}{T}$$

The energy of activation in kcal mol^{-1} for the reaction is :

(Given: k in s^{-1} , $R = 1.987 \text{ cal mol}^{-1} \text{ K}^{-1}$)

- (1) 12.42 (2) 18.63
 (3) 14.34 (4) 24.84

Answer (4)

53. Select the reagents that reduce nitriles to primary amines.

- A. (i) LiAlH_4 ; (ii) H_2O
 B. $\text{Sn} + \text{HCl}$
 C. H_2/Ni
 D. $\text{Na}(\text{Hg})/\text{C}_2\text{H}_5\text{OH}$
 E. $\text{Br}_2/\text{aq. NaOH}$

Choose the **correct** answer from the options given below.

- (1) A, B and C only (2) A, D and E only
 (3) A, C and D only (4) B, D and E only

Answer (3)

54. The correct statement with regard to the secondary structure of DNA/RNA is
- (1) DNA possesses a double strand helix structure and contains thymine as one of the four bases
 - (2) DNA possesses a single strand helix structure and contains uracil as one of the four bases
 - (3) RNA possesses a double strand helix structure and contains uracil as one of the four bases
 - (4) RNA possesses a single strand helix structure and contains thymine as one of the four bases

Answer (1)

55. During Lassaigne's test, the elements present in an organic compound are converted from :
- (1) Ionic form to ionic form
 - (2) Covalent form to ionic form
 - (3) Ionic form to covalent form
 - (4) Covalent form to covalent form

Answer (2)

56. Mixture of chloroform and acetone forms a solution with negative deviation from Raoult's law due to :
- (1) Stronger intermolecular forces between chloroform molecules than those between chloroform and acetone molecules.
 - (2) Formation of hydrogen bonding between acetone and chloroform
 - (3) Repulsive forces.
 - (4) Increase in escaping tendency of molecules of each component.

Answer (2)

57. In a test tube containing a salt, a few drops of dilute H_2SO_4 was added, which gave colourless vapours having the smell of vinegar. The vapours turned the blue litmus paper red. Identify the **correct** anion from the following :

- | | |
|--|----------------------------------|
| (1) Carbonate, CO_3^{2-} | (2) Sulphide, S^{2-} |
| (3) Acetate, CH_3COO^- | (4) Sulphate, SO_4^{2-} |

Answer (3)

58. Identify the correct statement about ClF_3 from the following options :
- (1) It has T-shaped geometry with three lone pairs on Cl atom.
 - (2) It has T-shaped geometry with two lone pairs on Cl atom.
 - (3) It has a trigonal pyramidal geometry with two lone pairs on Cl atom.
 - (4) It has a planar trigonal geometry with two lone pairs on Cl atom.

Answer (2)

63. Compound P (C_8H_8O) gives a red orange precipitate with 2,4-DNP reagent and it does not reduce Fehling's reagent. On drastic oxidation with chromic acid, P gives an aromatic product Q that produces effervescence on treating with aq. $NaHCO_3$. Compounds P and Q, respectively, are :

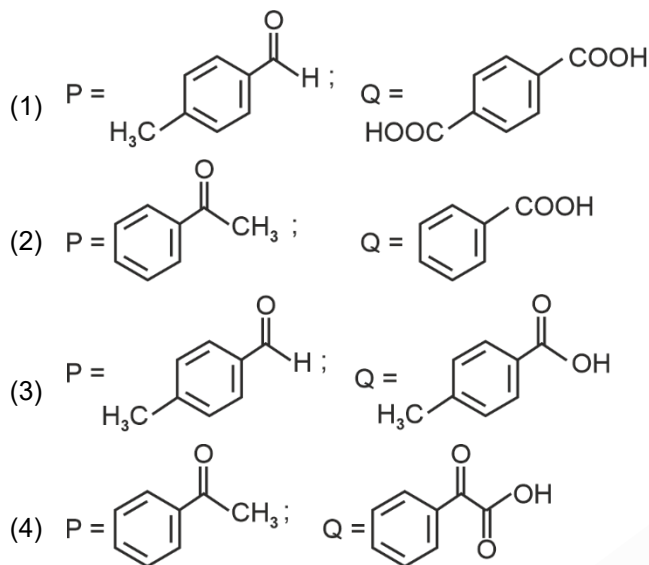

Answer (2 or 3)

64. The correct IUPAC name of the following compound is :

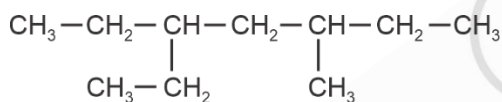

- (1) 3-ethyl-5-methylheptane
(2) 3-methyl-5-ethylheptane
(3) 2,4-diethylhexane
(4) 3,5-diethylhexane

Answer (1)

65. In the following reaction sequence, X and Z respectively are :

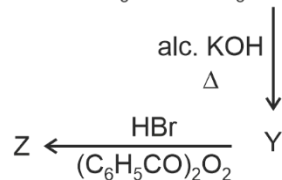

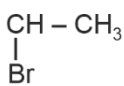
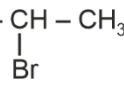
- (1) X = $POCl_3$; Z = 
- (2) X = $POCl_3$; Z = $CH_3CH_2CH_2 - Br$
- (3) X = H_3PO_3 ; Z = 
- (4) X = H_3PO_3 ; Z = $CH_3CH_2CH_2 - Br$

Answer (2)

66. When 1 dm³ of CO₂ gas is passed over hot coke, the volume of gaseous mixture after complete reaction at STP becomes 1.4 dm³. The composition of the gaseous mixture at STP is:
- (1) 0.6 dm³ of CO, 0.8 dm³ of CO₂
 - (2) 0.8 dm³ of CO, 0.8 dm³ of CO₂
 - (3) 0.6 dm³ of CO, 0.4 dm³ of CO₂
 - (4) 0.8 dm³ of CO, 0.6 dm³ of CO₂

Answer (4)

67. The correct formal charges on oxygen atoms numbered 2, 1 and 3 respectively are :

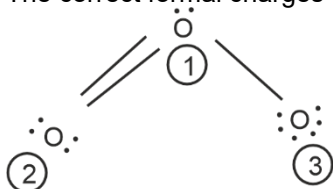

- (1) 0, 0, 0
- (2) -1, 0, +1
- (3) +1, 0, -1
- (4) 0, +1, -1

Answer (4)

68. Match List I with List II :

	List-I (Order of reaction)		List-II (Unit of rate constant)
A.	Zero order	I.	mol ⁻¹ L s ⁻¹
B.	First order	II.	mol ⁻² L ² s ⁻¹
C.	Second order	III.	s ⁻¹
D.	Third order	IV.	mol L ⁻¹ s ⁻¹

Choose the **correct** answer from the options given below :

- (1) A-IV, B-III, C-II, D-I
- (2) A-IV, B-III, C-I, D-II
- (3) A-I, B-II, C-III, D-IV
- (4) A-IV, B-II, C-I, D-III

Answer (2)

69. The correct order of increasing metallic character of Na, Be, P, Mg and Si is
- (1) Be < Si < P < Mg < Na
 - (2) P < Si < Na < Mg < Be
 - (3) P < Si < Be < Mg < Na
 - (4) P < Mg < Be < Si < Na

Answer (3)

70. The number of hydrogen atoms present in 5.4 g of urea is:

(Given: Molar mass of urea : 60 g mol⁻¹,

N_A : 6.022 × 10²³ particles mol⁻¹)

- (1) 2.168 × 10²²
- (2) 2.168 × 10²³
- (3) 1.084 × 10²²
- (4) 1.084 × 10²³

Answer (2)

71. In a qualitative analysis, Bi^{3+} is detected by appearance of precipitate of BiO(OH)(s) . Calculate pH when the following equilibrium exists at 298 K.

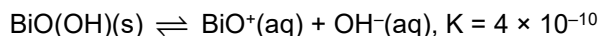

(Given : $\log 2 = 0.3010$)

- (1) 4.699 (2) 5.286
(3) 8.714 (4) 9.301

Answer (4)

72. Match List I with List II:

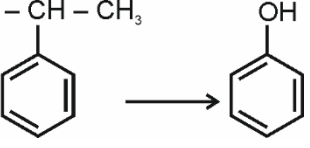
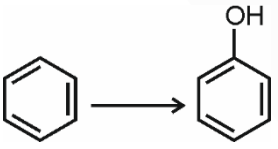
	List I		List II
A.	$\text{H}_3\text{C}-\text{CH}-\text{CH}_3$ 	(I)	(i) Oleum; (ii) NaOH, Δ ; (iii) H^+
B.	$\text{CH}_3\text{COOH} \longrightarrow \text{CH}_3\text{CH}_2\text{OH}$	(II)	(i) O_2 ; (ii) $\text{H}_2\text{O}/\text{H}^+$
C.	$\text{CH}_3\text{CH}_2\text{CH}_2\text{OH} \longrightarrow$ $\text{CH}_3-\text{CH}-\text{CH}_3$ $\quad \quad \quad $ $\quad \quad \quad \text{OH}$	(III)	(i) $\text{CH}_3\text{OH}, \text{H}^+$; (ii) H_2 , catalyst
D		(IV)	(i) conc. $\text{H}_2\text{SO}_4, \Delta$; (ii) $\text{H}^+/\text{H}_2\text{O}$

Choose the **correct** answer from the options given below :

- (1) A-I, B-III, C-IV, D-II
(2) A-II, B-IV, C-III, D-I
(3) A-II, B-III, C-IV, D-I
(4) A-II, B-III, C-I, D-IV

Answer (3)

73. A bulb is rated at 150 watt, converting 8% energy into light. If energy of one photon is 4.42×10^{-19} J, how many photons are emitted by the bulb per second?

- (1) 27.2×10^{19}
(2) 4.06×10^{19}
(3) 1.35×10^{19}
(4) 2.71×10^{19}

Answer (4)

74. The pair of molecules that are metamers among the following is :

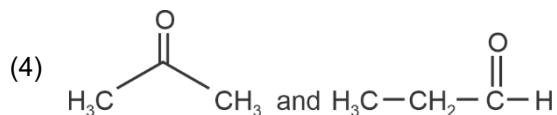
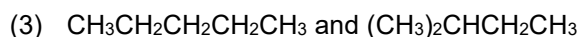

Answer (1)

75. Identify the correct statements :

- (A) The molality of 2.5 g of ethanoic acid (Molar mass : 60 g mol^{-1}) in 75 g of benzene solution is 0.556 m.
 (B) The molarity of a solution containing 5 g of NaOH (molar mass : 40 g mol^{-1}) in 450 mL of solution is 0.278 M at 298 K.
 (C) Aquatic species are more comfortable in cold water.
 (D) The solubility of gas increases with decrease in pressure.
 (E) For a binary mixture of A and B, the number of moles of A and B are n_A and n_B respectively. The mole

fraction of B will be $x_B = \frac{n_A}{n_A + n_B}$.

Choose the **correct** answer from the options given below :

- (1) A, B and C only (2) A, D and E only
 (3) A and B only (4) A and C only

Answer (1)

76. Which one of the following is an ambidentate ligand?

- (1) Oxalate (2) Ethane-1,2-diamine
 (3) Thiocyanate (4) Ethylenediaminetetracetate ion

Answer (3)

77. The functional group that can be identified through phthalein dye test is :

- (1) Carboxylic acid (2) Alcohol
 (3) Aldehyde (4) Phenolic

Answer (4)

78. Match List I with List II :

	List I		List II
A.	C_2H_4	I.	3 σ bonds, 2 π bonds
B.	C_2H_2	II.	3 σ bonds, one lone pair
C.	CH_4	III.	4 σ bonds
D.	NH_3	IV.	5 σ bonds, 1 π bond

Choose the **correct** answer from the options given below :

- (1) A-IV, B-I, C-III, D-II (2) A-III, B-IV, C-II, D-I
 (3) A-II, B-III, C-I, D-IV (4) A-I, B-II, C-IV, D-III

Answer (1)

79. A solution of copper sulphate is electrolysed for 10 minutes with a current of 1.5 amperes. The mass of copper deposited at cathode is :

(Given : Molar mass of Cu = 63 g mol⁻¹;

1 F = 96487 C mol⁻¹)

- (1) 0.2938 g (2) 0.5876 g
(3) 2.4036 g (4) 1.7018 g

Answer (1)

80. Match List I with List II :

	List I (Quantum Numbers)			List II (Orbital)
	'n'	'l'		
A.	2	1	I.	3d
B.	4	0	II.	2p
C.	5	3	III.	4s
D.	3	2	IV.	5f

Choose the **correct** answer from the options given below.

- (1) A-II, B-III, C-IV, D-I
(2) A-I, B-II, C-III, D-IV
(3) A-II, B-III, C-I, D-IV
(4) A-IV, B-II, C-III, D-I

Answer (1)

81. The major product Z formed in the following sequence of reactions is

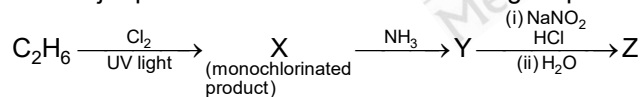

- (1) C₂H₅ – N = N – OH
(2) C₂H₅OH
(3) C₂H₅NO₂
(4) C₂H₅NH₂

Answer (2)

82. Although +3 oxidation state is most common in lanthanoids, cerium still shows +4 oxidation state because:

- (1) After losing one more electron, it acquires 4f¹⁴ electronic configuration.
(2) Its nearest inert gas is Radon.
(3) After losing one more electron, it acquires 4f⁰ electronic configuration.
(4) Its atomic number is 61.

Answer (3)

83. Methane reacts with steam at 1273 K in the presence of nickel catalyst to form :

- (1) CO and H₂
- (2) CO and H₂O
- (3) CO₂ and H₂
- (4) CO₂ and H₂O

Answer (1)

84. Identify the **incorrect** statement from the following:

- (1) Oxygen exhibits only –2 oxidation state.
- (2) The order of catenation property of Group 14 elements is C >> Si > Ge ≈ Sn.
- (3) Carbon has the ability to form pπ-pπ multiple bond with itself.
- (4) ECl₃ (E = B and Al) is a monomer when E = B and a dimer when E = Al.

Answer (1)

85. Phenolphthalein is used as an indicator for the titration of sodium hydroxide solution against a standard solution of oxalic acid. The colour change that is observed at an alkaline pH close to the equivalence point during this titration is:

- (1) Pink to colourless
- (2) Pinkish red to yellow
- (3) Colourless to pink
- (4) Yellow to pinkish red

Answer (3)

86. Identify the **incorrect** statement from the following :

- (1) The largest and the smallest species among Mg, Mg²⁺, Al and Al³⁺ are Al and Mg²⁺ respectively.
- (2) The IUPAC name of the element with atomic number 107 is Unnilseptium.
- (3) The similarity in behaviour of Li with Mg is referred to as 'diagonal relationship'
- (4) The oxidation state and covalency of Al in [AlCl(H₂O)₅]²⁺ are 3 and 6 respectively.

Answer (1)

87. The following two reactions give the same foul smelling product Z.

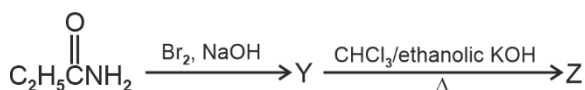
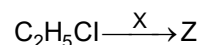

X and Z, respectively, are :

- | | |
|--|--|
| (1) X = AgCN; Z = C ₂ H ₅ CN | (2) X = AgCN; Z = C ₂ H ₅ NC |
| (3) X = KCN; Z = C ₂ H ₅ CN | (4) X = KCN; Z = C ₂ H ₅ NC |

Answer (2)

88. The calculated 'spin-only' magnetic moment of Ti^{2+} ($3d^2$) is :

- (1) 3.87 BM
- (2) 4.90 BM
- (3) 2.84 BM
- (4) 5.92 BM

Answer (3)

89. Match List I with List II :

	List I (Transition metal/compound/ complex)		List II (Catalytic Role)
A.	V_2O_5	I.	Preparation of ammonia from N_2/H_2 mixture
B.	Fe	II.	Polymerisation of alkynes
C.	$PdCl_2$	III.	Preparation of H_2SO_4 and SO_2
D.	Ni complex	IV.	Oxidation of ethyne to ethanal

Choose the **correct** answer from the options given below.

- (1) A-III, B-IV, C-I, D-II
- (2) A-III, B-I, C-IV, D-II
- (3) A-II, B-I, C-IV, D-III
- (4) A-IV, B-I, C-III, D-II

Answer (2)

90. Two products X and Y are formed in the following reaction sequence.

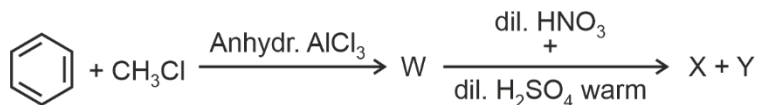

The suitable method that can be used for the separation of products X and Y is :

- (1) Continuous extraction
- (2) Differential extraction
- (3) Sublimation
- (4) Fractional distillation

Answer (4)

BIOLOGY

91. Match List I with List II:

	List-I		List-II
A.	Genetically modified organism	(I)	<i>Agrobacterium tumefaciens</i>
B.	Thermostable DNA polymerase	(II)	Bt cotton
C.	Ti plasmid	(III)	<i>Thermus aquaticus</i>
D.	pBR322	(IV)	<i>Escherichia coli</i>

Choose the **correct** answer from the options given below:

- (1) A-II, B-I, C-IV, D-III
- (2) A-II, B-III, C-I, D-IV
- (3) A-I, B-IV, C-III, D-II
- (4) A-I, B-II, C-IV, D-III

Answer (2)

92. Exploring molecular, genetic and species-level diversity for products of economic importance is called

- (1) Bioprospecting
- (2) Biofortification
- (3) Biomagnification
- (4) Bioremediation

Answer (1)

93. Which of the following statements are true with reference to the sex-determination in honeybees?

- A. An offspring formed from the union of a sperm and an egg, develops as a female (queen or worker).
- B. An unfertilized egg develops as a male by parthenogenesis.
- C. A male has half the number of chromosomes than that of a female.
- D. Males produce sperms by meiosis.
- E. Honeybees have a haplodiploid sex-determination system.

Choose the **correct** answer from the options given below :

- (1) A, B, C and E only
- (2) A, B, C and D only
- (3) B, C, D and E only
- (4) A, B, D and E only

Answer (1)

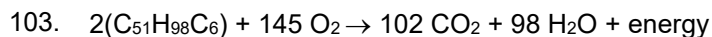

The Respiratory Quotient (RQ) of a biomolecule used for respiration, as per the above equation would be :

- (1) Less than 0.5 (2) Between 1.25 and 2
(3) 1.0 (4) Between 0.5 and 0.95

Answer (4)

104. Which one of the following is **not** a characteristic of plant cells in the phase of elongation?

- (1) New cell wall deposition (2) Cell enlargement
(3) Large conspicuous nuclei (4) Increased vacuolation

Answer (3)

105. Arrange the following steps of somatic hybridisation in a correct sequence.

- A. Digestion of cell walls.
B. Isolation of naked protoplasts.
C. Fusion of protoplasts to get hybrid protoplast.
D. Isolation of single cells from two different varieties of plants.
E. Growing of hybrid protoplast to form a new plant.

Choose the **correct** answer from the options given below:

- (1) D, B, A, E, C (2) E, A, B, C, D
(3) E, B, A, D, C (4) D, A, B, C, E

Answer (4)

106. Match List-I with List-II :

	List-I		List-II
A.	Conjunctive tissue	I.	Specialised cells in the vicinity of guard cells
B.	Casparian strips	II.	Endodermal cells rich in starch
C.	Subsidiary cells	III.	Tissue between xylem and phloem
D.	Starch sheath	IV.	Endodermal cells with suberin deposition

Choose the **correct** answer from the options given below :

- (1) A-IV, B-III, C-II, D-I
(2) A-III, B-IV, C-I, D-II
(3) A-IV, B-III, C-I, D-II
(4) A-III, B-IV, C-II, D-I

Answer (2)

112. "The Evil Quartet" of biodiversity loss includes which of the following?
- (1) Over-exploitation; Alien species invasions; Soil pollution; Co-extinctions
 - (2) Habitat loss and fragmentation; Air pollution; Water pollution; Co-extinctions
 - (3) Habitat loss and fragmentation; over-exploitation; Alien species invasions; Co-extinctions
 - (4) Over-exploitation; Alien species invasions; Air pollution; Co-extinctions

Answer (3)

113. Arrange the following steps of DNA fingerprinting in a correct sequence.
- A. Isolation of DNA and its digestion by restriction endonucleases.
 - B. Hybridisation using a labelled VNTR probe.
 - C. Transferring of separated DNA fragments to synthetic membranes.
 - D. Detection of hybridised DNA fragments by autoradiography.
 - E. Separation of DNA fragments by electrophoresis.

Choose the **correct** answer from the options given below :

- (1) A, E, B, C, D
- (2) A, D, B, E, C
- (3) A, B, D, C, E
- (4) A, E, C, B, D

Answer (4)

114. Which of the following statements are correct with reference to a transcription unit?
- A. A transcription unit in DNA is defined primarily by three regions : promoter, structural gene and terminator.
 - B. The promoter is said to be located towards the 5'-end of the structural gene.
 - C. The promoter is a DNA sequence that provides binding site for RNA polymerase.
 - D. The promoter defines the template and coding strands.
 - E. The terminator is located towards the 3'-end of the coding strand and it defines the end of the process of transcription.

Choose the **correct** answer from the options given below:

- (1) B, C, D and E only
- (2) A, B, C, D and E
- (3) A, B, C and D only
- (4) A, C, D and E only

Answer (2)

115. Which one of the following types of pollination brings genetically different types of pollen grains to the stigma?
- | | |
|-----------------|--------------|
| (1) Geitonogamy | (2) Xenogamy |
| (3) Cleistogamy | (4) Autogamy |

Answer (2)

116. Which of the following is an *in situ* conservation method?

- (1) Seed Banks
- (2) Sacred Groves
- (3) Botanical Gardens
- (4) Wildlife Safari Parks

Answer (2)

117. Heterophyllous development in response to environment is an example of which of the following phenomena?

- | | |
|-----------------------|-----------------------|
| (1) Redifferentiation | (2) Dedifferentiation |
| (3) Elasticity | (4) Plasticity |

Answer (4)

118. Match List I with List II :

	List I		List II
A.	Productivity	I.	Gross primary productivity minus respiration losses
B.	Net primary productivity	II.	Rate of formation of new organic matter by consumers
C.	Gross primary productivity	III.	Rate of biomass production
D.	Secondary productivity	IV.	Rate of production of organic matter during photosynthesis

Choose the **correct** answer from the options given below :

- (1) A-III, B-I, C-II, D-IV
- (2) A-I, B-II, C-III, D-IV
- (3) A-III, B-I, C-IV, D-II
- (4) A-I, B-III, C-IV, D-II

Answer (3)

119. Which of the following statements are correct regarding amino acids?

- A. They are substituted methanes.
- B. Serine is an aromatic amino acid.
- C. Valine is a neutral amino acid.
- D. Lysine is an acidic amino acid.

Choose the **correct** answer from the options given below:

- | | |
|------------------|------------------|
| (1) A and B only | (2) C and D only |
| (3) B and C only | (4) A and C only |

Answer (4)

120. In which one of the following, the ovules are **not** enclosed by an ovary wall and remain exposed?

- (1) *Pinus*
- (2) *Wolffia*
- (3) *Funaria*
- (4) *Selaginella*

Answer (1)

121. Which of the following statements are correct with reference to packaging of DNA helix ?

- A. Histones are organized to form a unit of eight molecules called histone octamer.
- B. Histones are negatively charged basic proteins.
- C. Histones are rich in the basic amino acid residues - lysine and arginine.
- D. The positively charged DNA is wrapped around the histone octamer to form nucleosome.
- E. The packaging of chromatin at higher levels requires an additional set of proteins called non-histone chromosomal proteins.

Choose the **correct** answer from the options given below :

- (1) B, D and E only
- (2) A, B and D only
- (3) C, D and E only
- (4) A, C and E only

Answer (4)

122. Match List I with List II :

	List I (Placentation)		List II (Example)
A.	Marginal	I.	Mustard
B.	Axile	II.	Pea
C.	Parietal	III.	Marigold
D.	Basal	IV.	Lemon

Choose the **correct** answer from the options given below :

- (1) A-II, B-IV, C-I, D-III
- (2) A-IV, B-II, C-I, D-III
- (3) A-III, B-I, C-IV, D-II
- (4) A-I, B-III, C-II, D-IV

Answer (1)

123. Which one of the following is the site for active ribosomal RNA synthesis?

- (1) Nucleolus
- (2) Kinetochore
- (3) Centrosome
- (4) Chromatin

Answer (1)

124. The main function of bulliform cells in grasses is :
- (1) to perform photosynthesis.
 - (2) to minimize water loss during water stress.
 - (3) to make the leaf impermeable to fungal spores.
 - (4) to transport water.

Answer (2)

125. Which of the following statements are correct?
- A. The Amazon rainforest being cut and cleared for cultivation of soybeans is an example of habitat loss.
 - B. Steller's sea cow and passenger pigeon became extinct due to over-exploitation by humans.
 - C. The Nile perch introduced into Lake Victoria in East Africa helped in population growth of cichlid fish in the lake.
 - D. Water hyacinth is an invasive species.
 - E. When a species becomes extinct, the plant and animal species associated with it are not affected.

Choose the **correct** answer from the options given below:

- (1) A, B and D only
- (2) B, C and D only
- (3) A, B and E only
- (4) C, D and E only

Answer (1)

126. Which one of the following statements is **not** true about the universal rules of binomial nomenclature?
- (1) The first word in the biological name represents the specific epithet, while the second component denotes the genus
 - (2) The specific epithet in the biological name starts with a small letter
 - (3) Both the words in a biological name, when handwritten, are separately underlined or printed in italics
 - (4) Biological names are generally in Latin

Answer (1)

127. Which one of the following disorders is caused by the substitution of Glutamic acid (Glu) by Valine (Val) at the sixth position of the beta globin chain of the haemoglobin molecule?
- (1) Phenylketonuria
 - (2) Haemophilia
 - (3) Sickle-cell anaemia
 - (4) Thalassemia

Answer (3)

128. Find the **incorrect** statement(s) about photosynthesis from the following:
- A. The water splitting complex is associated with PS I.
 - B. C_4 plants use the C_3 pathway of CO_2 fixation as the main biosynthetic pathway.
 - C. In C_4 plants, photorespiration does not occur.
 - D. C_3 plants exhibit 'Kranz' anatomy.
 - E. ATP synthesis in chloroplast occurs through chemiosmosis.

Choose the answer from the options given below:

- (1) B and C only
- (2) B and E only
- (3) B only
- (4) A and D only

Answer (4)

129. Match List I with List II :

	List I		List II
A.	Trypsin	I.	Intercellular ground substance
B.	Morphine	II.	Lectin
C.	Concanavalin A	III.	Enzyme
D.	Collagen	IV.	Alkaloid

Choose the **correct** answer from the options given below :

- (1) A-III, B-IV, C-II, D-I
- (2) A-IV, B-III, C-II, D-I
- (3) A-I, B-II, C-III, D-IV
- (4) A-III, B-II, C-IV, D-I

Answer (1)

130. Identify the correct statements about biomolecules.

- A. Lipids are generally water soluble.
- B. Proteins are polypeptides.
- C. Polysaccharides are long chains of sugars.
- D. Adenine and guanine are substituted pyrimidines.
- E. Almost all enzymes are proteins.

Choose the **correct** answer from the options given below :

- (1) A, B and C only
- (2) B, D and E only
- (3) B, C and E only
- (4) C, D and E only

Answer (3)

131. Match List I with List II :

	List-I		List-II
A.	Incomplete dominance	I.	Human skin colour
B.	Co-dominance	II.	Inheritance of flower colour in <i>Antirrhinum</i> sp.
C.	Pleiotropy	III.	Phenylketonuria disease in humans
D.	Polygenic inheritance	IV.	ABO blood groups

Choose the **correct** answer from the options given below :

- (1) A-I, B-IV, C-III, D-II
- (2) A-I, B-III, C-II, D-IV
- (3) A-II, B-IV, C-III, D-I
- (4) A-II, B-I, C-III, D-IV

Answer (3)

132. Identify the **correct** sequence of steps in each cycle of Polymerase Chain Reaction :

- (1) Denaturation → Extension → Annealing
- (2) Denaturation → Annealing → Extension
- (3) Annealing → Denaturation → Extension
- (4) Extension → Annealing → Denaturation

Answer (2)

133. How many ATP and NADPH molecules are required to make one molecule of glucose through the Calvin pathway?

- (1) 12 ATP and 18 NADPH
- (2) 18 ATP and 12 NADPH
- (3) 6 ATP and 12 NADPH
- (4) 24 ATP and 18 NADPH

Answer (2)

134. Match **List-I** with List-II:

	List-I (Process)		List-II (Location)
A.	Glycolysis	I.	Inner mitochondrial membrane
B.	ETS	II.	Mitochondrial matrix
C.	Accumulation of protons	III.	Cytoplasm
D.	Krebs' cycle	IV.	Intermembrane space

Choose the **correct** answer from the options given below:

- (1) A-IV, B-II, C-I, D-III
- (2) A-I, B-IV, C-III, D-II
- (3) A-II, B-III, C-IV, D-I
- (4) A-III, B-I, C-IV, D-II

Answer (4)

135. Which of the following statements are correct with respect to DNA separation, isolation and visualization?

- A. The cutting of DNA is done by molecular scissors.
- B. The DNA fragments separate according to their size in an agarose gel, upon electrophoresis.
- C. The separated DNA fragments can be seen without staining when exposed to UV light.
- D. The separated DNA fragments, when stained with ethidium bromide, can be seen in visible light.

Choose the **correct** answer from the options given below :

- (1) A and B only
- (2) B and D only
- (3) A and D only
- (4) B and C only

Answer (1)

136. What is the probability of having children with 'O' blood group, where both mother and father are heterozygous for 'A' and 'B' blood group, respectively?

- (1) 0% (2) 50%
(3) 25% (4) 75%

Answer (3)

137. Match List I with List II:

	List I		List II
A.	Molluscs	I.	Pulmonary respiration only
B.	Reptiles	II.	Branchial respiration
C.	Adult amphibians	III.	Cellular respiration
D	<i>Amoeba</i>	IV	Pulmonary and cutaneous respiration

Choose the **correct** answer from the options given below:

- (1) A-III, B-II, C-I, D-IV (2) A-II, B-I, C-III, D-IV
(3) A-I, B-II, C-IV, D-III (4) A-II, B-I, C-IV, D-III

Answer (4)

138. Insertion of a foreign DNA at BamHI site in an *E. coli* cloning vector pBR322 results in the loss of antibiotic resistance towards:

- (1) Ampicillin and tetracycline
(2) Ampicillin
(3) Tetracycline
(4) Gentamycin

Answer (3)

139. What is the reason behind production of large holes in 'Swiss Cheese'?

- (1) The production of large amount of CO₂ and H₂ by *Trichoderma polysporum*
(2) The production of large amount of CO₂ and H₂ by lactic acid bacteria called *Lactobacillus*
(3) The production of large amount of CO₂ by *Propionibacterium sharmanii*
(4) The production of large amount of CO₂ by *Clostridium butylicum*

Answer (3)

140. Which of the following is **not** an example of convergent evolution?

- (1) Fore limbs of whales and bats
(2) Flippers of penguins and dolphins
(3) Eyes of octopuses and mammals
(4) Wings of butterflies and birds

Answer (1)

141. Non-membrane bound cell organelles found in both prokaryotic and eukaryotic cells are _____.
- (1) Lysosomes
 - (2) Centrosomes
 - (3) Mitochondria
 - (4) Ribosomes

Answer (4)

142. Ecological pyramids represent the relationship between the organisms at different trophic levels and they are generally inverted for:
- (1) Pyramid of number in grassland
 - (2) Pyramid of energy in pond ecosystem
 - (3) Pyramid of biomass in grassland
 - (4) Pyramid of biomass in sea

Answer (4)

143. Arrange the following events occurring in Renin-Angiotensin mechanism in the correct order:
- A. Increase in blood pressure and Glomerular filtration rate
 - B. Reabsorption of Na^+ and water from distal parts of tubule due to Aldosterone
 - C. Fall in Glomerular filtration rate
 - D. Vasoconstriction by Angiotensin II and release of Aldosterone.
 - E. Renin converts Angiotensinogen into Angiotensin I, followed by Angiotensin II.

Choose the **correct** answer from the options given below:

- (1) A, C, E, B, D
- (2) C, A, B, D, E
- (3) A, D, B, E, C
- (4) C, E, D, B, A

Answer (4)

144. Choose the correct statements regarding population interactions between two species.
- A. In both parasitism and commensalism, only one species benefits and the other species is harmed.
 - B. Both species benefit in mutualism.
 - C. Both species benefit in commensalism.
 - D. In parasitism, only one species benefits and the other species is harmed.
 - E. In amensalism, one species is harmed and the other is unaffected.

Choose the **correct** answer from the options given below:

- (1) A and B only
- (2) B and E only
- (3) B, D and E only
- (4) A and D only

Answer (3)

145. In which animal do haploid cells divide mitotically to produce gametes?

- (1) Male honeybees (2) Male grasshoppers
(3) Male earthworms (4) Male frogs

Answer (1)

146. In humans, respiration occurs in the following steps. Arrange these steps in the correct order.

- A. Diffusion of O₂ and CO₂ between blood and tissues
B. Diffusion of O₂ and CO₂ across alveolar membrane
C. Pulmonary ventilation by which atmospheric air is drawn in and CO₂ rich alveolar air is released out
D. Cellular respiration
E. Transport of gases by the blood

Choose the **correct** answer from the options given below

- (1) A, B, C, D, E (2) C, A, B, E, D
(3) C, B, E, A, D (4) E, A, C, D, B

Answer (3)

147. The following reaction depicts the activity of a particular class of enzymes :

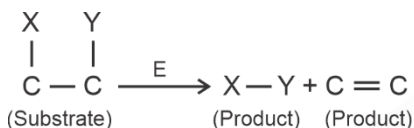

Identify the enzymes class 'E' from the following options :

- (1) Isomerases (2) Ligases
(3) Transferases (4) Lyases

Answer (4)

148. Match List I with List II:

	List I (Bioactive molecules)		List II (Importance)
A.	Streptokinase	I.	Immunosuppressive agent
B.	Statins	II.	Removal of clots from the blood vessels
C.	Lipases	III.	Blood cholesterol-lowering agent
D.	Cyclosporin A	IV	Detergent formulations

Choose the correct answer from the options given below:

- (1) A-II, B-III, C-I, D-IV
(2) A-III, B-II, C-IV, D-I
(3) A-II, B-III, C-IV, D-I
(4) A-IV, B-III, C-II, D-I

Answer (3)

149. Which of the following equations depicts Verhulst-Pearl logistic population growth?

$$(1) \frac{dN}{dt} = rN \left(\frac{K - N}{K} \right)$$

$$(2) \frac{dN}{dt} = rN \left(\frac{K}{K - N} \right)$$

$$(3) \frac{dN}{dt} = rN \left(\frac{K - N}{N} \right)$$

$$(4) \frac{dN}{dt} = rN \left(\frac{K + N}{K} \right)$$

Answer (1)

150. Arrange the following cell layers/structures around the female gamete, from outer to inner side :

- A. Zona pellucida
- B. Perivitelline space
- C. Corona radiata
- D. Plasma membrane of ovum

Choose the **correct** answer from the options given below :

(1) D, B, A, C

(2) A, C, B, D

(3) C, A, D, B

(4) C, A, B, D

Answer (4)

151. Which one of the following is an appropriate example of sexual deceit?

- (1) Sea anemone and clown fish
- (2) *Ophrys* and bumblebee
- (3) Female wasp and fig
- (4) Cuckoo and crow

Answer (2)

152. Match List I with List II related to muscular/skeletal system:

	List I		List II
A.	Tetany	(I)	Inflammation of joints
B.	Arthritis	(II)	Autoimmune disorder affecting neuromuscular junction
C.	Myasthenia gravis	(III)	Wild contraction in muscle due to low Ca^{++} in body fluid
D.	Muscular dystrophy	(IV)	Progressive degeneration of skeletal muscle

Choose the **correct** answer from the options given below:

- (1) A-IV, B-III, C-II, D-I
- (2) A-III, B-I, C-II, D-IV
- (3) A-I, B-II, C-III, D-IV
- (4) A-III, B-II, C-I, D-IV

Answer (2)

153. Select the correct statements regarding cell membrane in eukaryotic cell.
- A. Membrane of human RBCs has approximately 52% protein.
 - B. Major phospholipids are arranged in a bilayer.
 - C. Extensions of the plasma membrane into the cell form mesosomes.
 - D. Tails towards the inner part of lipids are hydrophobic and thus protected from aqueous medium.
 - E. Glycocalyx is present on the outer surface of the plasma membrane.

Choose the **correct** answer from the options given below:

- (1) C, D and E only
- (2) B, C and E only
- (3) A, B and D only
- (4) A, C and E only

Answer (3)

154. Choose the correct statements regarding cell organelles and their inclusions.
- A. The endomembrane system includes Golgi complex, endoplasmic reticulum and mitochondria.
 - B. Rough endoplasmic reticulum bears ribosomes on its surface.
 - C. Both mitochondria and plastids have circular DNA.
 - D. A network of microtubules, microfilaments and intermediate filaments present in the cytoplasm is called cytoskeleton.
 - E. Mitochondrion is a single membrane-bound structure.

Choose the **correct** answer from the options given below :

- (1) A, B and C only
- (2) C, D and E only
- (3) A and B only
- (4) B, C and D only

Answer (4)

155. The toxin proteins isolated from *Bacillus thuringiensis*, coded by which of the following genes would control cotton bollworms and corn borer, respectively?
- (1) *cryIAc* and *cryIIAb*
 - (2) *cryIAc* and *cryIIIAb*
 - (3) *cryIAc* and *cryIAb*
 - (4) *cryIIAb* and *cryIAc*

Answer (3)

156. The JGA (Juxta Glomerular Apparatus) is a special sensitive region formed by cellular modifications in _____ related to the same nephron.
- (1) Proximal convoluted tubule and efferent renal arteriole
 - (2) Distal convoluted tubule and efferent renal arteriole
 - (3) Distal convoluted tubule and afferent renal arteriole
 - (4) Proximal convoluted tubule and afferent renal arteriole

Answer (3)

157. Choose the correct statements regarding frog's anatomy:

- A. Hepatic portal system is the special venous connection between liver and intestine.
- B. There are twelve pairs of cranial nerves arising from the brain.
- C. The ureters and oviducts open separately into the cloaca in female frogs.
- D. Hind-brain consists of cerebellum, medulla oblongata and optic lobes.
- E. Sinus venosus joins the right atrium of heart.

Choose the **correct** answer from the options given below:

- (1) B and D only
- (2) A, B and C only
- (3) B and C only
- (4) A, C and E only

Answer (4)

158. Match List I with List II:

	List-I		List-II
A.	Cortisol	I.	Stimulates the formation of alveoli in mammary glands
B.	Aldosterone	II.	Produces anti-inflammatory reactions
C.	Cholecystokinin	III.	Stimulates reabsorption of Na ⁺ and water from renal tubule
D.	Progesterone	IV.	Stimulates secretion of pancreatic enzymes and bile juice

Choose the **correct** answer from the options given below:

- (1) A-II, B-III, C-IV, D-I
- (2) A-II, B-III, C-I, D-IV
- (3) A-IV, B-II, C-I, D-III
- (4) A-III, B-II, C-IV, D-I

Answer (1)

159. The sixth mutant codon of beta globin gene causing polymerization of Haemoglobin and change in RBC shape is _____.

- (1) CAG
- (2) AUG
- (3) GUG
- (4) GAG

Answer (3)

164. Match List I with List II with respect to chronology of evolution of life forms

	List-I		List-II
A.	About 65 mya	(I)	Jawless fish probably evolved
B.	About 500 mya	(II)	The dinosaurs suddenly disappeared from the earth
C.	About 350 mya	(III)	Seaweeds and few plants probably existed
D.	About 320 mya	(IV)	Invertebrates were formed and became active

Choose the **correct** answer from the options given below:

- (1) A(III), B(IV), C(I), D(II)
- (2) A(II), B(IV), C(III), D(I)
- (3) A(II), B(IV), C(I), D(III)
- (4) A(I), B(II), C(III), D(IV)

Answer (3)

165. Match List I and List II

	List-I		List-II
A.	Progestasert	(I)	Barrier made of rubber used by females
B.	Multiload 375	(II)	Oral contraceptive
C.	Diaphragm	(III)	Hormone releasing IUD
D.	Saheli	(IV)	Copper releasing IUD

Choose the **correct** answer from the options given below:

- (1) A(IV), B(II), C(I), D(III)
- (2) A(IV), B(III), C(I), D(II)
- (3) A(III), B(IV), C(II), D(I)
- (4) A(III), B(IV), C(I), D(II)

Answer (4)

166. The following are the stages of life cycle of *Plasmodium*. Arrange the stages in the proper order.

- A. The parasites reproduce asexually in RBCs, bursting the cells.
- B. The parasites reproduce asexually in liver cells, bursting the cells and releasing into blood.
- C. Gametocytes develop in RBCs.
- D. Sporozoites reach the liver through the blood.
- E. Female mosquito injects sporozoites into humans during bite.

Choose the **correct** answer from the options given below:

- (1) A, B, C, D, E
- (2) E, C, D, B, A
- (3) E, D, B, A, C
- (4) C, A, B, D, E

Answer (3)

167. Match **List I** with **List II** related to embryonic development at various months of pregnancy:

	List-I		List-II
A.	The foetus movement starts and hair appears on the head	(I)	24 weeks of pregnancy
B.	The foetus develops limbs and digits	(II)	20 weeks of pregnancy
C.	The foetus develops external genital organs	(III)	8 weeks of pregnancy
D.	The foetus body is covered with fine hair; eyelids separate and eyelashes are formed	(IV)	12 weeks of pregnancy

Choose the **correct** answer from the options given below:

- (1) A-II, B-IV, C-III, D-I
- (2) A-II, B-III, C-IV, D-I
- (3) A-IV, B-II, C-III, D-I
- (4) A-III, B-II, C-IV, D-I

Answer (2)

168. The flightless bird with forelimbs modified as paddle-like structures suited for swimming is known as:

- (1) *Psittacula*
- (2) *Aptenodytes*
- (3) *Neophron*
- (4) *Struthio*

Answer (2)

169. Select the **incorrect** statements from the following:

- A. Digestive system in Platyhelminthes is incomplete.
- B. Bilateral symmetry is a characteristic feature of adult Echinoderms.
- C. Pseudocoelom is possessed by Aschelminthes.
- D. Notochord is persistent throughout life in the class Chondrichthyes.
- E. Members of class Reptilia maintain a constant body temperature.

Choose the answer from the options given below:

- (1) A and C only
- (2) B and E only
- (3) B and D only
- (4) C and D only

Answer (2)

174. Spermatogonia undergo a series of cell divisions statements to produce sperms. Select the correct from the following :

- A. Spermatogonia always undergo meiotic cell division.
- B. Primary spermatocytes divide mitotically to produce secondary spermatocytes.
- C. Secondary spermatocytes, through their second meiotic division, produce haploid spermatids.
- D. Spermatids produce spermatozoa through mitosis.
- E. Spermatids transform into spermatozoa by spermiogenesis.

Choose the correct answer from the options given below:

- (1) A, C and E only
- (2) C and E only
- (3) A and E only
- (4) B, C and D only

Answer (2)

175. Select the **incorrect** statement with reference to Rh grouping.

- A. Erythroblastosis foetalis is a condition observed having foetus with Rh^{-ve} blood and mother with Rh^{+ve} blood.
- B. Rh antigen is observed on RBCs in the majority of human beings.
- C. Before blood transfusion, Rh group should also be matched.
- D. Rh incompatibility is observed when a pregnant mother is Rh^{-ve} and the foetus is Rh^{+ve}.
- E. Erythroblastosis foetalis can be avoided by administering anti-Rh antibodies to the mother immediately after the delivery of the second child.

Choose the answer from the options given below :

- (1) A and B only
- (2) C and D only
- (3) A and E only
- (4) B and C only

Answer (3)

176. Select the set of fishes which belong to the class Osteichthyes:

- (1) Saw fish, Fighting fish and Dog fish
- (2) Devil fish, Cuttlefish and Hagfish
- (3) Starfish, Hagfish and Cuttlefish
- (4) Flying fish, Angel fish and Fighting fish

Answer (4)

177. In a population of a grasshopper species, the chromosome number of some members is 23 and some other members possess 24 chromosomes. The 23 and 24 chromosome-bearing members in this species are _____.

- (1) females and males, respectively
- (2) males and females, respectively
- (3) all males
- (4) all females

Answer (2)

178. Evolution of human appears parallel to the progressive development of brain and language skills. As such, the evolution of individual species in the sequence of their appearance is:

- (1) *Ramapithecus* → *Homo habilis* → *Homo erectus* → *Neanderthal* → *Homo sapiens*
- (2) *Neanderthal* → *Ramapithecus* → *Homo habilis* → *Homo erectus* → *Homo sapiens*
- (3) *Homo habilis* → *Homo erectus* → *Ramapithecus* → *Neanderthal* → *Homo sapiens*
- (4) *Homo sapiens* → *Ramapithecus* → *Homo habilis* → *Neanderthal* → *Homo erectus*

Answer (1)

179. The specific receptors for neurotransmitters in a synapse are present on _____.

- (1) Pre-synaptic membrane
- (2) Post-synaptic membrane
- (3) Myelin sheath
- (4) Schwann cell

Answer (2)

180. Match List-I with List-II.

	List-I (Respiratory Volume)		List-II (Capacity in mL)
A.	ERV (Expiratory Reserve Volume)	I.	2500 – 3000 mL
B.	RV (Residual Volume)	II.	500 mL
C.	IRV (Inspiratory Reserve Volume)	III.	1000 – 1100 mL
D.	TV (Tidal Volume)	IV.	1100 – 1200 mL

Choose the **correct** answer from the options given below :

- (1) A-III, B-IV, C-I, D-II
- (2) A-III, B-I, C-IV, D-II
- (3) A-I, B-II, C-III, D-IV
- (4) A-I, B-III, C-II, D-IV

Answer (1)

