

DATE: 21/06/2026

Test Booklet Code



**50**

**SUSHRUT**

Corporate Office: 3rd Floor, Incuspaze Campus-2, Plot No. 13,  
Sector-18, Udyog Vihar, Gurugram, Haryana - 122015.

## Questions & Answers for

Time : 3 hrs. 15 min.

M.M. : 720

## NEET (UG)-2026 (Re-Examination)

### Important Instructions:

1. The test is of **3 hours 15 minutes** duration and the Test Booklet contains **180** multiple choice questions (Four options with a single correct answer) from **Physics, Chemistry & Biology (Botany and Zoology)**.
2. Each question carries **4 marks**. For each correct response, the candidate will get **4 marks**. For each incorrect response, **1 mark** will be deducted from the total scores. The maximum marks are **720**.
3. Use **Blue / Black Ball Point Pen only** for writing particulars on this page / marking responses on Answer Sheet.
4. Rough work is to be done in the space provided for this purpose in the Test Booklet only.
5. On completion of the test, the candidate **must handover the Answer Sheet (original & office copy) to the Invigilator** before leaving the Room / Hall. The candidates are allowed to take away this Test Booklet with them.
6. The **CODE** for this Booklet is **50**.
7. The candidates should ensure that the Answer Sheet is not folded. Do not make any stray marks on the Answer Sheet. Do not write your Roll No. anywhere else except in the specified space in the Test Booklet/Answer Sheet. Use of white fluid for correction is **NOT** permissible on the Answer Sheet.
8. Each candidate must show on-demand his/her Admit Card to the Invigilator.
9. No candidate, without special permission of the Centre Superintendent or Invigilator, would leave his/her seat.
10. Use of Electronic/Manual Calculator is prohibited.
11. The candidates are governed by all Rules and Regulations of the examination with regard to their conduct in the Examination Hall. All cases of unfair means will be dealt with as per Rules and Regulations of this examination.
12. No part of the **Test Booklet** and **Answer Sheet** shall be detached under any circumstances.
13. The candidates will write the Correct Test Booklet Code as given in the Test Booklet / Answer Sheet in the Attendance Sheet.

**PHYSICS**

1. A particle of mass  $M$  moves along a horizontal  $x$  axis from  $x = 0$  to  $x = L$ . The coefficient of kinetic friction varies as a function of  $x$  as  $\mu_k(x) = \mu_0 - \alpha x$ , where  $\mu_0, \alpha$  are constants of appropriate dimensions, so that  $\mu_k(L) = 0$ . The total work done by the frictional force during the motion is  $n\mu_0 MgL$ , where  $g$  is the acceleration due to gravity. The value of  $n$  is:

- (1) 3 (2) 1  
(3)  $\frac{1}{3}$  (4)  $\frac{1}{2}$

**Answer (4)**

2. The mean free path of molecules in an ideal gas  $A$  is half that of another ideal gas  $B$ . The diameter of the spherical molecules of gas  $A$  is twice the diameter of the molecules of  $B$ . If number densities of the gases  $A$  and  $B$  are  $n_A$  and  $n_B$ , respectively, the correct option is:

- (1)  $n_A = n_B$  (2)  $n_A = 2n_B$   
(3)  $n_A = \frac{1}{4}n_B$  (4)  $n_A = \frac{1}{2}n_B$

**Answer (4)**

3. Two identical inductors are connected in two different configurations  $P$  and  $Q$ , where a time varying current  $I(t)$  is flowing, as shown in the figure. The induced emf between points  $a$  and  $b$  for configuration  $P$  is  $E_P$  and that for configuration  $Q$  is  $E_Q$ . The ratio  $E_P/E_Q$  is:

[Neglect the effect of mutual inductance.]

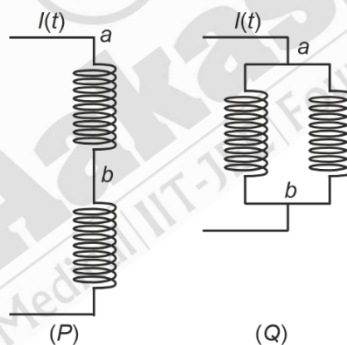

- (1)  $\frac{1}{4}$  (2)  $\frac{1}{2}$   
(3) 1 (4) 2

**Answer (4)**

4. For sound waves, if the number of nodes for the 5<sup>th</sup> harmonic of an open-ended pipe is  $n$  and that for the 9<sup>th</sup> harmonic of the same pipe with one of its ends closed is  $m$ , the ratio  $\frac{n}{m}$  is

- (1)  $\frac{5}{9}$  (2)  $\frac{9}{5}$   
(3) 1 (4)  $\frac{3}{5}$

**Answer (3)**

5. Consider a long solenoid of length  $l$  and radius  $r$ . If  $n$  is the number of turns per unit length and  $\mu_0$  is the permeability of free space, the inductance of the solenoid is :

- (1)  $\mu_0 \pi n^2 r^2 l$  (2)  $\mu_0 n^2 r^2 l$   
 (3)  $(\mu_0 / 2\pi) n^2 r^2 l$  (4)  $2\mu_0 \pi n^2 r^2 l$

**Answer (1)**

6. Consider a particle moving along a straight line, whose position as a function of time is given by  $s(t) = \alpha t^2 - \beta t + \gamma$ , where  $\alpha = 1 \text{ ms}^{-2}$ ,  $\beta = 6 \text{ ms}^{-1}$  and  $\gamma = 5 \text{ m}$ . The average speed of the particle, in  $\text{ms}^{-1}$  from  $t = 0$  to  $t = 6 \text{ s}$  is:

- (1) 12 (2) 6  
 (3) 3 (4) 0

**Answer (3)**

7. Consider the following nuclear reaction

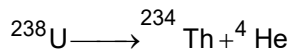

Take masses of  ${}^{238}\text{U}$ ,  ${}^{234}\text{Th}$  and  ${}^4\text{He}$  as 238.050 u, 234.043 u and 4.003 u, respectively. The Q value for the reaction, in keV, is:

[Given:  $1 \text{ u} = 931.5 \text{ MeV c}^{-2}$ ]

- (1) 3726 (2) 3730  
 (3) 3736 (4) 3740

**Answer (1)**

8. A beam of light falls on a metal surface such that photo-electrons are generated. If power of the light source starts to decrease linearly with time  $t$ , then variation of the photocurrent  $I$  and magnitude of the stopping potential  $|V|$  with time is best represented by:

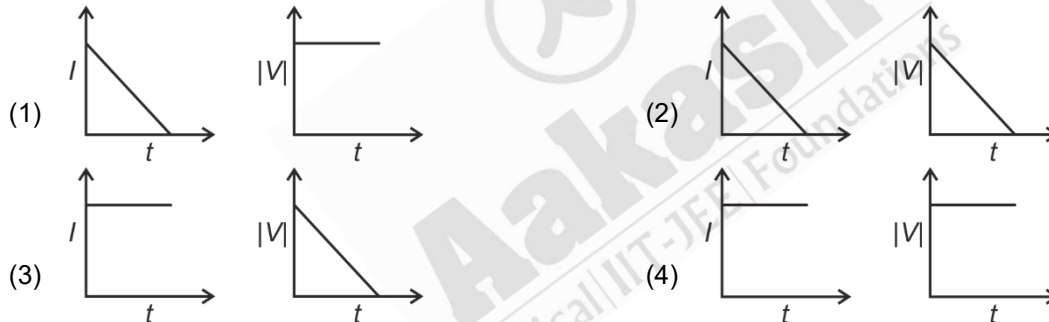

**Answer (1)**

9. Three identical capacitors,  $P$ ,  $Q$  and  $S$ , each of the capacitance  $C$ , are connected to a battery of voltage  $V$ , as shown in the figure. If the energy stored in the capacitor  $P$  and total energy stored in the system are  $U_P$

and  $U_T$ , respectively, then the ratio  $\frac{U_P}{U_T}$  is:

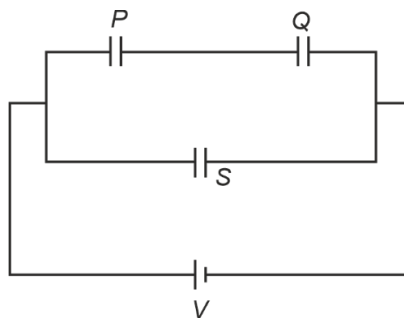

- (1)  $2/3$  (2)  $1/3$   
 (3)  $1/2$  (4)  $1/6$

**Answer (4)**

10. Water flows in a streamline motion through a horizontal pipe of circular cross-section as shown in the figure. The pressure difference of water between  $P$  and  $Q$  is  $15 \text{ Nm}^{-2}$ . The area of cross-section at  $P$  and  $Q$  are  $40 \text{ cm}^2$  and  $20 \text{ cm}^2$ , respectively. The rate of flow of water through the pipe, in  $\text{cm}^3\text{s}^{-1}$ , is:  
[Take density of water =  $1000 \text{ kg m}^{-3}$ ]

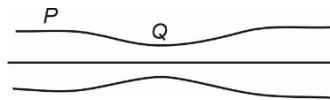

- (1) 100  
(2) 200  
(3) 300  
(4) 400

**Answer (4)**

11. A current  $I_0$  flows through a metallic circular loop of radius  $r$  as shown in the figure. Resistance of the segment  $ABC$  is half that of  $ADC$ . Magnitude of magnetic field at the centre  $O$  of the loop is :

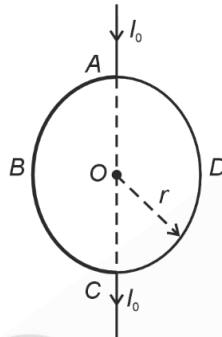

- (1)  $\frac{\mu_0 I_0}{12r}$   
(2)  $\frac{\mu_0 I_0}{4r}$   
(3)  $\frac{\mu_0 I_0}{2r}$   
(4)  $\frac{\mu_0 I_0}{2\pi r}$

**Answer (1)**

12. In the measurement of viscosity of liquids using terminal velocity experiment, spherical balls of same radius but having different densities are used. The variation of the terminal velocity ( $v$ ) with the ratio of density of spherical ball ( $\sigma$ ) to density of the liquid ( $\rho$ ), is best represented by:



**Answer (1)**

13. Two planets  $P_1$  and  $P_2$  with equal mass have radii  $R_1$  and  $R_2$ , respectively, where  $R_2 = \frac{R_1}{2}$ . The escape speeds of  $P_1$  and  $P_2$  are  $v_1$  and  $v_2$ , respectively. Then  $\frac{v_2}{v_1}$  is:

- (1)  $\frac{1}{\sqrt{2}}$   
(2) 1  
(3)  $\sqrt{2}$   
(4) 2

**Answer (3)**

14. In a solar system, the time-period of revolution of a planet tracing a circular orbit of radius  $R$  is proportional to:
- (1)  $R^{1/2}$  (2)  $R^{3/2}$   
 (3)  $R^2$  (4)  $R^3$

**Answer (2)**

15. Two infinitely long parallel conducting wires  $A$  and  $B$  carry currents  $I$  and  $2I$ , respectively, in the same direction. The wire  $A$  has uniform mass per unit length  $\lambda$  and lies on an insulated floor. The wire  $B$  is kept fixed at a height  $h$  above the floor. The minimum magnitude of  $h$  so that the wire  $A$  does not rise from the floor is: [g is the acceleration due to gravity and  $\mu_0$  is the permeability of free space.]

- (1)  $\frac{\mu_0 I^2}{2\pi\lambda g}$  (2)  $\frac{\mu_0 I^2}{\pi\lambda g}$   
 (3)  $\frac{2\mu_0 I^2}{\pi\lambda g}$  (4)  $\frac{4\mu_0 I^2}{\pi\lambda g}$

**Answer (2)**

16. An ideal Zener diode with breakdown voltage of  $-3$  V is reverse biased with a negative input voltage  $V_i = -5$  V. The magnitude of voltage difference between point  $B$  and  $A$  is:

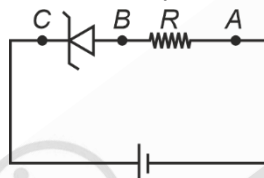

- (1) 3 V (2) 2 V  
 (3) 1 V (4) 0 V

**Answer (2)**

17. In an adiabatic expansion, the temperature of one mole of an ideal monatomic gas ( $\gamma = 5/3$ ) decreases from 60 K to 50 K. The work done by the gas in the process is: (Take the universal gas constant as  $R = 8.3$  J mol $^{-1}$  K $^{-1}$ )
- (1) 41.5 J (2) 83 J  
 (3) 124.5 J (4) 166 J

**Answer (3)**

18. A ray of light with wavelength  $\lambda$  is incident on three different photoelectric cells namely 1, 2 and 3. The threshold wavelength of these photoelectric cells are  $\lambda_1$ ,  $\lambda_2$ , and  $\lambda_3$ , respectively and the magnitude of stopping potentials of these cells are  $V_1$ ,  $V_2$  and  $V_3$ , respectively. The relation between  $\lambda$  and threshold wavelengths are  $\lambda_1 < \lambda$ ,  $\lambda_2 > \lambda$  and  $\lambda_3 \gg \lambda$ . The correct option is:
- (1)  $V_1 = 0, V_2 < V_3$  (2)  $V_1 = 0, V_2 > V_3$   
 (3)  $V_1 > V_2, V_3 = 0$  (4)  $V_1 < V_2, V_3 = 0$

**Answer (1)**

19. A photon and an electron, each of 20 eV energy, move in free space. The ratio of linear momentum of electron  $p_e$  to that of photon  $p_{Ph}$ ,  $\frac{p_e}{p_{Ph}}$  is:

[Take speed of light =  $3 \times 10^8$  ms $^{-1}$ , charge of electron =  $-1.6 \times 10^{-19}$  C and mass of electron =  $9 \times 10^{-31}$  kg]

- (1)  $\frac{2}{450}$  (2)  $\frac{1}{250}$   
 (3) 225 (4) 275

**Answer (3)**

20. Which of the following measurements require 'index correction'?
- (1) Measurement of resistance of a wire using meter bridge
  - (2) Measurement of gravitational acceleration using simple pendulum
  - (3) Measurement of focal length of lenses using optical bench
  - (4) Measurement of speed of sound using resonance tube

**Answer (3)**

21. A unit positive point charge is taken slowly through an infinitesimally thin tube that is inside a charged dielectric sphere of radius  $R$ , having uniform positive charge density  $\rho$ , as shown in the figure. The initial and final positions of the charge are marked by  $A$  and  $B$  at distance  $2R$  and  $3R$  respectively, from the centre of the sphere. In this process, the magnitude of the total work done on the point charge is  $\frac{\rho R^2}{n\epsilon_0}$ . The value of  $n$  is :

( $\epsilon_0$  is the permittivity of vacuum)

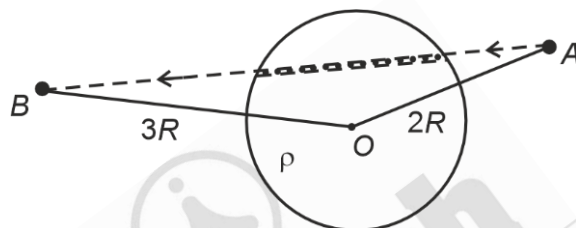

- (1) 2
- (2) 6
- (3) 9
- (4) 18

**Answer (4)**

22. Consider three media  $P$ ,  $Q$  and  $R$  with refractive indices 1, 1.25, and 1.5 respectively. The medium  $Q$  having a thickness of 5 cm is placed between extended media  $P$  and  $R$  as shown in the figure. An object  $O$  is placed at the centre of medium  $Q$ . If viewed from medium  $P$  near the normal direction, the apparent depth of  $O$  is  $h_1$ . For similar observation from medium  $R$ , the apparent depth is  $h_2$ . The value of  $|h_1 - h_2|$ , in cm, is:

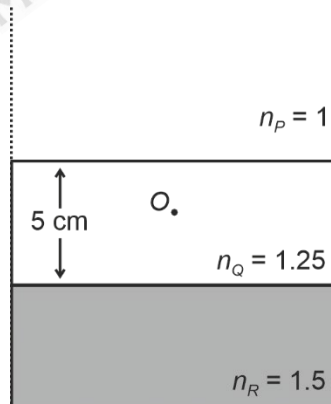

- (1) 0
- (2) 1
- (3) 2
- (4) 3

**Answer (2)**



27. A solid sphere A of radius  $R$  and mass  $M$  is attached at a point to a smaller solid sphere B of radius  $r < R$  and mass  $m < M$ . Assume that the line joining their centres lies along the horizontal. The moment of inertia of the system calculated about a vertical axis passing through the centre of A is  $I_A$  and that calculated about a vertical axis passing through the centre of B is  $I_B$ . The difference  $I_A - I_B$  is:

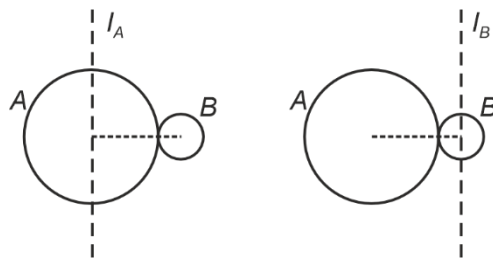

- (1)  $(M - m)(R + r)^2$                       (2)  $(m - M)(R + r)^2$   
(3)  $(m - M)(R - r)^2$                       (4) 0

**Answer (2)**

28. Consider a spring-mass simple harmonic oscillator in one dimension. The mass of the particle is  $m$  kg and the spring constant is  $k$   $\text{Nm}^{-1}$ . At a given instant, the extension of the spring is  $x$ -meter and the speed of the particle is  $v$   $\text{ms}^{-1}$ . On the  $x - v$  plane, if the graph of  $v$  as a function of  $x$  is a circle, then the correct option is:

- (1)  $k = \frac{1}{m}$                                       (2)  $k = m$   
(3)  $k = m^2$                                       (4)  $k = \sqrt{m}$

**Answer (2)**

29. The lens combination as shown in the figure, consists of two lenses,  $L_1$  and  $L_2$ , of the focal lengths  $+10$  cm and  $-10$  cm, respectively. The position of the image formed is:

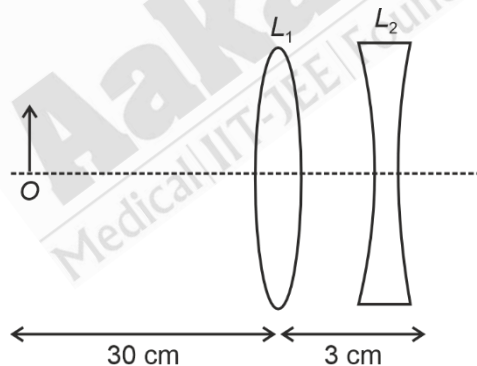

- (1) 20 cm to the left of the concave lens                      (2) 60 cm to the left of the concave lens  
(3) 30 cm to the right of the concave lens                      (4) 60 cm to the right of the concave lens

**Answer (2)**

30. An ac voltage  $V = 220 \sin(2 \times 10^3 t)$  Volt is applied to a series LCR circuit. Then the current amplitude in this circuit is:

(Given :  $L = 10$  mH,  $C = 25$   $\mu\text{F}$ ,  $R = 100$   $\Omega$ )

- (1) 2.2 A                                      (2) 5.5 A  
(3) 11.0 A                                      (4) 22.0 A

**Answer (1)**





38. An electromagnetic wave travelling in a lossless dielectric medium having a dielectric constant,  $\epsilon_r = 9$ , has the electric field,  $E_x = E_0 \sin(kz - 2\pi \times 10^6 t)$   $\text{Vm}^{-1}$  where  $E_0$  is the amplitude and  $k$  is the wave vector. Among the following options, the **incorrect** choice is
- (1) The speed of the electromagnetic wave inside the medium is  $10^8 \text{ ms}^{-1}$
  - (2) The wavelength of the electromagnetic wave inside the medium is 300 m
  - (3) The magnetic field is given by the relation  $B_y = \frac{B_0}{v} \sin(kz - 2\pi \times 10^6 t)$  where  $v$  is the speed of the electromagnetic wave inside the medium
  - (4) The direction of propagation of the electromagnetic wave is along  $+z$

**Answer (2)**

39. One mole of an ideal monatomic gas undergoes a cyclic process as shown in the figure. The total heat supplied to the gas is:

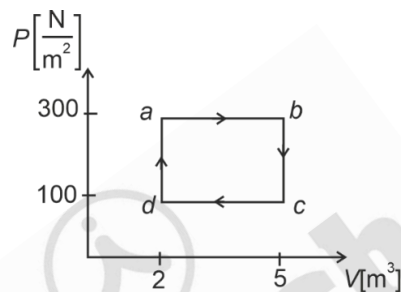

- (1) 400 J
- (2) 500 J
- (3) 600 J
- (4) 800 J

**Answer (3)**

40. Consider that an electron is revolving in an excited state of Hydrogen atom with velocity  $\sqrt{25.6} \times 10^5 \text{ ms}^{-1}$ . The radius of the orbit is  $x \times 10^{-9} \text{ m}$ . The value of  $x$  is:

[Take the mass of electron to be  $9 \times 10^{-31} \text{ kg}$ , charge of electron =  $-1.6 \times 10^{-19} \text{ C}$  and  $\frac{1}{4\pi\epsilon_0} = 9 \times 10^9 \text{ Nm}^2\text{C}^{-2}$ ]

- (1) 4
- (2) 3
- (3) 2
- (4) 1

**Answer (4)**

41. A car travels on a circular racetrack of radius 50 m, which is banked at an angle  $\theta$ . If the car travels at a speed  $10 \text{ ms}^{-1}$ , then the wear and tear on its tyres is minimum. Taking the acceleration due to gravity to be  $10 \text{ ms}^{-2}$ , the value of  $\theta$  is:

- (1)  $\tan^{-1}\left(\frac{1}{5}\right)$
- (2)  $\tan^{-1}\left(\frac{2}{5}\right)$
- (3)  $\tan^{-1}(\sqrt{3}/2)$
- (4)  $\tan^{-1}(2\sqrt{3})$

**Answer (1)**



**CHEMISTRY**

46. For the following reaction sequence, choose the correct option.

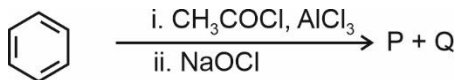

- (1) If **P** is the sodium salt of a carboxylic acid, **Q** is a primary alcohol
- (2) **P** and **Q** are aromatic compounds
- (3) If **P** gives a carboxylic acid on acidification, **Q** gives a poisonous gas on exposure to air and light
- (4) Both **P** and **Q** are carbonyl compounds

**Answer (3)**

47. Given below are two statements:

**Statement-I** :  $[\text{Fe}(\text{ox})_3]^{3-}$  is chiral.

**Statement-II** : *trans* -  $[\text{Cr}(\text{H}_2\text{O})_2(\text{ox})_2]^-$  is chiral.

(Given :  $\text{oxH}_2 = \text{HOOC} - \text{COOH}$ )

In light of the above statements, choose the **most appropriate** answer from the options given below:

- (1) Both **Statement-I** and **Statement-II** are correct
- (2) Both **Statement-I** and **Statement-II** are incorrect
- (3) **Statement-I** is correct but **Statement-II** is incorrect
- (4) **Statement-I** is incorrect but **Statement-II** is correct

**Answer (3)**

48. The following carbocation is stabilized by the interaction of the empty  $p$  orbital with

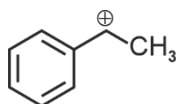

- (1) filled  $\sigma$  and filled  $\pi$  orbitals
- (2) empty  $\sigma$  and empty  $\pi^*$  orbitals
- (3) empty  $\sigma^*$  and filled  $\pi$  orbitals
- (4) empty  $\sigma^*$  and empty  $\pi^*$  orbitals

**Answer (1)**

49. In potash alum, the ratio of  $\text{K}^+$  and  $\text{SO}_4^{2-}$  ions is

- (1) 1 : 2
- (2) 2 : 1
- (3) 2 : 3
- (4) 3 : 2

**Answer (1)**

50. The correct statement about peptides and proteins is
- (1) Tertiary structure of proteins has two or more polypeptide subunits
  - (2) Only the proteins having a quaternary structure are biologically active
  - (3) In  $\beta$ -pleated sheet structures, peptide chains are held together by intermolecular hydrogen bonds
  - (4) In  $\alpha$ -helices, the polypeptide chain is twisted into a left-handed screw (helix) through intramolecular hydrogen bonds

**Answer (3)**

51. The numbers 17.0145 and 21.0235 were rounded to three figures after the decimal point. The resulting numbers, respectively, are
- (1) 17.014 and 21.023
  - (2) 17.015 and 21.023
  - (3) 17.014 and 21.024
  - (4) 17.015 and 21.024

**Answer (3)**

52. The correct order of solubility of the given salts in water at 298 K is

Salt	$K_{sp}$ at 298 K
AgBr	$5.0 \times 10^{-13}$
Zn(OH) <sub>2</sub>	$1.0 \times 10^{-15}$
Hg <sub>2</sub> Cl <sub>2</sub>	$1.3 \times 10^{-18}$

- (1) Hg<sub>2</sub>Cl<sub>2</sub> > Zn(OH)<sub>2</sub> > AgBr
- (2) AgBr > Zn(OH)<sub>2</sub> > Hg<sub>2</sub>Cl<sub>2</sub>
- (3) Hg<sub>2</sub>Cl<sub>2</sub> > AgBr > Zn(OH)<sub>2</sub>
- (4) Zn(OH)<sub>2</sub> > AgBr > Hg<sub>2</sub>Cl<sub>2</sub>

**Answer (4)**

53. Among the following options, the correct trend in the electron gain enthalpy is
- (1) F > Cl > Br > I
  - (2) Br > Cl > F > I
  - (3) Cl > F > Br > I
  - (4) I > Br > Cl > F

**Answer (3)**

54. **Assertion A:** For an ideal solution formed by mixing liquids **P** and **Q**,  $\Delta_{mix} H = 0$  and  $\Delta_{mix} V = 0$

**Reason R:** No interactions occur between **P** and **Q**

In the light of the above statements, choose the **most appropriate** answer from the options given below.

- (1) Both **A** and **R** are correct and **R** is the correct explanation of **A**
- (2) Both **A** and **R** are correct but **R** is **NOT** the correct explanation of **A**
- (3) **A** is correct but **R** is not correct
- (4) **A** is not correct but **R** is correct

**Answer (3)**

55. The amino acid that gives a red-blood colour on treating its sodium fusion extract with sodium nitroprusside is

- (1) leucine
- (2) threonine
- (3) methionine
- (4) serine

**Answer (3)**

56. The standard electrode potential ( $E^\circ$ ) for the half-cell reaction  $\text{Fe}^{3+} + e^- \rightarrow \text{Fe}^{2+}$  at 298 K is  
(Given :  $E^\circ(\text{Fe}^{3+}/\text{Fe}) = -0.04 \text{ V}$  and  $E^\circ(\text{Fe}^{2+}/\text{Fe}) = -0.44 \text{ V}$  at 298 K)

- (1) +0.40 V
- (2) +0.76 V
- (3) -0.48 V
- (4) +0.92 V

**Answer (2)**

57. In an acidic medium, 10 mL of 0.25 M oxalic acid is titrated with  $\text{KMnO}_4$  solution. If the volume of  $\text{KMnO}_4$  solution required to reach end point is 10 mL, the strength of the  $\text{KMnO}_4$  solution is

- (1) 0.10 M
- (2) 0.20 M
- (3) 0.25 M
- (4) 0.15 M

**Answer (1)**

58. According to crystal field theory, the correct order of ligands with respect to their decreasing order of field strength is

- (1)  $\text{CO} > \text{NH}_3 > \text{H}_2\text{O} > \text{Cl}^-$
- (2)  $\text{CO} > \text{H}_2\text{O} > \text{NH}_3 > \text{Cl}^-$
- (3)  $\text{Cl}^- > \text{H}_2\text{O} > \text{NH}_3 > \text{CO}$
- (4)  $\text{Cl}^- > \text{NH}_3 > \text{H}_2\text{O} > \text{CO}$

**Answer (1)**

59. Two moles of an ideal gas undergo free expansion from 10 L to 100 L at 300 K. The values of  $\Delta S_{\text{system}}$  and  $\Delta S_{\text{surroundings}}$  are

(R is universal gas constant)

- (1)  $\Delta S_{\text{system}} = 0$ ;  $\Delta S_{\text{surroundings}} = 0$
- (2)  $\Delta S_{\text{system}} = 4.606 \text{ R}$ ;  $\Delta S_{\text{surroundings}} = -4.606 \text{ R}$
- (3)  $\Delta S_{\text{system}} = 0$ ;  $\Delta S_{\text{surroundings}} = 4.606 \text{ R}$
- (4)  $\Delta S_{\text{system}} = 4.606 \text{ R}$ ;  $\Delta S_{\text{surroundings}} = 0$

**Answer (4)**

60.  $2A \xrightarrow{k} B$  is a zero-order reaction, where  $k = 1.0 \text{ mol L}^{-1} \text{ min}^{-1}$ . If the initial concentration of A is 2 M, then the time taken to complete 75% of the reaction will be
- (1) 1.5 min
  - (2) 0.75 min
  - (3) 1.0 min
  - (4) 2.0 min

**Answer (2)**

61. Given below are two statements: One is labelled as **Assertion A** and the other is labelled as **Reason R**.

**Assertion A:** Generally, 3d transition metals have high melting points.

**Reason R:** Involvement of 3d-electrons in addition to 4s-electrons in the interatomic metallic bonding.

In light of the above statements, choose the **most appropriate** answer from the options given below:

- (1) Both **A** and **R** are correct and **R** is the correct explanation of **A**
- (2) Both **A** and **R** are correct and **R** is **NOT** the correct explanation of **A**
- (3) **A** is correct but **R** is not correct.
- (4) **A** is not correct but **R** is correct

**Answer (1)**

62. For a salt **XY**, which is a strong electrolyte, the plot of  $\Lambda_m$  versus  $\sqrt{c}$  has a slope of  $-90.0 \text{ S cm}^2 \text{ mol}^{-3/2}$   $\text{L}^{1/2}$  at 298 K. At 0.01 M concentration of **XY**, the value of  $\Lambda_m$  is  $145.0 \text{ S cm}^2 \text{ mol}^{-1}$ . The limiting molar conductivity of  $\text{Y}^-$  ion ( $\lambda_{\text{Y}^-}^0$ , in  $\text{S cm}^2 \text{ mol}^{-1}$ ) at 298 K will be

(Given :  $\lambda_{\text{X}^+}^0 = 74.0 \text{ S cm}^2 \text{ mol}^{-1}$ )

- (1) 80.0
- (2) 100.0
- (3) 90.0
- (4) 76.0

**Answer (1)**

63. The amount of carbon dioxide evolved upon complete combustion of 116 g of n-butane is

(Given: atomic mass in amu H = 1, C = 12 and O = 16)

- (1) 352 g
- (2) 322 g
- (3) 176 g
- (4) 362 g

**Answer (1)**

64. For an elementary chemical reaction, the Arrhenius plot is given below.

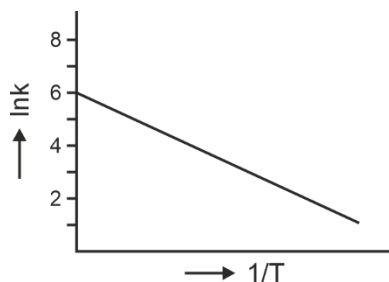

If the energy of activation is  $6.64 \text{ kJ mol}^{-1}$  and  $R = 8.3 \text{ J K}^{-1} \text{ mol}^{-1}$ , the temperature at which the rate constant becomes  $e^2 \text{ min}^{-1}$ , is

- (1) 125 K
- (2) 150 K
- (3) 200 K
- (4) 250 K

**Answer (3)**

65. Given below are two statements :

**Statement-I** : Heating NaCl with concentrated  $\text{H}_2\text{SO}_4$  and  $\text{MnO}_2$  results in oxidation of Mn.

**Statement-II** : Heating NaI with concentrated  $\text{H}_2\text{SO}_4$  and  $\text{MnO}_2$  results in reduction of Mn.

In light of the above statements, choose the **most appropriate** answer from the options given below.

- (1) Both **Statement-I** and **Statement-II** are correct
- (2) Both **Statement-I** and **Statement-II** are incorrect
- (3) **Statement-I** is correct but **Statement-II** is incorrect
- (4) **Statement-I** is incorrect but **Statement-II** is correct

**Answer (4)**

66. Among the species given below, the spin-only magnetic moment is highest for

(Given: Atomic number of Ti = 22, Mn = 25, Fe = 26 and Co = 27)

- (1)  $[\text{Mn}(\text{CN})_6]^{3-}$
- (2)  $[\text{Fe}(\text{CN})_6]^{3-}$
- (3)  $[\text{Co}(\text{NH}_3)_6]^{3+}$
- (4)  $[\text{Ti}(\text{H}_2\text{O})_6]^{3+}$

**Answer (1)**

67. The lanthanide ion having four unpaired electrons is  
(Given : Atomic numbers of Ce = 58, Nd = 60, Tb = 65 and Ho = 67)
- (1)  $\text{Nd}^{3+}$  (2)  $\text{Ce}^{3+}$   
(3)  $\text{Tb}^{3+}$  (4)  $\text{Ho}^{3+}$

**Answer (4)**

68. The formula of tetraammineaquachloridocobalt(III) chloride is
- (1)  $[\text{Co}(\text{NH}_3)_4\text{Cl}_2] \times \text{H}_2\text{O}$   
(2)  $[\text{Co}(\text{NH}_3)_4]\text{Cl}_3 \times \text{H}_2\text{O}$   
(3)  $[\text{Co}(\text{NH}_3)_4(\text{H}_2\text{O})\text{Cl}]\text{Cl}$   
(4)  $[\text{Co}(\text{NH}_3)_4(\text{H}_2\text{O})\text{Cl}]\text{Cl}_2$

**Answer (4)**

69. Consider the reversible processes for 1.0 mol of an ideal gas as shown in the figure.

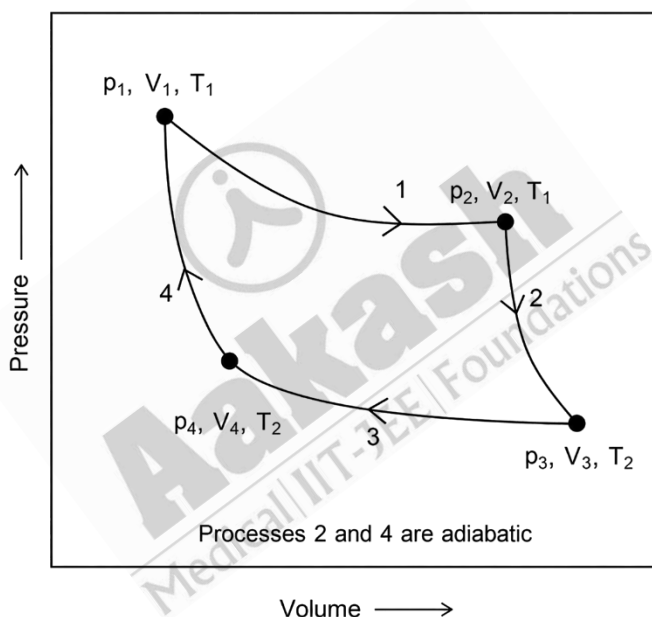

$w_1, w_2, w_3$  and  $w_4$  represent work done (in calories) in the processes 1, 2, 3 and 4, respectively;  $\Delta U_2$  and  $\Delta U_4$  are changes in the internal energy for the processes 2 and 4, respectively.

[use  $R = 2 \text{ cal K}^{-1} \text{ mol}^{-1}$ ]

The correct option is

- (1)  $w_1 + w_3 = -2T_1 \ln \frac{V_2}{V_1} - 2T_2 \ln \frac{V_4}{V_3}$   
(2)  $w_2 + w_4 = \Delta U_2 - \Delta U_4$   
(3)  $w_1 + w_2 = 2T_1 \ln \frac{V_2}{V_1}$   
(4)  $w_1 + w_2 + w_3 + w_4 = 0$

**Answer (1)**

70. Given below are two statements: One is labelled as **Assertion A** and the other is labelled as **Reason R**.

**Assertion A:** The first ionization enthalpy of O is lower than that of N and F.

**Reason R:** The loss of an electron from O leads to stable half-filled *p* orbital

In light of the above statements, choose the **most appropriate** answer from the options given below:

- (1) Both **A** and **R** are correct and **R** is the correct explanation of **A**
- (2) Both **A** and **R** are correct and **R** is **NOT** the correct explanation of **A**
- (3) **A** is correct but **R** is not correct.
- (4) **A** is not correct but **R** is correct

**Answer (1)**

71. Consider the following statements about the solutions formed by mixing two liquids.

A. An ideal solution thus formed obeys Raoult's law throughout the composition range.

B. Mixture of chloroform and acetone shows negative deviation from Raoult's law.

C. Mixture of aniline and phenol shows positive deviation from Raoult's law.

- (1) A and B only
- (2) B and C only
- (3) A only
- (4) A and C only

**Answer (1)**

72. One of the products formed in the following reaction is

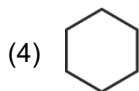
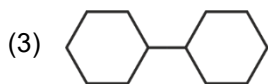
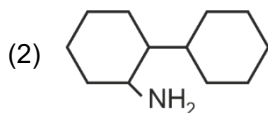
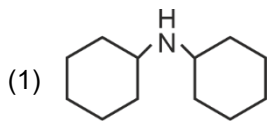
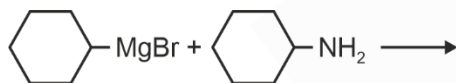

**Answer (4)**

73. The correct statement is

- (1) Boron has a maximum covalency of four.
- (2) Beryllium has three valence orbitals.
- (3) Magnesium has a maximum covalency of four.
- (4) Aluminium has five valence orbitals.

**Answer (1)**

74. A protein undergoes reversible thermal denaturation from its initial state **N** to denatured state **D** according to  $N \rightleftharpoons D$ . At 60°C, the concentrations of both **N** and **D** are equal at equilibrium, and the standard enthalpy change of denaturation is 666 kJ mol<sup>-1</sup>. The standard entropy change ( $\Delta S^\circ$  in kJ K<sup>-1</sup> mol<sup>-1</sup>) of the protein upon denaturation at 60°C is closest to

- (1) 2.0 (2) 2000.0  
(3) 333.0 (4) 11.1

**Answer (1)**

75. Match the species in **List-I** with their geometry in **List-II**.

	List-I		List-II
A.	PCl <sub>5</sub>	I.	Tetrahedral
B.	BrF <sub>5</sub>	II.	Square Planar
C.	BF <sub>4</sub> <sup>-</sup>	III.	Trigonal bipyramidal
D.	[Ni(CN) <sub>4</sub> ] <sup>2-</sup>	IV.	Square pyramidal

Choose the **correct** answer from the options given below:

- (1) A-IV, B-III, C-I, D-II (2) A-III, B-IV, C-I, D-II  
(3) A-III, B-I, C-II, D-IV (4) A-III, B-II, C-I, D-IV

**Answer (2)**

76. Given below are two statements :

**Statement I** : *trans*-But-2-ene upon treatment with Br<sub>2</sub> in CCl<sub>4</sub> gives the following product.

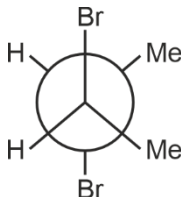

**Statement II** : *cis*-But-2-ene upon treatment with alkaline KMnO<sub>4</sub> gives the following product.

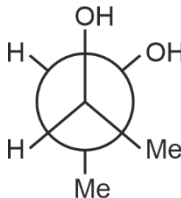

In the light of the above statements, choose the **most appropriate** answer from the options given below.

- (1) Both **Statement I** and **Statement II** are correct  
(2) Both **Statement I** and **Statement II** are incorrect  
(3) **Statement I** is correct but **Statement II** is incorrect  
(4) **Statement I** is incorrect but **Statement II** is correct

**Answer (4)**

77. Consider the following reaction sequences and choose the correct option.

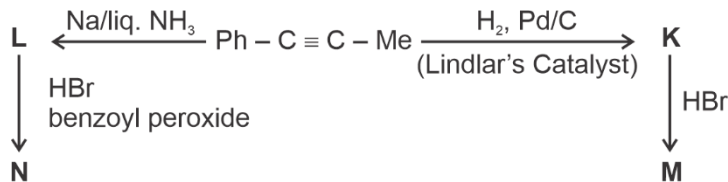

- (1) **K** and **L** are geometrical isomers
- (2) **K** and **L** are enantiomers
- (3) **M** and **N** are geometrical isomers
- (4) **M** and **N** are stereoisomers

**Answer (1)**

**Sol.**

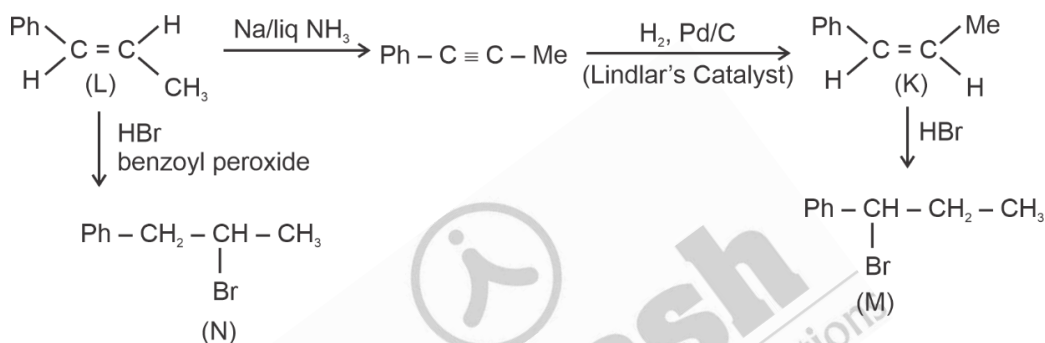

78. The complex which has *facial* and *meridional* isomers is  
 (Given : py = pyridine and en = H<sub>2</sub>N – CH<sub>2</sub> – CH<sub>2</sub> – NH<sub>2</sub>)

- (1) [Cr(py)<sub>3</sub>(Cl)<sub>3</sub>]
- (2) [Cr(H<sub>2</sub>O)<sub>6</sub>]<sup>3+</sup>
- (3) [Co(NH<sub>3</sub>)<sub>4</sub>(H<sub>2</sub>O)<sub>2</sub>]<sup>3+</sup>
- (4) [Ni(en)<sub>2</sub>(H<sub>2</sub>O)<sub>2</sub>]<sup>2+</sup>

**Answer (1)**

79. Identify the reactions which give aniline as the major product.

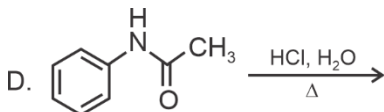
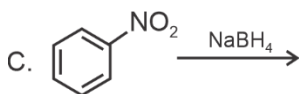
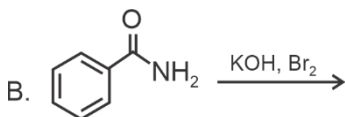
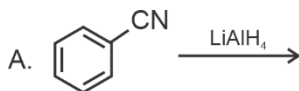

Choose the correct answer from the options given below.

- (1) A and B only (2) B and D only  
(3) A and C only (4) C and D only

**Answer (2)**

80. Match the vitamins in **List I** with their sources in **List II**

	List I		List II
A.	vitamin A	I.	meat
B.	vitamin B <sub>12</sub>	II.	sunflower oil
C.	vitamin E	III.	green leafy vegetables
D.	vitamin K	IV.	carrots

Choose the correct answer from the options given below.

- (1) A-II, B-III, C-IV, D-I (2) A-IV, B-I, C-II, D-III  
(3) A-IV, B-II, C-I, D-III (4) A-III, B-I, C-IV, D-II

**Answer (2)**

81. The correct decreasing order of oxidation state of the underlined atom in each molecule is

- (1)  $\underline{P}_4O_{10} > \underline{S}O_3 > \underline{H}_2O$  (2)  $\underline{N}_2O_5 > \underline{Al}_2O_3 > \underline{H}_2S$   
(3)  $\underline{Pb}O_2 > \underline{N}_2O_3 > \underline{SO}_3$  (4)  $\underline{P}_4O_6 > \underline{Cl}_2O_7 > \underline{Al}H_3$

**Answer (2)**

82. The compound that **CANNOT** be obtained from the aldol condensation reaction shown below, is

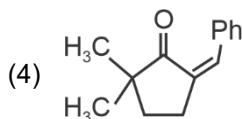
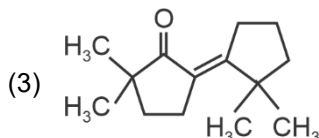
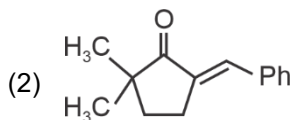
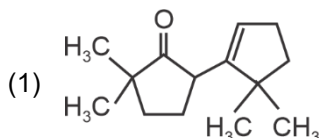
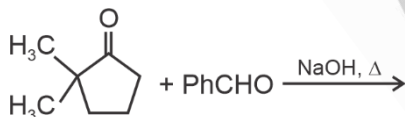

**Answer (1)**



88. Consider the following schematic plots of orbital wavefunction ( $\psi_r$ ) against distance ( $r$ ) from the nucleus.

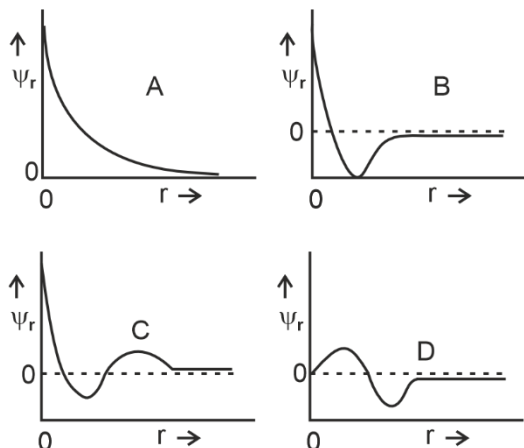

The figure representing two radial nodes in the orbital is

- (1) A
- (2) B
- (3) C
- (4) D

**Answer (3)**

89. Arrange the following compounds in the increasing order of polarity

- A.  $\text{CH}_3\text{CH}_2\text{OCH}_2\text{CH}_3$
- B.  $\text{CH}_3\text{CH}_2\text{OH}$
- C.  $\text{CH}_3\text{COCH}_3$
- D.  $\text{CH}_3\text{COOH}$

Choose the correct answer from the options given below.

- (1)  $A < B < C < D$
- (2)  $C < A < D < B$
- (3)  $C < A < B < D$
- (4)  $A < C < B < D$

**Answer (4)**

90. The highest occupied molecular orbital for  $\text{Ne}_2$  is

- (1)  $\pi_{2p}$
- (2)  $\sigma_{2p}$
- (3)  $\pi_{2p}^*$
- (4)  $\sigma_{2p}^*$

**Answer (4)**

**BIOLOGY**

91. The number of vertebrae in a human is \_\_\_\_\_.

- (1) 7
- (2) 12
- (3) 26
- (4) 206

**Answer (3)**

92. Symbiotic association between fungi and algae are called \_\_\_\_\_.

- (1) lichens
- (2) sponges
- (3) mycorrhiza
- (4) chrysophytes

**Answer (1)**

93. Cell theory was formulated by \_\_\_\_\_.

- (1) Schleiden and Schwann
- (2) Robert Brown
- (3) Singer and Nicolson
- (4) Antonie Von Leeuwenhoek

**Answer (1)**

94. Which of the following are characteristics of prokaryotic cells?

- (a) Ribosomes are made of 50S and 30S subunits
- (b) They can have plasmids
- (c) They contain mesosome
- (d) They have peroxisomes

Choose the **correct** answer from the options given below :

- (1) (b) and (c) only
- (2) (a) and (c) only
- (3) (a), (c) and (d) only
- (4) (a), (b) and (c) only

**Answer (4)**

95. Which of the following is **not** a part of human central neural system?

- (1) Arachnoid
- (2) Dura mater
- (3) Pia mater
- (4) Pericardium

**Answer (4)**

96. Mitochondrial inner membrane encloses \_\_\_\_\_ .

- (1) matrix
- (2) cytosol
- (3) mucus
- (4) aqueous humor

**Answer (1)**

97. Match **List-I** with **List-II**.

	List-I		List-II
A.	Cristae	I.	Flat membrane sacs in stroma of chloroplast
B.	Cisternae	II.	Infoldings in mitochondria
C.	Thylakoids	III.	Cell membrane
D.	Phospholipid	IV.	Disc shaped sacs in the Golgi apparatus

Choose the **correct** answer from the options given below:

- (1) A-III, B-IV, C-I, D-II
- (2) A-II, B-IV, C-I, D-III
- (3) A-II, B-IV, C-III, D-I
- (4) A-IV, B-III, C-I, D-II

**Answer (2)**

98. The plastid that stores xanthophyll is known as \_\_\_\_\_.

- (1) chloroplast
- (2) chromoplast
- (3) aleuroplast
- (4) amyloplast

**Answer (2)**

99. Which of the following statements related to pituitary gland are **correct**?

- (a) It is divided anatomically into adenohypophysis and neurohypophysis
- (b) It secretes follicle stimulating hormone
- (c) It secretes melanocyte stimulating hormone
- (d) It does not secrete prolactin

Choose the **correct** answer from the options given below :

- (1) (a) and (b) only
- (2) (a), (b) and (c) only
- (3) (c) and (d) only
- (4) (b) and (c) only

**Answer (2)**

100. Photorespiration reaction catalyzed by RuBisCo is shown below:



Identify "X" from the given options:

- (1) Phosphoenolpyruvate
- (2) 2-Phosphoglycolate
- (3) Oxaloacetate
- (4) Malate

**Answer (2)**

101. Mad cow disease is caused by \_\_\_\_\_.

- (1) prions
- (2) viroids
- (3) *Aspergillus sp.*
- (4) *Mycoplasma sp.*

**Answer (1)**

102. Which pigment has absorption peak at 700 nm in the photosynthetic reaction centre PS I (P700)?

- (1) Chlorophyll b
- (2) Chlorophyll a
- (3) Xanthophylls
- (4) Carotenoids

**Answer (2)**

103. In water, frogs respire using \_\_\_\_\_.

- (1) skin
- (2) buccal cavity
- (3) lungs
- (4) trachea

**Answer (1)**

104. Which of the following represents the correct sequence of arrangement of bones in the lower limb of humans?

- (1) Femur-tibia-patella-tarsal
- (2) Patella-femur-tibia-tarsal
- (3) Femur-patella-tibia-tarsal
- (4) Femur-tarsal-patella-tibia

**Answer (3)**

105. Phyllotaxy is the pattern of arrangement of \_\_\_\_\_.

- |            |             |
|------------|-------------|
| (1) leaves | (2) flowers |
| (3) fruits | (4) sepals  |

**Answer (1)**

106. Match List-I with List-II.

	List-I		List-II
A.	Starch	I.	Fights infection
B.	Antibody	II.	Energy storage
C.	Concanavalin A	III.	Glucose transport
D.	Glut-4	IV.	Lectin

Choose the **correct** answer from the options given below :

- (1) A-I, B-II, C-IV, D-III
- (2) A-II, B-I, C-IV, D-III
- (3) A-II, B-I, C-III, D-IV
- (4) A-I, B-II, C-III, D-IV

**Answer (2)**

107. Given below are two statements :

**Statement I** : When any plane passing through the central axis of the body divides the organism into two identical halves, it is called radial symmetry.

**Statement II** : In phylum Echinodermata, both adults and larvae are radially symmetrical.

In the light of the above statements, choose the **most appropriate** answer from the options given below :

- (1) Both **Statement I** and **Statement II** are correct
- (2) Both **Statement I** and **Statement II** are incorrect
- (3) **Statement I** is correct but **Statement II** is incorrect
- (4) **Statement I** is incorrect but **Statement II** is correct

**Answer (3)**

108. Endomembrane system includes \_\_\_\_\_.

- (1) endoplasmic reticulum, Golgi complex, lysosomes and vacuole
- (2) endoplasmic reticulum, chloroplast, peroxisomes and vacuole
- (3) mitochondria, chloroplast, peroxisomes and vacuole
- (4) Golgi complex, chloroplast, peroxisomes and vacuole

**Answer (1)**

109. How many molecules of pyruvic acid are produced at the end of glycolysis from 206 molecules of glucose?

- (1) 206
- (2) 309
- (3) 103
- (4) 412

**Answer (4)**

110. Which of the following plant growth regulators is used as herbicide?

- (1) 2, 4-D
- (2) Kinetin
- (3) Abscisic acid
- (4) Gibberellin

**Answer (1)**

111. Given below are two statements:

**Statement I:** In gymnosperms, the male and female gametophytes remain within the sporangia.

**Statement II:** In gymnosperms, seeds are not covered.

In the light of the above statements, choose the **most appropriate** answer from the options given below:

- (1) Both **Statement I** and **Statement II** are correct
- (2) Both **Statement I** and **Statement II** are incorrect
- (3) **Statement I** is correct but **Statement II** is incorrect
- (4) **Statement I** is incorrect but **Statement II** is correct

**Answer (1)**

112. Match **List-I** with **List-II**.

	<b>List-I</b>		<b>List-II</b>
A.	Spherical	I.	Vibrio
B.	Rod	II.	Cocci
C.	Comma	III.	Spirilla
D.	Spirillum	IV.	Bacilli

Choose the **correct** answer from the options given below :

- (1) A-I, B-III, C-II, D-IV
- (2) A-III, B-II, C-I, D-IV
- (3) A-II, B-I, C-IV, D-III
- (4) A-II, B-IV, C-I, D-III

**Answer (4)**

113. Which of the following are characteristic features of Solanaceae family?

- (a) Flowers are bisexual and actinomorphic
- (b) Calyx have five sepals and are united
- (c) Androecium have five stamens and are epipetalous
- (d) Ovary is inferior

Choose the **correct** answer from the options given below :

- (1) (a), (b) and (c) only
- (2) (d) only
- (3) (a) and (b) only
- (4) (b), (c) and (d) only

**Answer (1)**

114. Select the correct sequence of experiments that led to a gradual understanding of photosynthesis in green plants.
- (1) Absorption spectra of chlorophyll a and b → production of glucose → release of oxygen → role of air
  - (2) Role of air → release of oxygen → production of glucose → absorption spectra of chlorophyll a and b
  - (3) Release of oxygen → production of glucose → absorption spectra of chlorophyll a and b → role of air
  - (4) Production of glucose → role of air → release of oxygen → absorption spectra of chlorophyll a and b

**Answer (2)**

115. The number of action potentials generated by sino-atrial node (SAN) in a healthy human is \_\_\_\_\_ per minute.
- (1) 28 - 30
  - (2) 70 – 75
  - (3) 100 - 110
  - (4) 120 - 140

**Answer (2)**

116. How many turns of Calvin cycle are required for the formation of three molecules of glucose?
- (1) 6
  - (2) 3
  - (3) 1
  - (4) 18

**Answer (4)**

117. Which of the following statements is **incorrect**?
- (1) Blood coagulates in response to an injury
  - (2) Blood clot consists of fibrins
  - (3) Fibrin is produced from fibrinogen
  - (4) Fibrinogen is produced from fibrin

**Answer (4)**

118. Match **List-I** with **List-II**.

	List-I		List-II
A.	Family	I.	Sapindales
B.	Genus	II.	Dicotyledonae
C.	Class	III.	Anacardiaceae
D.	Phylum	IV.	Angiospermae
E.	Order	V.	<i>Mangifera</i>

Choose the **correct** answer from the options given below :

- (1) A-I, B-V, C-II, D-IV, E-III
- (2) A-II, B-I, C-III, D-IV, E-V
- (3) A-II, B-III, C-V, D-I, E-IV
- (4) A-III, B-V, C-II, D-IV, E-I

**Answer (4\*) (Conceptual errata)**

119. Arrange the following taxonomic categories in ascending order.

- |             |             |
|-------------|-------------|
| (a) Genus   | (b) Class   |
| (c) Order   | (d) Phylum  |
| (e) Family  | (f) Kingdom |
| (g) Species |             |

Choose the **correct** answer from the options given below :

- (1) (g), (a), (e), (c), (b), (d), (f)
- (2) (a), (c), (d), (g), (f), (b), (e)
- (3) (g), (c), (d), (b), (e), (a), (f)
- (4) (f), (c), (b), (g), (d), (e), (a)

**Answer (1)**

120. Match **List-I** with **List-II**.

	<b>List-I</b>		<b>List-II</b>
A.	Marginal placentation	I.	<i>Argemone</i>
B.	Axile placentation	II.	Tomato
C.	Parietal placentation	III.	<i>Primrose</i>
D.	Free central placentation	IV.	Pea

Choose the **correct** answer from the options given below :

- (1) A-II, B-IV, C-I, D-III
- (2) A-IV, B-II, C-III, D-I
- (3) A-IV, B-III, C-I, D-II
- (4) A-IV, B-II, C-I, D-III

**Answer (4)**

121. Sphenopsida class belongs to \_\_\_\_\_.

- (1) bryophytes
- (2) angiosperms
- (3) gymnosperms
- (4) pteridophytes

**Answer (4)**

122. Which of the following statements regarding photorespiration are correct?
- (a) Do not occur in C<sub>3</sub> plants
  - (b) CO<sub>2</sub> is consumed and O<sub>2</sub> is generated
  - (c) Phosphoglycolate is formed
  - (d) No synthesis of ATP and NADPH

Choose the **correct** answer from the options given below:

- (1) (a) and (d) only
- (2) (c) and (d) only
- (3) (b) and (d) only
- (4) (a) and (b) only

**Answer (2)**

123. Smooth endoplasmic reticulum \_\_\_\_\_ .
- (1) has ribosomes attached to its surface
  - (2) is the major site for the synthesis of lipids
  - (3) is actively involved in protein synthesis
  - (4) is a site for the synthesis of carbohydrates

**Answer (2)**

124. Which one of the following statements is **incorrect**?
- (1)  $\alpha$ -cells of pancreas secrete glucagon
  - (2)  $\alpha$ -cells of pancreas secrete insulin
  - (3) Glucagon stimulates glycogenolysis
  - (4)  $\beta$ -cells of pancreas secrete insulin

**Answer (2)**

125. Genus represents \_\_\_\_\_.
- (1) an individual plant or animal
  - (2) a population of plants and animals
  - (3) a group of closely related species
  - (4) a group of closely related families

**Answer (3)**

126. Which of the following is **not** a prokaryote?
- (1) Bacteria
  - (2) Blue green algae
  - (3) Mycoplasma
  - (4) Fungi

**Answer (4)**

127. Which of the following plant growth regulators promotes internode elongation prior to flowering in cabbage?
- (1) Abscisic acid
  - (2) Gibberellin
  - (3) Indole butyric acid
  - (4) Ethephon

**Answer (2)**

128. The correct sequence of adult cell cycle phases is \_\_\_\_\_.
- (1) G1-G2-S-M
  - (2) G1-M-G2-S
  - (3) G1-S-G2-M
  - (4) S-M-G2-G1

**Answer (3)**

129. Match **List-I** with **List-II**.

	<b>List-I</b>		<b>List-II</b>
A.	Fusion of protoplasts between gametes	I.	Meiosis
B.	Fusion of two nuclei	II.	Plasmogamy
C.	Generation of haploid spores	III.	Karyogamy

Choose the **correct** answer from the options given below :

- (1) A-II, B-III, C-I
- (2) A-II, B-I, C-III
- (3) A-III, B-II, C-I
- (4) A-I, B-III, C-II

**Answer (1)**

130. Given below are two statements:

**Statement I** : The class name Reptilia refers to creeping or crawling mode of locomotion.

**Statement II** : All organisms belonging to Reptilia have three chambered heart.

In the light of the above statements, choose the **most appropriate** answer from the options given below:

- (1) Both **Statement I** and **Statement II** are correct
- (2) Both **Statement I** and **Statement II** are incorrect
- (3) **Statement I** is correct but **Statement II** is incorrect
- (4) **Statement I** is incorrect but **Statement II** is correct

**Answer (3)**

131. Given below are two statements :

**Statement I** : Chromosomes are fully condensed at the end of prophase I.

**Statement II** : Meiosis I resembles mitosis.

In the light of the above statements, choose the **most appropriate** answer from the options given below :

- (1) Both **Statement I** and **Statement II** are true
- (2) Both **Statement I** and **Statement II** are false
- (3) **Statement I** is correct, but **Statement II** is false
- (4) **Statement I** is incorrect, but **Statement II** is true

**Answer (3)**

132. Which of the following is **not** a characteristic of chordates?

- (1) Presence of notochord
- (2) Central nervous system is dorsal
- (3) Absence of gills
- (4) Presence of post anal part (tail)

**Answer (3)**

133. Length of the stem at time 0 is 20 cm. The arithmetic growth rate is 30 cm per day. What is the length of the stem at the end of the 7<sup>th</sup> day?

- (1) 50 cm
- (2) 170 cm
- (3) 230 cm
- (4) 460 cm

**Answer (3)**

134. Arrange the following elements in descending order of their contribution to percentage weight of the human body.

- (a) Oxygen
- (b) Carbon
- (c) Hydrogen
- (d) Nitrogen

Choose the **correct** answer from the options given below :

- (1) (a), (b), (c), (d)
- (2) (c), (a), (b), (d)
- (3) (b), (c), (d), (a)
- (4) (b), (a), (c), (d)

**Answer (1)**

135. In frogs, the number of pairs of cranial nerves arising from the brain are \_\_\_\_\_.

- |        |        |
|--------|--------|
| (1) 6  | (2) 9  |
| (3) 10 | (4) 12 |

**Answer (3)**

136. Which of the following is used as a clot buster?

- (1) Streptokinase (2) Penicillin  
(3) Cyclosporin A (4) Statins

**Answer (1)**

137. The inactive form of Bt toxin is converted to the active form in the insect gut \_\_\_\_\_

- (1) due to alkaline pH  
(2) due to acidic pH  
(3) by proteases  
(4) by nucleases

**Answer (1)**

138. Given below are two statements :

**Statement I** : Down's syndrome is caused by the absence of one of the X-chromosomes.

**Statement II** : Turner's syndrome is caused by the presence of an additional copy of the chromosomes.

In the light of the above statements, choose the **correct** answer from the options given below :

- (1) Both **Statement I** and **Statement II** are correct  
(2) Both **Statement I** and **Statement II** are incorrect  
(3) **Statement I** is correct but **Statement II** is incorrect  
(4) **Statement I** is incorrect but **Statement II** is correct

**Answer (2)**

139. Which of the following disease is **not** sexually transmitted?

- (1) Syphilis (2) Tuberculosis  
(3) Gonorrhoea (4) Genital warts

**Answer (2)**

140. Sperm motility is due to \_\_\_\_\_.

- (1) flagellar movement  
(2) ciliary movement  
(3) amoeboid movement  
(4) muscular movement

**Answer (1)**

141. Natural selection can lead to \_\_\_\_\_.

- (a) stabilisation (b) genetic drift  
(c) directional change (d) disruption

Choose the **correct** answer from the options given below :

- (1) (a) only (2) (a), (c) and (d) only  
(3) (a), (b), (c) and (d) (4) (a) and (c) only

**Answer (2)**

142. The method of directly of injecting a sperm into ovum in assisted reproductive technology is called :
- (1) Gamete intra fallopian transfer (GIFT)
  - (2) Zygote intra fallopian transfer (ZIFT)
  - (3) Intra cytoplasmic sperm injection (ICSI)
  - (4) Embryo transfer (ET)

**Answer (3)**

143. Which of the following struture is **not** a part of the male reproductive system?
- (1) Rete testis
  - (2) Epididymis
  - (3) Vasa efferentia
  - (4) Infundibulum

**Answer (4)**

144. Arrange the following in descending order of number of species in the Amazonian rain forest.
- (a) Plants
  - (b) Birds
  - (c) Fishes
  - (d) Invertebrates
  - (e) Mammals

Choose the **correct** answer from the options given below :

- (1) (c) > (b) > (d) > (e) > (a)
- (2) (d) > (a) > (c) > (b) > (e)
- (3) (e) > (b) > (a) > (c) > (d)
- (4) (b) > (a) > (d) > (c) > (e)

**Answer (2)**

145. Given below are two statements:

**Statement I** : Ovulation is caused by LH surge leading to rupture of Graafian follicles.

**Statement II**: Graafian follicle remaining after ovulation transform into corpus luteum and secretes large amount of estrogen.

In the light of the above statements, choose the **most appropriate** answer from the options given below:

- (1) Both **Statement I** and **Statement II** are correct
- (2) Both **Statement I** and **Statement II** are incorrect
- (3) **Statement I** is correct but **Statement II** is incorrect
- (4) **Statement I** is incorrect but **Statement II** is correct

**Answer (3)**

146. Which of the following are primary consumers in a food chain?

- (1) Parasites
- (2) Predators
- (3) Herbivores
- (4) Carnivores

**Answer (3)**

147. A population of diploid organisms is at Hardy-Weinberg equilibrium. If the frequency of allele A is 0.1, the frequency of AA is \_\_\_\_\_.

- (1) 0.01 (2) 0.02  
(3) 0.10 (4) 0.99

**Answer (1)**

148. Match **List-I** with **List-II**.

- | <b>List-I</b>             | <b>List-II</b>                                       |
|---------------------------|--|
| (A) Excess growth hormone | (I) Reabsorption of water and electrolytes in kidney |
| (B) Luteinizing hormone   | (II) Contraction of uterus during child birth        |
| (C) Vasopressin           | (III) Acromegaly                                     |
| (D) Oxytocin              | (IV) Ovulation                                       |

Choose the **correct** answer from the options given below:

- (1) A-III, B-IV, C-II, D-I  
(2) A-III, B-IV, C-I, D-II  
(3) A-II, B-IV, C-I, D-III  
(4) A-IV, B-III, C-I, D-II

**Answer (2)**

149. The opening between the right atrium and the right ventricle is guarded by \_\_\_\_\_.

- (1) bicuspid valve (2) tricuspid valve  
(3) semilunar valve (4) sino-atrial node

**Answer (2)**

150. Sponges exchange  $O_2$  with  $CO_2$  by \_\_\_\_\_.

- (1) simple diffusion over their entire body surfaces  
(2) moist cuticle  
(3) tracheal tubes  
(4) gills

**Answer (1)**

151. How many theca are present in each lobe of a typical bilobed angiosperm anther ?

- (1) 2 (2) 6  
(3) 8 (4) 12

**Answer (1)**

152. Muscle contraction is initiated by a signal sent by the central nervous system by the release of \_\_\_\_\_.

- (1) acetyl choline  
(2) acetyl coenzyme A  
(3) cyclic guanine monophosphate  
(4) cyclic adenine monophosphate

**Answer (1)**

153. Which of the following statements about lac-operon is **correct**?

- (1) Gene *i* is constitutively expressed
- (2) Lactose activates repressor to bind to the operator
- (3) Genes *i*, *z*, *y* and *a* share single common promoter
- (4) Galactose can act as an inducer of lac operon

**Answer (1)**

154. Which of the following in female gametophyte of an angiosperm helps in guiding the pollen tube for fertilizing the eggs?

- |                   |                   |
|-------------------|-------------------|
| (1) Antipodals    | (2) Synergids     |
| (3) Central cells | (4) Polar nucleus |

**Answer (2)**

155. Which of the following plant produces non-albuminous seeds?

- |            |           |
|------------|-----------|
| (1) Wheat  | (2) Maize |
| (3) Barley | (4) Pea   |

**Answer (4)**

156. If the diploid chromosome number of typical angiosperm is 36, what would be the chromosome number in its endosperm?

- |        |        |
|--------|--------|
| (1) 18 | (2) 36 |
| (3) 54 | (4) 72 |

**Answer (3)**

157. Which of the following statements about the reabsorption process in Henle's loop are **correct**?

- (a) The descending limb of Henle's loop is permeable to water but almost impermeable to electrolytes.
- (b) Urine gets concentrated in Henle's loop.
- (c) Reabsorption of  $\text{Na}^+$  and water takes place in Henle's loop.
- (d) Active or passive transport of electrolytes occurs in the ascending limb of Henle's loop.

Choose the **correct** answer from the options given below:

- (1) (a) and (b) only
- (2) (b), (c) and (d) only
- (3) (a), (b) and (c) only
- (4) (a), (b) and (d) only

**Answer (\*)**

158. Which of the following is the **correct** order of arrangement of vertebrate column from the head to toe?

- (1) Cervical vertebra, thoracic vertebra, sacrum, lumbar vertebra
- (2) Sacrum, lumbar vertebra, thoracic vertebra, cervical vertebra
- (3) Cervical vertebra, lumbar vertebra, thoracic vertebra, sacrum
- (4) Cervical vertebra, thoracic vertebra, lumbar vertebra, sacrum

**Answer (4)**

159. Which of the following is **not** evidence for evolution?
- (1) Convergent evolution of traits like wings of birds and butterflies
  - (2) Paleontological evidence from fossil records
  - (3) Embryological support for evolution as proposed by Ernst Heckel
  - (4) Divergent evolution of anatomical structures such as forelimbs

**Answer (1/3\*)**

160. Given below are two statements :

**Statement I** : Modern *Homo sapiens* arose in Australia and moved across continents.

**Statement II** : *Homo sapiens* arose around 75000 to 10000 years ago.

In the light of the above statements, choose the **most appropriate** answer from the options given below :

- (1) Both **Statement I** and **Statement II** are correct
- (2) Both **Statement I** and **Statement II** are incorrect
- (3) **Statement I** is correct but **Statement II** is incorrect
- (4) **Statement I** is incorrect but **Statement II** is correct

**Answer (4)**

161. Consider a population of 10 million cells. Given the per-capita birth rate of 0.002 (per unit time) and the per-capita death rate of 0.002 (per unit time), the expected number of cells after 10 generations is \_\_\_\_\_.

- (1) 1 million
- (2) 5 million
- (3) 10 million
- (4) 100 million

**Answer (3)**

162. During PCR, primers bind to the DNA strands in the \_\_\_\_\_ step.

- (1) denaturation
- (2) extension
- (3) annealing
- (4) ligation

**Answer (3)**

163. Given below are two statements : one is labelled as **Assertion A** and the other is labelled as **Reason R**.

**Assertion A** : The logistic growth model of populations is considered more realistic than the exponential growth model.

**Reason R** : Resources are finite.

In the light of the above statements, choose the **most appropriate** answer from the options given below :

- (1) Both **A** and **R** are correct and **R** is the correct explanation of **A**
- (2) Both **A** and **R** are correct but **R** is not the correct explanation of **A**
- (3) **A** is correct but **R** is not correct
- (4) **A** is not correct but **R** is correct

**Answer (1)**

164. Adaptive radiation in placental mammals and Australian Marsupials leading to similarity between distant species is an example of \_\_\_\_\_.
- (1) divergent evolution (2) convergent evolution  
(3) founder effect (4) genetic drift

**Answer (2)**

165. Which of the following are secondary lymphoid organs?
- (a) Bone marrow (b) Tonsils  
(c) Spleen (d) Thymus
- Choose the **correct** answer from the options given below:
- (1) (a) and (b) only (2) (b) and (c) only  
(3) (b) and (d) only (4) (a) and (d) only

**Answer (2)**

166. Which of the following hormone is **not** secreted by human placenta?
- (1) hCG (2) Estrogen  
(3) Progesterone (4) LH

**Answer (4)**

167. Which of the following enzymes synthesizes precursor mRNA?
- (1) RNA polymerase I (2) RNA polymerase II  
(3) RNA polymerase III (4) DNA polymerase

**Answer (2)**

**Sol.** The RNA polymerase II transcribes precursor of mRNA, the heterogeneous nuclear RNA (hnRNA)

168. Given below are two statements :

**Statement I** : Plasmids are autonomously replicating DNA.

**Statement II** : Plasmids are extrachromosomal DNA.

In the light of the above statements, choose the **most appropriate** answer from the options given below :

- (1) Both **Statement I** and **Statement II** are correct  
(2) Both **Statement I** and **Statement II** are incorrect  
(3) **Statement I** is correct but **Statement II** is incorrect  
(4) **Statement I** is incorrect but **Statement II** is correct

**Answer (1)**

169. For a person with blood group 'O', which of the following is **not** a possible combination of parents' blood group genotypes?
- (1) Father :  $I^A i$  and Mother :  $I^B i$   
(2) Father :  $I^A i$  and Mother :  $I^A i$   
(3) Father :  $I^B i$  and Mother :  $I^B i$   
(4) Father :  $I^A I^B$  and Mother :  $I^A i$

**Answer (4)**

170. Given below are two statements : one is labelled as **Assertion A** and the other is labelled as **Reason R**.

**Assertion A** : Forelimbs of human and bats are homologous.

**Reason R** : Forelimbs of humans and bats have similar anatomical structure.

In the light of the above statements, choose the **most appropriate** answer from the options given below.

- (1) Both **A** and **R** are correct and **R** is the correct explanation of **A**
- (2) Both **A** and **R** are true, but **R** is not the correct explanation of **A**
- (3) **A** is true but **R** is false
- (4) **A** is false but **R** is true

**Answer (1)**

171. Colostrum, secreted by mother during initial days of lactation, is abundant in \_\_\_\_\_.

- (1) IgG
- (2) IgM
- (3) IgA
- (4) IgD

**Answer (3)**

172. Given below are two statements : one is labelled as **Assertion A** and the other is labelled as **Reason R**.

**Assertion A** : Abingdon tortoise in Galapagos islands became extinct within a decade after goats were introduced.

**Reason R** : Goats were more efficient at browsing than Abingdon tortoise.

In the light of the above statements, choose the **most appropriate** answer from the options given below:

- (1) Both **A** and **R** are correct and **R** is the correct explanation of **A**
- (2) Both **A** and **R** are correct but **R** is not the correct explanation of **A**
- (3) **A** is correct but **R** is not correct
- (4) **A** is not correct but **R** is correct

**Answer (1)**

173. The covering of ovum at ovulation is \_\_\_\_\_.

- (1) endometrium
- (2) zona radiata
- (3) zona pellucida
- (4) chorion

**Answer (3)**

174. Match **List-I** with **List-II**.

	<b>List-I</b>		<b>List-II</b>
A.	Both species are harmed	I.	Predation
B.	One species is harmed and the other is benefited	II.	Mutualism
C.	Both species are benefited	III.	Competition
D.	One is benefited while the other has no effect	IV.	Commensalism

Choose the **correct** answer from the options given below:

- (1) A-III, B-IV, C-II, D-I
- (2) A-I, B-II, C-III, D-IV
- (3) A-II, B-I, C-IV, D-III
- (4) A-III, B-I, C-II, D-IV

**Answer (4)**

175. Given below are two statements : one is labelled as **Assertion A** and the other is labelled as **Reason R**.  
**Assertion A** : In an experiment, Mendel observed that the F1 progeny plants are all tall and none are dwarf.  
**Reason R** : Stem height is a contrasting trait, with tall being dominant and dwarf being recessive.

In the light of the above statements, choose the **most appropriate** answer from the options given below :

- (1) Both **A** and **R** are correct and **R** is the correct explanation of **A**
- (2) Both **A** and **R** are correct but **R** is not the correct explanation of **A**
- (3) **A** is correct but **R** is not correct
- (4) **A** is not correct but **R** is correct

**Answer (1)**

176. Given below are two statements : one is labelled as **Assertion A** and the other is labelled as **Reason R**.  
**Assertion A** : In recombinant DNA technology, lysozyme is used for disrupting bacterial cells while cellulase is for plant cells.

**Reason R** : Isolation of genetic material needs disruption of cells.

In the light of the above statements, choose the **most appropriate** answer from the options given below :

- (1) Both **A** and **R** are correct and **R** is the correct explanation of **A**
- (2) Both **A** and **R** are correct but **R** is not the correct explanation of **A**
- (3) **A** is correct but **R** is not correct
- (4) **A** is not correct but **R** is correct

**Answer (1)**

177. Which of the following is used as an effective sedative and painkiller for treating post-surgery patients?

- (1) Interferon
- (2) Antibiotics
- (3) Morphine
- (4) Anti-retroviral drugs

**Answer (3)**

178. Which of the following statements are **Correct** ?

- (a) Energy flow from producers to consumers is unidirectional
- (b) Energy pyramid can never be inverted
- (c) Transfer of energy follows the 1% law

Choose the **correct** answer from the options given below :

- (1) (a), (b) and (c)
- (2) (a) and (b) only
- (3) (a) and (c) only
- (4) (b) and (c) only

**Answer (2)**

179. Which of the following statements is **correct** about *Plasmodium*?

- (1) Reproduces sexually in liver cells
- (2) Reproduces sexually in RBCs
- (3) Gametocytes develop in mosquito gut
- (4) Fertilization takes place in mosquito gut

**Answer (4)**

180. Match **List-I** with **List-II**.

	<b>List-I</b>		<b>List-II</b>
A.	Transformation	I.	Restriction enzyme
B.	Cloning site	II.	Transfer DNA to host bacteria
C.	Selection	III.	Replication
D.	Ori	IV.	Antibiotic

Choose the **correct** answer from the options given below:

- (1) A-II, B-I, C-IV, D-III
- (2) A-I, B-II, C-IV, D-III
- (3) A-III, B-IV, C-II, D-I
- (4) A-IV, B-I, C-III, D-II

**Answer (1)**

