

DATE: 21/06/2026

Test Booklet Code



80

SUSHRUT

Corporate Office: 3rd Floor, Incuspaze Campus-2, Plot No. 13,
Sector-18, Udyog Vihar, Gurugram, Haryana - 122015.

Questions & Answers for

Time : 3 hrs. 15 min.

M.M. : 720

NEET (UG)-2026 (Re-Examination)

Important Instructions:

1. The test is of **3 hours 15 minutes** duration and the Test Booklet contains **180** multiple choice questions (Four options with a single correct answer) from **Physics, Chemistry & Biology (Botany and Zoology)**.
2. Each question carries **4 marks**. For each correct response, the candidate will get **4 marks**. For each incorrect response, **1 mark** will be deducted from the total scores. The maximum marks are **720**.
3. Use **Blue / Black Ball Point Pen only** for writing particulars on this page / marking responses on Answer Sheet.
4. Rough work is to be done in the space provided for this purpose in the Test Booklet only.
5. On completion of the test, the candidate **must handover the Answer Sheet (original & office copy) to the Invigilator** before leaving the Room / Hall. The candidates are allowed to take away this Test Booklet with them.
6. The **CODE** for this Booklet is **80**.
7. The candidates should ensure that the Answer Sheet is not folded. Do not make any stray marks on the Answer Sheet. Do not write your Roll No. anywhere else except in the specified space in the Test Booklet/Answer Sheet. Use of white fluid for correction is **NOT** permissible on the Answer Sheet.
8. Each candidate must show on-demand his/her Admit Card to the Invigilator.
9. No candidate, without special permission of the Centre Superintendent or Invigilator, would leave his/her seat.
10. Use of Electronic/Manual Calculator is prohibited.
11. The candidates are governed by all Rules and Regulations of the examination with regard to their conduct in the Examination Hall. All cases of unfair means will be dealt with as per Rules and Regulations of this examination.
12. No part of the **Test Booklet** and **Answer Sheet** shall be detached under any circumstances.
13. The candidates will write the Correct Test Booklet Code as given in the Test Booklet / Answer Sheet in the Attendance Sheet.

PHYSICS

1. An ideal gas is made of polyatomic molecules. Each of the molecules has three translational, three rotational and f number of vibrational modes. If the ratio of heat capacities C_P/C_V of the gas is $8/7$, then the value of f is:
- (1) 3 (2) 2
(3) 1 (4) 4

Answer (4)

2. One main scale division of a Vernier calliper is equal to 1 mm and the number of divisions on the Vernier scale is 10. When both the jaws touch each other, the Vernier scale shifts to the left of zero of the main scale in such a way that 4th Vernier division coincides with a division of the main scale. If this Vernier calliper measures the length of the wire to be 1 cm, the actual length of the wire is :
- (1) 0.96 cm (2) 1.00 cm
(3) 1.04 cm (4) 0.60 cm

Answer (No option is correct)

3. Three identical p-n junction diodes D_1 , D_2 , and D_3 are connected across a battery as shown in the figure. If the width of the depletion regions of D_1 , D_2 and D_3 are W_1 , W_2 and W_3 , respectively, then the correct option is:

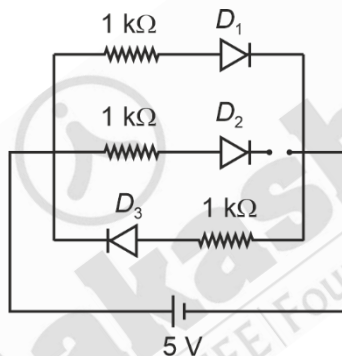

- (1) $W_3 = W_1 > W_2$ (2) $W_3 > W_2 > W_1$
(3) $W_2 > W_1 = W_3$ (4) $W_1 > W_2 > W_3$

Answer (2)

4. Consider a spring-mass simple harmonic oscillator in one dimension. The mass of the particle is m kg and the spring constant is k Nm^{-1} . At a given instant, the extension of the spring is x -meter and the speed of the particle is v ms^{-1} . On the $x - v$ plane, if the graph of v as a function of x is a circle, then the correct option is:
- (1) $k = m$ (2) $k = m^2$
(3) $k = \sqrt{m}$ (4) $k = \frac{1}{m}$

Answer (1)

5. An electromagnetic wave travelling in a lossless dielectric medium having a dielectric constant, $\epsilon_r = 9$, has the electric field, $E_x = E_0 \sin(kz - 2\pi \times 10^6 t)$ Vm^{-1} where E_0 is the amplitude and k is the wave vector. Among the following options, the **incorrect** choice is
- (1) The wavelength of the electromagnetic wave inside the medium is 300 m
(2) The magnetic field is given by the relation $B_y = \frac{B_0}{v} \sin(kz - 2\pi \times 10^6 t)$ where v is the speed of the electromagnetic wave inside the medium
(3) The direction of propagation of the electromagnetic wave is along $+z$
(4) The speed of the electromagnetic wave inside the medium is 10^8 ms^{-1}

Answer (1)

6. A frictionless circular wire of unit radius is fixed on the horizontal plane. Two-point particles of unit mass start moving simultaneously from point $A\left(\theta = \frac{\pi}{2}\right)$ with identical uniform angular speeds in opposite directions, and meet again at point $B\left(\theta = -\frac{\pi}{2}\right)$. During this time, which of the following figures schematically represent the magnitude of the total linear momentum P of the system, as a function of θ ?

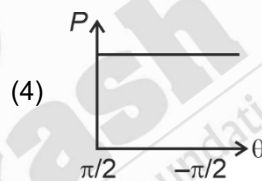
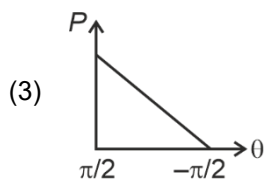
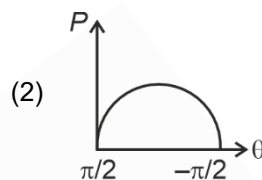
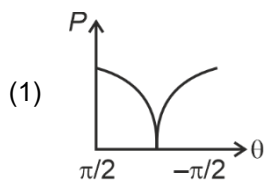
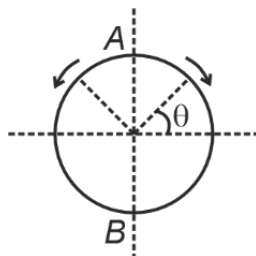

Answer (2)

7. In Geiger-Marsden experiment, the number of scattered α -particles $N(\theta)$ is plotted as a function of scattering angle θ . Which of the following options represents the correct plot?

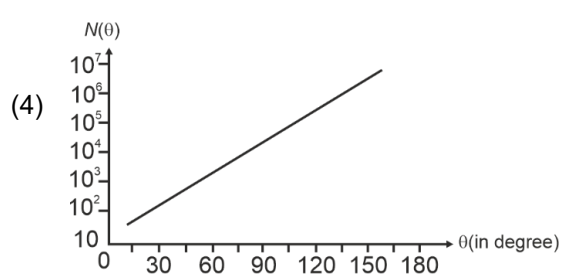
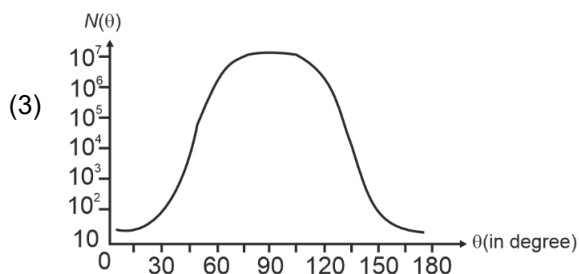
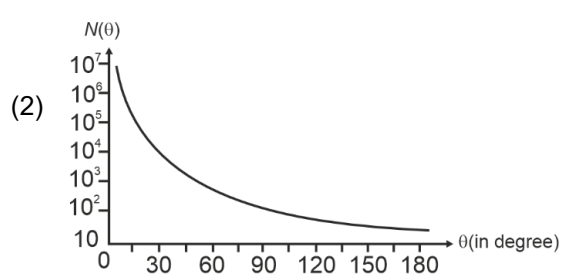
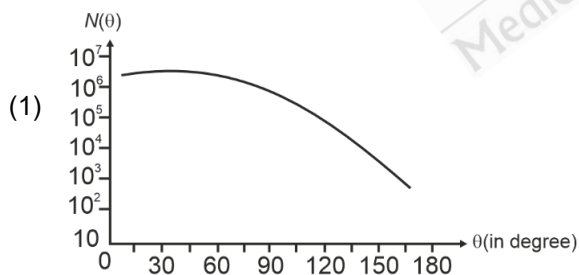

Answer (2)

8. Consider three media P , Q and R with refractive indices 1, 1.25, and 1.5 respectively. The medium Q having a thickness of 5 cm is placed between extended media P and R as shown in the figure. An object O is placed at the centre of medium Q . If viewed from medium P near the normal direction, the apparent depth of O is h_1 . For similar observation from medium R , the apparent depth is h_2 . The value of $|h_1 - h_2|$, in cm, is:

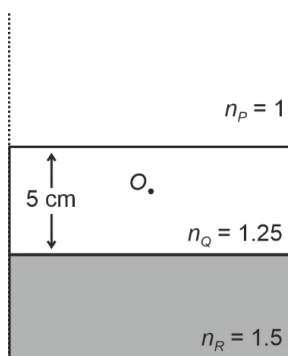

- (1) 1 (2) 2
(3) 3 (4) 0

Answer (1)

9. Consider that σ_s , k_B , b represents Stefan-Boltzmann constant, Boltzmann constant and Wien's displacement law constant, respectively. The dimension of $\sigma_s k_B^{-1} b$ is

- (1) $[L^{-1}K^{-2}]$ (2) $[L^{-1}T^{-1}K^{-3}]$
(3) $[L^{-1}T^{-1}K^{-4}]$ (4) $[L^{-1}T^{-1}K^{-2}]$

Answer (4)

10. For sound waves, if the number of nodes for the 5th harmonic of an open-ended pipe is n and that for the 9th harmonic of the same pipe with one of its ends closed is m , the ratio $\frac{n}{m}$ is

- (1) $\frac{9}{5}$ (2) 1
(3) $\frac{3}{5}$ (4) $\frac{5}{9}$

Answer (2)

11. Two infinitely long parallel conducting wires A and B carry currents I and $2I$, respectively, in the same direction. The wire A has uniform mass per unit length λ and lies on an insulated floor. The wire B is kept fixed at a height h above the floor. The minimum magnitude of h so that the wire A does not rise from the floor is:

[g is the acceleration due to gravity and μ_0 is the permeability of free space.]

- (1) $\frac{\mu_0 I^2}{\pi \lambda g}$ (2) $\frac{2\mu_0 I^2}{\pi \lambda g}$
(3) $\frac{4\mu_0 I^2}{\pi \lambda g}$ (4) $\frac{\mu_0 I^2}{2\pi \lambda g}$

Answer (1)

12. An ac voltage $V = 220 \sin(2 \times 10^3 t)$ Volt is applied to a series LCR circuit. Then the current amplitude in this circuit is:

(Given : $L = 10 \text{ mH}$, $C = 25 \text{ } \mu\text{F}$, $R = 100 \text{ } \Omega$)

- (1) 5.5 A (2) 11.0 A
(3) 22.0 A (4) 2.2 A

Answer (4)

13. Consider a fixed uniformly charged insulating sphere with radius R and total charge $+Q$. A point charge $-q$ ($q \ll Q$) with mass m is released from rest at a distance of $3R$ from the centre of the charged sphere. When the point charge reaches the surface of the sphere, its speed is:

(ϵ_0 is the permittivity of vacuum, neglect gravitational forces).

- (1) $\sqrt{\frac{2Qq}{3\pi\epsilon_0 mR}}$ (2) $\sqrt{\frac{Qq}{3\pi\epsilon_0 mR}}$
(3) $\sqrt{\frac{Qq}{4\pi\epsilon_0 mR}}$ (4) $\sqrt{\frac{3Qq}{4\pi\epsilon_0 mR}}$

Answer (2)

14. A beam of light falls on a metal surface such that photo-electrons are generated. If power of the light source starts to decrease linearly with time t , then variation of the photocurrent I and magnitude of the stopping potential $|V|$ with time is best represented by:

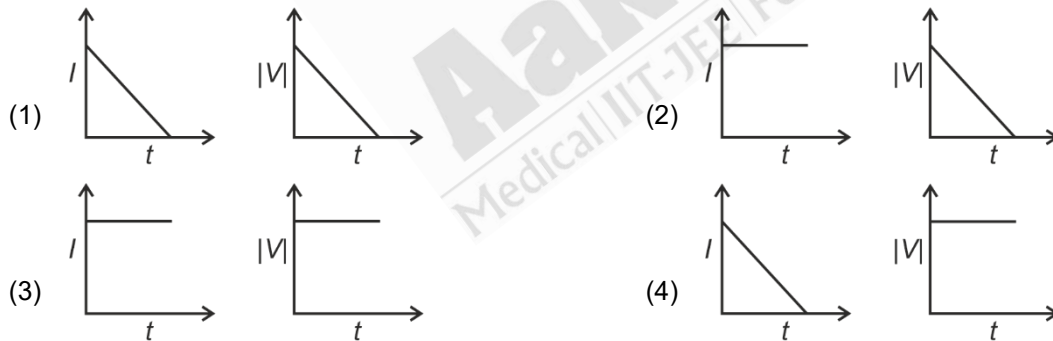

Answer (4)

15. Two planets P_1 and P_2 with equal mass have radii R_1 and R_2 , respectively, where $R_2 = \frac{R_1}{2}$. The escape

speeds of P_1 and P_2 are v_1 and v_2 , respectively. Then $\frac{v_2}{v_1}$ is:

- (1) 1 (2) $\sqrt{2}$
(3) 2 (4) $\frac{1}{\sqrt{2}}$

Answer (2)

16. A unit positive point charge is taken slowly through an infinitesimally thin tube that is inside a charged dielectric sphere of radius R , having uniform positive charge density ρ , as shown in the figure. The initial and final positions of the charge are marked by A and B at distance $2R$ and $3R$ respectively, from the centre of the sphere. In this process, the magnitude of the total work done on the point charge is $\frac{\rho R^2}{n\epsilon_0}$. The value of n is :
(ϵ_0 is the permittivity of vacuum)

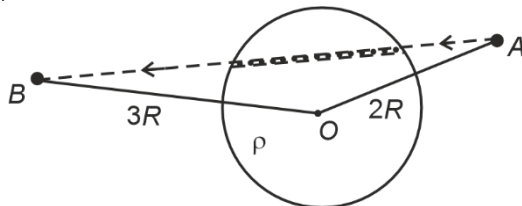

- (1) 6
(2) 9
(3) 18
(4) 2

Answer (3)

17. One mole of an ideal monatomic gas undergoes a cyclic process as shown in the figure. The total heat supplied to the gas is:

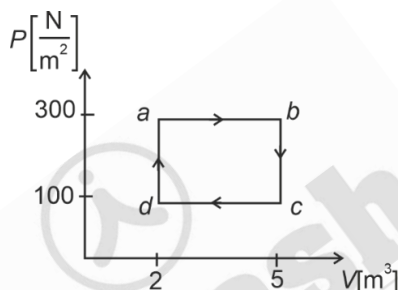

- (1) 500 J
(2) 600 J
(3) 800 J
(4) 400 J

Answer (2)

18. The following table presents the part of the electromagnetic spectrum and their corresponding major applications.

	Part of the electromagnetic spectrum		Applications
P.	Microwave	I.	For purifying the water
Q.	UV rays	II.	For warming the food
R.	Gamma rays	III.	For AM and FM communication systems
S.	Radio wave	IV.	For treating the Cancer cells

The **correct** option is:

- (1) P-I, Q-IV, R-II, S-III
(2) P-II, Q-I, R-IV, S-III
(3) P-II, Q-IV, R-III, S-I
(4) P-I, Q-II, R-III, S-IV

Answer (2)

19. A car travels on a circular racetrack of radius 50 m, which is banked at an angle θ . If the car travels at a speed 10 ms^{-1} , then the wear and tear on its tyres is minimum. Taking the acceleration due to gravity to be 10 ms^{-2} , the value of θ is:

- (1) $\tan^{-1}\left(\frac{2}{5}\right)$
(2) $\tan^{-1}(\sqrt{3}/2)$
(3) $\tan^{-1}(2\sqrt{3})$
(4) $\tan^{-1}\left(\frac{1}{5}\right)$

Answer (4)

20. Consider a particle moving along a straight line, whose position as a function of time is given by $s(t) = \alpha t^2 - \beta t + \gamma$, where $\alpha = 1 \text{ ms}^{-2}$, $\beta = 6 \text{ ms}^{-1}$ and $\gamma = 5 \text{ m}$. The average speed of the particle, in ms^{-1} from $t = 0$ to $t = 6 \text{ s}$ is:

- (1) 6 (2) 3
(3) 0 (4) 12

Answer (2)

21. A point charge Q is placed inside a cavity within a solid isolated conducting sphere. Consider points A , B and C as shown in the figure, where the magnitudes of the electric fields are E_A , E_B , E_C , respectively. The points B and C are at the same distance from the center of the solid sphere. The correct option is :

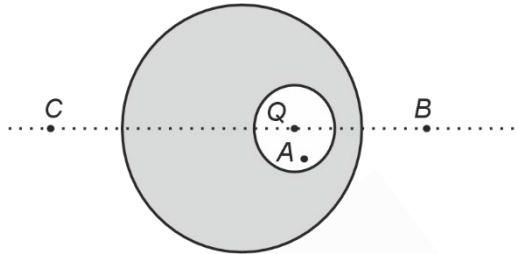

- (1) $E_A \neq 0, E_B = E_C$ (2) $E_A = 0, E_B > E_C$
(3) $E_A \neq 0, E_B < E_C$ (4) $E_A = 0, E_B = E_C$

Answer (1)

22. In the measurement of viscosity of liquids using terminal velocity experiment, spherical balls of same radius but having different densities are used. The variation of the terminal velocity (v) with the ratio of density of spherical ball (σ) to density of the liquid (ρ), is best represented by:



Answer (4)

23. A ray of light with wavelength λ is incident on three different photoelectric cells namely 1, 2 and 3. The threshold wavelength of these photoelectric cells are λ_1 , λ_2 , and λ_3 , respectively and the magnitude of stopping potentials of these cells are V_1 , V_2 and V_3 , respectively. The relation between λ and threshold wavelengths are $\lambda_1 < \lambda$, $\lambda_2 > \lambda$ and $\lambda_3 \gg \lambda$. The correct option is:

- (1) $V_1 = 0, V_2 > V_3$ (2) $V_1 > V_2, V_3 = 0$
(3) $V_1 < V_2, V_3 = 0$ (4) $V_1 = 0, V_2 < V_3$

Answer (4)

24. A current I_0 flows through a metallic circular loop of radius r as shown in the figure. Resistance of the segment ABC is half that of ADC . Magnitude of magnetic field at the centre O of the loop is :

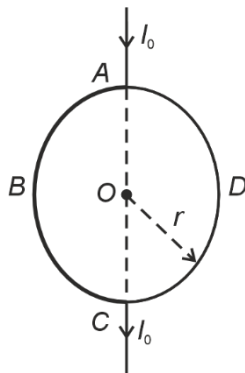

- (1) $\frac{\mu_0 I_0}{4r}$ (2) $\frac{\mu_0 I_0}{2r}$
 (3) $\frac{\mu_0 I_0}{2\pi r}$ (4) $\frac{\mu_0 I_0}{12r}$

Answer (4)

25. A particle of mass M moves along a horizontal x axis from $x = 0$ to $x = L$. The coefficient of kinetic friction varies as a function of x as $\mu_k(x) = \mu_0 - \alpha x$, where μ_0, α are constants of appropriate dimensions, so that $\mu_k(L) = 0$. The total work done by the frictional force during the motion is $n\mu_0 MgL$, where g is the acceleration due to gravity. The value of n is:

- (1) 1 (2) $\frac{1}{3}$
 (3) $\frac{1}{2}$ (4) 3

Answer (3)

26. In a solar system, the time-period of revolution of a planet tracing a circular orbit of radius R is proportional to:

- (1) $R^{3/2}$ (2) R^2
 (3) R^3 (4) $R^{1/2}$

Answer (1)

27. A solid sphere A of radius R and mass M is attached at a point to a smaller solid sphere B of radius $r < R$ and mass $m < M$. Assume that the line joining their centres lies along the horizontal. The moment of inertia of the system calculated about a vertical axis passing through the centre of A is I_A and that calculated about a vertical axis passing through the centre of B is I_B . The difference $I_A - I_B$ is:

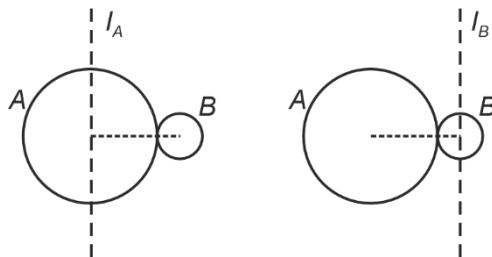

- (1) $(m - M)(R + r)^2$ (2) $(m - M)(R - r)^2$
 (3) 0 (4) $(M - m)(R + r)^2$

Answer (1)

31. A conducting loop of finite resistance lies on the $x - y$ plane. There is a constant magnetic field in the z direction. The area of the loop varies with time t , as $A = A_0(1 + \sin t)$ in appropriate units. The figure that correctly indicates the qualitative behaviour of the power P dissipated in the loop as a function of time is:

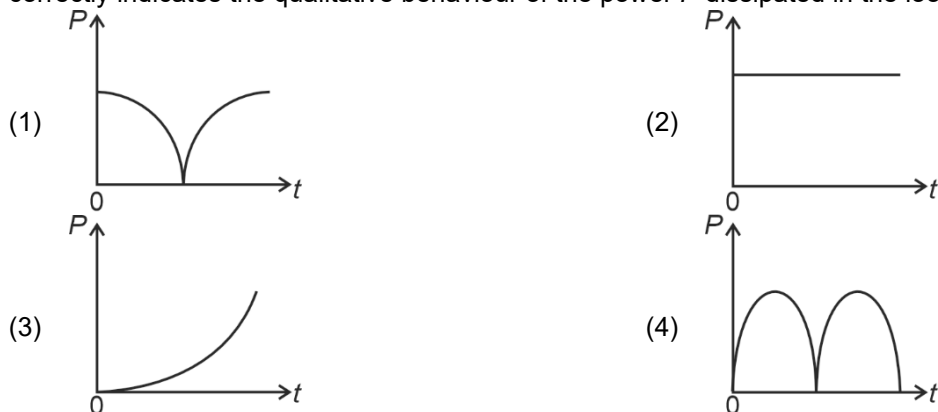

Answer (1)

32. Consider two circuits, (A) and (B), each having two resistors. One of them has a positive temperature coefficient of resistance, $+\alpha$, while the other one has a negative temperature coefficient of resistance, $-\alpha$, as shown in the figure. The current through these circuits are denoted by I_A and I_B . At initial temperature, the resistance of the two resistors is R_0 . As the temperature is increased, the correct option that describes the variation of current in these circuits is:

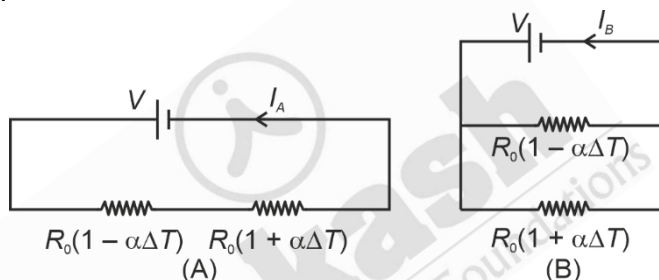

- (1) I_A decreases while I_B increases
 (2) I_A increases while I_B decreases
 (3) Both I_A and I_B remain constant
 (4) I_A remains constant while I_B increases

Answer (4)

33. Bob B of mass m at rest is hanging vertically from the ceiling via a massless string of length 10 m, as shown in the figure. Point mass A of mass m travelling horizontally with speed 10 ms^{-1} hits bob B elastically. The bob B rises h meter after the collision. Taking the acceleration due to gravity $g = 10 \text{ ms}^{-2}$ and neglecting the size of the bob, the value of h is:

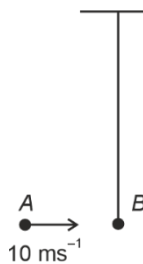

- (1) 7
 (2) 5
 (3) 2.5
 (4) 8

Answer (2)

34. A cylindrical cork of uniform density floats in a liquid of density ρ_1 . If the cork is depressed slightly and released, it oscillates harmonically with time period T . If the same cork floats in another liquid of density ρ_2 , then the similar oscillation has time period $2T$. The value of ρ_2 / ρ_1 is:

- (1) 2
 (2) 1/2
 (3) 1/4
 (4) 4

Answer (3)

35. The mean free path of molecules in an ideal gas A is half that of another ideal gas B . The diameter of the spherical molecules of gas A is twice the diameter of the molecules of B . If number densities of the gases A and B are n_A and n_B , respectively, the correct option is:

- (1) $n_A = 2n_B$ (2) $n_A = \frac{1}{4}n_B$
 (3) $n_A = \frac{1}{2}n_B$ (4) $n_A = n_B$

Answer (3)

36. Consider the following nuclear reaction

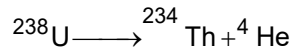

Take masses of ${}^{238}\text{U}$, ${}^{234}\text{Th}$ and ${}^4\text{He}$ as 238.050 u, 234.043 u and 4.003 u, respectively. The Q value for the reaction, in keV, is:

[Given: $1 \text{ u} = 931.5 \text{ MeV c}^{-2}$]

- (1) 3730 (2) 3736
 (3) 3740 (4) 3726

Answer (4)

37. Consider a long solenoid of length l and radius r . If n is the number of turns per unit length and μ_0 is the permeability of free space, the inductance of the solenoid is :

- (1) $\mu_0 n^2 r^2 l$ (2) $(\mu_0/2\pi)n^2 r^2 l$
 (3) $2\mu_0 \pi n^2 r^2 l$ (4) $\mu_0 \pi n^2 r^2 l$

Answer (4)

38. Which of the following measurements require 'index correction'?

- (1) Measurement of gravitational acceleration using simple pendulum
 (2) Measurement of focal length of lenses using optical bench
 (3) Measurement of speed of sound using resonance tube
 (4) Measurement of resistance of a wire using meter bridge

Answer (2)

39. The temperature of a metallic sphere of radius R is increased by a small amount ΔT . If the linear coefficient of thermal expansion of the metal is α , the approximate increase in the volume of the sphere is:

- (1) $3\pi R^3 \alpha \Delta T$ (2) $4\pi R^3 \alpha \Delta T$
 (3) $6\pi R^3 \alpha \Delta T$ (4) $2\pi R^3 \alpha \Delta T$

Answer (2)

40. A photon and an electron, each of 20 eV energy, move in free space. The ratio of linear momentum of electron

p_e to that of photon p_{ph} , $\frac{p_e}{p_{ph}}$ is:

[Take speed of light = $3 \times 10^8 \text{ ms}^{-1}$, charge of electron = $-1.6 \times 10^{-19} \text{ C}$ and mass of electron = $9 \times 10^{-31} \text{ kg}$]

- (1) $\frac{1}{250}$ (2) 225
 (3) 275 (4) $\frac{2}{450}$

Answer (2)

41. Consider that an electron is revolving in an excited state of Hydrogen atom with velocity $\sqrt{25.6} \times 10^5 \text{ ms}^{-1}$. The radius of the orbit is $x \times 10^{-9} \text{ m}$. The value of x is:

[Take the mass of electron to be $9 \times 10^{-31} \text{ kg}$, charge of electron = $-1.6 \times 10^{-19} \text{ C}$ and $\frac{1}{4\pi\epsilon_0} = 9 \times 10^9 \text{ Nm}^2\text{C}^{-2}$]

- (1) 3 (2) 2
 (3) 1 (4) 4

Answer (3)

42. Two identical inductors are connected in two different configurations P and Q , where a time varying current $I(t)$ is flowing, as shown in the figure. The induced emf between points a and b for configuration P is E_P and that for configuration Q is E_Q . The ratio E_P/E_Q is:
[Neglect the effect of mutual inductance.]

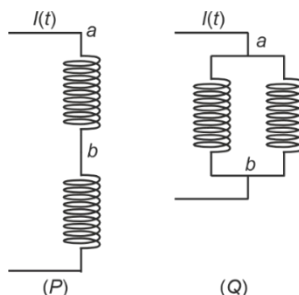

- (1) $\frac{1}{2}$ (2) 1
(3) 2 (4) $\frac{1}{4}$

Answer (3)

43. In an adiabatic expansion, the temperature of one mole of an ideal monatomic gas ($\gamma = 5/3$) decreases from 60 K to 50 K. The work done by the gas in the process is:

(Take the universal gas constant as $R = 8.3 \text{ J mol}^{-1} \text{ K}^{-1}$)

- (1) 83 J (2) 124.5 J
(3) 166 J (4) 41.5 J

Answer (2)

44. Water flows in a streamline motion through a horizontal pipe of circular cross-section as shown in the figure. The pressure difference of water between P and Q is 15 Nm^{-2} . The area of cross-section at P and Q are 40 cm^2 and 20 cm^2 , respectively. The rate of flow of water through the pipe, in cm^3s^{-1} , is:

[Take density of water = 1000 kg m^{-3}]

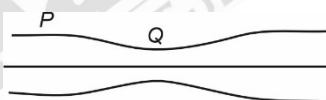

- (1) 200 (2) 300
(3) 400 (4) 100

Answer (3)

45. A thin horizontal disc is rotating about a vertical axis passing through its fixed centre O . Its angular momentum is L_A and L_B computed about points A and B , respectively, with $OB = 2 \times OA$. The value of $\frac{L_A}{L_B}$ is:

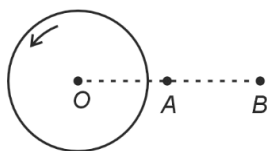

- (1) $\frac{1}{2}$ (2) 1
(3) 2 (4) $\frac{1}{4}$

Answer (2)

50. The compound that **CANNOT** be obtained from the aldol condensation reaction shown below, is

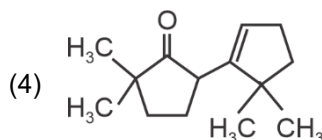
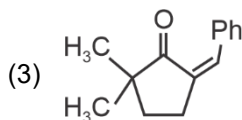
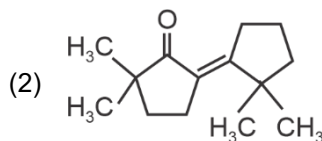
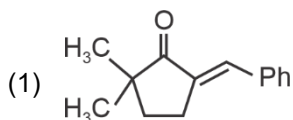
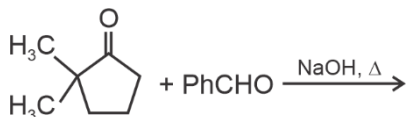

Answer (4)

51. For a salt **XY**, which is a strong electrolyte, the plot of Λ_m versus \sqrt{c} has a slope of $-90.0 \text{ S cm}^2 \text{ mol}^{-3/2} \text{ L}^{1/2}$ at 298 K. At 0.01 M concentration of **XY**, the value of Λ_m is $145.0 \text{ S cm}^2 \text{ mol}^{-1}$. The limiting molar conductivity of Y^- ion ($\lambda_{\text{Y}^-}^0$, in $\text{S cm}^2 \text{ mol}^{-1}$) at 298 K will be

(Given : $\lambda_{\text{X}^+}^0 = 74.0 \text{ S cm}^2 \text{ mol}^{-1}$)

(1) 100.0

(2) 90.0

(3) 76.0

(4) 80.0

Answer (4)

52. Given below are two statements: One is labelled as **Assertion A** and the other is labelled as **Reason R**.

Assertion A: The first ionization enthalpy of O is lower than that of N and F.

Reason R: The loss of an electron from O leads to stable half-filled p orbital.

In light of the above statements, choose the **most appropriate** answer from the options given below:

(1) Both **A** and **R** are correct and **R** is **NOT** the correct explanation of **A**

(2) **A** is correct but **R** is not correct.

(3) **A** is not correct but **R** is correct

(4) Both **A** and **R** are correct and **R** is the correct explanation of **A**

Answer (4)

53. According to crystal field theory, the correct order of ligands with respect to their decreasing order of field strength is

(1) $\text{CO} > \text{H}_2\text{O} > \text{NH}_3 > \text{Cl}^-$

(2) $\text{Cl}^- > \text{H}_2\text{O} > \text{NH}_3 > \text{CO}$

(3) $\text{Cl}^- > \text{NH}_3 > \text{H}_2\text{O} > \text{CO}$

(4) $\text{CO} > \text{NH}_3 > \text{H}_2\text{O} > \text{Cl}^-$

Answer (4)

54. Given below are two statements:

Statement-I : $[\text{Fe}(\text{ox})_3]^{3-}$ is chiral.

Statement-II : *trans* - $[\text{Cr}(\text{H}_2\text{O})_2(\text{ox})_2]^-$ is chiral.

(Given : $\text{oxH}_2 = \text{HOOC} - \text{COOH}$)

In light of the above statements, choose the **most appropriate** answer from the options given below:

- (1) Both **Statement-I** and **Statement-II** are incorrect
- (2) **Statement-I** is correct but **Statement-II** is incorrect
- (3) **Statement-I** is incorrect but **Statement-II** is correct
- (4) Both **Statement-I** and **Statement-II** are correct

Answer (2)

55. For the following reaction sequence, choose the correct option

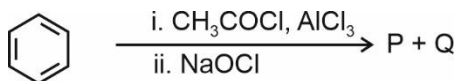

- (1) **P** and **Q** are aromatic compounds
- (2) If **P** gives a carboxylic acid on acidification, **Q** gives a poisonous gas on exposure to air and light
- (3) Both **P** and **Q** are carbonyl compounds
- (4) If **P** is the sodium salt of a carboxylic acid, **Q** is a primary alcohol

Answer (2)

56. For an elementary chemical reaction, the Arrhenius plot is given below.

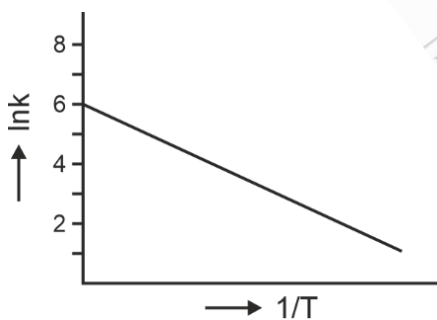

If the energy of activation is 6.64 kJ mol^{-1} and $R = 8.3 \text{ J K}^{-1} \text{ mol}^{-1}$, the temperature at which the rate constant becomes $e^2 \text{ min}^{-1}$, is

- | | |
|-----------|-----------|
| (1) 150 K | (2) 200 K |
| (3) 250 K | (4) 125 K |

Answer (2)

57. Arrange the following compounds in the increasing order of polarity
- $\text{CH}_3\text{CH}_2\text{OCH}_2\text{CH}_3$
 - $\text{CH}_3\text{CH}_2\text{OH}$
 - CH_3COCH_3
 - CH_3COOH

Choose the correct answer from the options given below.

- $\text{C} < \text{A} < \text{D} < \text{B}$
- $\text{C} < \text{A} < \text{B} < \text{D}$
- $\text{A} < \text{C} < \text{B} < \text{D}$
- $\text{A} < \text{B} < \text{C} < \text{D}$

Answer (3)

58. A protein undergoes reversible thermal denaturation from its initial state **N** to denatured state **D** according to $\text{N} \rightleftharpoons \text{D}$. At 60°C , the concentrations of both **N** and **D** are equal at equilibrium, and the standard enthalpy change of denaturation is 666 kJ mol^{-1} . The standard entropy change (ΔS° in $\text{kJ K}^{-1} \text{ mol}^{-1}$) of the protein upon denaturation at 60°C is closest to

- 2000.0
- 333.0
- 11.1
- 2.0

Answer (4)

59. Consider the following statements about the solutions formed by mixing two liquids.
- An ideal solution thus formed obeys Raoult's law throughout the composition range.
 - Mixture of chloroform and acetone shows negative deviation from Raoult's law.
 - Mixture of aniline and phenol shows positive deviation from Raoult's law.

- B and C only
- A only
- A and C only
- A and B only

Answer (4)

60. Given below are two statements :

Statement-I : Heating NaCl with concentrated H_2SO_4 and MnO_2 results in oxidation of Mn .

Statement-II : Heating NaI with concentrated H_2SO_4 and MnO_2 results in reduction of Mn .

In light of the above statements, choose the **most appropriate** answer from the options given below.

- Both **Statement-I** and **Statement-II** are incorrect
- Statement-I** is correct but **Statement-II** is incorrect
- Statement-I** is incorrect but **Statement-II** is correct
- Both **Statement-I** and **Statement-II** are correct

Answer (3)

61. Given below are two statements :

Statement I : *trans*-But-2-ene upon treatment with Br₂ in CCl₄ gives the following product.

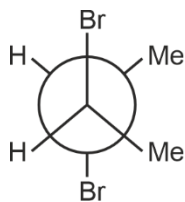

Statement II : *cis*-But-2-ene upon treatment with alkaline KMnO₄ gives the following product.

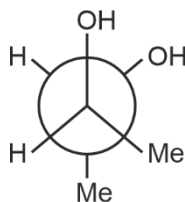

In the light of the above statements, choose the **most appropriate** answer from the options given below.

- (1) Both **Statement I** and **Statement II** are incorrect
- (2) **Statement I** is correct but **Statement II** is incorrect
- (3) **Statement I** is incorrect but **Statement II** is correct
- (4) Both **Statement I** and **Statement II** are correct

Answer (3)

62. The highest occupied molecular orbital for Ne₂ is

- (1) σ_{2p}
- (2) π_{2p}^*
- (3) σ_{2p}^*
- (4) π_{2p}

Answer (3)

63. The following carbocation is stabilized by the interaction of the empty *p* orbital with

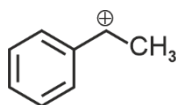

- (1) empty σ and empty π^* orbitals
- (2) empty σ^* and filled π orbitals
- (3) empty σ^* and empty π^* orbitals
- (4) filled σ and filled π orbitals

Answer (4)

64. The green paramagnetic species formed by heating KMnO₄ at 513 K is

- (1) Mn₃O₄
- (2) MnO
- (3) KO₂
- (4) K₂MnO₄

Answer (4)

65. The correct statement is
- (1) Beryllium has three valence orbitals.
 - (2) Magnesium has a maximum covalency of four.
 - (3) Aluminium has five valence orbitals.
 - (4) Boron has a maximum covalency of four.

Answer (4)

66. The correct statement about peptides and proteins is
- (1) Only the proteins having a quaternary structure are biologically active
 - (2) In β -pleated sheet structures, peptide chains are held together by intermolecular hydrogen bonds
 - (3) In α -helices, the polypeptide chain is twisted into a left-handed screw (helix) through intramolecular hydrogen bonds
 - (4) Tertiary structure of proteins has two or more polypeptide subunits

Answer (2)

67. $2A \xrightarrow{k} B$ is a zero-order reaction, where $k = 1.0 \text{ mol L}^{-1} \text{ min}^{-1}$. If the initial concentration of A is 2 M, then the time taken to complete 75% of the reaction will be
- (1) 0.75 min
 - (2) 1.0 min
 - (3) 2.0 min
 - (4) 1.5 min

Answer (1)

68. Given below are two statements: One is labelled as **Assertion A** and the other is labelled as **Reason R**.

Assertion A: Generally, 3d transition metals have high melting points.

Reason R: Involvement of 3d-electrons in addition to 4s-electrons in the interatomic metallic bonding.

In light of the above statements, choose the **most appropriate** answer from the options given below:

- (1) Both **A** and **R** are correct and **R** is **NOT** the correct explanation of **A**
- (2) **A** is correct but **R** is not correct.
- (3) **A** is not correct but **R** is correct
- (4) Both **A** and **R** are correct and **R** is the correct explanation of **A**

Answer (4)

69. Consider the following schematic plots of orbital wavefunction (ψ_r) against distance (r) from the nucleus.

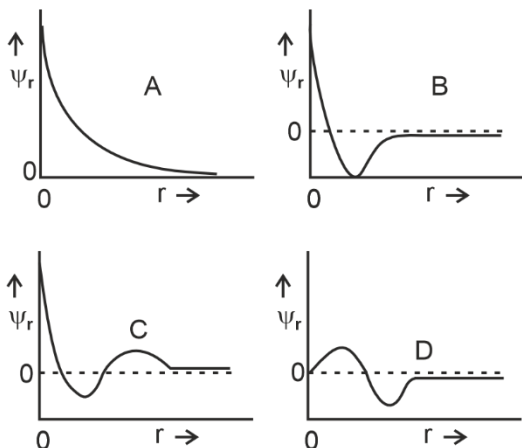

The figure representing two radial nodes in the orbital is

- (1) B (2) C
(3) D (4) A

Answer (2)

70. Identify the reactions which give aniline as the major product.

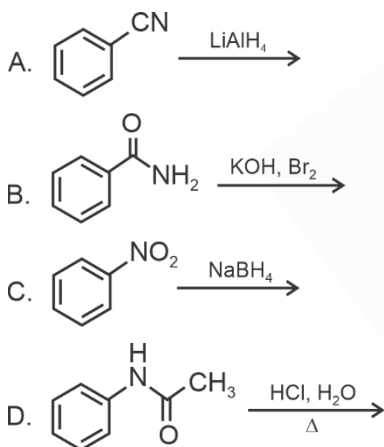

Choose the correct answer from the options given below.

- (1) B and D only (2) A and C only
(3) C and D only (4) A and B only

Answer (1)

71. Among the species given below, the spin-only magnetic moment is highest for
(Given: Atomic number of Ti = 22, Mn = 25, Fe = 26 and Co = 27)

- (1) $[\text{Fe}(\text{CN})_6]^{3-}$ (2) $[\text{Co}(\text{NH}_3)_6]^{3+}$
(3) $[\text{Ti}(\text{H}_2\text{O})_6]^{3+}$ (4) $[\text{Mn}(\text{CN})_6]^{3-}$

Answer (4)

72. The complex which has *facial* and *meridional* isomers is

(Given : py = pyridine and en = H₂N – CH₂ – CH₂ – NH₂)

- (1) [Cr(H₂O)₆]³⁺ (2) [Co(NH₃)₄(H₂O)₂]³⁺
(3) [Ni(en)₂(H₂O)₂]²⁺ (4) [Cr(py)₃(Cl)₃]

Answer (4)

73. A 1 : 3 electrolyte in an aqueous solution is

- (1) [CoCl(NH₃)₅]Cl₂ (2) [Co(NH₃)₆]Cl₃
(3) [Co(NH₃)₃(NO₂)₃] (4) [CoCl₂(NH₃)₄]Cl

Answer (2)

74. Consider the reversible processes for 1.0 mol of an ideal gas as shown in the figure.

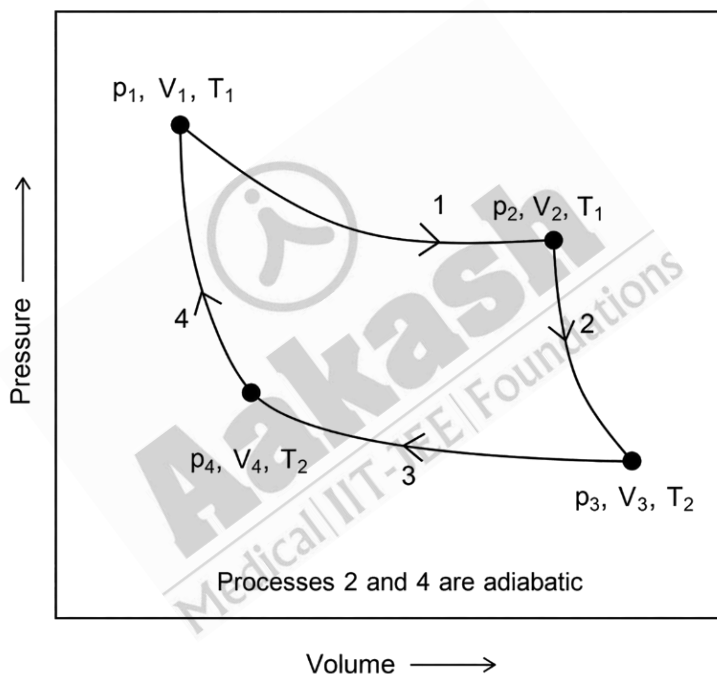

w_1, w_2, w_3 and w_4 represent work done (in calories) in the processes 1, 2, 3 and 4, respectively; ΔU_2 and ΔU_4 are changes in the internal energy for the processes 2 and 4, respectively.

[use $R = 2 \text{ cal K}^{-1} \text{ mol}^{-1}$]

The correct option is

- (1) $w_2 + w_4 = \Delta U_2 - \Delta U_4$ (2) $w_1 + w_2 = 2T_1 \ln \frac{V_2}{V_1}$
(3) $w_1 + w_2 + w_3 + w_4 = 0$ (4) $w_1 + w_3 = -2T_1 \ln \frac{V_2}{V_1} - 2T_2 \ln \frac{V_4}{V_3}$

Answer (4)

75. In an acidic medium, 10 mL of 0.25 M oxalic acid is titrated with KMnO_4 solution. If the volume of KMnO_4 solution required to reach end point is 10 mL, the strength of the KMnO_4 solution is
- (1) 0.20 M (2) 0.25 M
(3) 0.15 M (4) 0.10 M

Answer (4)

76. The lanthanide ion having four unpaired electrons is
(Given : Atomic numbers of Ce = 58, Nd = 60, Tb = 65 and Ho = 67)
- (1) Ce^{3+} (2) Tb^{3+}
(3) Ho^{3+} (4) Nd^{3+}

Answer (3)

77. The correct decreasing order of oxidation state of the underlined atom in each molecule is
- (1) $\underline{\text{N}}_2\text{O}_5 > \underline{\text{Al}}_2\text{O}_3 > \underline{\text{H}}_2\text{S}$ (2) $\underline{\text{Pb}}\text{O}_2 > \underline{\text{N}}_2\text{O}_3 > \underline{\text{S}}\text{O}_3$
(3) $\underline{\text{P}}_4\text{O}_6 > \underline{\text{Cl}}_2\text{O}_7 > \underline{\text{Al}}\text{H}_3$ (4) $\underline{\text{P}}_4\text{O}_{10} > \underline{\text{S}}\text{O}_3 > \underline{\text{H}}_2\text{O}$

Answer (1)

78. The formula of tetraammineaquachloridocobalt(III) chloride is
- (1) $[\text{Co}(\text{NH}_3)_4]\text{Cl}_3 \times \text{H}_2\text{O}$ (2) $[\text{Co}(\text{NH}_3)_4(\text{H}_2\text{O})\text{Cl}]\text{Cl}$
(3) $[\text{Co}(\text{NH}_3)_4(\text{H}_2\text{O})\text{Cl}]\text{Cl}_2$ (4) $[\text{Co}(\text{NH}_3)_4\text{Cl}_2] \times \text{H}_2\text{O}$

Answer (3)

79. Consider the following reaction, and choose the correct option.

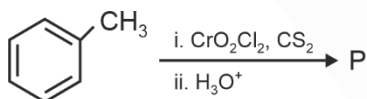

- (1) Compound **P** can be prepared by treating benzene with anhydrous AlCl_3 and CH_3COCl
(2) On treatment with bromine water, compound **P** gives a white precipitate
(3) Compound **P** is obtained by the hydrogenation of benzoyl chloride with Pd on BaSO_4
(4) On treating compound **P** with saturated NaHCO_3 solution, brisk effervescence is observed

Answer (3)

80. **Assertion A:** For an ideal solution formed by mixing liquids **P** and **Q**, $\Delta_{\text{mix}} H = 0$ and $\Delta_{\text{mix}} V = 0$

Reason R: No interactions occur between **P** and **Q**

In the light of the above statements, choose the **most appropriate** answer from the options given below.

- (1) Both **A** and **R** are correct but **R** is **NOT** the correct explanation of **A**
(2) **A** is correct but **R** is not correct
(3) **A** is not correct but **R** is correct
(4) Both **A** and **R** are correct and **R** is the correct explanation of **A**

Answer (2)

86. The correct order of solubility of the given salts in water at 298 K is

Salt	K_{sp} at 298 K
AgBr	5.0×10^{-13}
Zn(OH) ₂	1.0×10^{-15}
Hg ₂ Cl ₂	1.3×10^{-18}

- (1) AgBr > Zn(OH)₂ > Hg₂Cl₂ (2) Hg₂Cl₂ > AgBr > Zn(OH)₂
 (3) Zn(OH)₂ > AgBr > Hg₂Cl₂ (4) Hg₂Cl₂ > Zn(OH)₂ > AgBr

Answer (3)

87. Consider the following reaction sequences and choose the correct option.

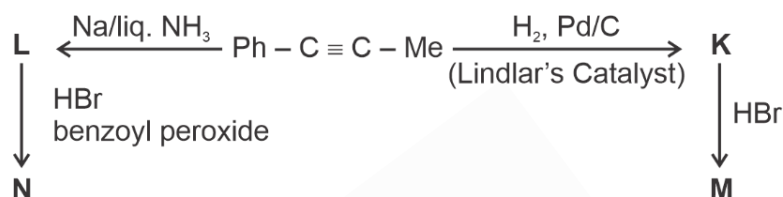

- (1) K and L are enantiomers
 (2) M and N are geometrical isomers
 (3) M and N are stereoisomers
 (4) K and L are geometrical isomers

Answer (4)

88. The amount of carbon dioxide evolved upon complete combustion of 116 g of n-butane is

(Given: atomic mass in amu H = 1, C = 12 and O = 16)

- (1) 322 g (2) 176 g
 (3) 362 g (4) 352 g

Answer (4)

89. The numbers 17.0145 and 21.0235 were rounded to three figures after the decimal point. The resulting numbers, respectively, are

- (1) 17.015 and 21.023 (2) 17.014 and 21.024
 (3) 17.015 and 21.024 (4) 17.014 and 21.023

Answer (2)

90. In potash alum, the ratio of K⁺ and SO₄²⁻ ions is

- (1) 2 : 1 (2) 2 : 3
 (3) 3 : 2 (4) 1 : 2

Answer (4)

BIOLOGY

91. The number of vertebrae in a human is _____.
- (1) 12 (2) 26
(3) 206 (4) 7

Answer (2)

92. Which one of the following statements is **incorrect**?
- (1) α -cells of pancreas secrete insulin
(2) Glucagon stimulates glycogenolysis
(3) β -cells of pancreas secrete insulin
(4) α -cells of pancreas secrete glucagon

Answer (1)

93. Given below are two statements:

Statement I : The class name Reptilia refers to creeping or crawling mode of locomotion.

Statement II : All organisms belonging to Reptilia have three chambered heart.

In the light of the above statements, choose the **most appropriate** answer from the options given below:

- (1) Both **Statement I** and **Statement II** are incorrect
(2) **Statement I** is correct but **Statement II** is incorrect
(3) **Statement I** is incorrect but **Statement II** is correct
(4) Both **Statement I** and **Statement II** are correct

Answer (2)

94. Which of the following statements related to pituitary gland are **correct**?
- (a) It is divided anatomically into adenohypophysis and neurohypophysis
(b) It secretes follicle stimulating hormone
(c) It secretes melanocyte stimulating hormone
(d) It does not secrete prolactin

Choose the **correct** answer from the options given below :

- (1) (a), (b) and (c) only (2) (c) and (d) only
(3) (b) and (c) only (4) (a) and (b) only

Answer (1)

95. Match **List-I** with **List-II**.

	List-I		List-II
A.	Starch	I.	Fights infection
B.	Antibody	II.	Energy storage
C.	Concanavalin A	III.	Glucose transport
D.	Glut-4	IV.	Lectin

Choose the **correct** answer from the options given below :

- (1) A-II, B-I, C-IV, D-III
- (2) A-II, B-I, C-III, D-IV
- (3) A-I, B-II, C-III, D-IV
- (4) A-I, B-II, C-IV, D-III

Answer (1)

96. In water, frogs respire using _____.

- (1) buccal cavity
- (2) lungs
- (3) trachea
- (4) skin

Answer (4)

97. Match **List-I** with **List-II**.

	List-I		List-II
A.	Cristae	I.	Flat membrane sacs in stroma of chloroplast
B.	Cisternae	II.	Infoldings in mitochondria
C.	Thylakoids	III.	Cell membrane
D.	Phospholipid	IV.	Disc shaped sacs in the Golgi apparatus

Choose the **correct** answer from the options given below:

- (1) A-II, B-IV, C-I, D-III
- (2) A-II, B-IV, C-III, D-I
- (3) A-IV, B-III, C-I, D-II
- (4) A-III, B-IV, C-I, D-II

Answer (1)

98. Phyllotaxy is the pattern of arrangement of _____.

- (1) flowers
- (2) fruits
- (3) sepals
- (4) leaves

Answer (4)

99. Match **List-I** with **List-II**.

	List-I		List-II
A.	Spherical	I.	Vibrio
B.	Rod	II.	Cocci
C.	Comma	III.	Spirilla
D.	Spirillum	IV.	Bacilli

Choose the **correct** answer from the options given below :

- (1) A-III, B-II, C-I, D-IV
- (2) A-II, B-I, C-IV, D-III
- (3) A-II, B-IV, C-I, D-III
- (4) A-I, B-III, C-II, D-IV

Answer (3)

100. Arrange the following elements in descending order of their contribution to percentage weight of the human body.

- (a) Oxygen
- (b) Carbon
- (c) Hydrogen
- (d) Nitrogen

Choose the **correct** answer from the options given below :

- | | |
|------------------------|------------------------|
| (1) (c), (a), (b), (d) | (2) (b), (c), (d), (a) |
| (3) (b), (a), (c), (d) | (4) (a), (b), (c), (d) |

Answer (4)

101. Length of the stem at time 0 is 20 cm. The arithmetic growth rate is 30 cm per day. What is the length of the stem at the end of the 7th day?

- (1) 170 cm
- (2) 230 cm
- (3) 460 cm
- (4) 50 cm

Answer (2)

102. Given below are two statements:

Statement I: In gymnosperms, the male and female gametophytes remain within the sporangia.

Statement II: In gymnosperms, seeds are not covered.

In the light of the above statements, choose the **most appropriate** answer from the options given below:

- (1) Both **Statement I** and **Statement II** are incorrect
- (2) **Statement I** is correct but **Statement II** is incorrect
- (3) **Statement I** is incorrect but **Statement II** is correct
- (4) Both **Statement I** and **Statement II** are correct

Answer (4)

103. Smooth endoplasmic reticulum _____ .

- (1) is the major site for the synthesis of lipids
- (2) is actively involved in protein synthesis
- (3) is a site for the synthesis of carbohydrates
- (4) has ribosomes attached to its surface

Answer (1)

104. Which of the following is **not** a characteristic of chordates?

- (1) Central nervous system is dorsal
- (2) Absence of gills
- (3) Presence of post anal part (tail)
- (4) Presence of notochord

Answer (2)

105. How many molecules of pyruvic acid are produced at the end of glycolysis from 206 molecules of glucose?

- (1) 309
- (2) 103
- (3) 412
- (4) 206

Answer (3)

106. The correct sequence of adult cell cycle phases is _____.

- (1) G1-M-G2-S
- (2) G1-S-G2-M
- (3) S-M-G2-G1
- (4) G1-G2-S-M

Answer (2)

107. Which of the following represents the correct sequence of arrangement of bones in the lower limb of humans?

- (1) Patella-femur-tibia-tarsal
- (2) Femur-patella-tibia-tarsal
- (3) Femur-tarsal-patella-tibia
- (4) Femur-tibia-patella-tarsal

Answer (2)

108. Cell theory was formulated by _____.

- (1) Robert Brown
- (2) Singer and Nicolson
- (3) Antonie Von Leeuwenhoek
- (4) Schleiden and Schwann

Answer (4)

109. Given below are two statements :

Statement I : Chromosomes are fully condensed at the end of prophase I.

Statement II : Meiosis I resembles mitosis.

In the light of the above statements, choose the **most appropriate** answer from the options given below :

- (1) Both **Statement I** and **Statement II** are false
- (2) **Statement I** is correct, but **Statement II** is false
- (3) **Statement I** is incorrect, but **Statement II** is true
- (4) Both **Statement I** and **Statement II** are true

Answer (2)

110. Which of the following statements regarding photorespiration are correct?

- (a) Do not occur in C₃ plants
- (b) CO₂ is consumed and O₂ is generated
- (c) Phosphoglycolate is formed
- (d) No synthesis of ATP and NADPH

Choose the **correct** answer from the options given below:

- (1) (c) and (d) only
- (2) (b) and (d) only
- (3) (a) and (b) only
- (4) (a) and (d) only

Answer (1)

111. Which of the following are characteristics of prokaryotic cells?

- (a) Ribosomes are made of 50S and 30S subunits
- (b) They can have plasmids
- (c) They contain mesosome
- (d) They have peroxisomes

Choose the **correct** answer from the options given below :

- (1) (a) and (c) only
- (2) (a), (c) and (d) only
- (3) (a), (b) and (c) only
- (4) (b) and (c) only

Answer (3)

112. The number of action potentials generated by sino-atrial node (SAN) in a healthy human is _____ per minute.

- (1) 70 – 75
- (2) 100 – 110
- (3) 120 - 140
- (4) 28 - 30

Answer (1)

113. Endomembrane system includes _____.

- (1) endoplasmic reticulum, chloroplast, peroxisomes and vacuole
- (2) mitochondria, chloroplast, peroxisomes and vacuole
- (3) Golgi complex, chloroplast, peroxisomes and vacuole
- (4) endoplasmic reticulum, Golgi complex, lysosomes and vacuole

Answer (4)

114. Match **List-I** with **List-II**.

	List-I		List-II
A.	Family	I.	Sapindales
B.	Genus	II.	Dicotyledonae
C.	Class	III.	Anacardiaceae
D.	Phylum	IV.	Angiospermae
E.	Order	V.	<i>Mangifera</i>

Choose the **correct** answer from the options given below :

- (1) A-II, B-I, C-III, D-IV, E-V
- (2) A-II, B-III, C-V, D-I, E-IV
- (3) A-III, B-V, C-II, D-IV, E-I
- (4) A-I, B-V, C-II, D-IV, E-III

Answer (3*) (Conceptual errata)

115. Which of the following plant growth regulators promotes internode elongation prior to flowering in cabbage?

- (1) Gibberellin
- (2) Indole butyric acid
- (3) Ethephon
- (4) Abscisic acid

Answer (1)

116. The plastid that stores xanthophyll is known as _____.

- (1) chromoplast
- (2) aleuroplast
- (3) amyloplast
- (4) chloroplast

Answer (1)

117. Photorespiration reaction catalyzed by RuBisCo is shown below:



Identify "X" from the given options:

- (1) 2-Phosphoglycolate
- (2) Oxaloacetate
- (3) Malate
- (4) Phosphoenolpyruvate

Answer (1)

118. Match **List-I** with **List-II**.

	List-I		List-II
A.	Marginal placentation	I.	<i>Argemone</i>
B.	Axile placentation	II.	Tomato
C.	Parietal placentation	III.	<i>Primrose</i>
D.	Free central placentation	IV.	Pea

Choose the **correct** answer from the options given below :

- (1) A-IV, B-II, C-III, D-I
- (2) A-IV, B-III, C-I, D-II
- (3) A-IV, B-II, C-I, D-III
- (4) A-II, B-IV, C-I, D-III

Answer (3)

119. Which of the following are characteristic features of Solanaceae family?

- (a) Flowers are bisexual and actinomorphic
- (b) Calyx have five sepals and are united
- (c) Androecium have five stamens and are epipetalous
- (d) Ovary is inferior

Choose the **correct** answer from the options given below :

- (1) (d) only
- (2) (a) and (b) only
- (3) (b), (c) and (d) only
- (4) (a), (b) and (c) only

Answer (4)

120. Which pigment has absorption peak at 700 nm in the photosynthetic reaction centre PS I (P700)?

- (1) Chlorophyll a
- (2) Xanthophylls
- (3) Carotenoids
- (4) Chlorophyll b

Answer (1)

121. Mitochondrial inner membrane encloses _____.

- (1) cytosol
- (2) mucus
- (3) aqueous humor
- (4) matrix

Answer (4)

122. Which of the following statements is **incorrect**?

- (1) Blood clot consists of fibrins
- (2) Fibrin is produced from fibrinogen
- (3) Fibrinogen is produced from fibrin
- (4) Blood coagulates in response to an injury

Answer (3)

123. Symbiotic association between fungi and algae are called _____.

- (1) sponges
- (2) mycorrhiza
- (3) chrysophytes
- (4) lichens

Answer (4)

124. Which of the following is **not** a part of human central neural system?

- (1) Dura mater
- (2) Pia mater
- (3) Pericardium
- (4) Arachnoid

Answer (3)

125. Which of the following plant growth regulators is used as herbicide?

- (1) Kinetin
- (2) Abscisic acid
- (3) Gibberellin
- (4) 2, 4-D

Answer (4)

126. How many turns of Calvin cycle are required for the formation of three molecules of glucose?

- (1) 3
- (2) 1
- (3) 18
- (4) 6

Answer (3)

127. Arrange the following taxonomic categories in ascending order.

- (a) Genus
- (b) Class
- (c) Order
- (d) Phylum
- (e) Family
- (f) Kingdom
- (g) Species

Choose the **correct** answer from the options given below :

- (1) (a), (c), (d), (g), (f), (b), (e)
- (2) (g), (c), (d), (b), (e), (a), (f)
- (3) (f), (c), (b), (g), (d), (e), (a)
- (4) (g), (a), (e), (c), (b), (d), (f)

Answer (4)

128. In frogs, the number of pairs of cranial nerves arising from the brain are _____.

- (1) 9
- (2) 10
- (3) 12
- (4) 6

Answer (2)

129. Select the correct sequence of experiments that led to a gradual understanding of photosynthesis in green plants.

- (1) Role of air → release of oxygen → production of glucose → absorption spectra of chlorophyll a and b
- (2) Release of oxygen → production of glucose → absorption spectra of chlorophyll a and b → role of air
- (3) Production of glucose → role of air → release of oxygen → absorption spectra of chlorophyll a and b
- (4) Absorption spectra of chlorophyll a and b → production of glucose → release of oxygen → role of air

Answer (1)

130. Sphenopsida class belongs to _____.
- (1) angiosperms (2) gymnosperms
(3) pteridophytes (4) bryophytes

Answer (3)

131. Match **List-I** with **List-II**.

	List-I		List-II
A.	Fusion of protoplasts between gametes	I.	Meiosis
B.	Fusion of two nuclei	II.	Plasmogamy
C.	Generation of haploid spores	III.	Karyogamy

Choose the **correct** answer from the options given below :

- (1) A-II, B-I, C-III (2) A-III, B-II, C-I
(3) A-I, B-III, C-II (4) A-II, B-III, C-I

Answer (4)

132. Which of the following is **not** a prokaryote?

- (1) Blue green algae (2) Mycoplasma
(3) Fungi (4) Bacteria

Answer (3)

133. Given below are two statements :

Statement I : When any plane passing through the central axis of the body divides the organism into two identical halves, it is called radial symmetry.

Statement II : In phylum Echinodermata, both adults and larvae are radially symmetrical.

In the light of the above statements, choose the **most appropriate** answer from the options given below :

- (1) Both **Statement I** and **Statement II** are incorrect
(2) **Statement I** is correct but **Statement II** is incorrect
(3) **Statement I** is incorrect but **Statement II** is correct
(4) Both **Statement I** and **Statement II** are correct

Answer (2)

134. Genus represents _____.

- (1) a population of plants and animals (2) a group of closely related species
(3) a group of closely related families (4) an individual plant or animal

Answer (2)

135. Mad cow disease is caused by _____.

- (1) viroids (2) *Aspergillus sp.*
(3) *Mycoplasma sp.* (4) prions

Answer (4)

136. The opening between the right atrium and the right ventricle is guarded by _____.

- (1) tricuspid valve (2) semilunar valve
 (3) sino-atrial node (4) bicuspid valve

Answer (1)

137. The inactive form of Bt toxin is converted to the active form in the insect gut _____

- (1) due to acidic pH (2) by proteases
 (3) by nucleases (4) due to alkaline pH

Answer (4)

138. Match **List-I** with **List-II**.

	List-I		List-II
A.	Transformation	I.	Restriction enzyme
B.	Cloning site	II.	Transfer DNA to host bacteria
C.	Selection	III.	Replication
D.	Ori	IV.	Antibiotic

Choose the **correct** answer from the options given below:

- (1) A-I, B-II, C-IV, D-III (2) A-III, B-IV, C-II, D-I
 (3) A-IV, B-I, C-III, D-II (4) A-II, B-I, C-IV, D-III

Answer (4)

139. How many theca are present in each lobe of a typical bilobed angiosperm anther?

- (1) 6 (2) 8
 (3) 12 (4) 2

Answer (4)

140. Which of the following hormone is **not** secreted by human placenta?

- (1) Estrogen
 (2) Progesterone
 (3) LH
 (4) hCG

Answer (3)

141. Sperm motility is due to _____.

- (1) ciliary movement
 (2) amoeboid movement
 (3) muscular movement
 (4) flagellar movement

Answer (4)

142. Given below are two statements : one is labelled as **Assertion A** and the other is labelled as **Reason R**.
Assertion A : In an experiment, Mendel observed that the F₁ progeny plants are all tall and none are dwarf.
Reason R : Stem height is a contrasting trait, with tall being dominant and dwarf being recessive.

In the light of the above statements, choose the **most appropriate** answer from the options given below :

- (1) Both **A** and **R** are correct but **R** is not the correct explanation of **A**
- (2) **A** is correct but **R** is not correct
- (3) **A** is not correct but **R** is correct
- (4) Both **A** and **R** are correct and **R** is the correct explanation of **A**

Answer (4)

143. During PCR, primers bind to the DNA strands in the _____ step.
- (1) extension
 - (2) annealing
 - (3) ligation
 - (4) denaturation

Answer (2)

144. Which of the following plant produces non-albuminous seeds?
- (1) Maize
 - (2) Barley
 - (3) Pea
 - (4) Wheat

Answer (3)

145. For a person with blood group 'O', which of the following is **not** a possible combination of parents' blood group genotypes?
- (1) Father : $I^A i$ and Mother : $I^A i$
 - (2) Father : $I^B i$ and Mother : $I^B i$
 - (3) Father : $I^A I^B$ and Mother : $I^A i$
 - (4) Father : $I^A i$ and Mother : $I^B i$

Answer (3)

146. Which of the following is used as a clot buster?
- (1) Penicillin
 - (2) Cyclosporin A
 - (3) Statins
 - (4) Streptokinase

Answer (4)

147. Arrange the following in descending order of number of species in the Amazonian rain forest.
- (a) Plants
 - (b) Birds
 - (c) Fishes
 - (d) Invertebrates
 - (e) Mammals

Choose the **correct** answer from the options given below :

- (1) (d) > (a) > (c) > (b) > (e)
- (2) (e) > (b) > (a) > (c) > (d)
- (3) (b) > (a) > (d) > (c) > (e)
- (4) (c) > (b) > (d) > (e) > (a)

Answer (1)

148. Given below are two statements :

Statement I : Plasmids are autonomously replicating DNA.

Statement II : Plasmids are extrachromosomal DNA.

In the light of the above statements, choose the **most appropriate** answer from the options given below :

- (1) Both **Statement I** and **Statement II** are incorrect
- (2) **Statement I** is correct but **Statement II** is incorrect
- (3) **Statement I** is incorrect but **Statement II** is correct
- (4) Both **Statement I** and **Statement II** are correct

Answer (4)

149. Given below are two statements : one is labelled as **Assertion A** and the other is labelled as **Reason R**.

Assertion A : Forelimbs of human and bats are homologous.

Reason R : Forelimbs of humans and bats have similar anatomical structure.

In the light of the above statements, choose the **most appropriate** answer from the options given below.

- (1) Both **A** and **R** are true, but **R** is not the correct explanation of **A**
- (2) **A** is true but **R** is false
- (3) **A** is false but **R** is true
- (4) Both **A** and **R** are correct and **R** is the correct explanation of **A**

Answer (4)

150. Which of the following statements about the reabsorption process in Henle's loop are **correct**?

- (a) The descending limb of Henle's loop is permeable to water but almost impermeable to electrolytes.
- (b) Urine gets concentrated in Henle's loop.
- (c) Reabsorption of Na^+ and water takes place in Henle's loop.
- (d) Active or passive transport of electrolytes occurs in the ascending limb of Henle's loop.

Choose the **correct** answer from the options given below:

- (1) (b), (c) and (d) only
- (2) (a), (b) and (c) only
- (3) (a), (b) and (d) only
- (4) (a) and (b) only

Answer (*)

151. Which of the following are secondary lymphoid organs?

- | | |
|-----------------|-------------|
| (a) Bone marrow | (b) Tonsils |
| (c) Spleen | (d) Thymus |

Choose the **correct** answer from the options given below:

- (1) (b) and (c) only
- (2) (b) and (d) only
- (3) (a) and (d) only
- (4) (a) and (b) only

Answer (1)

152. Which of the following is the **correct** order of arrangement of vertebrate column from the head to toe?

- (1) Sacrum, lumbar vertebra, thoracic vertebra, cervical vertebra
- (2) Cervical vertebra, lumbar vertebra, thoracic vertebra, sacrum
- (3) Cervical vertebra, thoracic vertebra, lumbar vertebra, sacrum
- (4) Cervical vertebra, thoracic vertebra, sacrum, lumbar vertebra

Answer (3)

153. If the diploid chromosome number of typical angiosperm is 36, what would be the chromosome number in its endosperm?

- | | |
|--------|--------|
| (1) 36 | (2) 54 |
| (3) 72 | (4) 18 |

Answer (2)

154. Sponges exchange O₂ with CO₂ by _____.

- (1) moist cuticle
- (2) tracheal tubes
- (3) gills
- (4) simple diffusion over their entire body surfaces

Answer (4)

155. Which of the following disease is **not** sexually transmitted?

- | | |
|-------------------|----------------|
| (1) Tuberculosis | (2) Gonorrhoea |
| (3) Genital warts | (4) Syphilis |

Answer (1)

156. Which of the following in female gametophyte of an angiosperm helps in guiding the pollen tube for fertilizing the eggs?

- | | |
|-------------------|-------------------|
| (1) Synergids | (2) Central cells |
| (3) Polar nucleus | (4) Antipodals |

Answer (1)

157. Match **List-I** with **List-II**.

- | List-I | List-II |
|---------------------------|--|
| (A) Excess growth hormone | (I) Reabsorption of water and electrolytes in kidney |
| (B) Luteinizing hormone | (II) Contraction of uterus during child birth |
| (C) Vasopressin | (III) Acromegaly |
| (D) Oxytocin | (IV) Ovulation |

Choose the **correct** answer from the options given below:

- (1) A-III, B-IV, C-I, D-II
- (2) A-II, B-IV, C-I, D-III
- (3) A-IV, B-III, C-I, D-II
- (4) A-III, B-IV, C-II, D-I

Answer (1)

158. The covering of ovum at ovulation is _____.
- (1) zona radiata (2) zona pellucida
 (3) chorion (4) endometrium

Answer (2)

159. Match **List-I** with **List-II**.

	List-I		List-II
A.	Both species are harmed	I.	Predation
B.	One species is harmed and the other is benefited	II.	Mutualism
C.	Both species are benefited	III.	Competition
D.	One is benefited while the other has no effect	IV.	Commensalism

Choose the **correct** answer from the options given below:

- (1) A-I, B-II, C-III, D-IV (2) A-II, B-I, C-IV, D-III
 (3) A-III, B-I, C-II, D-IV (4) A-III, B-IV, C-II, D-I

Answer (3)

160. Which of the following structure is **not** a part of the male reproductive system?
- (1) Epididymis (2) Vasa efferentia
 (3) Infundibulum (4) Rete testis

Answer (3)

161. Which of the following are primary consumers in a food chain?
- (1) Predators (2) Herbivores
 (3) Carnivores (4) Parasites

Answer (2)

162. Given below are two statements : one is labelled as **Assertion A** and the other is labelled as **Reason R**.
Assertion A : Abingdon tortoise in Galapagos islands became extinct within a decade after goats were introduced.

Reason R : Goats were more efficient at browsing than Abingdon tortoise.

In the light of the above statements, choose the **most appropriate** answer from the options given below:

- (1) Both **A** and **R** are correct but **R** is not the correct explanation of **A**
 (2) **A** is correct but **R** is not correct
 (3) **A** is not correct but **R** is correct
 (4) Both **A** and **R** are correct and **R** is the correct explanation of **A**

Answer (4)

163. Which of the following statements about *lac*-operon is **correct**?
- (1) Lactose activates repressor to bind to the operator
 (2) Genes *i*, *z*, *y* and *a* share single common promoter
 (3) Galactose can act as an inducer of *lac* operon
 (4) Gene *i* is constitutively expressed

Answer (4)

164. Which of the following statements is **correct** about *Plasmodium*?

- (1) Reproduces sexually in RBCs
- (2) Gametocytes develop in mosquito gut
- (3) Fertilization takes place in mosquito gut
- (4) Reproduces sexually in liver cells

Answer (3)

165. A population of diploid organisms is at Hardy-Weinberg equilibrium. If the frequency of allele A is 0.1, the frequency of AA is _____.

- | | |
|----------|----------|
| (1) 0.02 | (2) 0.10 |
| (3) 0.99 | (4) 0.01 |

Answer (4)

166. Adaptive radiation in placental mammals and Australian Marsupials leading to similarity between distant species is an example of _____.

- | | |
|--------------------------|-------------------------|
| (1) convergent evolution | (2) founder effect |
| (3) genetic drift | (4) divergent evolution |

Answer (1)

167. Colostrum, secreted by mother during initial days of lactation, is abundant in _____.

- | | |
|---------|---------|
| (1) IgM | (2) IgA |
| (3) IgD | (4) IgG |

Answer (2)

168. Given below are two statements : one is labelled as **Assertion A** and the other is labelled as **Reason R**.

Assertion A : In recombinant DNA technology, lysozyme is used for disrupting bacterial cells while cellulase is for plant cells.

Reason R : Isolation of genetic material needs disruption of cells.

In the light of the above statements, choose the **most appropriate** answer from the options given below :

- (1) Both **A** and **R** are correct but **R** is not the correct explanation of **A**
- (2) **A** is correct but **R** is not correct
- (3) **A** is not correct but **R** is correct
- (4) Both **A** and **R** are correct and **R** is the correct explanation of **A**

Answer (4)

169. Given below are two statements:

Statement I : Ovulation is caused by LH surge leading to rupture of Graafian follicles.

Statement II: Graafian follicle remaining after ovulation transform into corpus luteum and secretes large amount of estrogen.

In the light of the above statements, choose the **most appropriate** answer from the options given below:

- (1) Both **Statement I** and **Statement II** are incorrect
- (2) **Statement I** is correct but **Statement II** is incorrect
- (3) **Statement I** is incorrect but **Statement II** is correct
- (4) Both **Statement I** and **Statement II** are correct

Answer (2)

170. Natural selection can lead to _____.
- (a) stabilisation (b) genetic drift
(c) directional change (d) disruption

Choose the **correct** answer from the options given below :

- (1) (a), (c) and (d) only
(2) (a), (b), (c) and (d)
(3) (a) and (c) only
(4) (a) only

Answer (1)

171. The method of directly of injecting a sperm into ovum in assisted reproductive technology is called :
- (1) Zygote intra fallopian transfer (ZIFT)
(2) Intra cytoplasmic sperm injection (ICSI)
(3) Embryo transfer (ET)
(4) Gamete intra fallopian transfer (GIFT)

Answer (2)

172. Which of the following is used as an effective sedative and painkiller for treating post-surgery patients?
- (1) Antibiotics
(2) Morphine
(3) Anti-retroviral drugs
(4) Interferon

Answer (2)

173. Given below are two statements :

Statement I : Down's syndrome is caused by the absence of one of the X-chromosomes.

Statement II : Turner's syndrome is caused by the presence of an additional copy of the chromosomes.

In the light of the above statements, choose the **correct** answer from the options given below :

- (1) Both **Statement I** and **Statement II** are incorrect
(2) **Statement I** is correct but **Statement II** is incorrect
(3) **Statement I** is incorrect but **Statement II** is correct
(4) Both **Statement I** and **Statement II** are correct

Answer (1)

174. Which of the following is **not** evidence for evolution?
- (1) Paleontological evidence from fossil records
(2) Embryological support for evolution as proposed by Ernst Heckel
(3) Divergent evolution of anatomical structures such as forelimbs
(4) Convergent evolution of traits like wings of birds and butterflies

Answer (2/4*)

175. Given below are two statements : one is labelled as **Assertion A** and the other is labelled as **Reason R**.

Assertion A : The logistic growth model of populations is considered more realistic than the exponential growth model.

Reason R : Resources are finite.

In the light of the above statements, choose the **most appropriate** answer from the options given below :

- (1) Both **A** and **R** are correct but **R** is not the correct explanation of **A**
- (2) **A** is correct but **R** is not correct
- (3) **A** is not correct but **R** is correct
- (4) Both **A** and **R** are correct and **R** is the correct explanation of **A**

Answer (4)

176. Given below are two statements :

Statement I : Modern *Homo sapiens* arose in Australia and moved across continents.

Statement II : *Homo sapiens* arose around 75000 to 10000 years ago.

In the light of the above statements, choose the **most appropriate** answer from the options given below :

- (1) Both **Statement I** and **Statement II** are incorrect
- (2) **Statement I** is correct but **Statement II** is incorrect
- (3) **Statement I** is incorrect but **Statement II** is correct
- (4) Both **Statement I** and **Statement II** are correct

Answer (3)

177. Consider a population of 10 million cells. Given the per-capita birth rate of 0.002 (per unit time) and the per-capita death rate of 0.002 (per unit time), the expected number of cells after 10 generations is _____.

- (1) 5 million
- (2) 10 million
- (3) 100 million
- (4) 1 million

Answer (2)

178. Which of the following statements are **Correct** ?

- (a) Energy flow from producers to consumers is unidirectional
- (b) Energy pyramid can never be inverted
- (c) Transfer of energy follows the 1% law

Choose the **correct** answer from the options given below :

- (1) (a) and (b) only
- (2) (a) and (c) only
- (3) (b) and (c) only
- (4) (a), (b) and (c)

Answer (1)

179. Muscle contraction is initiated by a signal sent by the central nervous system by the release of _____ .
- (1) acetyl coenzyme A
 - (2) cyclic guanine monophosphate
 - (3) cyclic adenine monophosphate
 - (4) acetyl choline

Answer (4)

180. Which of the following enzymes synthesizes precursor mRNA?
- (1) RNA polymerase II
 - (2) RNA polymerase III
 - (3) DNA polymerase
 - (4) RNA polymerase I

Answer (1)

Sol. The **RNA** polymerase II transcribes precursor of **mRNA**, the heterogeneous nuclear RNA (hnRNA)

