

DATE: 21/06/2026

Test Booklet Code



80

SUSHRUT

Corporate Office: 3rd Floor, Incuspaze Campus-2, Plot No. 13,
Sector-18, Udyog Vihar, Gurugram, Haryana - 122015.

Answers & Solutions for

Time : 3 hrs. 15 min.

M.M. : 720

NEET (UG)-2026 (Re-Examination)

Important Instructions:

1. The test is of **3 hours 15 minutes** duration and the Test Booklet contains **180** multiple choice questions (Four options with a single correct answer) from **Physics, Chemistry & Biology (Botany and Zoology)**.
2. Each question carries **4 marks**. For each correct response, the candidate will get **4 marks**. For each incorrect response, **1 mark** will be deducted from the total scores. The maximum marks are **720**.
3. Use **Blue / Black Ball Point Pen only** for writing particulars on this page / marking responses on Answer Sheet.
4. Rough work is to be done in the space provided for this purpose in the Test Booklet only.
5. On completion of the test, the candidate **must handover the Answer Sheet (original & office copy) to the Invigilator** before leaving the Room / Hall. The candidates are allowed to take away this Test Booklet with them.
6. The **CODE** for this Booklet is **80**.
7. The candidates should ensure that the Answer Sheet is not folded. Do not make any stray marks on the Answer Sheet. Do not write your Roll No. anywhere else except in the specified space in the Test Booklet/Answer Sheet. Use of white fluid for correction is **NOT** permissible on the Answer Sheet.
8. Each candidate must show on-demand his/her Admit Card to the Invigilator.
9. No candidate, without special permission of the Centre Superintendent or Invigilator, would leave his/her seat.
10. Use of Electronic/Manual Calculator is prohibited.
11. The candidates are governed by all Rules and Regulations of the examination with regard to their conduct in the Examination Hall. All cases of unfair means will be dealt with as per Rules and Regulations of this examination.
12. No part of the **Test Booklet** and **Answer Sheet** shall be detached under any circumstances.
13. The candidates will write the Correct Test Booklet Code as given in the Test Booklet / Answer Sheet in the Attendance Sheet.

PHYSICS

1. An ideal gas is made of polyatomic molecules. Each of the molecules has three translational, three rotational and f number of vibrational modes. If the ratio of heat capacities C_P/C_V of the gas is $8/7$, then the value of f is:

- (1) 3 (2) 2
(3) 1 (4) 4

Answer (4)

Sol. The total internal energy for one mole of gas, U

$$= \left(\frac{3}{2}k_B T + \frac{3}{2}k_B T + f k_B T \right) N_A$$

$$= (3 + f)k_B T N_A = (3 + f)RT$$

$$\therefore C_V = \frac{dU}{dT} = (3 + f)R$$

$$C_P = C_V + R = (4 + f)R$$

$$\Rightarrow \frac{C_P}{C_V} = \frac{4 + f}{3 + f} = \frac{8}{7} \text{ (given)}$$

$$\Rightarrow f = 4$$

2. One main scale division of a Vernier calliper is equal to 1 mm and the number of divisions on the Vernier scale is 10. When both the jaws touch each other, the Vernier scale shifts to the left of zero of the main scale in such a way that 4th Vernier division coincides with a division of the main scale. If this Vernier calliper measures the length of the wire to be 1 cm, the actual length of the wire is :

- (1) 0.96 cm (2) 1.00 cm
(3) 1.04 cm (4) 0.60 cm

Answer (No option is correct)

Sol. \Rightarrow There is negative zero error

$$\Rightarrow \text{Zero error} = -(10 - 4) \times \text{L.C.} \dots (i)$$

From ... (i)

$$\text{Zero error} = -(10 - 4) \times 0.01 = -0.06 \text{ cm}$$

$$\Rightarrow \text{Zero correction} = - \text{Zero error}$$

$$= -(-0.06)$$

$$= 0.06 \text{ cm}$$

$$\Rightarrow \text{Correct reading} = R'$$

$$R' = R + \text{Zero correction}$$

$$= 1 + 0.06$$

$$= 1.06 \text{ cm}$$

\therefore No option is correct

5. An electromagnetic wave travelling in a lossless dielectric medium having a dielectric constant, $\epsilon_r = 9$, has the electric field, $E_x = E_0 \sin(kz - 2\pi \times 10^6 t)$ Vm^{-1} where E_0 is the amplitude and k is the wave vector. Among the following options, the **incorrect** choice is
- (1) The wavelength of the electromagnetic wave inside the medium is 300 m
 - (2) The magnetic field is given by the relation $B_y = \frac{B_0}{v} \sin(kz - 2\pi \times 10^6 t)$ where v is the speed of the electromagnetic wave inside the medium
 - (3) The direction of propagation of the electromagnetic wave is along $+z$
 - (4) The speed of the electromagnetic wave inside the medium is 10^8 ms^{-1}

Answer (1)

Sol.

$$\Rightarrow E_x = E_0 \sin(kz - 2\pi \times 10^6 t) = E_0 \sin(kz - \omega t)$$

\Rightarrow Direction of propagation of wave is along $+z$ axis.

\Rightarrow Speed of wave in medium

$$v_m = \frac{v_0}{\sqrt{\epsilon_r}} = \frac{c}{\sqrt{9}} = \frac{3 \times 10^8}{3}$$

$$v_m = 10^8 \text{ m/s}$$

\Rightarrow Wavelength in medium = λ_m

$$\lambda_m = \frac{v_m}{f_0} = \frac{10^8}{\frac{2\pi \times 10^6}{2\pi}} = 100 \text{ m} [\because f_0 = \text{constant}]$$

\therefore Wavelength of the electromagnetic wave inside the medium is 100 m.

Note: Among the options, in the expression $B_y = \frac{B_0}{v} \sin(kz - 2\pi \times 10^6 t)$, B_0 should be replaced by E_0 .

6. A frictionless circular wire of unit radius is fixed on the horizontal plane. Two-point particles of unit mass start moving simultaneously from point $A \left(\theta = \frac{\pi}{2} \right)$ with identical uniform angular speeds in opposite directions, and meet again at point $B \left(\theta = -\frac{\pi}{2} \right)$. During this time, which of the following figures schematically represent the magnitude of the total linear momentum P of the system, as a function of θ ?

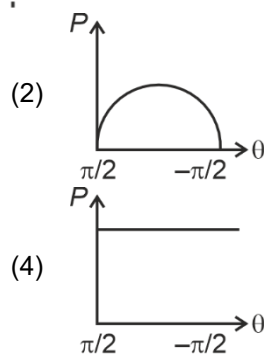
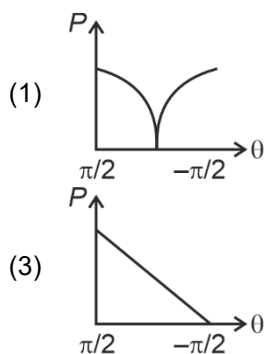
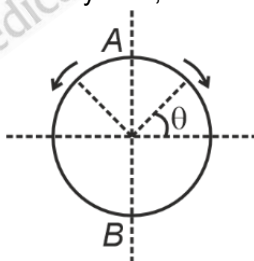

Answer (2)

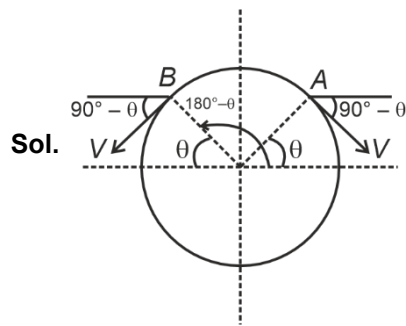

$$\vec{P}_{\text{net}} = -mv \sin \theta \hat{i} - mv \cos \theta \hat{j} + mv \sin \theta \hat{i} - mv \cos \theta \hat{j}$$

$$\vec{P}_{\text{net}} = -2mv \cos \theta \hat{j}$$

at $\theta = \frac{\pi}{2}$, $\vec{P}_{\text{net}} = 0$, at $\theta = -\frac{\pi}{2}$, $\vec{P}_{\text{net}} = 0$

So most appropriate graph is

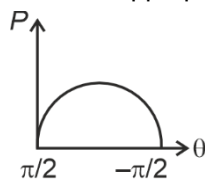

7. In Geiger-Marsden experiment, the number of scattered α -particles $N(\theta)$ is plotted as a function of scattering angle θ . Which of the following options represents the correct plot?

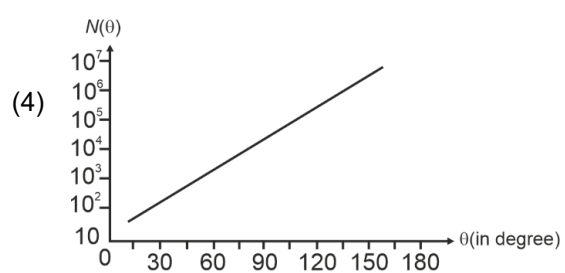
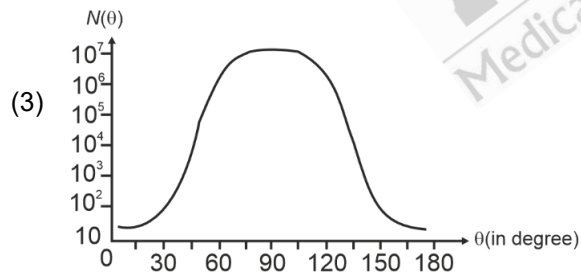
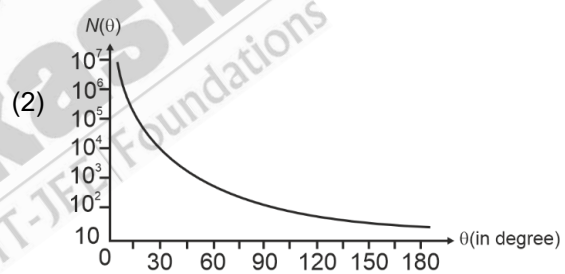
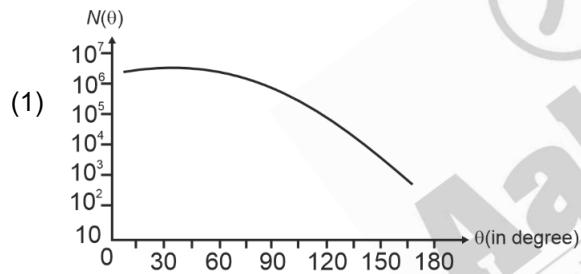

Answer (2)

Sol. Number of scattered α -particles at angles (α)

$$= K \times \frac{1}{\sin^4\left(\frac{\alpha}{2}\right)}$$

$$= N(\theta) = \frac{K}{\sin^4\left(\frac{\theta}{2}\right)}$$

Graph will be

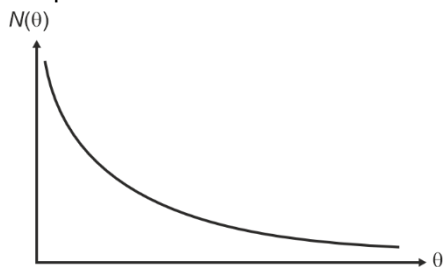

8. Consider three media P , Q and R with refractive indices 1, 1.25, and 1.5 respectively. The medium Q having a thickness of 5 cm is placed between extended media P and R as shown in the figure. An object O is placed at the centre of medium Q . If viewed from medium P near the normal direction, the apparent depth of O is h_1 . For similar observation from medium R , the apparent depth is h_2 . The value of $|h_1 - h_2|$, in cm, is:

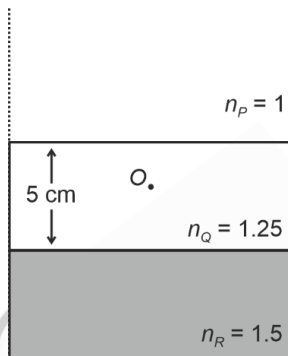

(1) 1

(2) 2

(3) 3

(4) 0

Answer (1)

Sol. (i) When object O is viewed from medium P ,

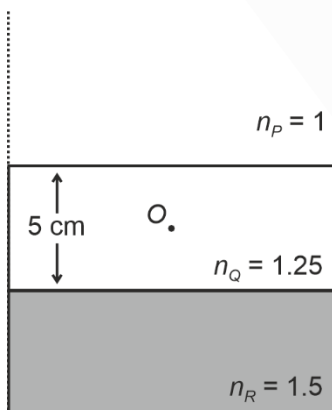

$$\text{Apparent depth } h_1 = \frac{h_{\text{real}}}{\mu} = \frac{2.5}{1.25} = 2 \text{ cm}$$

(ii) When object O is viewed from medium R ,

$$\text{Apparent depth } h_2 = {}_Q\mu_R \times 2.5$$

$$= 2.5 \times \frac{1.5}{1.25} = 3 \text{ cm}$$

$$\therefore |h_1 - h_2| = 1 \text{ cm}$$

9. Consider that σ_s , k_B , b represents Stefan-Boltzmann constant, Boltzmann constant and Wien's displacement law constant, respectively. The dimension of $\sigma_s k_B^{-1} b$ is

- (1) $[L^{-1}K^{-2}]$ (2) $[L^{-1}T^{-1}K^{-3}]$
 (3) $[L^{-1}T^{-1}K^{-4}]$ (4) $[L^{-1}T^{-1}K^{-2}]$

Answer (4)

Sol. $\sigma_s = MT^{-3}K^{-4}$

$$k_B = M^1 L^2 T^{-2} K^{-1}$$

$$b = M^0 L T^0 K$$

$$\sigma_s k_B^{-1} b = [MT^{-3}K^{-4}][M^{-1}L^{-2}T^2K][M^0LT^0K]$$

$$= T^{-1}K^{-2}L^{-1}$$

$$= L^{-1}T^{-1}K^{-2}$$

10. For sound waves, if the number of nodes for the 5th harmonic of an open-ended pipe is n and that for the 9th harmonic of the same pipe with one of its ends closed is m , the ratio $\frac{n}{m}$ is

- (1) $\frac{9}{5}$ (2) 1
 (3) $\frac{3}{5}$ (4) $\frac{5}{9}$

Answer (2)

Sol. For open organ pipe

→ Number of nodes are same as number of harmonics

$$\therefore n = 5$$

For closed organ pipe

→ There are only odd harmonics

For 1st harmonic → Number of node → 1

For 3rd harmonic → Number of node → 2

For 5th harmonic → Number of node → 3

For 7th harmonic → Number of node → 4

For 9th harmonic → Number of node → 5

$$\therefore m = 5$$

$$\rightarrow \frac{n}{m} = \frac{5}{5} = 1$$

11. Two infinitely long parallel conducting wires A and B carry currents I and $2I$, respectively, in the same direction. The wire A has uniform mass per unit length λ and lies on an insulated floor. The wire B is kept fixed at a height h above the floor. The minimum magnitude of h so that the wire A does not rise from the floor is:

[g is the acceleration due to gravity and μ_0 is the permeability of free space.]

- (1) $\frac{\mu_0 I^2}{\pi \lambda g}$ (2) $\frac{2\mu_0 I^2}{\pi \lambda g}$
 (3) $\frac{4\mu_0 I^2}{\pi \lambda g}$ (4) $\frac{\mu_0 I^2}{2\pi \lambda g}$

Answer (1)

Sol.

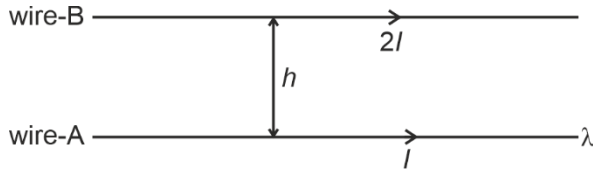

Force per unit length on wire A by wire B

$$F = \frac{\mu_0}{4\pi} \frac{2I \cdot 2I}{h} = \frac{\mu_0}{4\pi} \frac{4I^2}{h}$$

If $F_{net} \leq mg$, weight of wire A, then wire does not rise from the floor.

So, $F \leq mg$,

$$\frac{\mu_0}{4\pi} \frac{4I^2}{h} \leq \lambda g$$

$$\therefore h \geq \frac{\mu_0 I^2}{\pi \lambda g}$$

12. An ac voltage $V = 220 \sin(2 \times 10^3 t)$ Volt is applied to a series LCR circuit. Then the current amplitude in this circuit is:

(Given : $L = 10 \text{ mH}$, $C = 25 \text{ } \mu\text{F}$, $R = 100 \text{ } \Omega$)

- (1) 5.5 A (2) 11.0 A
(3) 22.0 A (4) 2.2 A

Answer (4)

Sol. Angular frequency of AC source, $\omega = 2 \times 10^3 \text{ rad/s}$

Inductive reactance, $X_L = \omega L = (2 \times 10^3) \times (10 \times 10^{-3}) = 20 \text{ } \Omega$

Capacitive reactance, $X_C = \frac{1}{\omega C} = \frac{1}{(2 \times 10^3) \times (25 \times 10^{-6})} = 20 \text{ } \Omega$

Impedance Z for circuit = R ($\because X_L = X_C$ and circuit is at resonance)

\therefore current amplitude, $i_0 = \frac{V_0}{Z} = \frac{V_0}{R} = \frac{220}{100} = 2.2 \text{ A}$

13. Consider a fixed uniformly charged insulating sphere with radius R and total charge $+Q$. A point charge $-q$ ($q < Q$) with mass m is released from rest at a distance of $3R$ from the centre of the charged sphere. When the point charge reaches the surface of the sphere, its speed is:

(ϵ_0 is the permittivity of vacuum, neglect gravitational forces).

- (1) $\sqrt{\frac{2Qq}{3\pi\epsilon_0 mR}}$ (2) $\sqrt{\frac{Qq}{3\pi\epsilon_0 mR}}$
(3) $\sqrt{\frac{Qq}{4\pi\epsilon_0 mR}}$ (4) $\sqrt{\frac{3Qq}{4\pi\epsilon_0 mR}}$

Answer (2)

Sol.

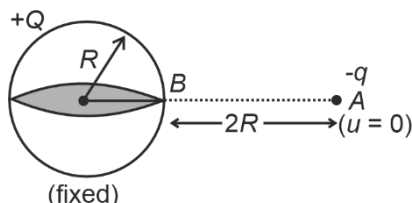

Sol. $V_e = \sqrt{2gR} = \sqrt{\frac{2GM}{R}}$

$V_e \propto \frac{1}{\sqrt{R}}$ [$\because M = \text{constant}$]

$\frac{V_{e2}}{V_{e1}} = \sqrt{\frac{R_1}{R_2}} = \sqrt{2}$

16. A unit positive point charge is taken slowly through an infinitesimally thin tube that is inside a charged dielectric sphere of radius R , having uniform positive charge density ρ , as shown in the figure. The initial and final positions of the charge are marked by A and B at distance $2R$ and $3R$ respectively, from the centre of the sphere. In this process, the magnitude of the total work done on the point charge is $\frac{\rho R^2}{n\epsilon_0}$. The value of n is :

(ϵ_0 is the permittivity of vacuum)

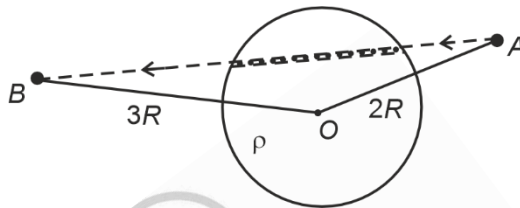

(1) 6

(2) 9

(3) 18

(4) 2

Answer (3)

Sol. Work done $W = q(V_B - V_A)$

$= q \left[\frac{KQ}{3R} - \frac{KQ}{2R} \right] = \frac{Kq}{R} \left[\frac{-Q}{6} \right]$

$|W| = \frac{KqQ}{6R} = \frac{1}{4\pi\epsilon_0} \times \frac{q}{R} \times \frac{1}{6} \times \rho \times \frac{4}{3}\pi R^3$

$|W| = \frac{\rho R^2}{18\epsilon_0}$ [$\because q = 1$]

$\therefore n = 18$

17. One mole of an ideal monatomic gas undergoes a cyclic process as shown in the figure. The total heat supplied to the gas is:

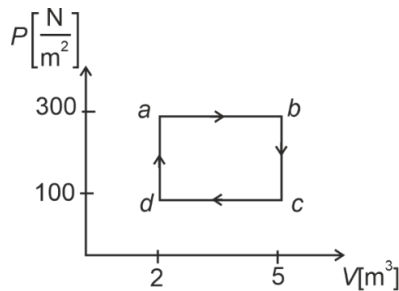

(1) 500 J

(2) 600 J

(3) 800 J

(4) 400 J

Answer (2)

Sol. For any cyclic process, change in internal energy $\Delta U = 0$

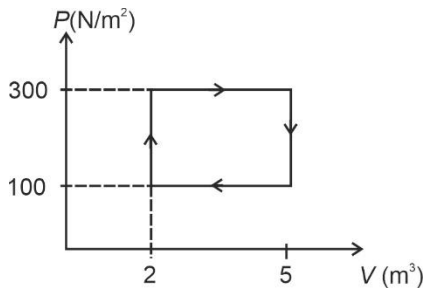

Here, total heat exchange

$$\begin{aligned} \Delta Q &= W + \Delta U \\ &= W \\ &= (300 - 100) (5 - 2) \\ &= 200 \times 3 \\ &= 600 \text{ J} \end{aligned}$$

18. The following table presents the part of the electromagnetic spectrum and their corresponding major applications.

	Part of the electromagnetic spectrum		Applications
P.	Microwave	I.	For purifying the water
Q.	UV rays	II.	For warming the food
R.	Gamma rays	III.	For AM and FM communication systems
S.	Radio wave	IV.	For treating the Cancer cells

The **correct** option is:

- (1) P-I, Q-IV, R-II, S-III
 (2) P-II, Q-I, R-IV, S-III
 (3) P-II, Q-IV, R-III, S-I
 (4) P-I, Q-II, R-III, S-IV

Answer (2)

Sol.

Part of the electromagnetic spectrum		Applications
Microwave	–	For warming of food
UV rays	–	For purifying the water
Gamma rays	–	For treating the cancer cells
Radio wave	–	For AM and FM communication systems

19. A car travels on a circular racetrack of radius 50 m, which is banked at an angle θ . If the car travels at a speed 10 ms^{-1} , then the wear and tear on its tyres is minimum. Taking the acceleration due to gravity to be 10 ms^{-2} , the value of θ is:

- (1) $\tan^{-1}\left(\frac{2}{5}\right)$
 (2) $\tan^{-1}(\sqrt{3}/2)$
 (3) $\tan^{-1}(2\sqrt{3})$
 (4) $\tan^{-1}\left(\frac{1}{5}\right)$

Answer (4)

Sol. $\tan\theta = \frac{v^2}{rg} = \frac{10 \times 10}{50 \times 10} = \frac{1}{5}$

$$\theta = \tan^{-1}\left(\frac{1}{5}\right)$$

20. Consider a particle moving along a straight line, whose position as a function of time is given by $s(t) = \alpha t^2 - \beta t + \gamma$, where $\alpha = 1 \text{ ms}^{-2}$, $\beta = 6 \text{ ms}^{-1}$ and $\gamma = 5 \text{ m}$. The average speed of the particle, in ms^{-1} from $t = 0$ to $t = 6 \text{ s}$ is:

- (1) 6 (2) 3
(3) 0 (4) 12

Answer (2)

Sol. Position (s)

$$S = \alpha t^2 - \beta t + \gamma$$

$$S = t^2 - 6t + 5 \quad \dots(i)$$

Velocity (v)

$$v = \frac{ds}{dt} = 2t - 6 \quad \dots(ii)$$

$$\text{When } v = 0 = 2t - 6$$

$$t = 3 \text{ s}$$

From (ii), graph between (v/t)

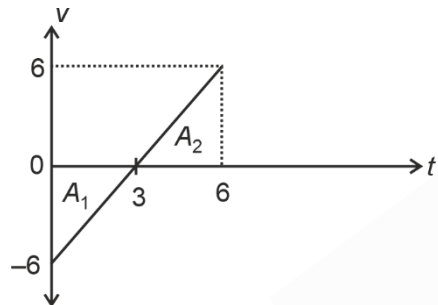

For distance

$$d = (+A_1) + A_2$$

$$d = \frac{1}{2} \times 3 \times 6 + \frac{1}{2} \times 3 \times 6$$

$$d = 3 \times 6 = 18$$

$$\text{Average speed } (v_{\text{avg}}) = \frac{\text{Distance}}{\text{Time}} = \frac{d}{\Delta t} = \frac{18}{6} = 3 \text{ ms}^{-1}$$

21. A point charge Q is placed inside a cavity within a solid isolated conducting sphere. Consider points A , B and C as shown in the figure, where the magnitudes of the electric fields are E_A , E_B , E_C , respectively. The points B and C are at the same distance from the center of the solid sphere. The correct option is :

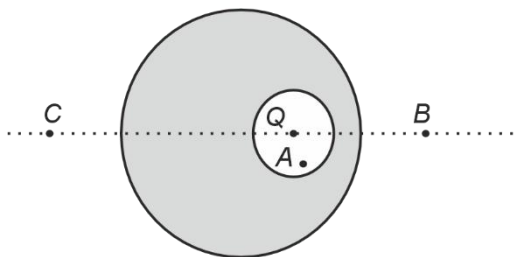

- (1) $E_A \neq 0, E_B = E_C$ (2) $E_A = 0, E_B > E_C$
(3) $E_A \neq 0, E_B < E_C$ (4) $E_A = 0, E_B = E_C$

Answer (1)

Sol. Due to charge Q present inside cavity, $E_A \neq 0$

Charge distribution will be uniform on the outer surface of conducting sphere,

Since B and C are at same distance from centre of sphere,

$\therefore E_B = E_C$ (Due to electrostatic shielding)

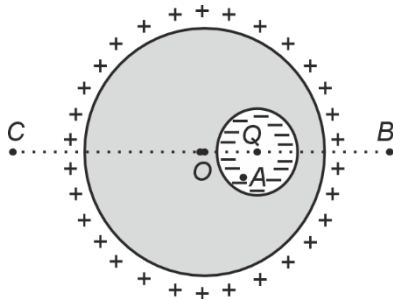

22. In the measurement of viscosity of liquids using terminal velocity experiment, spherical balls of same radius but having different densities are used. The variation of the terminal velocity (v) with the ratio of density of spherical ball (σ) to density of the liquid (ρ), is best represented by:

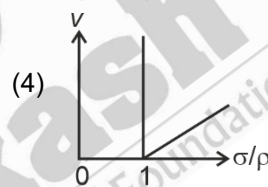
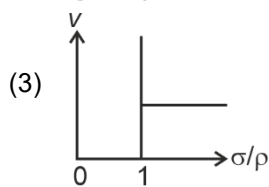
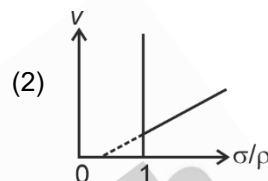
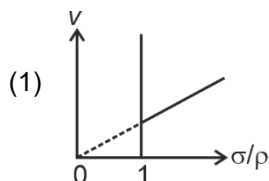

Answer (4)

Sol. Terminal velocity $V_T = \frac{2r^2}{9h}(\sigma - \rho)$

$$V_T = \frac{2r^2}{9h} \rho \left(\frac{\sigma}{\rho} - 1 \right) \quad \dots(I)$$

$$y = mx + c \quad \dots(II)$$

Equation number (I) is like equation number which is straight line with negative intercept.

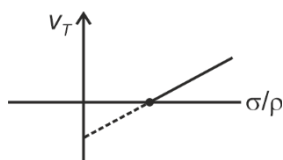

23. A ray of light with wavelength λ is incident on three different photoelectric cells namely 1, 2 and 3. The threshold wavelength of these photoelectric cells are λ_1 , λ_2 , and λ_3 , respectively and the magnitude of stopping potentials of these cells are V_1 , V_2 and V_3 , respectively. The relation between λ and threshold wavelengths are $\lambda_1 < \lambda$, $\lambda_2 > \lambda$ and $\lambda_3 \gg \lambda$. The correct option is:

(1) $V_1 = 0, V_2 > V_3$

(2) $V_1 > V_2, V_3 = 0$

(3) $V_1 < V_2, V_3 = 0$

(4) $V_1 = 0, V_2 < V_3$

Answer (4)

Sol. For ejection of electron energy of incident photon should be greater than work function

$$\phi = \frac{hc}{\lambda}$$

$$\phi_1 = \frac{hc}{\lambda_1}$$

$$\lambda_1 < \lambda$$

$$\phi_1 > \phi$$

No electron will eject

$$V_1 = 0$$

By Einstein photoelectric equation

$$\phi = \phi_0 + eV$$

$$\lambda_2 > \lambda$$

$$\lambda_3 \gg \lambda$$

$$\phi > \phi_2$$

$$\phi \gg \phi_3$$

$$\text{So, } V_3 > V_2$$

24. A current I_0 flows through a metallic circular loop of radius r as shown in the figure. Resistance of the segment ABC is half that of ADC. Magnitude of magnetic field at the centre O of the loop is :

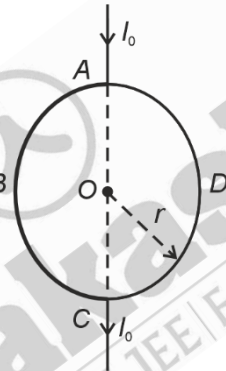

(1) $\frac{\mu_0 I_0}{4r}$

(2) $\frac{\mu_0 I_0}{2r}$

(3) $\frac{\mu_0 I_0}{2\pi r}$

(4) $\frac{\mu_0 I_0}{12r}$

Answer (4)

Sol.

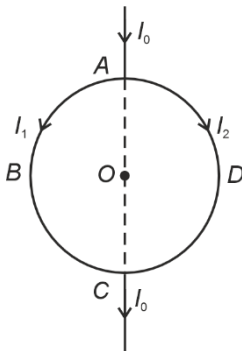

$$I_1 + I_2 = I_0$$

$$2I_2 + I_2 = I_0$$

$$I_1 R_{ABC} = I_2 R_{ADC}$$

$$I_1 + I_2 = I_0$$

$$I_1 \frac{R}{2} = I_2 R$$

$$\frac{I_1}{2} = I_2$$

$$I_2 = \frac{I_0}{3}$$

$$I_1 = \frac{2I_0}{3}$$

$$\begin{aligned}\vec{B}_0 &= \vec{B}_1 + \vec{B}_2 \\ &= \frac{\mu_0 I_1(\bullet)}{4r} + \frac{\mu_0 I_2(\times)}{4r} \\ &= \frac{\mu_0 2I_0}{4r \times 3} - \frac{\mu_0 I_0}{4r \times 3} = \frac{\mu_0 I_0}{12r}\end{aligned}$$

25. A particle of mass M moves along a horizontal x axis from $x = 0$ to $x = L$. The coefficient of kinetic friction varies as a function of x as $\mu_k(x) = \mu_0 - \alpha x$, where μ_0, α are constants of appropriate dimensions, so that $\mu_k(L) = 0$. The total work done by the frictional force during the motion is $n\mu_0 MgL$, where g is the acceleration due to gravity. The value of n is:

- (1) 1 (2) $\frac{1}{3}$
(3) $\frac{1}{2}$ (4) 3

Answer (3)

Sol. Given $\mu_k(x) = \mu_0 - \alpha x$ and $\mu_k(L) = 0 = \mu_0 - \alpha L \Rightarrow \mu_0 = \alpha L$

Magnitude of work done by frictional force, $W_f = \int dW_f$

where $dW_f = f_k dx = \mu_k N dx = \mu_k Mg dx = (\mu_0 - \alpha x) Mg dx$

$$\therefore W_f = \int_0^L \mu_0 Mg dx - \int_0^L \alpha Mg x dx = \mu_0 Mg [x]_0^L - \alpha Mg \left[\frac{x^2}{2} \right]_0^L$$

$$\Rightarrow n\mu_0 MgL = \mu_0 MgL - \left(\frac{\mu_0}{L} \right) Mg \left(\frac{L^2}{2} \right) = \frac{\mu_0 MgL}{2}$$

$$\Rightarrow n = \frac{1}{2}$$

26. In a solar system, the time-period of revolution of a planet tracing a circular orbit of radius R is proportional to:

- (1) $R^{3/2}$ (2) R^2
(3) R^3 (4) $R^{1/2}$

Answer (1)

Sol. In planetary motion

$$T^2 \propto R^3$$

$$T \propto R^{3/2}$$

27. A solid sphere A of radius R and mass M is attached at a point to a smaller solid sphere B of radius $r < R$ and mass $m < M$. Assume that the line joining their centres lies along the horizontal. The moment of inertia of the system calculated about a vertical axis passing through the centre of A is I_A and that calculated about a vertical axis passing through the centre of B is I_B . The difference $I_A - I_B$ is:

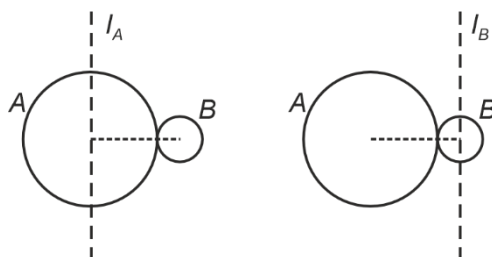

- (1) $(m - M)(R + r)^2$ (2) $(m - M)(R - r)^2$
(3) 0 (4) $(M - m)(R + r)^2$

Answer (1)

Sol. Using $I_C = \frac{2}{5}mR^2$ and Parallel axis theorem, moment of inertia of system

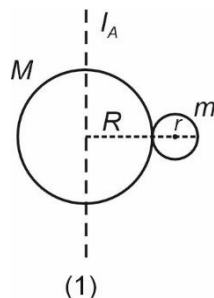

$$I_A = \frac{2}{5}MR^2 + \frac{2}{5}mr^2 + m(R+r)^2 \quad \dots(1)$$

Similarly,

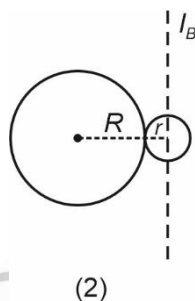

$$I_B = \frac{2}{5}MR^2 + M(R+r)^2 + \frac{2}{5}mr^2 \quad \dots(2)$$

Now, subtracting (1) and (2)

$$I_A - I_B = (m - M)(R+r)^2$$

28. The lens combination as shown in the figure, consists of two lenses, L_1 and L_2 , of the focal lengths +10 cm and -10 cm, respectively. The position of the image formed is:

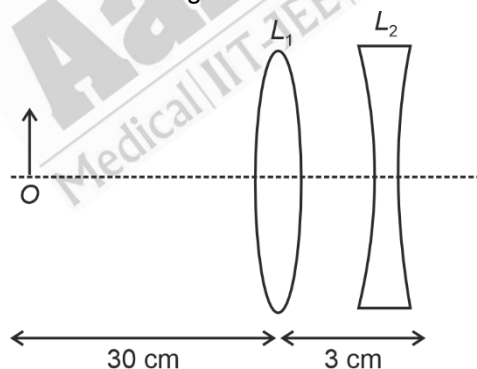

- (1) 60 cm to the left of the concave lens (2) 30 cm to the right of the concave lens
(3) 60 cm to the right of the concave lens (4) 20 cm to the left of the concave lens

Answer (1)

Sol. For convex lens L_1 : $u = -30$ cm and $f = +10$ cm

$$\text{Using } \frac{1}{v} - \frac{1}{u} = \frac{1}{f} \Rightarrow \frac{1}{v} + \frac{1}{30} = \frac{1}{10} \Rightarrow \frac{1}{v} = \frac{1}{10} - \frac{1}{30} = \frac{2}{30}$$

$$\therefore v = +\frac{30}{2} = +15 \text{ cm}$$

For concave lens L_2 : $u' = +12$ cm and $f' = -10$ cm

$$\text{Using } \frac{1}{v'} - \frac{1}{u'} = \frac{1}{f'} \Rightarrow \frac{1}{v'} - \frac{1}{12} = \frac{-1}{10} \Rightarrow \frac{1}{v'} = \frac{1}{12} - \frac{1}{10} = \frac{-1}{60}$$

$$\therefore v' = -60 \text{ cm}$$

⇒ Final image formed at 60 cm to the left of concave lens.

29. An ideal Zener diode with breakdown voltage of -3 V is reverse biased with a negative input voltage $V_i = -5 \text{ V}$. The magnitude of voltage difference between point B and A is:

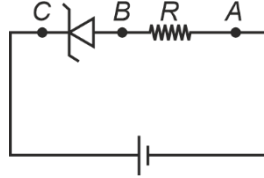

(1) 2 V

(3) 0 V

(2) 1 V

(4) 3 V

Answer (1)

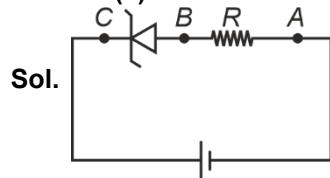

$$|V_{\text{input}}| (5 \text{ V}) > |V_{\text{zener}}| (3 \text{ V})$$

$$V_{\text{zener}} = 3 \text{ V}$$

$$V_{\text{Total}} = 5 \text{ V}$$

$$\therefore |V_{BA}| = (5 - 3) = 2 \text{ V}$$

30. Three identical capacitors, P , Q and S , each of the capacitance C , are connected to a battery of voltage V , as shown in the figure. If the energy stored in the capacitor P and total energy stored in the system are U_P and U_T , respectively, then the ratio $\frac{U_P}{U_T}$ is:

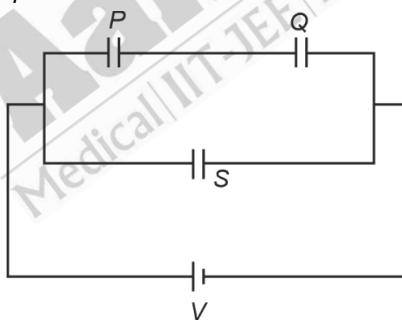

(1) $1/3$

(3) $1/6$

(2) $1/2$

(4) $2/3$

Answer (3)

Sol. $C_P = C_Q = C_S = C$

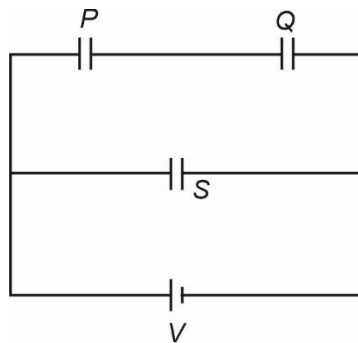

$$U_P = \frac{1}{2}C\left(\frac{V}{2}\right)^2 = \frac{1}{2} \frac{CV^2}{4} = \frac{CV^2}{8}$$

$$U_T = U_P + U_Q + U_S = \frac{1}{2}C\left(\frac{V}{2}\right)^2 + \frac{1}{2}C\left(\frac{V}{2}\right)^2 + \frac{1}{2}CV^2$$

$$= \frac{CV^2}{8} + \frac{CV^2}{8} + \frac{1}{2}CV^2 = \frac{6}{8}CV^2 = \frac{3}{4}CV^2$$

$$\frac{U_P}{U_T} = \frac{CV^2}{\frac{8 \times 3CV^2}{4}} = \frac{1}{6}$$

31. A conducting loop of finite resistance lies on the $x - y$ plane. There is a constant magnetic field in the z direction. The area of the loop varies with time t , as $A = A_0(1 + \sin t)$ in appropriate units. The figure that correctly indicates the qualitative behaviour of the power P dissipated in the loop as a function of time is:

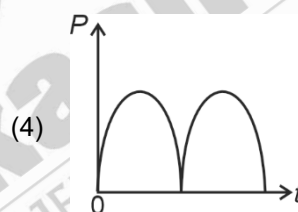
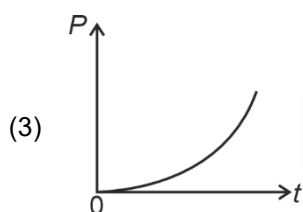
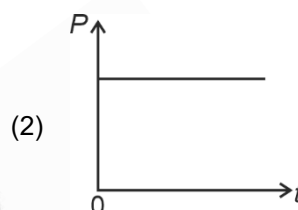
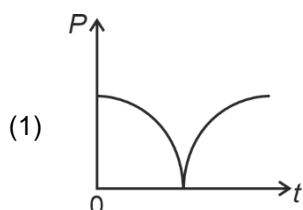

Answer (1)

Sol. $A = A_0(1 + \sin t)$

$$\phi = BA = BA_0(1 + \sin t)$$

$$\varepsilon = -\frac{d\phi}{dt} = -BA_0 \cos t$$

$$I_{\text{induced}} = \frac{\varepsilon_{\text{ind}}}{R} = -\frac{BA_0}{R} \cos t$$

$$\text{Power} = P = I^2 R = \frac{B^2 A_0^2 \cos^2 t}{R}$$

$$P \propto \cos^2 t$$

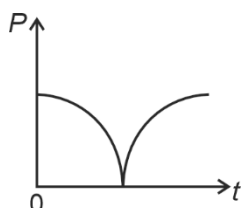

32. Consider two circuits, (A) and (B), each having two resistors. One of them has a positive temperature coefficient of resistance, $+\alpha$, while the other one has a negative temperature of coefficient, $-\alpha$, as shown in the figure. The current through these circuits are denoted by I_A and I_B . At initial temperature, the resistance of the two resistors is R_0 . As the temperature is increased, the correct option that describes the variation of current in these circuits is:

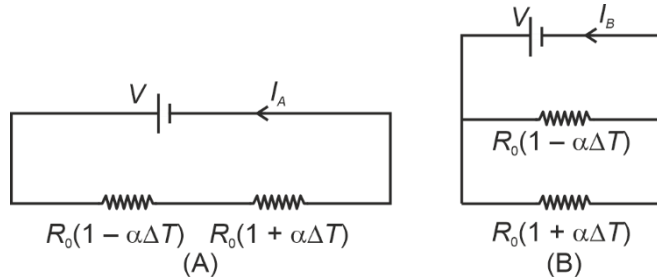

- (1) I_A decreases while I_B increases
 (2) I_A increases while I_B decreases
 (3) Both I_A and I_B remain constant
 (4) I_A remains constant while I_B increases

Answer (4)

Sol. Figure A

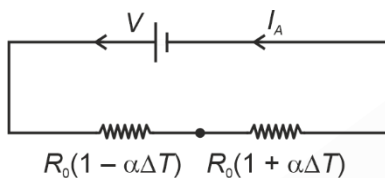

$$R_{eq} = R_0[1 - \alpha\Delta T] + R_0[1 + \alpha\Delta T]$$

$$= 2R_0 = \text{constant}$$

$$\therefore I_A = \frac{V}{2R_0} \rightarrow \text{constant}$$

Figure B

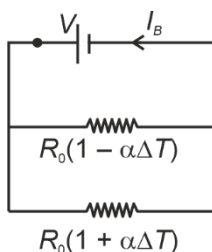

$$R_{eq} = \frac{R_0(1 + \alpha\Delta T) R_0(1 - \alpha\Delta T)}{R_0(1 + \alpha\Delta T) + R_0(1 - \alpha\Delta T)}$$

$$R_{eq} = \frac{R_0(1 - \alpha^2(\Delta T)^2)}{2R_0}$$

R_{eq} will decrease with rise in temperature

$$\therefore I_B = \frac{V_0}{R_{eq}} \text{ increases with rise in temperature}$$

33. Bob B of mass m at rest is hanging vertically from the ceiling via a massless string of length 10 m, as shown in the figure. Point mass A of mass m travelling horizontally with speed 10 ms^{-1} hits bob B elastically. The bob B rises h meter after the collision. Taking the acceleration due to gravity $g = 10 \text{ ms}^{-2}$ and neglecting the size of the bob, the value of h is:

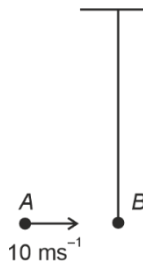

- (1) 7 (2) 5
(3) 2.5 (4) 8

Answer (2)

- Sol.** • To reach the horizontal position, velocity of bob should be $= 10\sqrt{2} \text{ m/s}$
• Velocity of bob and point mass will be interchanged after elastic collision

By conservation of energy

$$mgh = \frac{1}{2}mv^2$$

$$h = \frac{v^2}{2g}$$

$$h = \frac{(10\sqrt{2})^2}{2 \times 10}$$

$$h = 5 \text{ m}$$

34. A cylindrical cork of uniform density floats in a liquid of density ρ_1 . If the cork is depressed slightly and released, it oscillates harmonically with time period T . If the same cork floats in another liquid of density ρ_2 , then the similar oscillation has time period $2T$. The value of ρ_2 / ρ_1 is:

- (1) 2 (2) 1/2
(3) 1/4 (4) 4

Answer (3)

- Sol.** Time period of a cylinder oscillating inside the liquid

$$T = 2\pi \sqrt{\frac{\rho_s l}{\rho_l g}}$$

$$\frac{T_1}{T_2} = \sqrt{\frac{\rho_2}{\rho_1}} \quad [\because \rho_s \rightarrow \text{constant}]$$

$$\frac{T}{2T} = \sqrt{\frac{\rho_2}{\rho_1}}$$

$$\frac{\rho_2}{\rho_1} = \frac{1}{4}$$

35. The mean free path of molecules in an ideal gas A is half that of another ideal gas B . The diameter of the spherical molecules of gas A is twice the diameter of the molecules of B . If number densities of the gases A and B are n_A and n_B , respectively, the correct option is:

- (1) $n_A = 2n_B$ (2) $n_A = \frac{1}{4}n_B$
 (3) $n_A = \frac{1}{2}n_B$ (4) $n_A = n_B$

Answer (3)

Sol. $\lambda_A = \frac{1}{2}\lambda_B$

$$\lambda = \frac{1}{\sqrt{2}\pi d^2 n}$$

$$d_A = 2d_B$$

$$\lambda_A = \frac{1}{\sqrt{2}\pi d_A^2 n_A}$$

$$\lambda_B = \frac{1}{\sqrt{2}\pi d_B^2 n_B}$$

$$\frac{\lambda_A}{\lambda_B} = \frac{1}{2} = \frac{d_B^2 n_B}{d_A^2 n_A}$$

$$\frac{n_A}{n_B} = \frac{2 \cdot d_B^2}{d_A^2}$$

$$\frac{n_A}{n_B} = \frac{2 \cdot d_B^2}{4d_B^2} = \frac{1}{2}$$

36. Consider the following nuclear reaction

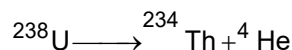

Take masses of ${}^{238}\text{U}$, ${}^{234}\text{Th}$ and ${}^4\text{He}$ as 238.050 u, 234.043 u and 4.003 u, respectively. The Q value for the reaction, in keV, is:

[Given: 1 u = 931.5 MeV c^{-2}]

- (1) 3730 (2) 3736
 (3) 3740 (4) 3726

Answer (4)

Sol. Q -value for the nuclear reaction is given by, $Q = \Delta mc^2$



$$\Rightarrow \Delta m = 238.050 - (234.043 + 4.003) = 0.004 \text{ u}$$

$$\therefore Q = 0.004 \times 931.5 \text{ MeV} = 3.726 \text{ MeV} = 3726 \text{ keV}$$

37. Consider a long solenoid of length l and radius r . If n is the number of turns per unit length and μ_0 is the permeability of free space, the inductance of the solenoid is :

- (1) $\mu_0 n^2 r^2 l$ (2) $(\mu_0/2\pi)n^2 r^2 l$
 (3) $2\mu_0 \pi n^2 r^2 l$ (4) $\mu_0 \pi n^2 r^2 l$

Answer (4)

Sol. Self inductance of solenoid

$$L = \frac{N\phi}{i}$$

$$L = \frac{NBA}{i}$$

$$L = \frac{N\mu_0 niA}{i} \left[n = \frac{N}{l} \right]$$

$$L = N\mu_0 nA$$

$$L = \left(\frac{N}{l} \right) \mu_0 nAl$$

$$L = \mu_0 n^2 Al$$

$$L = \mu_0 n^2 \pi r^2 l \left[\because A = \pi r^2 \right]$$

38. Which of the following measurements require 'index correction'?
- (1) Measurement of gravitational acceleration using simple pendulum
 - (2) Measurement of focal length of lenses using optical bench
 - (3) Measurement of speed of sound using resonance tube
 - (4) Measurement of resistance of a wire using meter bridge

Answer (2)

Sol. Index correction is an adjustment which need to perform in the experiments related to optical bench while measuring the focal length of lenses using optical bench.

39. The temperature of a metallic sphere of radius R is increased by a small amount ΔT . If the linear coefficient of thermal expansion of the metal is α , the approximate increase in the volume of the sphere is:
- (1) $3\pi R^3 \alpha \Delta T$
 - (2) $4\pi R^3 \alpha \Delta T$
 - (3) $6\pi R^3 \alpha \Delta T$
 - (4) $2\pi R^3 \alpha \Delta T$

Answer (2)

Sol. For the metallic sphere, $\frac{\Delta R}{R} = \alpha \Delta T$

Volume of the sphere, $V = \frac{4}{3} \pi R^3$

$$\therefore \frac{\Delta V}{V} = 3 \frac{\Delta R}{R}$$

$$\text{Increase in volume} = \Delta V = 3 \left(\frac{\Delta R}{R} \right) \left(\frac{4}{3} \pi R^3 \right) = 4\pi R^3 \alpha \Delta T$$

40. A photon and an electron, each of 20 eV energy, move in free space. The ratio of linear momentum of electron p_e to that of photon p_{ph} , $\frac{p_e}{p_{ph}}$ is:

[Take speed of light = $3 \times 10^8 \text{ ms}^{-1}$, charge of electron = $-1.6 \times 10^{-19} \text{ C}$ and mass of electron = $9 \times 10^{-31} \text{ kg}$]

- (1) $\frac{1}{250}$
- (2) 225
- (3) 275
- (4) $\frac{2}{450}$

Answer (2)

Sol. $E_e = E_{ph} = 20 \text{ eV}$

$$\Rightarrow P_e = \sqrt{2m_e E_e}, P_{ph} = \frac{E_{ph}}{c}$$

$$\Rightarrow \frac{P_e}{P_{ph}} = \frac{\sqrt{2m_e E_e}}{E_{ph}} c = \sqrt{\frac{2m_e}{E_{ph}}} c$$

$$\frac{P_e}{P_{ph}} = \sqrt{\frac{2 \times 9 \times 10^{-31}}{20 \times 1.6 \times 10^{-19}}} \times 3 \times 10^8$$

$$= \frac{3}{4} \times 10^{-6} \times 3 \times 10^8 = \frac{900}{4} = 225$$

41. Consider that an electron is revolving in an excited state of Hydrogen atom with velocity $\sqrt{25.6} \times 10^5 \text{ ms}^{-1}$. The radius of the orbit is $x \times 10^{-9} \text{ m}$. The value of x is:

[Take the mass of electron to be $9 \times 10^{-31} \text{ kg}$, charge of electron = $-1.6 \times 10^{-19} \text{ C}$ and $\frac{1}{4\pi\epsilon_0} = 9 \times 10^9 \text{ Nm}^2\text{C}^{-2}$]

- (1) 3 (2) 2
(3) 1 (4) 4

Answer (3)

Sol. $F_c = \frac{mv^2}{r}$

$$\Rightarrow \frac{kq_1q_2}{r^2} = \frac{mv^2}{r}$$

$$\Rightarrow \frac{ke^2}{r} = mv^2 \Rightarrow r = \frac{ke^2}{mv^2} = \frac{9 \times 10^9 \times (1.6 \times 10^{-19})^2}{9 \times 10^{-31} \times 25.6 \times 10^{10}}$$

$$\Rightarrow r = \frac{2.56 \times 10^9 \times 10^{-38}}{25.6 \times 10^{-21}}$$

$$r = 1 \times 10^{-9} \text{ m}$$

$$\therefore x = 1$$

42. Two identical inductors are connected in two different configurations P and Q , where a time varying current $I(t)$ is flowing, as shown in the figure. The induced emf between points a and b for configuration P is E_P and that for configuration Q is E_Q . The ratio E_P/E_Q is:

[Neglect the effect of mutual inductance.]

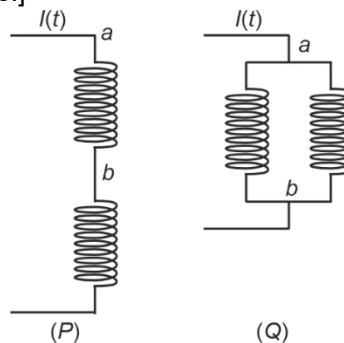

- (1) $\frac{1}{2}$ (2) 1
(3) 2 (4) $\frac{1}{4}$

Answer (3)

44. Water flows in a streamline motion through a horizontal pipe of circular cross-section as shown in the figure. The pressure difference of water between P and Q is 15 Nm^{-2} . The area of cross-section at P and Q are 40 cm^2 and 20 cm^2 , respectively. The rate of flow of water through the pipe, in cm^3s^{-1} , is:
[Take density of water = 1000 kg m^{-3}]

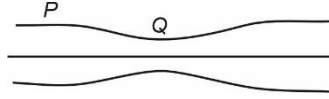

- (1) 200 (2) 300
(3) 400 (4) 100

Answer (3)

Sol. $A_P V_P = A_Q V_Q$

$$40V_P = 20V_Q, \quad V_Q = 2V_P$$

Using Bernoulli's equation:

$$P_P - P_Q = \frac{1}{2} \rho (V_Q^2 - V_P^2)$$

$$15 = \frac{1}{2} \times 10^3 (4V_P^2 - V_P^2)$$

$$V_P = \sqrt{\frac{15}{1500}} = 0.1 \text{ m/s}$$

$$V_Q = 0.2 \text{ m/s}$$

$$\text{Rate} = A_P V_P = 40 \times 10^{-4} \times 10^{-1} \text{ m}^3/\text{s}$$

$$= 4 \times 10^{-4} \text{ m}^3/\text{s}$$

$$= 4 \times 10^{-4} \times 10^6 \text{ cm}^3/\text{s}$$

$$= 400 \text{ cm}^3/\text{s}$$

45. A thin horizontal disc is rotating about a vertical axis passing through its fixed centre O . Its angular momentum is L_A and L_B computed about points A and B , respectively, with $OB = 2 \times OA$. The value of $\frac{L_A}{L_B}$ is:

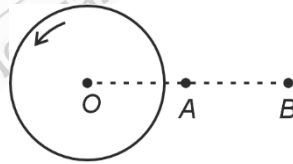

- (1) $\frac{1}{2}$ (2) 1
(3) 2 (4) $\frac{1}{4}$

Answer (2)

Sol. $\vec{L} = \vec{r} \times \vec{P} + I_{\text{cm}} \vec{\omega}$

$$\vec{P} = 0 \text{ for both axis}$$

$$\text{So } \vec{L}_A = \vec{L}_B = I_{\text{cm}} \vec{\omega}$$

$$\frac{\vec{L}_A}{\vec{L}_B} = 1$$